



SCM5B34

Linearized 2- or 3-Wire RTD Input Modules

Description

Each SCM5B34 RTD input module provides a single channel of RTD input which is filtered, isolated, amplified, linearized, and converted to a high-level analog voltage output (Figure 1). This voltage output is logic switch controlled, which allows these modules to share a common analog bus without the requirement of external multiplexers.

The SCM5B modules are designed with a completely isolated computer side circuit which can be floated to $\pm 50V$ from Power Common, pin 16. This complete isolation means that no connection is required between I/O Common and Power Common for proper operation of the output switch. If desired, the output switch can be turned on continuously by simply connecting pin 22, the Read-Enable pin, to I/O Common, pin 19.

RTD excitation is provided from the module by two matched current sources. When using a three-wire RTD, this method allows an equal current to flow in each RTD lead, which cancels the effects of lead resistances. The excitation currents are very small (0.25mA for 100 Ω Pt and 120 Ω Ni, and 1.0mA for 10 Ω Cu) which minimizes self-heating of the RTD.

Signal filtering is accomplished with a six-pole filter which provides 95dB of normal-mode rejection at 60Hz and 90dB at 50Hz. Two poles of this filter are on the field side of the isolation barrier, and the other four are on the computer side. After the initial field-side filtering, the input signal is chopped by a proprietary chopper circuit. Isolation is provided by transformer coupling, again using a proprietary technique to suppress transmission of common mode spikes or surges. The module is powered from +5VDC, $\pm 5\%$.

A special input circuit on the SCM5B34 modules provides protection against accidental connection of power-line voltages up to 240VAC.

Features

- Interfaces to 100 Ω Platinum, 10 Ω Copper, or 120 Ω Nickel RTDs
- Linearizes RTD Signal
- High-Level Voltage Outputs
- 1500Vrms Transformer Isolation
- ANSI/IEEE C37.90.1 Transient Protection
- Input Protected to 240VAC Continuous
- 160dB CMR
- 95dB NMR at 60Hz, 90dB at 50Hz
- CSA C/US Certified
- CE and ATEX Compliant
- Mix and Match SCM5B Types on Backpanel

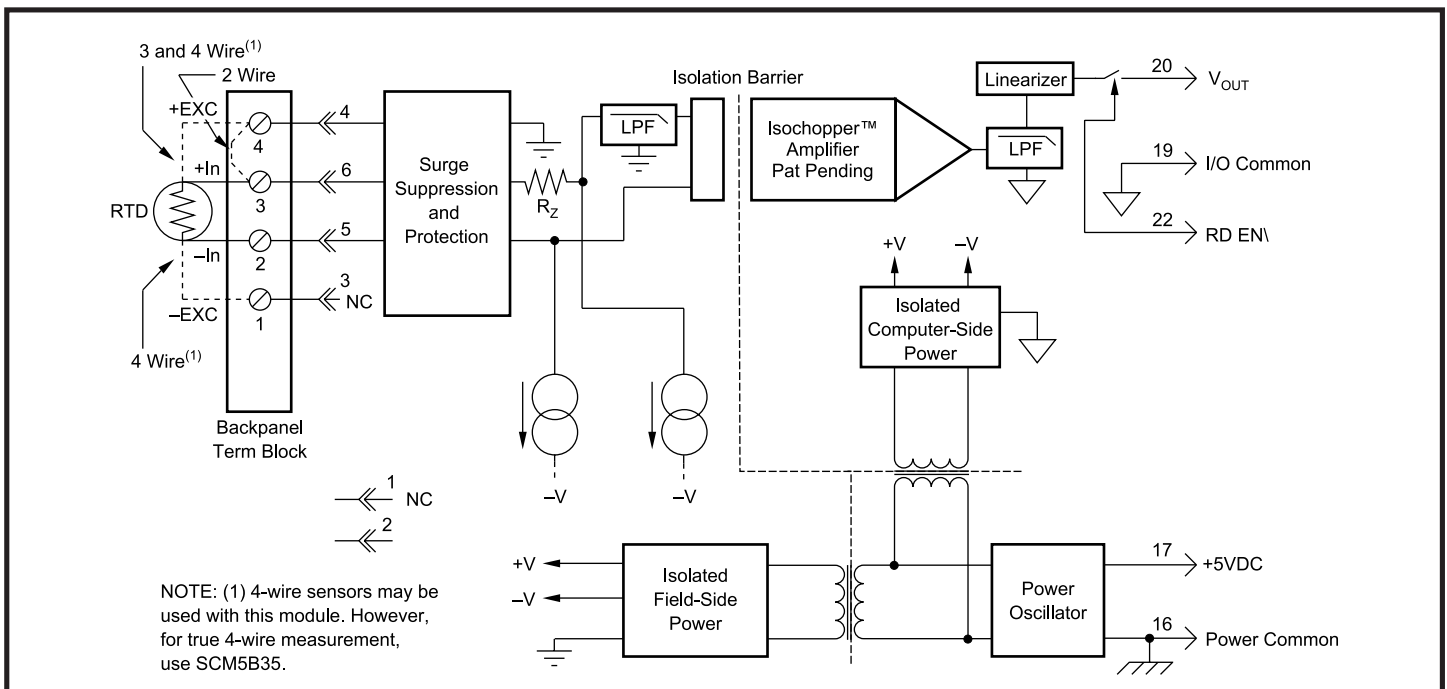

Figure 1: SCM5B34 Block Diagram

Specifications Typical* at $T_A = +25^\circ\text{C}$ and +5VDC power

Module	SCM5B34
Input Range Limits	-200°C to +850°C (100Ω Pt) -80°C to +320°C (120Ω Ni) -100°C to +260°C (10Ω Cu)
Input Resistance	
Normal	50MΩ
Power Off	40kΩ
Overload	40kΩ
Input Protection	
Continuous	240Vrms max
Transient	ANSI/IEEE C37.90.1
Sensor Excitation Current	
100Ω Pt, 120Ω Ni	0.25mA
10Ω Cu	1.0mA
Lead Resistance Effect	
100Ω Pt, 120Ω Ni	$\pm 0.02^\circ\text{C}/\Omega^{(1)}$
10Ω Cu	$\pm 0.2^\circ\text{C}/\Omega^{(1)}$
CMV, Input to Output	
Continuous	1500Vrms max
Transient	ANSI/IEEE C37.90.1
CMR (50 or 60Hz)	160dB
NMR	95dB at 60Hz, 90dB at 50Hz
Accuracy	See Ordering Information
Conformity Error ⁽³⁾	$\pm 0.025\%$ Span
Stability	
Input Offset	$\pm 0.01^\circ\text{C}/^\circ\text{C}$
Output Offset	$\pm 20\mu\text{V}/^\circ\text{C}$
Gain	$\pm 35\text{ppm}$ of Reading/ $^\circ\text{C}$
Noise	
Input, 0.1 to 10Hz	0.2μVrms
Output, 100kHz	200μVrms
Bandwidth, -3dB	4Hz
Response Time, 90% Span	0.2s
Output Range	See Ordering Information
Output Resistance	50Ω
Output Protection	Continuous Short to Ground
Output Selection Time (to $\pm 1\text{mV}$ of V_{OUT})	6μs at $C_{\text{load}} = 0$ to 2000pF
Output Current Limit	+8mA
Output Enable Control	
Max Logic "0"	+0.8V
Min Logic "1"	+2.4V
Max Logic "1"	+36V
Input Current "0,1"	0.5μA
Open Input Response	Downscale
Open Input Detection Time	3s
Power Supply Voltage	+5VDC $\pm 5\%$
Power Supply Current	30mA
Power Supply Sensitivity	
100Ω Pt, 120Ω Ni	0.2°C/V
10Ω Cu	0.5°C/V
Mechanical Dimensions (h)(w)(d)	2.28" x 2.26" x 0.60" (58mm x 57mm x 15mm)
Environmental	
Operating Temperature Range	-40°C to +85°C
Storage Temperature Range	-40°C to +85°C
Relative Humidity	0 to 95% Noncondensing
Emissions EN61000-6-4	ISM, Group 1
Radiated, Conducted	Class A
Immunity EN61000-6-2	ISM, Group 1
RF	Performance A $\pm 0.5\%$ Span Error
ESD, EFT	Performance B

Ordering Information

Model	Input Range	Output Range [†]	Accuracy ⁽²⁾
100Ω Pt ** SCM5B34-01	-100°C to +100°C (-148°F to +212°F)	3, 4	$\pm 0.12^\circ\text{C}$
SCM5B34-02	0°C to +100°C (+32°F to +212°F)	3, 4	$\pm 0.06^\circ\text{C}$
SCM5B34-03	0°C to +200°C (+32°F to +392°F)	3, 4	$\pm 0.12^\circ\text{C}$
SCM5B34-04	0°C to +600°C (+32°F to +1112°F)	3, 4	$\pm 0.36^\circ\text{C}$
SCM5B34-05	-100°C to +200°C (-148°F to +392°F)	3, 4	$\pm 0.18^\circ\text{C}$
10Ω Cu ** SCM5B34C-01	0°C to +120°C (10Ω at 0°C) (+32°F to +248°F)	3, 4	$\pm 0.23^\circ\text{C}$
SCM5B34C-02	0°C to +120°C (10Ω at 25°C) (+32°F to +248°F)	3, 4	$\pm 0.23^\circ\text{C}$
SCM5B34C-03	0°C to +160°C (10Ω at 0°C) (+32°F to +320°F)	3, 4	$\pm 0.32^\circ\text{C}$
120Ω Ni ** SCM5B34N-01	0°C to +300°C (+32°F to +572°F)	3, 4	$\pm 0.23^\circ\text{C}$

**** RTD Standards**

Type	Alpha Coefficient	DIN	JIS	IEC
100Ω Pt	0.00385	DIN 43760	JIS C 1604-1989	IEC 751
120Ω Ni	0.00672			
10Ω Cu	0.004274			

†Output Ranges Available

Output Range	Part No. Suffix	Example
3. 0V to +5V	NONE	SCM5B34-01
4. 0V to +10V	D	SCM5B34-01D

NOTES:

- * Contact factory or your local Dataforth sales office for maximum values.
- (1) "Ω" refers to the resistance in one lead.
- (2) Includes conformity, hysteresis and repeatability.
- (3) Conformity error is $\pm 0.05\%$ Span for SCM5B34N-01.