

# Analog Input Module: Strain Gage <sup>◇</sup>

## Interface to Full, Half, and Quarter Bridge Sensors

### Description

The MAQ20 strain gage input module offers 4 input channels and can interface to full, half, and quarter bridge sensors using 4-wire or 6-wire connections. All channels are individually configurable for range, alarms, and averaging to match the most demanding applications. In addition, sampling rate, resolution, bandwidth, excitation voltage, and shunt calibration are user settable parameters. Input signals are sampled simultaneously and burst mode can be used to capture fast events. High, Low, High-High and Low-Low alarms provide essential monitoring and warning functions to ensure optimum process flow and fail-safe applications. Hardware low-pass filtering in each channel provides rejection of unwanted frequencies. Field I/O connections are made through spring cage terminal blocks with positions designated for the termination of wiring shields.

Input-to-bus isolation is a robust 1500Vrms and each individual channel is protected up to 30Vrms continuous overload in case of inadvertent wiring errors. Overloaded channels do not adversely affect other channels in the module, which preserves data integrity.

Input ranges are selectable on a per-channel basis. Four ranges are available. Over-range and under-range up to 2% beyond the specified input values is allowed, and accuracy is guaranteed to  $\pm$ fs.

### ► Features

- 4 Input Channels for 4-Wire or 6-Wire Sensors
- Interface to Full, Half and Quarter (with external bridge completion) Sensors
- All Channels Individually Configurable for Range, Alarms, Averaging
- Programmable Sampling Rate & Resolution
- Simultaneous Sampling of Input Signals
- Burst Mode for Capturing Fast Events
- Programmable Bandwidth, Excitation, Shunt Calibration
- 1500Vrms Input-to-Bus Isolation
- Each Channel Protected up to 30Vrms Continuous Overload

<sup>◇</sup> Preliminary at date of printing.  
Contact factory for availability.

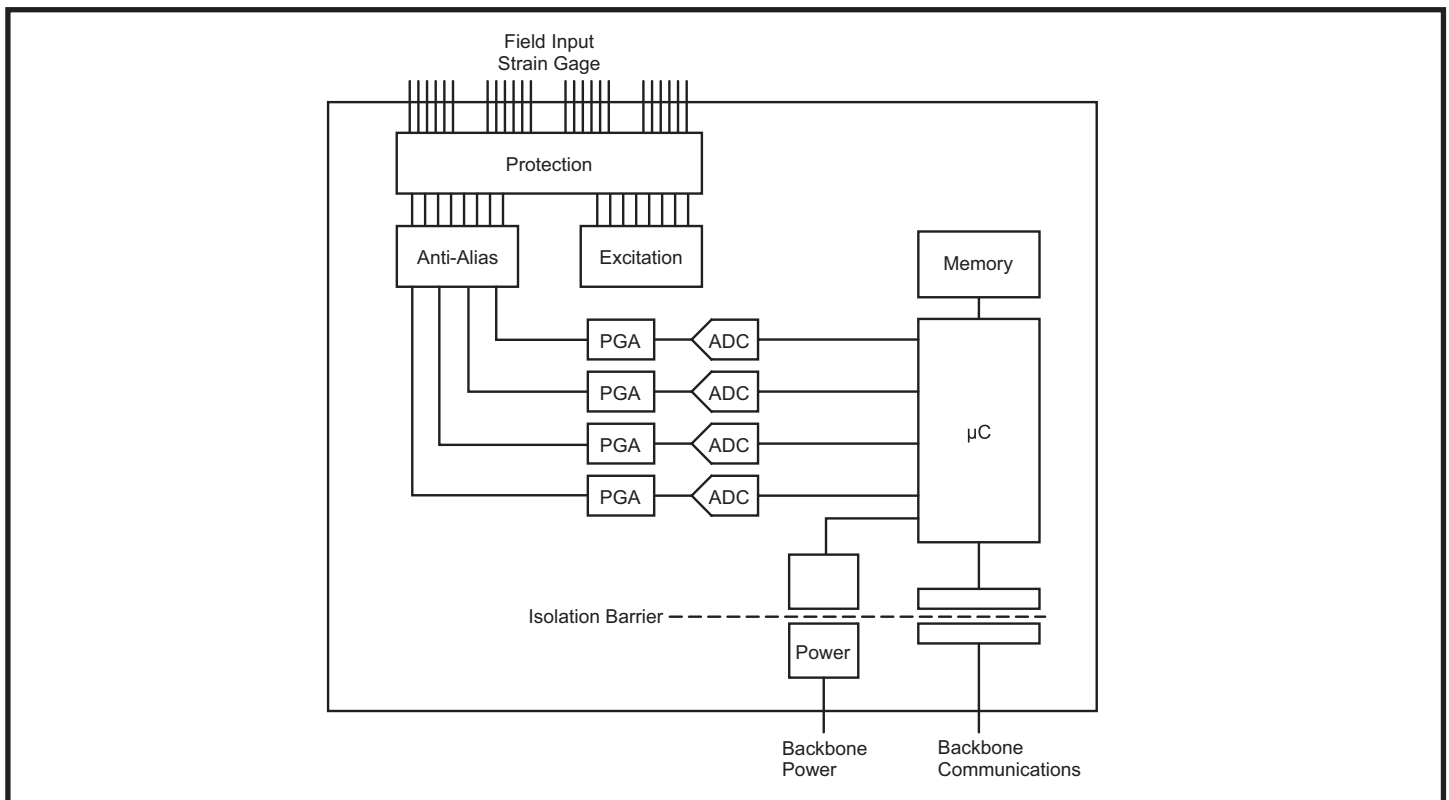

Figure 1: MAQ20 Strain Gage Input Module Block Diagram

**Specifications** Typical\* at T<sub>A</sub>=+25°C and +24VDC system power

Module	Description
MAQ20-BRDG1 <sup>◇</sup> Input Range Excitation Voltage Shunt Calibration	4-channel, Full, Half, Quarter Bridge (w/ Ext. Bridge Compl.) 4-wire or 6-wire connection 1.25mV/V, 2.5mV/V, 5mV/V, 10mV/V Sensitivity 2.5V, 3.333V, 5.0V, 10.0V 14.7kΩ, 43.2kΩ
Per Channel Setup Input Protection Continuous Transient CMV Channel-to-Bus Channel-to-Channel Transient CMR NMR	Individually configurable for range, alarms, averaging  30Vrms max ANSI/IEEE C37.90.1  1500Vrms, 1 min ±3V peak ANSI/IEEE C37.90.1 100dB at 50/60Hz 60dB/decade
Accuracy <sup>(1)</sup> Linearity Resolution Stability Zero Span	±0.03% span ±0.01% span 0.0005% to 0.005% span  ±50ppm/°C ±75ppm/°C
Bandwidth, -3dB Sampling Rate, Simultaneous Alarms Power Supply Current	Programmable to 10kHz 1kS/s to 64kS/s burst High / High-High / Low / Low-Low 600mA
Dimensions (h)(w)(d)	4.51" x 0.60" x 3.26" (114.6mm x 15.3mm x 82.8mm)
Environmental Operating Temperature Storage Temperature Relative Humidity Emissions, EN61000-6-4 Radiated, Conducted Immunity EN61000-6-2 RF ESD, EFT	-40°C to +85°C -40°C to +85°C 0 to 95% Noncondensing ISM Group 1 Class A ISM Group 1 Performance A ±0.5% Span Error Performance B
Certifications	Heavy Industrial CE, ATEX Pending UL Class I, Division 2, Groups A, B, C, D Pending

**NOTES:**

\* Contact factory or your local Dataforth sales office for maximum values.

<sup>◇</sup> Preliminary at date of printing. Contact factory for availability.

(1) Includes conformity, hysteresis and repeatability.

**Ordering Information**

Model	Description
MAQ20-BRDG1 <sup>◇</sup>	Analog Input Module; Bridge/Strain Gage, 4-ch

**For input connections and full details on module operation, refer to MA1046 – MAQ20 Strain Gage Input Module Hardware User Manual, available for download at: [www.dataforth.com/maq20\\_download.aspx](http://www.dataforth.com/maq20_download.aspx)**