

► **Accessories for SCM5B Analog Modules**

► **Features**

- 1-, 2-, 8-, 16-Position Backpanels
- Panel or DIN Rail Mounting Options
- 19-Inch Mounting Rack For Backpanels
- Multiplexed and Non-Multiplexed Backpanels
- Interface Cables
- Module Evaluation Board
- Cable-to-Screw-Terminal Interface Board
- Power Supplies

# SCMPB01

## 16-Position Analog I/O Backpanel, Non-Multiplexed



### Description

The SCMPB01 16-channel backpanel (Figure 1) can accept any of the SCM5B analog modules in any mixture. It can be mounted on the SCMXRK-002 19-inch metal rack. The SCMPB01 has 16 non-addressable analog I/O signal channels which provides each module with it's own analog bus. The module output switch is continuously "on" when using this backpanel and all sixteen module outputs are simultaneously accessible to high-speed data acquisition (ADC) boards. A set of inter-channel bridge jumpers permits connecting an input module's output to an output module's input, providing two levels of isolation. A temperature sensor is mounted on each channel to provide cold junction compensation for thermocouple input modules (see Figure 2 for schematic). Field connections are terminated with four screw terminals at each module site. Use system interface cable SCMXCA004-XX for connection to the host system.

### Specifications

Operating Temperature	-40°C to +85°C
Relative Humidity	95% Noncondensing
Interface Connector: Field System	high density screw clamp, 14 AWG max 26-pin, male header connector
Isolation: Input-to-Output Channel-to-Channel	1500Vrms continuous, max 1500Vrms continuous, max

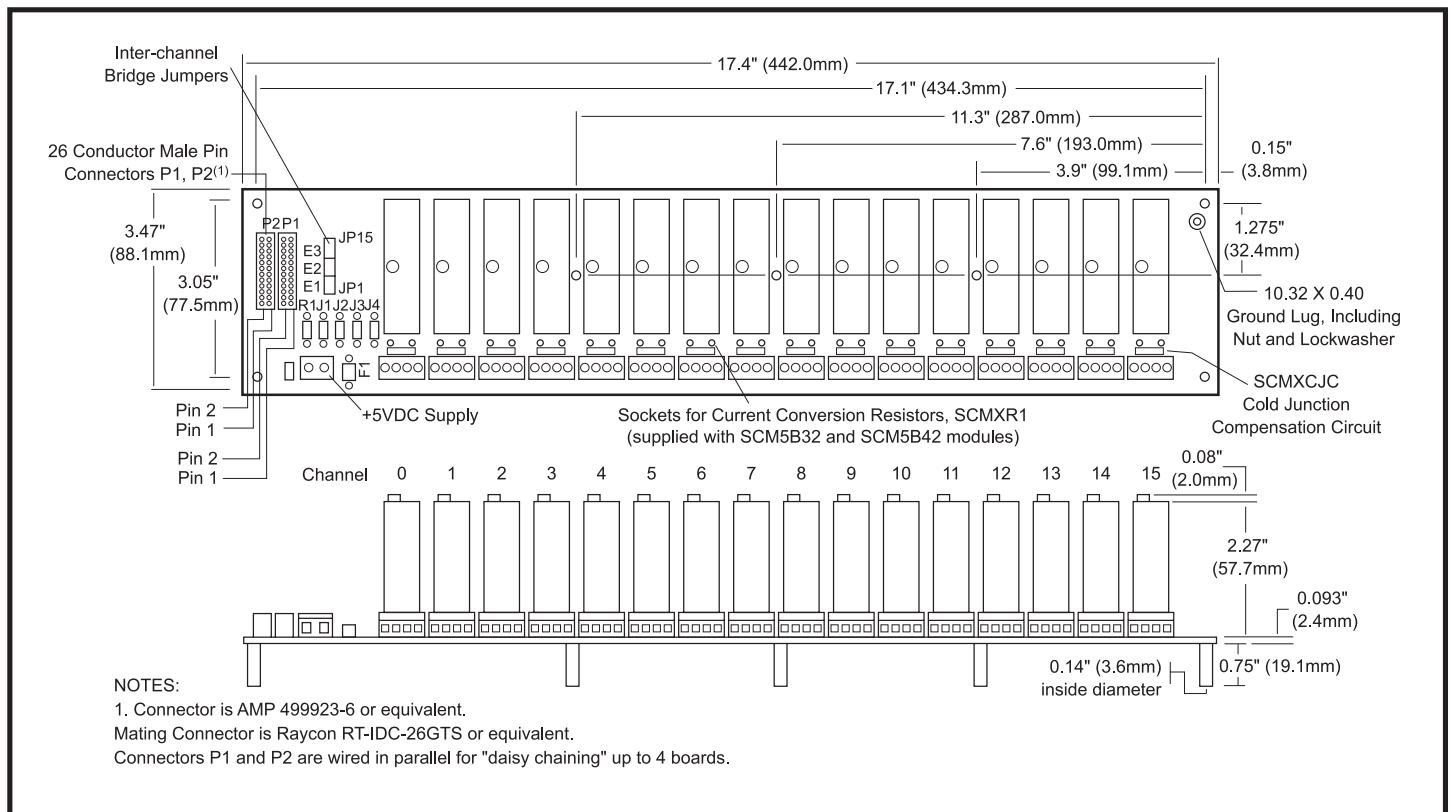
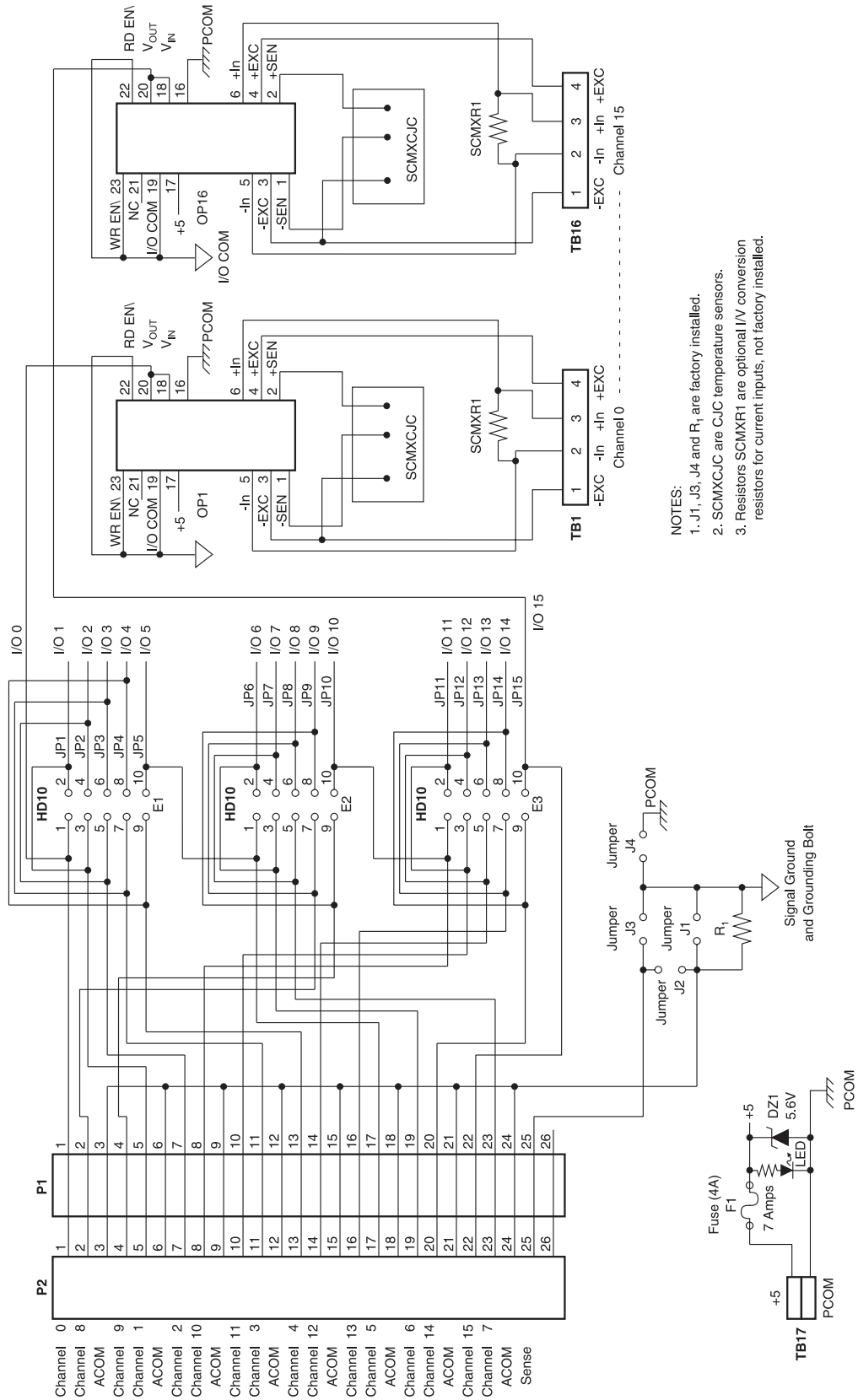

Figure 1: SCMPB01 Analog I/O Backpanel



- NOTES:
1. J1, J3, J4 and R<sub>1</sub> are factory installed.
  2. SCMXCJC are CJC temperature sensors.
  3. Resistors SCMXR1 are optional I/V conversion resistors for current inputs, not factory installed.

Figure 2: SCMPB01 Schematic

**Electrical**

**P1 and P2 Connector**

Connection to the host system is made at connectors P1 and P2. These connectors are electrically equivalent. Two connectors are provided to allow both analog input and analog output from host systems having individual input and output connectors.

**Adjacent Channel Jumpers**

Adjacent channels may be connected together to provide an isolated output signal from an isolated input module, providing two levels of 1500V isolation. This capability is provided with the 15 jumpers labeled JP1 through JP15 on headers E1, E2, and E3. A simplified drawing of the SCMPB01 schematic for Channel 1 through 4 is shown in Figure 3.

Example: Assume an SCM5B30 input module is installed in Channel 0 position and an SCM5B39 output module is installed in Channel 1 position. If JP1 is installed, the output of Channel 0 is connected to the input of Channel 1, which provides two levels of 1500V isolation.

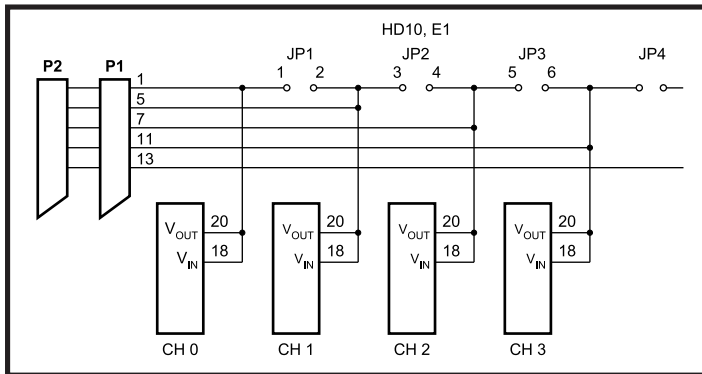

Figure 3: SCMPB01 Adjacent Channel Jumpers

**Power**

The SCMPB01 backpanel requires external +5VDC ±5% power. The chassis mounted SCMXPRE-003 or SCMXPR-003 power supplies have adequate capacity to power any combination of modules.

**Fusing**

The SCMPB01 backpanel power is fuse protected through F1. This is a Littelfuse type 252007, 7 amp fuse. Zener diode DZ1 provides extra protection by clamping the input power voltage to +5.6V. If the input supply voltage connection is reversed, this zener diode will be forward biased and fuse F1 will be blown.

**Grounding**

Figure 4 details the optional ground jumper configuration available on the SCMPB01 backpanel. Jumpers J1, J3, and J4 are factory installed.

Jumper J1 connects the AGND shield wires (pins 3, 6, 9, 12, 15, 18, 21, and 24) to the backpanel signal ground. This provides a ground connection between the host system and backpanel. Jumper J1 is required if output modules (SCM5B39, SCM5B49) are used, or if there is no high impedance sense input (input low of a differential or pseudo-differential system) on the host measurement system.

Jumper J3 connects the SENSE line (pin 25) to the backpanel signal ground. If the host system has the capability, this allows measuring the SCMPB01 ground potential.

**Ordering Information**

Part Number	Description
SCMPB01	16-channel backpanel with standoffs for mounting.
SCMPB01-1	16-channel backpanel without cold junction compensation circuits and standoffs for mounting. Use when cost savings is desired and thermocouple input modules SCM5B37 and SCM5B47 will not be used.
SCMPB01-2	16-channel backpanel with DIN rail mounting option. The backpanel is mounted on a plate which is captured by the SCMXBExx DIN rail mounting elements. Shipped fully assembled.
SCMPB01-3	16-channel backpanel without cold junction compensation circuits and with DIN rail mounting option. Shipped fully assembled.

For proper operation of the output switch or track-and-hold circuit when using the SCMPB01/05 backpanels, a current path must exist between the host control logic power common and module I/O Common (module pin 19). This path can be established on the SCMPB01 via jumper J4. If this connection exists elsewhere in the system, jumper J4 should be removed since possible ground loops could exist. Other connections of power ground and signal ground usually occur at the A/D or D/A converter of the host measurement system. More information on grounding can be found in Application Note AN502.

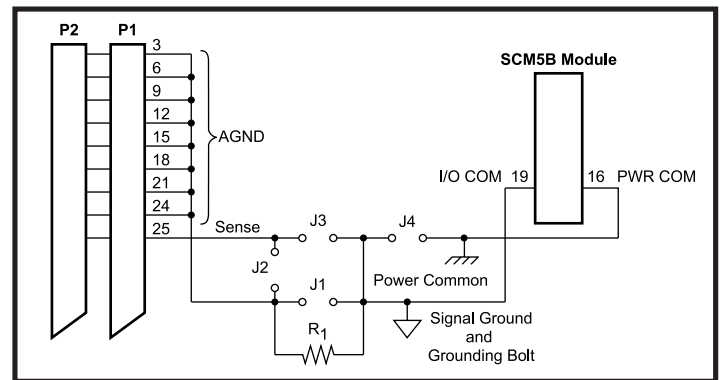

Figure 4: SCMPB01 Grounding Diagram

If the connection of power common and AGND shield wires exist in the host measurement system, an optional resistive connection between AGND and the backpanel signal ground can be made via R<sub>1</sub>. R<sub>1</sub> can be as large as 10K ohms; 100 ohms is a recommended value. Jumper J2 can be used to connect the SENSE line to R<sub>1</sub> when this ground configuration is used.

For full protection against large electrical disturbances on the field-side of the SCM5B modules, a #10-32 ground stud is provided on the backpanel. An electrical connection between this ground stud and system ground should be provided with a large gauge wire of the shortest possible length. When this connection is made, a possible ground loop could result through the AGND shield wires and backpanel signal ground. If the application involves only input modules and a differential input is used by the host measurement system, J1 should be removed. Remember that J1 is required if output modules are used or if the host system does not have differential inputs.

# SCMPB02

## 16-Position Analog I/O Backpanel, Multiplexed



SCM5B

### Description

The SCMPB02 16-channel backpanel (Figure 5) can accept any of the SCM5B analog modules in any mixture. It can be mounted on the SCMXRK-002 19-inch metal rack. The SCMPB02 has two analog buses; one for analog input and one for analog output. This two-bus configuration takes advantage of the switch controlled outputs on the input modules and the track-and-hold inputs on the output modules. A temperature sensor is mounted on each channel to provide cold junction compensation for thermocouple input modules (see Figure 6 for schematic). Field connections are terminated with four screw terminals at each module site. Up to four SCMPB02 backpanels may be daisy-chained. Use SCMXCA004-XX cable for daisy chaining and connecting to host computer.

### Specifications

Operating Temperature	-40°C to +85°C
Relative Humidity	95% Noncondensing
Interface Connector: Field System	high density screw clamp, 14 AWG max 26-pin, male header connector
Isolation: Input-to-Output Channel-to-Channel	1500Vrms continuous, max 1500Vrms continuous, max
Address Input Logic Levels: Max Logic "0" Min Logic "1"	0.8V 2.0V
I <sub>i</sub> Input Current, "0" or "1"	0.1µA max at 25°C 1.0µA max -25°C to +85°C
RD EN\ or WR EN\ Signal Delay from Connector P1 to Channels 1-16 Standalone (address 0-15) Expanded (address 16-63)	51ns at 25°C 64ns at -25°C to +85°C 100ns at 25°C 126ns at -25°C to +85°C

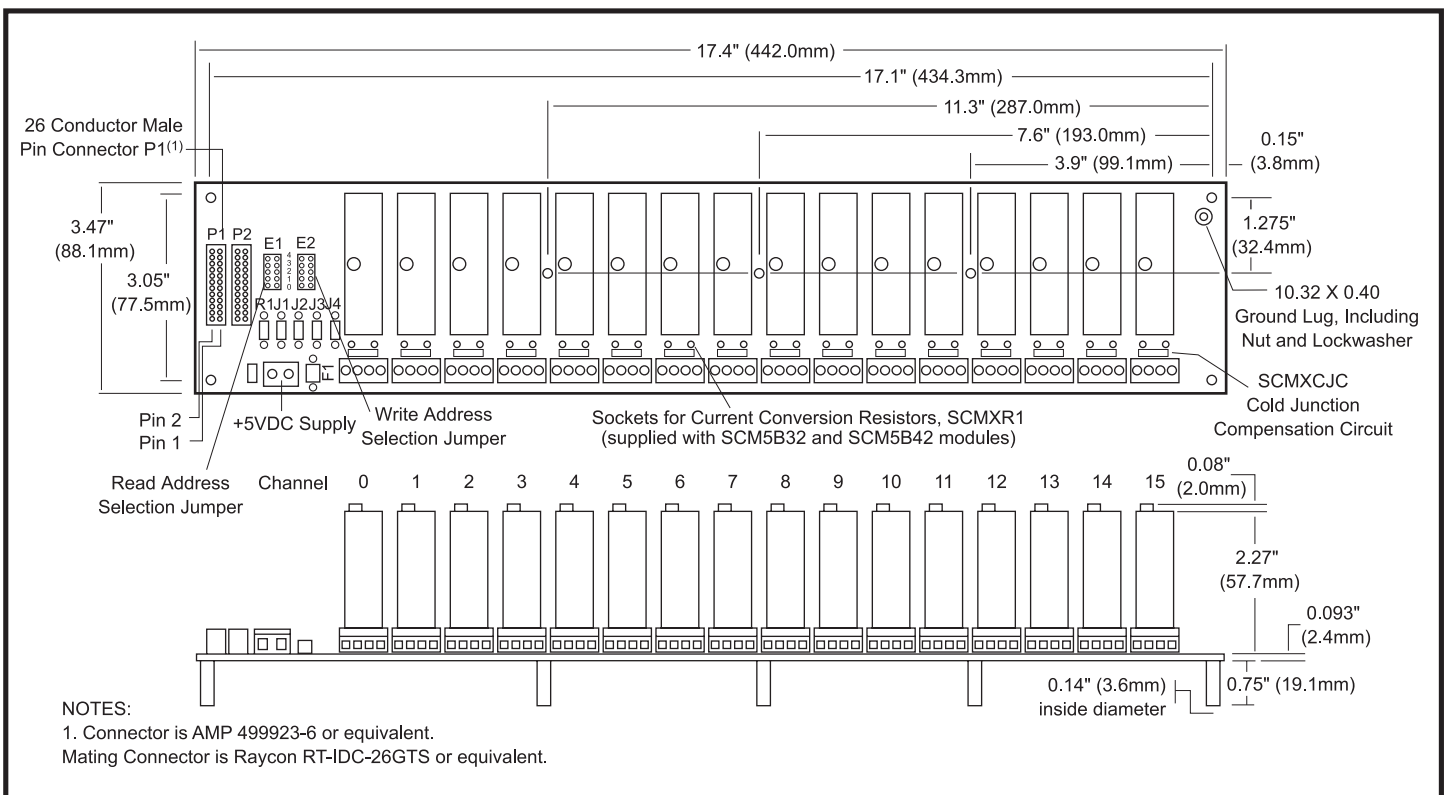
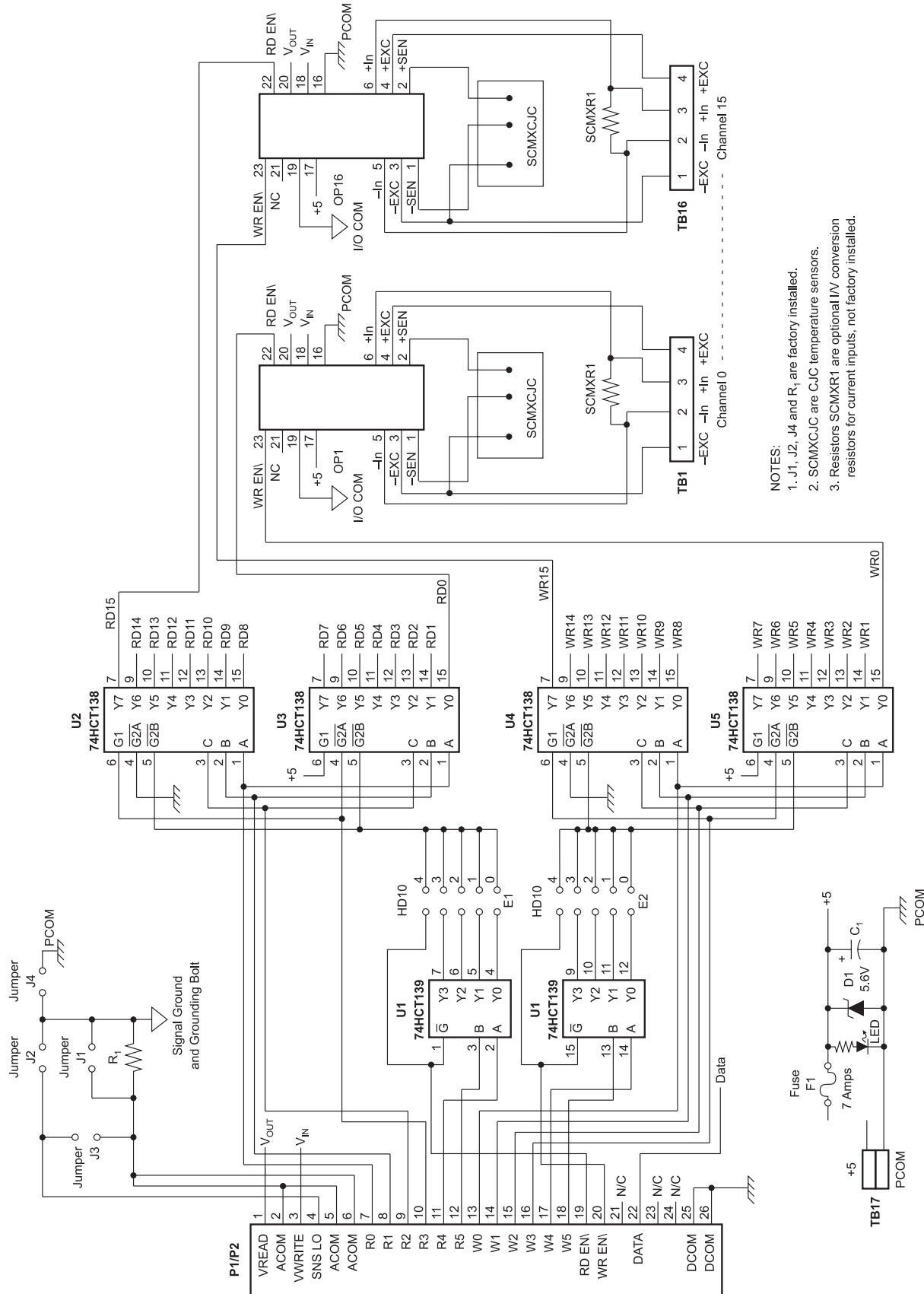

Figure 5: SCMPB02 Analog I/O Backpanel



NOTES:  
 1. J1, J2, J4 and R<sub>1</sub> are factory installed.  
 2. SCMXCJC are CJC temperature sensors.  
 3. Resistors SCMXR1 are optional I/V conversion resistors for current inputs, not factory installed.

Figure 6: SCMPB02 Schematic

**Electrical**

**P1 Connector**

The 26 pin P1 and P2 connectors provide the signal interface between the SCMPB02 backpanel and the host measurement system. Two separate analog bus connections are provided; one for analog input signals and one for analog output signals. Two sets of six address lines and an enable pin allow input and output modules to be independently multiplexed onto their respective analog signal bus. R0 thru R5 and RD EN\ are used for input modules, and W0 thru W5 and WR EN\ are used for output modules.

**Address Selection**

The SCMPB02 backpanel has address decoding circuitry to allow multiplexing any combination of up to 16 input or output modules. Capability is also provided in the address decode circuitry to expand the system to 64 channels (four SCMPB02 backpanels) of multiplexed input or output. Jumpers on HD10 header, E1 and E2 group, select which set of 16 addresses are assigned to a particular backpanel. The E1 group assigns a set of 16 addresses for input modules, and the E2 group assigns a set of 16 addresses for output modules. The table below shows the correlation of jumper position to address range.

E1 Jumper Pos	E2 Jumper Pos	Address Range/Mode
4	4	0-15, STAND ALONE
3	3	48-63, EXPANDED
2	2	32-47, EXPANDED
1	1	16-31, EXPANDED
0	0	0-15, EXPANDED

To connect multiple SCMPB02 backpanels in this expanded configuration, use interconnect cable SCMXCA004-XX.

Modules with system output of ±10V or 0-10V cannot be mixed with modules with system output of ±5V or 0-5V within a given system.

**Power**

The SCMPB02 backpanel requires external +5VDC ±5% power. The chassis mounted SCMXPRE-003 or SCMXPRT-003 power supplies have adequate capacity to power any combination of modules.

**Fusing**

The SCMPB02 backpanel power is fuse protected through F1. This is a Littelfuse type 252007, 7 amp fuse. Zener diode DZ1 provides extra protection by clamping the input power voltage to +5.6V. If the input supply voltage connection is reversed, this zener diode will be forward biased and fuse F1 will be blown.

**Grounding**

Figure 7 below details the optional ground jumper configuration available on the SCMPB02 backpanel. Jumpers J1, J2, and J4 are factory installed.

Jumper J1 connects the SIG COM shield wires (pins 2, 5, and 6) to the backpanel signal ground. This provides a ground connection between the host system and backpanel. Jumper J1 is required if output modules (SCM5B39, SCM5B49) are used, or if there is no high impedance sense input (input low of a differential or pseudo-differential system) on the host measurement system.

Jumper J2 connects the SNS LO line (pin 4) to the backpanel signal ground. If the host system has the capability, this allows measuring the SCMPB02 ground potential.

**Ordering Information**

Part Number	Description
SCMPB02	16-channel backpanel with standoffs for mounting.
SCMPB02-1	16-channel backpanel without cold junction compensation circuits and standoffs for mounting. Use when cost savings is desired and thermocouple input modules SCM5B37 and SCM5B47 will not be used.
SCMPB02-2	16-channel backpanel with DIN rail mounting option. The backpanel is mounted on a plate which is captured by the SCMXBExx DIN rail mounting elements. Shipped fully assembled.
SCMPB02-3	16-channel backpanel without cold junction compensation circuits and with DIN rail mounting option. Shipped fully assembled.

For proper operation of the output switch or track-and-hold circuit when using the SCMPB02/06 backpanels, a current path must exist between the host control logic power common and module I/O Common (module pin 19). This path can be established on the SCMPB02 via jumper J4. If this connection exists elsewhere in the system, jumper J4 should be removed since possible ground loops could exist. Other connections of power ground and signal ground usually occur at the A/D or D/A converter of the host measurement system. More information on grounding can be found in Application Note AN502.

If the connection of power common and SIG COM shield wires exist in the host measurement system, a resistive connection between SIG COM and the backpanel signal ground can be made via R<sub>1</sub>. R<sub>1</sub> can be as large as 10K ohms; 100 ohms is a recommended value. Jumper J3 can be used to connect the SNS LO line to R<sub>1</sub> when this ground configuration is used.

For full protection against large electrical disturbances on the field-side of the SCM5B modules, a #10-32 ground stud is provided on the backpanel. An electrical connection between this ground stud and system ground should be provided with a large gauge wire of the shortest possible length. When this connection is made, a possible ground loop could result through the SIG COM shield wires and backpanel signal ground. If the application involves only input modules and a differential input is used by the host measurement system, J1 should be removed. Remember that J1 is required if output modules are used or if the host system does not have differential inputs.

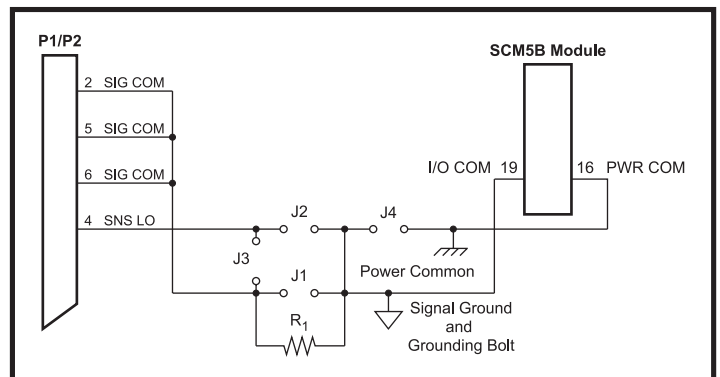

Figure 7: SCMPB02 Grounding Diagram



# SCMPB03/SCMPB04

## One/Two Position Analog I/O Backpanels

### Description

The SCMPB03 and SCMPB04 are single and dual channel mounting panels for the SCM5B modules. Both are intended for DIN rail mounting.

See Figures 9 and 10 for wiring diagrams, Figure 11 for schematic.

The following accessories are required for mounting one SCMPB03/04 panel (Figure 8):

Qty	Model	Description
1	SCMXBEFE	Base element with snap foot
2	SCMXSE	Side element

The following accessories are required for mounting two or more SCMPB03/04 panels:

Qty	Model	Description
2	SCMXBEFE	Base element with snap foot
2	SCMXSE	Side element
(# panels)-2	SCMXBE	Base element without snap foot
(4 x (# panels))-4	SCMXVS	Connection pins

The following DIN rail styles are available. Specify length in meters (-XX)

SCMXRAIL1-XX	DIN EN 50022-35x7.5 (slotted steel)
SCMXRAIL2-XX	DIN EN 50035-G32 (slotted steel)
SCMXRAIL3-XX	DIN EN 50022-35x15 (slotted steel)

### Specifications

Operating Temperature	-40°C to +85°C
Relative Humidity	95% Noncondensing
Interface Connector:	
Field System	high density screw clamp, 14 AWG max
Isolation:	
Input-to-Output	1500Vrms continuous, max
Channel-to-Channel	1500Vrms continuous, max

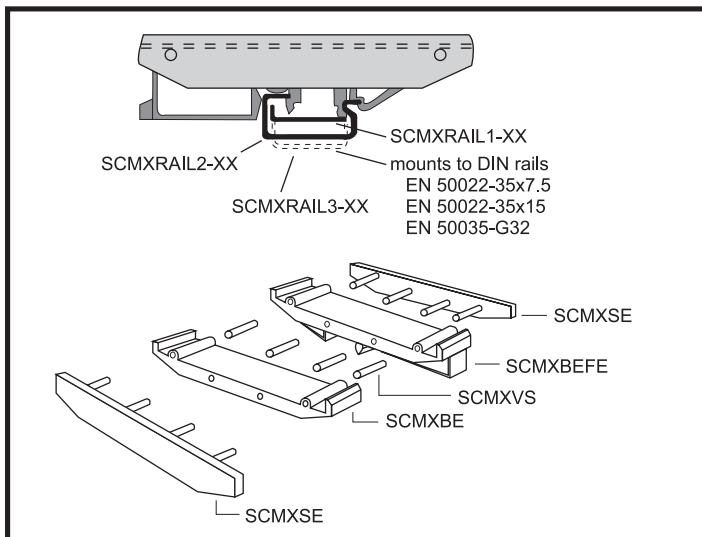

Figure 8: DIN Rail Mounting Elements

### Ordering Information

Part Number	Description
SCMPB03	Single channel backpanel. No mounting hardware included.
SCMPB03-2	Single channel backpanel with DIN rail mounting hardware. Shipped fully assembled.
SCMPB04	Dual channel backpanel. No mounting hardware included.
SCMPB04-1	Dual channel backpanel without cold junction compensation circuits. Use when cost savings is desired and thermocouple input modules SCM5B37 and SCMPB47 will not be used. No mounting hardware included.
SCMPB04-2	Dual channel backpanel with DIN rail mounting hardware. Shipped fully assembled.
SCMPB04-3	Dual channel backpanel without cold junction compensation circuits and with DIN rail mounting hardware. Shipped fully assembled.

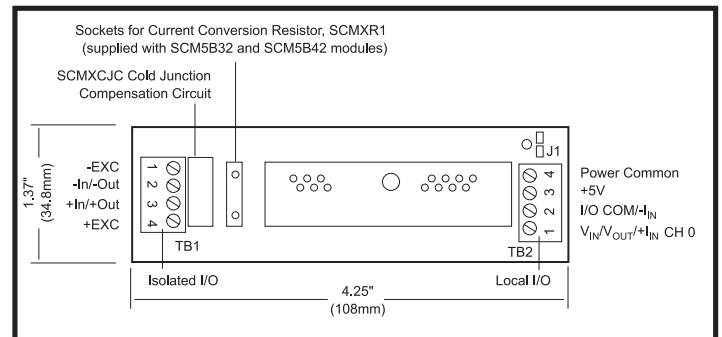

Figure 9: SCMPB03 Analog I/O Backpanel

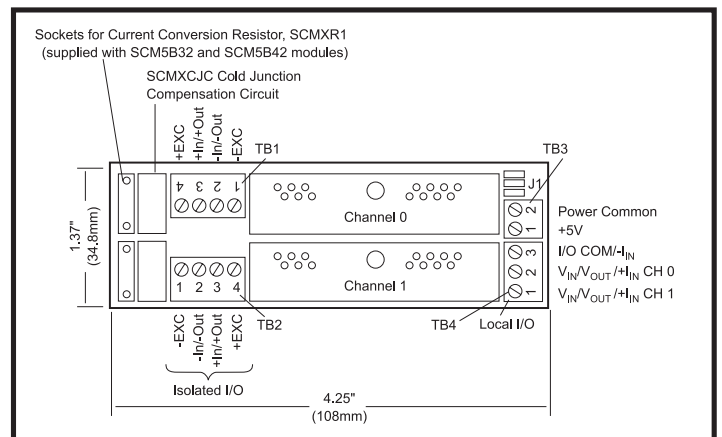
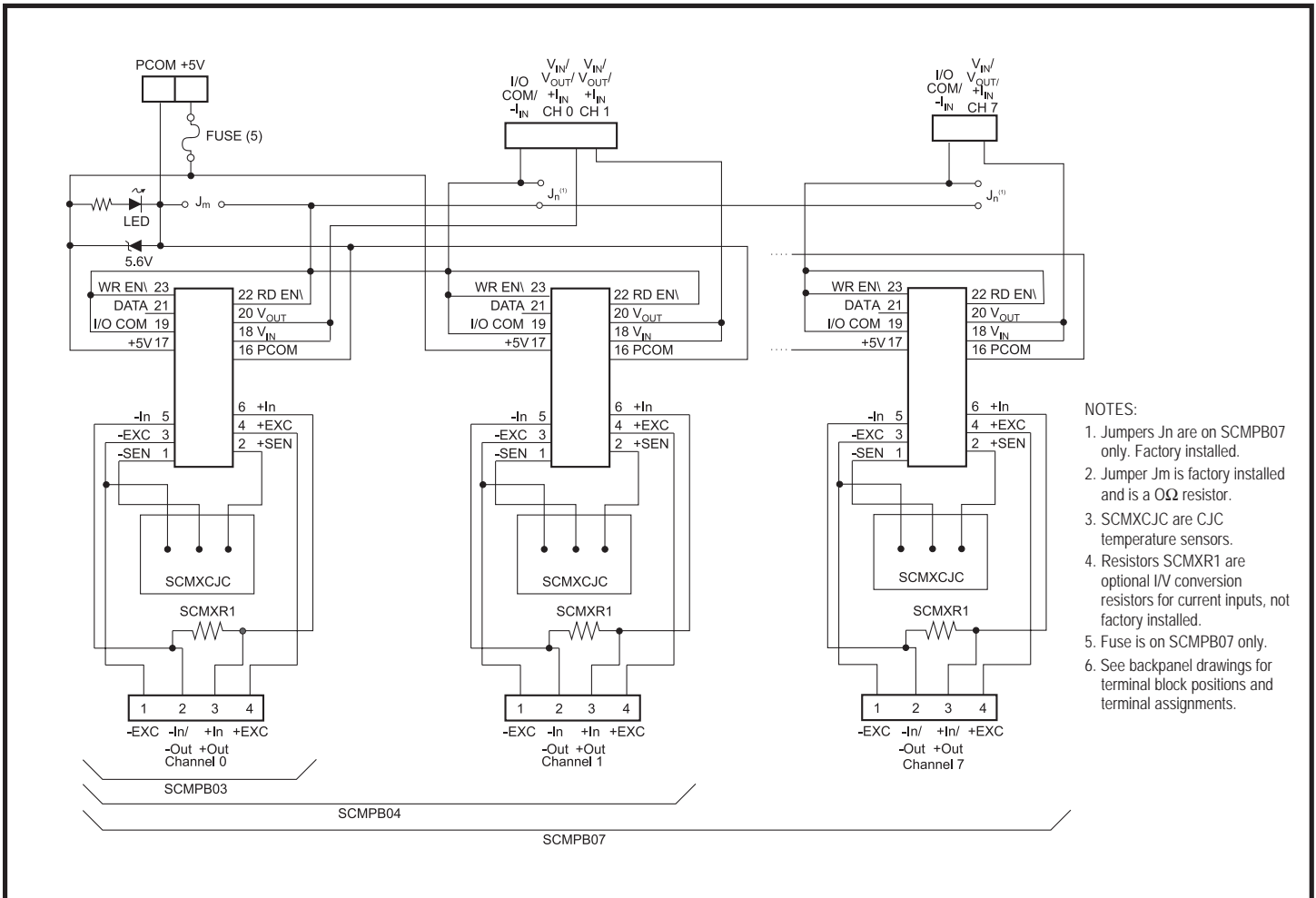

Figure 10: SCMPB04 Analog I/O Backpanel



- NOTES:
1. Jumpers Jn are on SCMPB07 only. Factory installed.
  2. Jumper Jm is factory installed and is a 0Ω resistor.
  3. SCMXCJC are CJC temperature sensors.
  4. Resistors SCMXR1 are optional I/V conversion resistors for current inputs, not factory installed.
  5. Fuse is on SCMPB07 only.
  6. See backpanel drawings for terminal block positions and terminal assignments.

Figure 11: SCMPB03/SCMPB04/SCMPB07 Schematic

# SCMPB05

## 8-Position Analog I/O Backpanel, Non-Multiplexed



### Description

The SCMPB05 backpanel (Figure 12) can accept up to eight SCM5B analog input and/or output modules in any combination. It can be mounted on the SCMXRK-002 19-inch metal rack. A separate analog signal path is provided for each channel and each channel's signal is accessible at redundant 26-pin connectors. The module output switch is continuously "on" when using this backpanel and all eight module outputs are simultaneously accessible to high-speed data acquisition (ADC) boards.

On-board jumpers permit paralleling two SCMPB05 boards to form a SCMPB01 equivalent. An additional set of inter-channel bridge jumpers permits connecting an input module's output to an output module's input, providing two levels of isolation (Figures 12, 13).

Jumpers on the SCMPB05 permit user selection of low (i.e. channels 0-7) or high (i.e. channels 8-15) addresses.

A temperature sensor mounted on each channel provides cold junction compensation for thermocouple input modules (see Fig. 13 for schematic). Field connections are terminated with four screw terminals at each module site. Use system interface cable SCMXA004-XX for connection to the host system.

### Specifications

Operating Temperature	-40°C to +85°C
Relative Humidity	95% Noncondensing
Interface Connector: Field System	high density screw clamp, 14 AWG max 26-pin, male header connector
Isolation: Input-to-Output Channel-to-Channel	1500Vrms continuous, max 1500Vrms continuous, max

### Ordering Information

Part Number	Description
SCMPB05	8-channel backpanel with standoffs for mounting.
SCMPB05-1	8-channel backpanel without cold junction compensation circuits and standoffs for mounting. Use when cost savings is desired and thermocouple input modules SCM5B37 and SCM5B47 will not be used.
SCMPB05-2	8-channel backpanel with DIN rail mounting option. The backpanel is mounted on a plate which is captured by the SCMxBExx DIN rail mounting elements. Shipped fully assembled.
SCMPB05-3	8-channel backpanel without cold junction compensation circuits and with DIN rail mounting option. Shipped fully assembled.

### Electrical

#### Address Selection

Module addresses may be selected as low (channels 0-7) or high (channels 8-15) using the sets of 3 pins labeled J5 through J12. Place a jumper over the two pins closest to the ribbon cable connectors, P1 and P2, to select a low address (factory configuration) or over the two pins furthest from the ribbon cable connectors, P1 and P2, to select a high address.

#### Adjacent Channel Jumper

Adjacent channels may be connected together to provide an isolated output signal from an isolated input module, providing two levels of 1500V isolation. This capability is provided with the seven jumpers labeled JP1-JP7. See page 57 for an example.

Refer to page 50 for additional notes on the P1 and P2 connectors, power requirements, fusing and grounding issues.

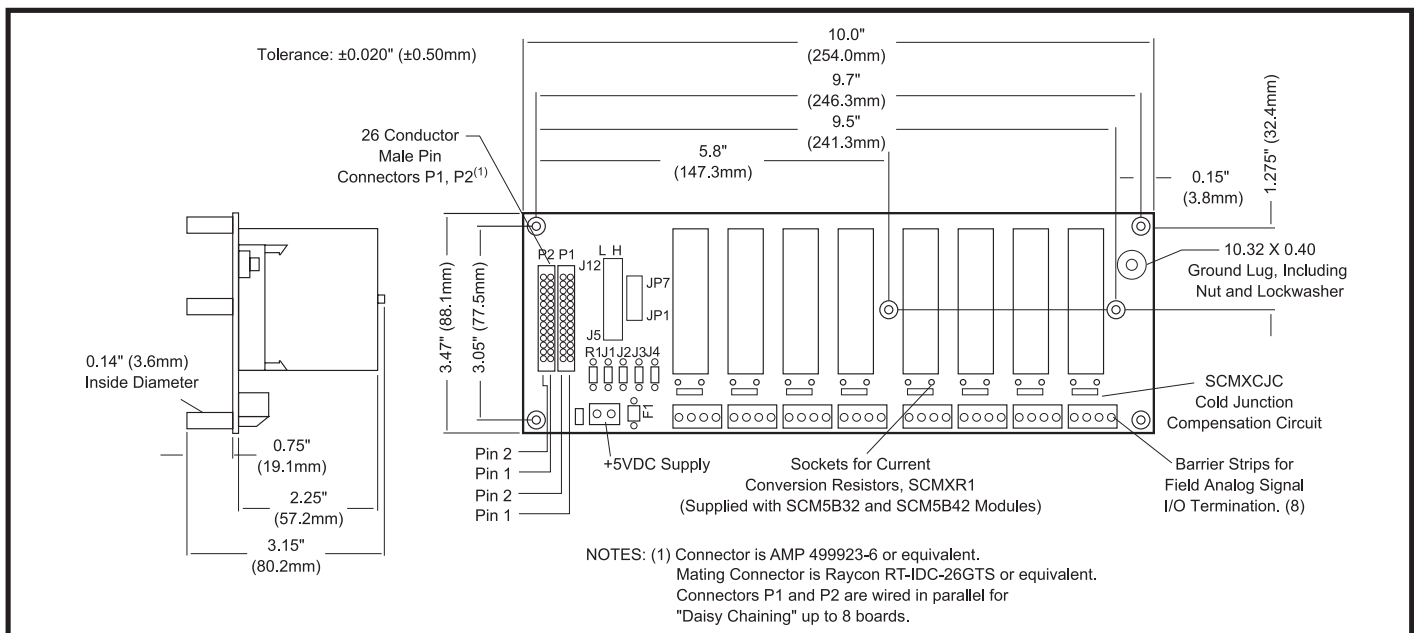
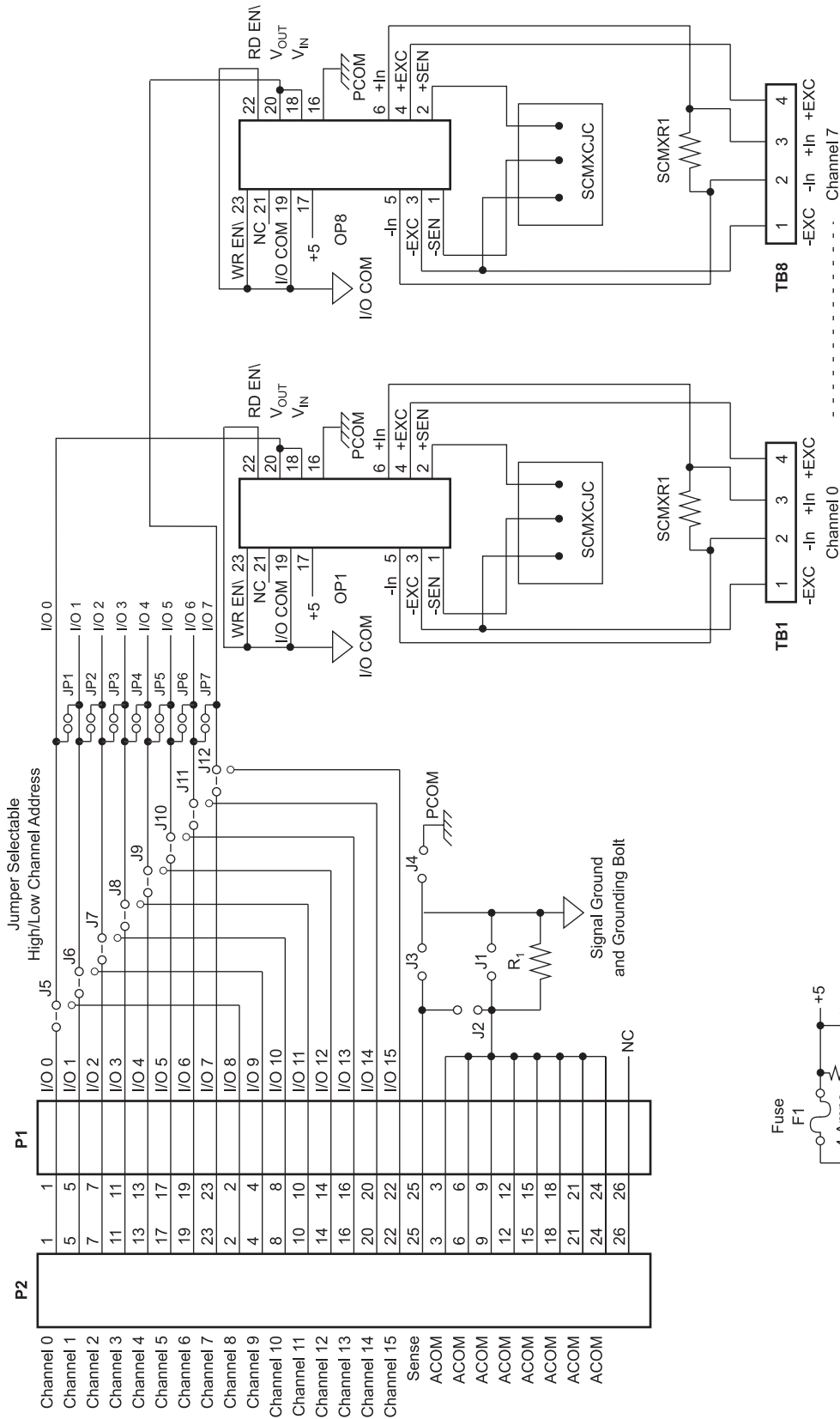

Figure 12: SCMPB05 Analog I/O Backpanel



- NOTES:
1. J1, J3, J4 and R<sub>1</sub> are factory installed.
  2. SCMXCJC are CJC temperature sensors.
  3. Resistors SCMXR1 are optional I/V conversion resistors for current inputs, not factory installed.

Figure 13: SCMPB05 Schematic



# SCMPB06

## 8-Position Analog I/O Backpanel, Multiplexed

### Description

The SCMPB06 backpanel (Figure 14) can accept up to eight SCM5B modules in any combination. It can be mounted on the SCMXRK-002 19-inch metal rack. The SCMPB06 has two analog buses; one for analog input and one for analog output. This two-bus configuration takes advantage of the switch controlled outputs on the input modules and the track-and-hold inputs on the output modules. A temperature sensor is mounted on each channel to provide cold junction compensation for thermocouple input modules (see Figure 15 for schematic). Field connections are terminated with four screw terminals at each module site. Up to eight SCMPB06 backpanels may be daisy-chained. Use SCMCA004-XX cable for daisy chaining and connecting to host computer.

Jumpers on the SCMPB06 permit user selection of low (i.e. channels 0-7) or high (i.e. channels 8-15) addresses.

### Electrical

#### Address Selection

Module read and write addresses may be selected as low (channels 0-7) or high (channels 8-15) using the four sets of 3 position jumpers labeled J5 through J8. Place a jumper over the two pins furthest from the field I/O termination blocks on all four sets to select a low address (factory configuration) or over the two pins closest to the field I/O termination blocks on all four sets to select a high address.

The SCMPB06 backpanel has address decoding circuitry to allow multiplexing any combination of up to 8 input or output modules. Capability is also provided in the address decode circuitry to expand the system to 64 channels (eight SCMPB06 backpanels) of multiplexed input or output. Jumpers select which set of 16 addresses are assigned to a particular backpanel. The Read Address group assigns a set of 16 addresses for input modules, and the Write Address group assigns a set of 16 addresses for output modules. The table on the next page shows the correlation of jumper position to address range. Refer to page 53 for additional notes on the P1 and P4 connectors, power requirements, fusing, and grounding issues.

Modules with system output of ±10V or 0-10V cannot be mixed with modules with system output of ±5V or 0-5V within a given system.

### Ordering Information

Part Number	Description
SCMPB06	8-channel backpanel with standoffs for mounting.
SCMPB06-1	8-channel backpanel without cold junction compensation circuits and standoffs for mounting. Use when cost savings is desired and thermocouple input modules SCM5B37 and SCM5B47 will not be used.
SCMPB06-2	8-channel backpanel with DIN rail mounting option. The backpanel is mounted on a plate which is captured by the SCMXBExx DIN rail mounting elements. Shipped fully assembled.
SCMPB06-3	8-channel backpanel without cold junction compensation circuits and with DIN rail mounting option. Shipped fully assembled.

### Specifications

Operating Temperature	-40°C to +85°C
Relative Humidity	95% Noncondensing
Interface Connector: Field System	high density screw clamp, 14 AWG max 26-pin, male header connector
Isolation: Input-to-Output Channel-to-Channel	1500Vrms continuous, max 1500Vrms continuous, max
Address Input Logic Levels: Max Logic "0" Min Logic "1"	0.8V 2.0V
I, Input Current, "0" or "1"	0.1µA max at 25°C 1.0µA max -25°C to +85°C
RD EN\ or WR EN\ Signal Delay from Connector P1 to Channels 0-7 Standalone (address 0-7) Expanded (address 8-63)	51ns at 25°C, 64ns at -25°C to +85°C 100ns at 25°C, 126ns at -25°C to +85°C

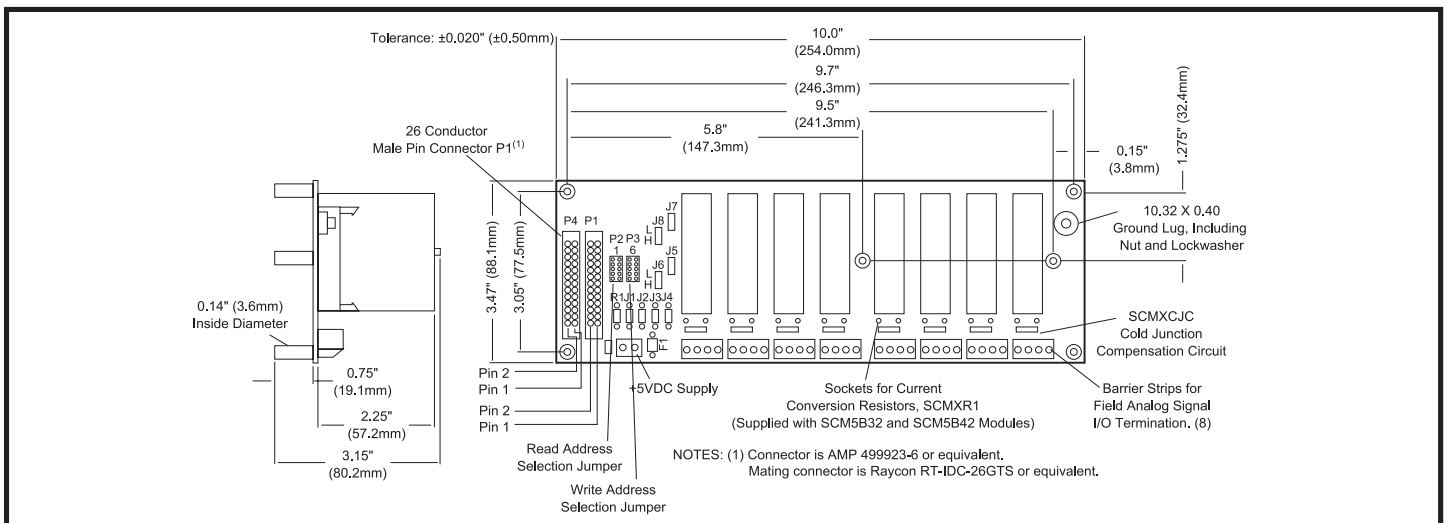
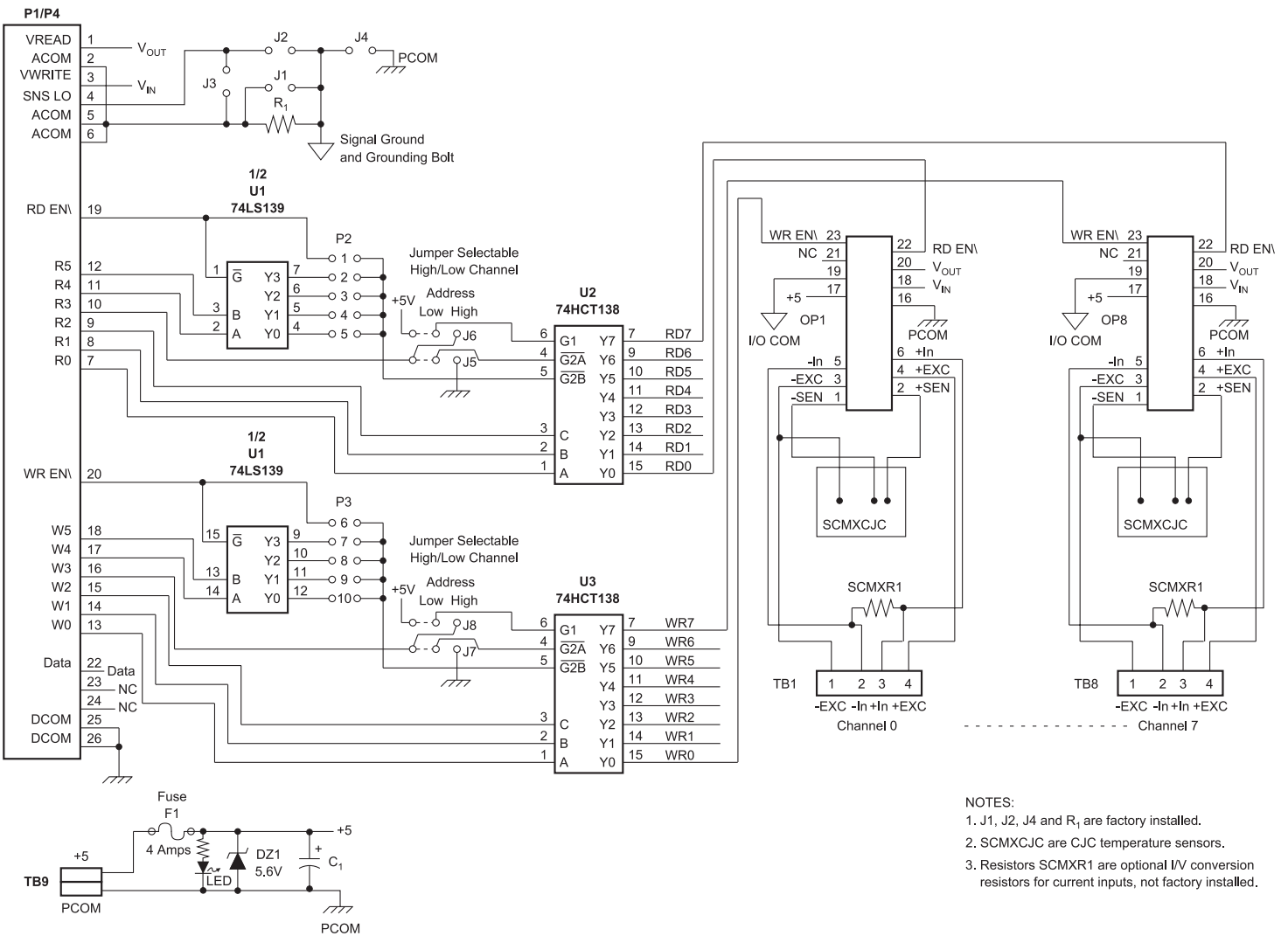

Figure 14: SCMPB06 Analog I/O Backpanel

Address Selection Jumpers

Read Address Jumper (P2)	Write Address Jumper (P3)	High/Low Channel Address (J5,J6,J7,J8)	Address Range
1	6	L	0-7 Stand Alone
1	6	H	8-15 Stand Alone
2	7	L	48-55 Expanded
2	7	H	56-63 Expanded
3	8	L	32-39 Expanded
3	8	H	40-47 Expanded
4	9	L	16-23 Expanded
4	9	H	24-31 Expanded
5	10	L	0-7 Expanded
5	10	H	8-15 Expanded



- NOTES:
1. J1, J2, J4 and R<sub>1</sub> are factory installed.
  2. SCMXCJC are CJC temperature sensors.
  3. Resistors SCMXR1 are optional I/V conversion resistors for current inputs, not factory installed.

Figure 15: SCMPB06 Schematic



# SCMPB07

## 8-Position Backpanel, High Density

### Description

The SCMPB07 8-channel high-density backpanel can accept any of the SCM5B analog modules in any mixture. Its overall width is 5.5 inches (139.7mm) versus 10 inches (254mm) for the SCMPB05 and SCMPB06 8-channel backpanels. Separate analog signal paths are provided for each channel. Each channel provides four high-density screw terminals for field connections and two high-density screw terminals for host system connection. It also provides a jumper on each channel to optionally connect or isolate each module's I/O common from other channel's I/O common and/or power common (Figure 16).

See Figure 11 on page 55 for schematic.

SCMPB07 and SCMPB07-1 can be upgraded to DIN rail mounting. The following accessories are required for mounting one SCMPB07 or one SCMPB07-1 backpanel (for a visual example, reference SCMPB03/SCMPB04 page 54, Figure 8):

### Ordering Information

Part Number	Description
SCMPB07	8-channel backpanel. No mounting hardware included.
SCMPB07-1	8-channel backpanel without cold junction compensation circuits. Use when cost savings is desired and thermocouple input modules SCM5B37 and SCMPB47 will not be used.
SCMPB07-2 Shipped	8-channel backpanel with DIN rail mounting hardware, fully assembled.
SCMPB07-3	8-channel backpanel without cold junction compensation circuits and with DIN rail mounting hardware. Shipped fully assembled.

### Specifications

Operating Temperature	-40°C to +85°C
Relative Humidity	95% Noncondensing
Interface Connector: Field System	high density screw clamp, 14 AWG max high density screw clamp, 14 AWG max
Isolation: Input-to-Output Channel-to-Channel	1500Vrms continuous, max 1500Vrms continuous, max

Qty	Model	Description
2	SCMXBEFE	Base element with snap foot
2	SCMXSE	Side element
2	SCMXBE	Base element without snap foot
12	SCMXVS	Connection pins

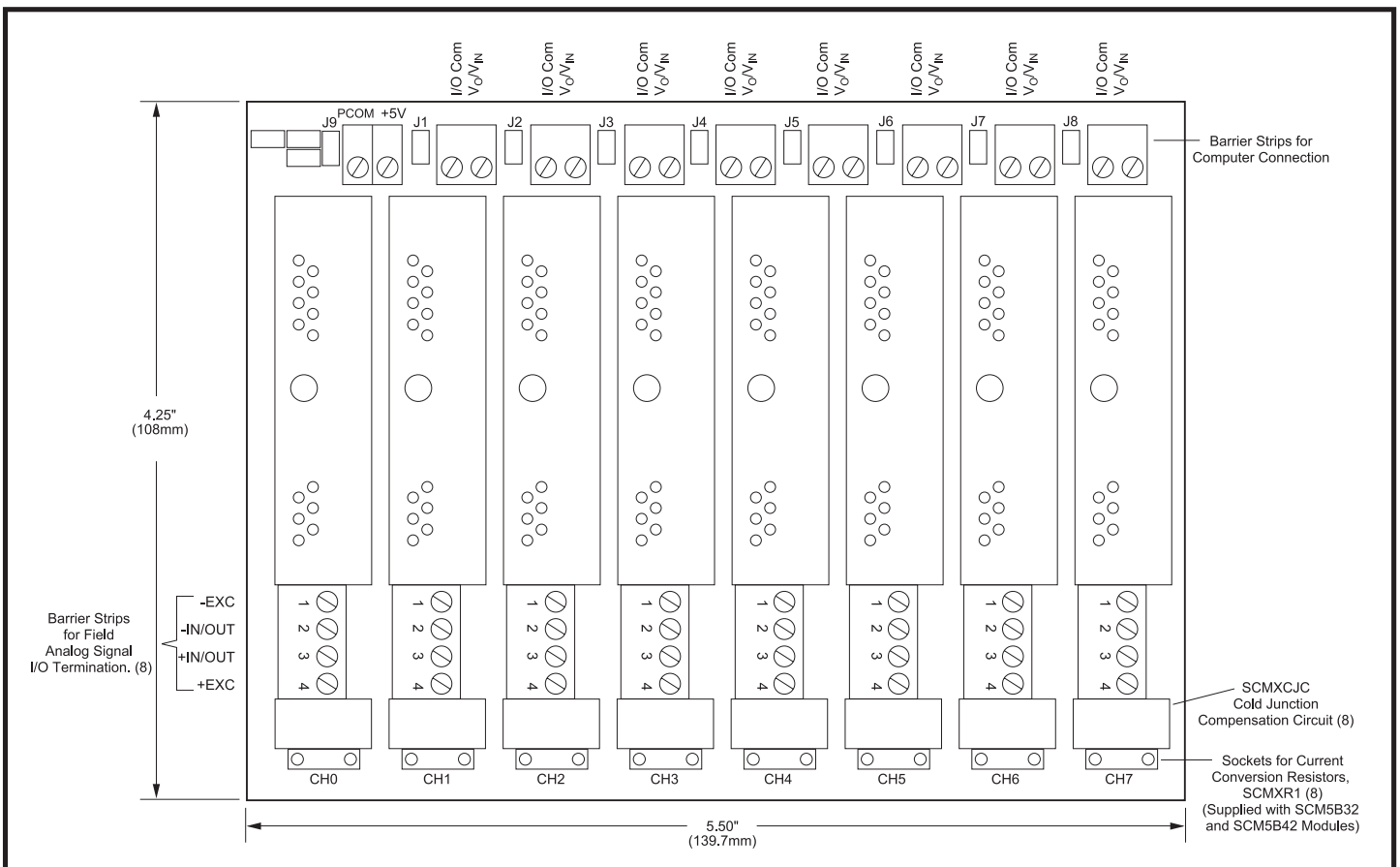

Figure 16: SCMPB07 Analog I/O Backpanel

# SCMXEV

## Analog Module Evaluation Board

### Description

The SCMXEV is a single channel board with a test socket for SCM5B module evaluation (Figure 17). All signal input/output, control, and power connections are connected to terminal blocks for ease of user access. A cold junction temperature sensor circuit is included for evaluation of thermocouple modules (see Figure 18 for schematic).

The SCMXEV is mechanically compatible with DIN rail mounting. The following accessories are required for mounting one SCMXEV board (for a visual example, reference SCMPB03/SCMPB04 page 54, Figure 8):

Qty	Model	Description
2	SCMXBEFE	Base element with snap foot
2	SCMXSE	Side element
4	SCMXVS	Connection pins

Two jumpers are provided for customer use. The first, J1, provides a current path between +5V Power Common (module pin 16) and I/O Common (module pin 19). A path must exist between the host control logic power common and module I/O Common for proper operation of the module output switch or track-and-hold circuit. If this connection exists elsewhere in the system, jumper J1 should be removed since possible ground loops could exist. Other connections of power ground and signal ground usually occur at the A/D or D/A converter of the host measurement system.

Jumper J2 is used in the cold junction compensation circuit. If it is installed, the compensation circuit is enabled and will provide the proper compensation voltage to correct for the thermoelectric effect at the +In and -In screw terminals.

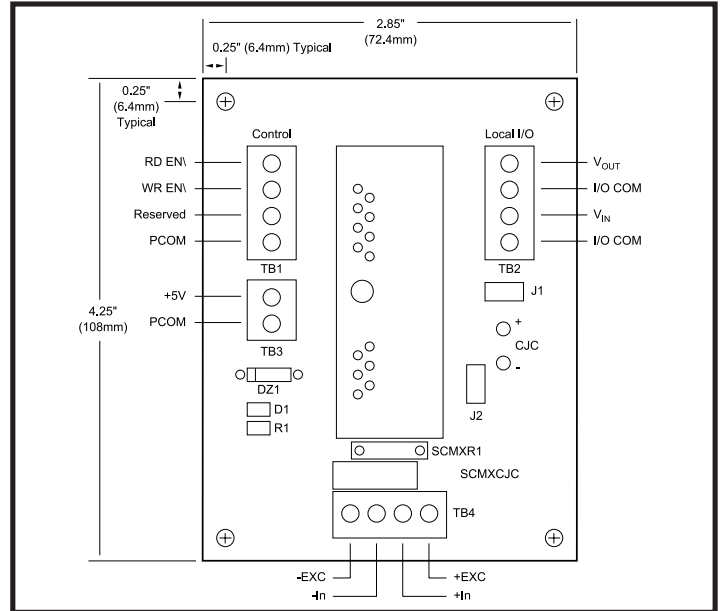
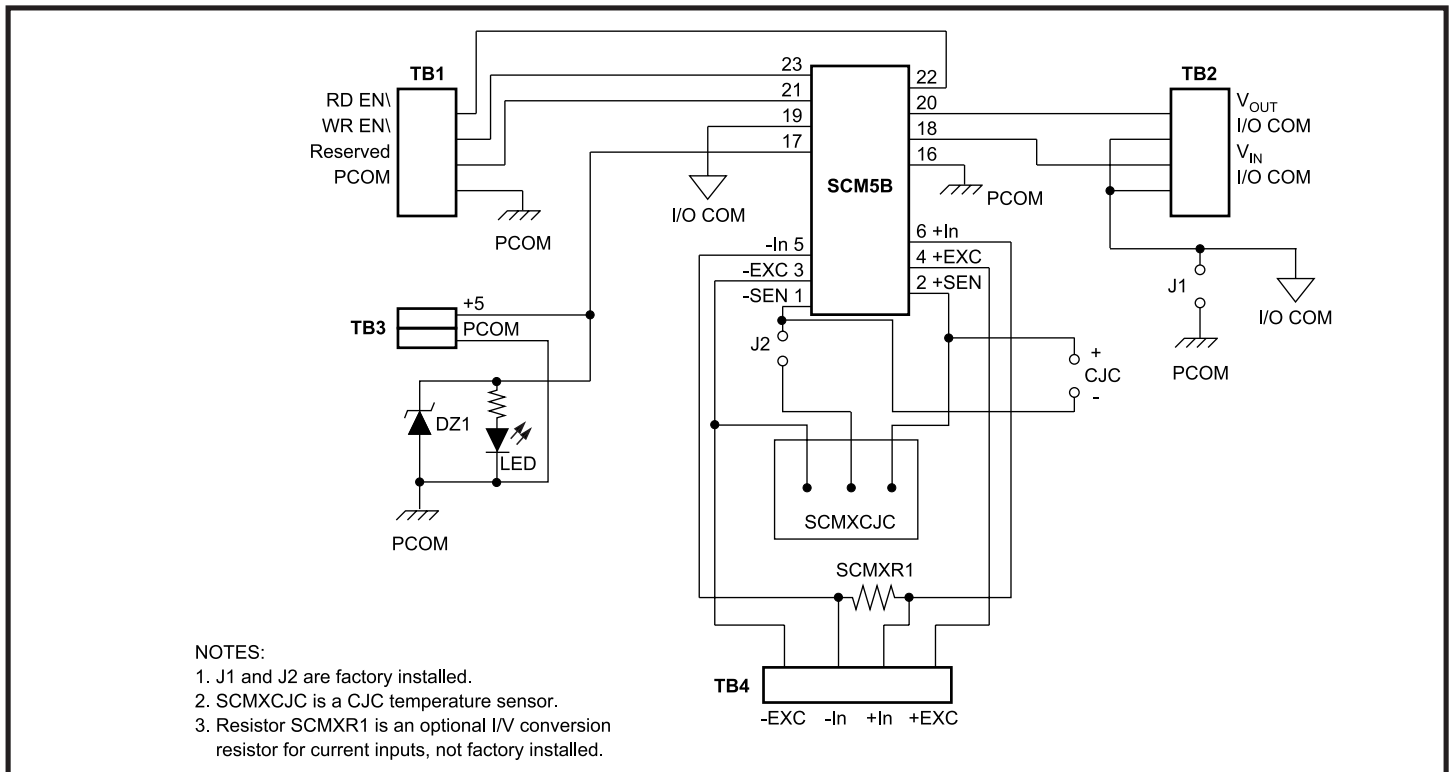

Figure 17: SCMXEV Evaluation Board Dimensions and Pin Layout

If an external simulation voltage is desired for cold junction compensation, J2 should be removed. The external voltage is applied at the sockets labeled CJC+ and CJC-. An external voltage of 510.0mV corresponds to an ambient temperature of +25 °C. The transfer function of the onboard compensation circuit is  $V_{CJC} = 0.510 - 0.0025(T-25)V$ .



- NOTES:
1. J1 and J2 are factory installed.
  2. SCMXCJC is a CJC temperature sensor.
  3. Resistor SCMXR1 is an optional I/V conversion resistor for current inputs, not factory installed.

Figure 18: SCMXEV Evaluation Board Schematic

# SCMXCA004-01, - 02

## Interface Cable

### Description

#### SCMXCA004-XX

System interface cable for the SCMPB01/02/05/06 backpanels. This is a 26 conductor ribbon cable with a mass-terminated socket connector installed on each end. It can be ordered in lengths of 1m and 2m; -xx denotes required length in meters (see Figure 19).

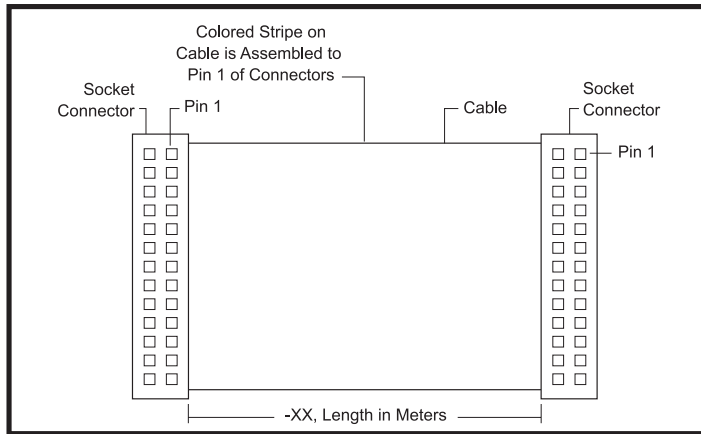

Figure 19: SCMXCA004-XX System Interface Cable

# SCMXIF (-DIN)

## Universal Interface Board

### Description

The SCMXIF is a universal interface board which converts a 26-pin ribbon cable input to 26 screw terminals for discrete wire. It can be mounted on the back of the SCMXRK-002 mounting rack (SCMXIF) or on a DIN rail (SCMXIF-DIN). Required mounting hardware is included. Use SCMXCA004-XX cable (see Figure 20 for dimensions).

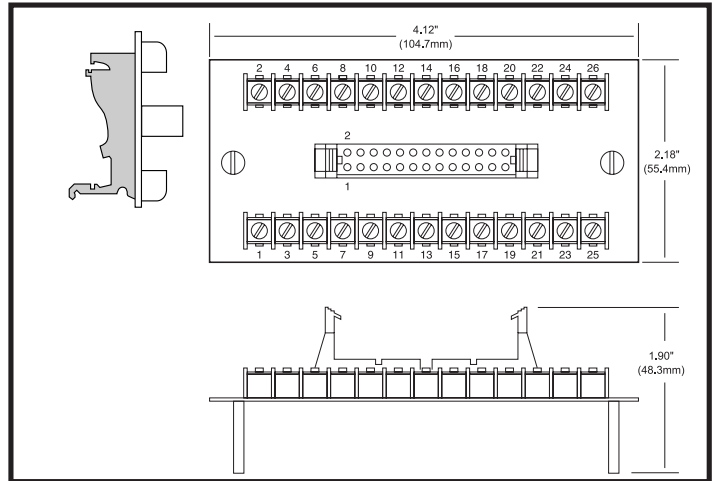

Figure 20: SCMXIF Universal Interface Board Dimensions

# SCMXRK-002

## 19-Inch Metal Mounting Rack

### Description

The SCMXRK-002 is a 19-inch metal rack for mounting the SCMPB01/02/05/06, SCM7BP04/08/16, SCMAS-PB8/16 and isoLynx® SLX200-xx backpanels. It also provides capability to mount the SCMXPRT-001, SCMXPRE-001, SCMXPRT-003 or SCMXPRE-003 power supplies, and the SCMXIF interface board (see Figure 21 for dimensions).

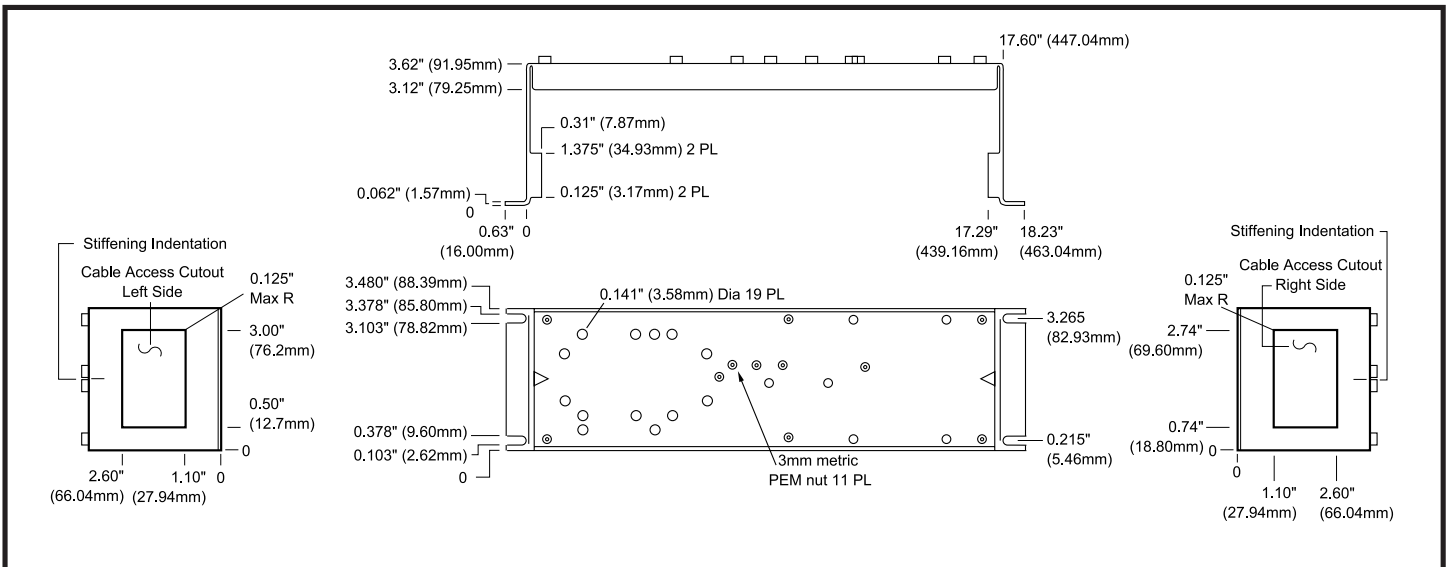

Figure 21: SCMXRK-002 Analog Rack Dimensions

# SCMXCJC

## Encapsulated Cold Junction Compensation

### Description

The SCMXCJC is the identical circuit used on the SCMPB01/02/03/04/05/06/07 backpanels except it is packaged as a component for use in customer designed mounting boards (Figure 22). When interfaced to an SCM5B37 or 47 module the transfer function of the voltage across the +SEN and -SEN pins is  $V_{CJC} = 0.510 - 0.0025(T - 25)V$ .

### Specifications

Accuracy	+25°C	±0.25°C
	+5°C to +45°C	±0.5°C
	-40°C to +85°C	±1.25°C

# SCM5BPT

## Pass Thru Module

### Description

The SCM5BPT is a pass-through module used to establish a direct connection between an input signal and the SCM5B series backplane analog bus. It has unity gain and no isolation. It accepts up to ±10V input and provides up to ±10V output.

# SCM5BPT-1367

## Pass Thru Module with Switch

### Description

The SCM5BPT-1367 is a pass-through module used to establish a direct connection between an input signal and the SCM5B series backplane analog bus. It has unity gain, no isolation, and a logic controlled output switch which allows sharing of a common analog bus with other SCM5B modules. It accepts up to ±10V input and provides up to ±10V output. Resettable fuses and overvoltage protection circuitry protect computer-side electronics.

# SCMXJP-003

## Jumper Strap

### Description

Package of 10 jumpers for connecting adjacent input/output modules on the SCMPB01 backpanel. This connection is made if it is desired to direct the output of any input module to the input of an adjacent output module. The jumpers can also be used for configuring I/O addresses on the SCMPB02 backpanel.

# SCMXFS-003, -004

## Fuse

### Description

Package of 10 fuses for use on the SCMPBxx backpanels. This is a series fuse in the five volt power line. It provides protection against inadvertent reverse connection of five volt power or overvoltage.

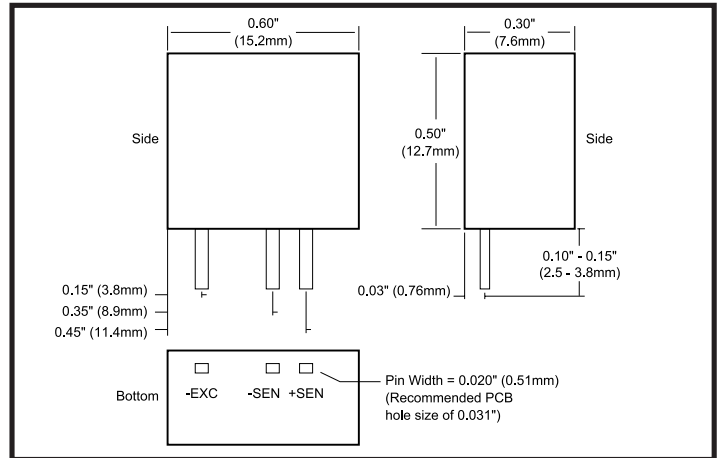

Figure 22: SCMXCJC Physical Dimensions and Pin Layout

# SCMXR1

## Current Conversion Resistor

### Description

A precision 20Ω, 0.1%, 10ppm/°C resistor used with the SCM5B32 current input module or SCM5B42 two-wire transmitter interface module (Figure 23). Sockets are provided on the SCMPB01/02/03/04/05/06/07 and SCMXEV backpanels to allow installation of this resistor. One SCMXR1 is shipped with each SCM5B32 or SCM5B42 module.

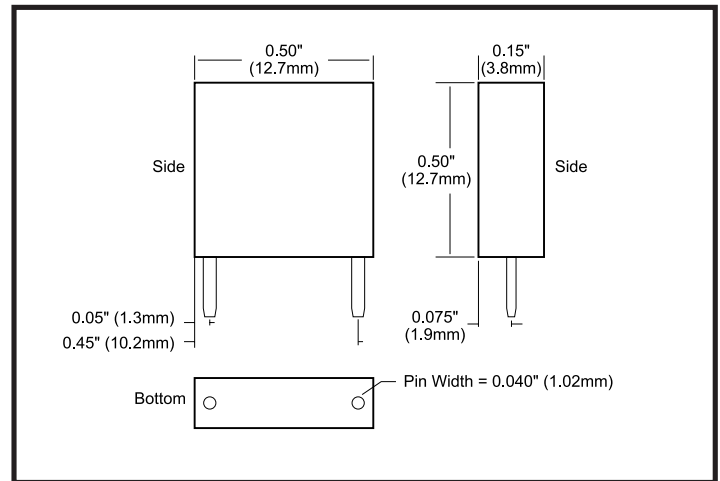

Figure 23: SCMXR1 Physical Dimensions

### Ordering Information

Part Number	Description
SCMXFS-003	4A fuse. Use for SCMPB05/06/07, SCMVAS-PB8, -PB16.
SCMXFS-004	7A fuse. Use for SCMPB01/02.

# SCM5B-PROTO

## Breadboard Kit

### Description

The SCM5B-PROTO breadboard kit was designed to allow users to incorporate their own module functions using an SCM5B format. The kit includes a pc board

designed for breadboard circuits, a module case, header and mounting screw. Contact the factory for additional information.

# SCMXRAIL1-XX, SCMXRAIL2-XX, SCMXRAIL3-XX

## DIN Rail

### Description

Three styles of DIN rail are available. Specify length (-xx) in meters when ordering, -01 for 1 meter or -02 for 2 meter.

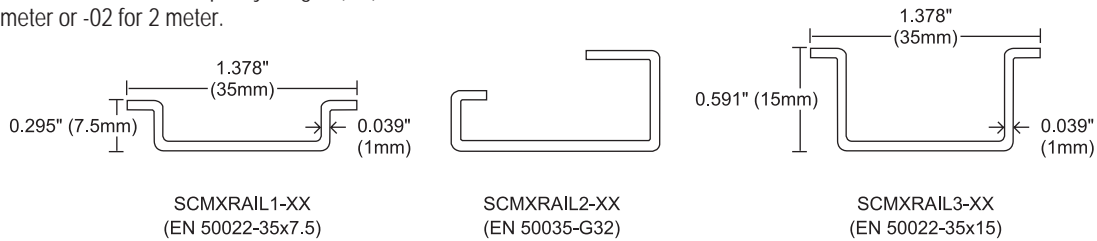

Figure 24: DIN Rail Styles

# SCMXPRT-001/D, SCMXPRE-001/D

## Power Supplies



### Description

The SCMXPRT-001/D and SCMXPRE-001/D encapsulated power supplies are available in 120VAC or 220VAC input voltage ranges and provide 5VDC outputs suitable for all SCM5B modules. They are designed to mount on the SCMXRK-002 metal rack or DIN rail EN 50022-35x7.5 (D versions). The supplies are UL-recognized. Their compact size and low weight are ideal for high-density applications (see Figure 25).

### Specifications Typical\* at T<sub>a</sub>=+25°C

Module	SCMXPRT-001/D	SCMXPRE-001/D
Input Voltage Range, 47Hz to 63Hz	105-125VAC	200-240VAC
Output Voltage	5VDC	5VDC
Output Current, +50°C	1A	1A
	(derate 2.5%/°C above +50°C)	
Operating Temperature	-25°C to +71°C	-25°C to +71°C
Dielectric Withstand V (Input to Ground)	2500Vrms	2500Vrms
Line Regulation	±0.05%	±0.05%
Load Regulation	±0.15%	±0.15%
Output Ripple, max	2mVrms	2mVrms
Overvoltage Protection	6.2V	6.2V
Weight	1.25 lbs (567g)	1.25 lbs (567g)

NOTES:  
 \* Contact factory or your local Dataforth sales office for maximum values.  
 Supplies are UL recognized, File No. E65890.

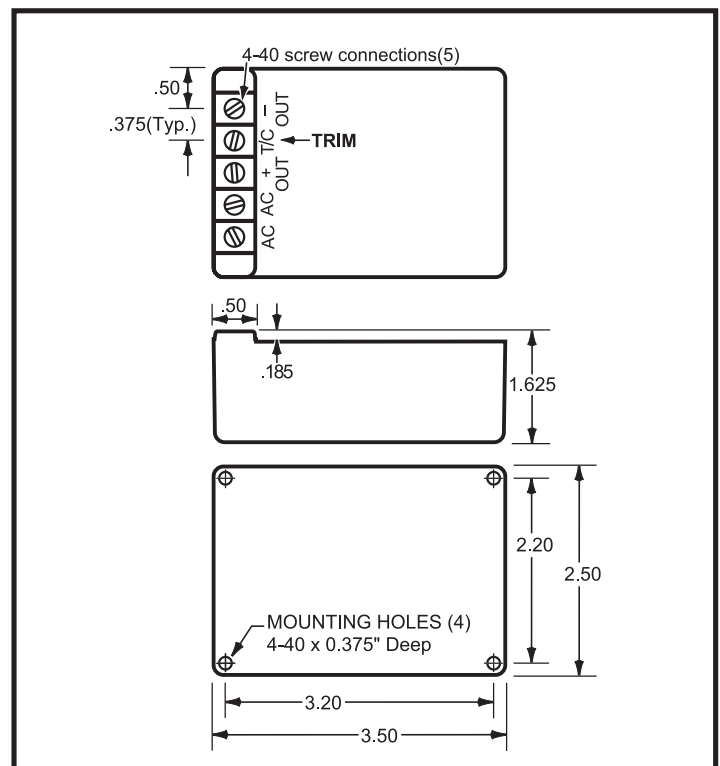

Figure 25: SCMXPRT-001/D and SCMXPRE-001/D Physical Dimensions

# SCMXPRT-003, SCMXPRE-003

## Power Supplies

### Description

The SCMXPRT/E-003 Linear Power Supplies are available in 120VAC or 220VAC input. They have sufficient output current capacity to supply any combination of SCM5B modules. The SCMXRK-002 metal rack provides mounting capability for the SCMXPRT/E-003 power supplies (see Figure 26).

### Specifications Typical\* at T<sub>A</sub>=+25°C

Module	SCMXPRT-003	SCMXPRE-003
Input Voltage Range, 47Hz to 63Hz	104-132VAC	207-265VAC
Output Voltage	5VDC ±1%	5VDC ±1%
Output Current (at +70°C)	3A	3A
Output Current (at +50°C)	6A	6A
Operating Temp	0 to +70°C	0 to +70°C
Dielectric Withstand Voltage (input to ground)	3750VAC	3750VAC
Line Regulation (10% line change)	±0.05%	±0.05%
Load Regulation (50% load change)	±0.05%	±0.05%
Output Ripple (max)	5mVp-p	5mVp-p
Overvoltage Protection (factory set)	6.2V ±0.4V	6.2V ±0.4V

NOTES: \* Contact factory or your local Dataforth sales office for maximum values. Both supplies are tested and certified by TUV to VDE 0806 and IEC 380. They are UL recognized (File Number E55974) and CSA Certified (CSA File Number LR38879).

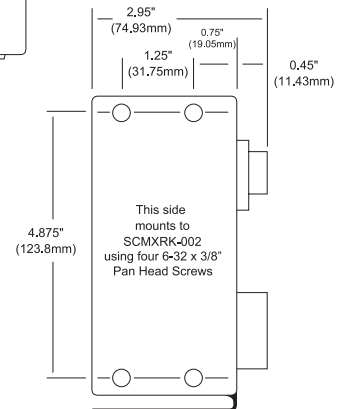
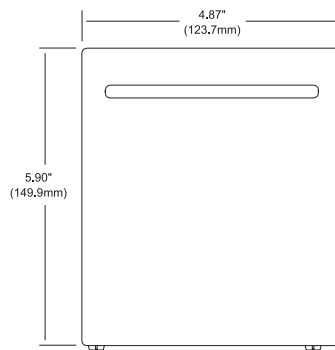

Figure 26: SCMXPRT-003/SCMXPRE-003 Physical Dimensions

# PWR-4505

## 25W Single Output Industrial DIN Rail Switching Power Supply

### Specifications Typical\* at T<sub>A</sub>=+25°C

Input Frequency	85 to 264VAC, 120 to 370VDC
Input Current	47 to 63Hz
Inrush Current	1.5A/115VAC, 0.75A/230VAC
Efficiency	Cold start 30A/115VAC, 60A/230VAC
Output Voltage & Current Rating	72%
Temperature Coefficient	5V, 5A
Ripple Voltage	±0.03%/°C
Overload Protection	100mVp-p
Over Voltage Protection	105 to 150% rated output power
Over Temperature Protection	5.75 to 6.75V
Dielectric Strength	135°C detect on heatsink of power transistor
Insulation Resistance	Between input and output terminals: 3kV, 1 minute
Operating Temperature	Between input and FG: 1.5kV, 1 minute
Storage Temperature	Between output and FG: 0.5kV, 1 minute
Relative Humidity	Between input and output terminals/input and FG/output and FG: 100MΩ/500VDC
Mechanical Dimensions (l)(w)(h)	Operating Temperature: -10°C to +50°C
Terminal Screw	Storage Temperature: -20°C to +85°C
	Relative Humidity: 10 to 95%

NOTES: \* Contact factory or your local Dataforth sales office for maximum values.

### Features

- Universal AC Input (85 to 264VAC)
- DC Compatible Input (120 to 370VDC)
- Protections: Short Circuit, Overload, Over Voltage, Over Temperature
- Mounts on DIN Rail TS-35/7.5 & 15
- Approvals: UL, CUL, TUV, CB, CE
- CE Compliant, UL 508 Listed
- TUV EN60950-1 Approved
- Compliant with EMC Directive EN50082-2
- LED Indicator for Power On

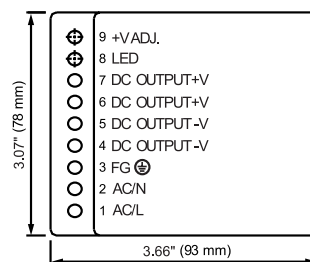

Terminal Pin No. Assignment

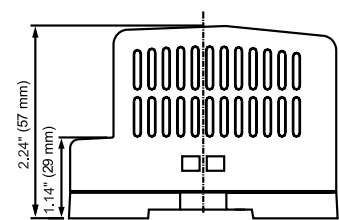

Figure 27 : PWR-4505 Physical Dimensions