

Hikrobot Co., Ltd.

SC5000X Series Smart Camera

Quick Start Guide

HIKROBOT



Presented by: Absolute Gauge Technologies
sales@absolute-gauge.com; www.absolute-gauge.com,
Toronto: 416 754 3168, Montreal: 514 695 5147, Toll Free: 1 888 754 7008

Legal Information

© Hangzhou Hikrobot Co., Ltd. All rights reserved.

About this Document

This Document includes instructions for using and managing the Product. Pictures, charts, images and all other information hereinafter are for description and explanation only. The information contained in the Document is subject to change, without notice, due to firmware updates or other reasons. Please find the latest version in the company website (<https://en.hikrobotics.com/>). Unless otherwise agreed, Hangzhou Hikrobot Co., Ltd. or its affiliates (hereinafter referred to as "Hikrobot") makes no warranties, express or implied. Please use the Document with the guidance and assistance of professionals trained in supporting the Product.

Acknowledgment of Intellectual Property Rights

- Hikrobot owns the copyrights and/or patents related to the technology embodied in the Products described in this Document, which may include licenses obtained from third parties. Any part of the Document, including text, pictures, graphics, etc., belongs to Hikrobot. No part of this Document may be excerpted, copied, translated, or modified in whole or in part by any means without written permission.
- **HIKROBOT** and other Hikrobot's trademarks and logos are the properties of Hikrobot in various jurisdictions. Other trademarks and logos mentioned are the properties of their respective owners.
- **HDMI**[™]: The terms HDMI and HDMI High-Definition Multimedia Interface, and the HDMI Logo are trademarks or registered trademarks of HDMI Licensing Administrator, Inc. in the United States and other countries.

LEGAL DISCLAIMER

TO THE MAXIMUM EXTENT PERMITTED BY APPLICABLE LAW, THIS MANUAL AND THE PRODUCT DESCRIBED, WITH ITS HARDWARE, SOFTWARE AND FIRMWARE, ARE PROVIDED "AS IS" AND "WITH ALL FAULTS AND ERRORS". HIKROBOT MAKES NO WARRANTIES, EXPRESS OR IMPLIED, INCLUDING WITHOUT LIMITATION, MERCHANTABILITY, SATISFACTORY QUALITY, OR FITNESS FOR A PARTICULAR PURPOSE. THE USE OF THE PRODUCT BY YOU IS AT YOUR OWN RISK. IN NO EVENT WILL HIKROBOT BE LIABLE TO YOU FOR ANY SPECIAL, CONSEQUENTIAL, INCIDENTAL, OR INDIRECT DAMAGES, INCLUDING, AMONG OTHERS, DAMAGES FOR LOSS OF BUSINESS PROFITS, BUSINESS INTERRUPTION, OR LOSS OF DATA, CORRUPTION OF SYSTEMS, OR LOSS OF DOCUMENTATION, WHETHER BASED ON BREACH OF CONTRACT, TORT (INCLUDING NEGLIGENCE), PRODUCT LIABILITY, OR OTHERWISE, IN CONNECTION WITH THE USE OF THE PRODUCT, EVEN IF HIKROBOT HAS BEEN ADVISED OF THE POSSIBILITY OF SUCH DAMAGES OR LOSS.

YOU ACKNOWLEDGE THAT THE NATURE OF INTERNET PROVIDES FOR INHERENT SECURITY RISKS, AND HIKROBOT SHALL NOT TAKE ANY RESPONSIBILITIES FOR ABNORMAL OPERATION, PRIVACY LEAKAGE OR OTHER DAMAGES RESULTING FROM CYBER-ATTACK, HACKER ATTACK, VIRUS INFECTION, OR OTHER INTERNET SECURITY

RISKS; HOWEVER, HIKROBOT WILL PROVIDE TIMELY TECHNICAL SUPPORT IF REQUIRED. YOU AGREE TO USE THIS PRODUCT IN COMPLIANCE WITH ALL APPLICABLE LAWS, AND YOU ARE SOLELY RESPONSIBLE FOR ENSURING THAT YOUR USE CONFORMS TO THE APPLICABLE LAW. ESPECIALLY, YOU ARE RESPONSIBLE, FOR USING THIS PRODUCT IN A MANNER THAT DOES NOT INFRINGE ON THE RIGHTS OF THIRD PARTIES, INCLUDING WITHOUT LIMITATION, RIGHTS OF PUBLICITY, INTELLECTUAL PROPERTY RIGHTS, OR DATA PROTECTION AND OTHER PRIVACY RIGHTS. YOU SHALL NOT USE THIS PRODUCT FOR ANY PROHIBITED END-USES, INCLUDING THE DEVELOPMENT OR PRODUCTION OF WEAPONS OF MASS DESTRUCTION, THE DEVELOPMENT OR PRODUCTION OF CHEMICAL OR BIOLOGICAL WEAPONS, ANY ACTIVITIES IN THE CONTEXT RELATED TO ANY NUCLEAR EXPLOSIVE OR UNSAFE NUCLEAR FUEL-CYCLE, OR IN SUPPORT OF HUMAN RIGHTS ABUSES.

THE PERFORMANCE DATA IN THIS PUBLICATION IS BASED ON HIKROBOT'S INTERNAL RESEARCH/EVALUATION. ACTUAL DATA MAY VARY DEPENDING ON SPECIFIC CONFIGURATIONS AND OPERATING CONDITIONS AND HIKROBOT SHALL NOT BEAR THE CONSEQUENCES ARISING THEREFROM.

IN THE EVENT OF ANY CONFLICTS BETWEEN THIS MANUAL AND THE APPLICABLE LAW, THE LATTER PREVAILS.

Regulatory Information

Note

- These clauses apply only to the products bearing the corresponding mark or information.
 - Due to the product shape and dimension, the name and address of the importer/manufacture are printed on the package.
-

EU Conformity Statement



This product and - if applicable - the supplied accessories too are marked with "CE" and comply therefore with the applicable harmonized European standards listed under the Directive 2014/30/EU(EMCD), Directive 2001/95/EC(GPSD) and Directive 2011/65/EU(RoHS).



2012/19/EU (WEEE directive): Products marked with this symbol cannot be disposed of as unsorted municipal waste in the European Union. For proper recycling, return this product to your local supplier upon the purchase of equivalent new equipment, or dispose of it at designated collection points. For more information see: <http://www.recyclethis.info>



Regulation (EU) 2023/1542(Battery Regulation): This product contains a battery and it is in conformity with the Regulation (EU) 2023/1542. The battery cannot be disposed of as unsorted municipal waste in the European Union. See the product documentation for specific battery information. The battery is marked with this symbol, which may include

lettering to indicate cadmium (Cd), or lead (Pb). For proper recycling, return the battery to your supplier or to a designated collection point. For more information see: www.recyclethis.info.

This is a class A product. In a domestic environment this product may cause radio interference in which case the user may be required to take adequate measures.



KC Mark Certification

Class A: The device is advised to note that as a seller or a business user (Class A) Devices and intended for use outside the Home area.

A급 기기: 이 기기는 업무용(A급) 전자파적합기기로서 판매자 또는 사용자는 이 점을 주의하시기바라며, 가정 외의 지역에서 사용하는 것을 목적으로 합니다.

Symbol Conventions

The symbols that may be found in this document are defined as follows.

Symbol	Description
 Danger	Indicates a hazard with a high level of risk, which if not avoided, will result in death or serious injury.
 Caution	Indicates a potentially hazardous situation which, if not avoided, could result in equipment damage, data loss, performance degradation, or unexpected results.
 Note	Provides additional information to emphasize or supplement important points of the main text.

Available Model

This manual is applicable to the SC5000X Series Smart Camera.

Contact Information

Hangzhou Hikrobot Co., Ltd.

E-mail: global.support@hikrobotics.com

Website: <https://en.hikrobotics.com/>

Contents

Chapter 1 Safety Instruction	1
1.1 Safety Claim.....	1
1.2 Safety Instruction.....	1
1.3 Electromagnetic Interference Prevention.....	3
Chapter 2 Overview	4
2.1 Introduction.....	4
2.2 Key Features.....	4
Chapter 3 Appearance	5
Chapter 4 12-Pin M12 Connector	9
Chapter 5 Device Installation and Wiring	11
5.1 Installation Preparation.....	11
5.1.1 Included Accessories.....	11
5.1.2 Required Accessories.....	12
5.1.3 Optional Accessories.....	12
5.2 Install Device.....	13
5.3 Wire Device.....	15
Chapter 6 Device Operation	17
6.1 Client Software Introduction.....	17
6.2 Install Client Software.....	17
6.3 Create and Run Solution.....	18
Chapter 7 I/O and Serial Port	19
7.1 I/O Electrical Feature.....	19
7.1.1 Internal Circuit of Input Signal.....	19
7.1.2 Internal Circuit of Output Signal.....	20
7.2 I/O Wiring.....	21
7.2.1 Input Signal Wiring.....	21
7.2.2 Output Signal Wiring.....	22
7.3 RS-232 Serial Port.....	24
Chapter 8 FAQ (Frequently Asked Question)	25
8.1 Why there is no device listed after I run the client software?.....	25
8.2 Why the image is very dark?.....	25
8.3 Why the image's frame rate is very low in the live view?.....	25
8.4 Why there is no image in the live view?.....	25

Chapter 1 Safety Instruction

The safety instructions are intended to ensure that the user can use the device correctly to avoid danger or property loss. Read and follow these safety instructions before installing, operating and maintaining the device.

1.1 Safety Claim

- To ensure personal and device safety, when installing, operating, and maintaining the device, follow the signs on the device and all safety instructions described in the manual.
- The note, caution and danger items in the manual do not represent all the safety instructions that should be observed, but only serve as a supplement to all the safety instructions.
- The device should be used in an environment that meets the design specifications, otherwise it may cause malfunctions, and malfunctions or component damage caused by non-compliance with relevant regulations are not within the scope of the device's quality assurance.
- Our company will not bear any legal responsibility for personal safety accidents and property losses caused by abnormal operation of the device.

1.2 Safety Instruction



Caution

- Do not install the device if it is found that the device and accessories are damaged, rusted, water ingress, model mismatch, missing parts, etc., when unpacking.
- Avoid storage and transportation in places such as water splashing and rain, direct sunlight, strong electric fields, strong magnetic fields, and strong vibrations.
- Avoid dropping, smashing or vigorously vibrating the device and its components.
- It is forbidden to install the indoor device in an environment where it may be exposed to water or other liquids. If the device is damp, it may cause fire and electric shock hazard.
- Place the device in a place out of direct sunlight and ventilation, away from heat sources such as heaters and radiators.
- This is a class A product. In a domestic environment this product may cause radio interference in which case the user may be required to take adequate measures.
- In the use of the device, you must be in strict compliance with the electrical safety regulations of the nation and region.
- Do not connect multiple devices to the same power adapter. Exceeding the adapter load may cause a fire due to excessive heat generation.
- Use the power adapter provided by the official manufacturer. The power adapter must meet the Limited Power Source (LPS) requirements. For specific requirements, please refer to the device's technical specifications.

SC5000X Series Smart Camera Quick Start Guide

- It is strictly forbidden to wire, maintain, and disassemble the device is powered on. Otherwise, there is a danger of electric shock.
- Before powering on the device, please confirm that the device is installed in good condition, the wiring is firm, and the power supply meets the requirements.
- If the device emits smoke, odor or noise, please turn off the power and unplug the power cord immediately, and contact the dealer or service center in time.
- It is strictly forbidden to touch any terminal of the device when operating it. Otherwise there is a danger of electric shock.
- It is strictly forbidden for non-professional technicians to detect signals during device operation, otherwise it may cause personal injury or device damage.
- It is strictly forbidden to maintain the device is powered on, otherwise there is a danger of electric shock.
- This device has a retinal blue light hazard. Do not observe the light source during the operation. Protective measures like wearing safety goggles are required when installing, maintaining and debugging the device.
- Avoid aiming the image sensor at strong light in direct mode or reflection mode, such as laser beams, otherwise the image sensor will be damaged.
- If the device does not work properly, please contact your dealer or the nearest service center. Never attempt to disassemble the device yourself. We shall not assume any responsibility for problems caused by unauthorized repair or maintenance.
- Please dispose of the device in strict accordance with the relevant national or regional regulations and standards to avoid environmental pollution and property damage.

Note

- Check whether the device's package is in good condition, whether there is damage, intrusion, moisture, deformation, etc. before unpacking.
- Check the surface of the device and accessories for damage, rust, bumps, etc. when unpacking.
- Check whether the quantity and information of the device and accessories are complete after unpacking.
- Store and transport the device according to the storage and transport conditions of the device, and the storage temperature and humidity should meet the requirements.
- It is strictly prohibited to transport the device in combination with items that may affect or damage the device.
- The device should not be placed with exposed flame sources, such as lighted candles.
- Please read the manual and safety instructions carefully before installing the device.
- Quality requirements for installation and maintenance personnel:
 - Qualification certificate or working experience in weak current system installation and maintenance, and relevant working experience and qualifications. Besides, the personnel must possess the following knowledge and operation skills.
 - The basic knowledge and operation skills of low voltage wiring and low voltage electronic circuit connection.
 - The ability to comprehend the contents of this manual.

1.3 Electromagnetic Interference Prevention

- Make sure that the shielding layer of cables is intact and 360° connected to the metal connector when using shielded cables.
- Do not route the device together with other equipment (especially servo motors, high-power devices, etc.), and control the distance between cables to more than 10 cm. Make sure to shield the cables if unavoidable.
- The control cable of the device and the power cable of the industrial light source must be wired separately to avoid bundled wiring.
- The power cable, data cable, signal cable, etc. of the device must be wired separately. Make sure to ground them if the wiring groove is used to separate the wiring and the wiring groove is metal.
- During the wiring process, evaluate the wiring space reasonably, and do not pull the cables hard, so as not to damage the electrical performance of the cables.
- If the device is powered on and off frequently, it is necessary to strengthen the voltage isolation, and consider adding a DC/DC isolation power supply module between the device and the adapter.
- Use the power adapter to supply power to the device separately. If centralized power supply is necessary, make sure to use a DC filter to filter the power supply of the device separately before use.
- The unused cables of the device must be insulated.
- When installing the device, if you cannot ensure that the device itself and all equipment connected to the device are well grounded, you should isolate the device with an insulating bracket.
- To avoid the accumulation of static electricity, ensure that other equipment (such as machines, internal components, etc.) and metal brackets on site are properly grounded.
- During the installation and use of the device, high voltage leakage must be avoided.
- Use a figure-eight bundle method if the device cable is too long.
- When connecting the device and metal accessories, they must be connected firmly to maintain good conductivity.

Chapter 2 Overview

2.1 Introduction

The SC5000X series smart camera is developed based on high-performance embedded platform, integrating Gigabit Ethernet interface, Type-C interface, and serial port, which is convenient for accessing to complex vision system. It integrates the Vision Master Algorithm Development Platform, which supports running the solution directly on the camera after connecting to the monitor, instead of the industrial PC. The camera supports a variety of AI deep learning algorithms with powerful computing performance, and can meet the requirements of OCR, object recognition, defect detection, and other visual inspection. The SC5000X series smart camera is applicable to the consumer electronics, food and pharmaceutical, packaging industry, etc.

2.2 Key Features

- Adopts AI deep learning algorithm to achieve OCR, object recognition, defect detection, etc.
- Integrates Vision Master Algorithm Development Platform and supports more than 140 algorithms.
- Adopts multiple I/O interfaces, such as multiple input/output signals.
- Supports multiple communication protocols.
- Supports indicators displaying device status for easy debugging and maintenance.
- Supports ingress protection IP67.

Note

- The specific functions may differ by device models.
 - Refer to the device's datasheet for specific parameters.
-

Chapter 3 Appearance

 **Note**

Appearance here is for reference only. Refer to the device's datasheet for detailed dimension information.

The SC5000X series smart camera currently has two types of devices. Refer to the table below for detailed relation between device types and models.

Table 3-1 Device Types and Models

No.	Device Type	Device Model	Appearance
1	M12-Mount Device	<ul style="list-style-type: none"> ● MV-SC5020XC ● MV-SC5020XM ● MV-SC5050XC ● MV-SC5050XM 	Figure 3-1
2	C-Mount Device	<ul style="list-style-type: none"> ● MV-SC5020XC-00C ● MV-SC5020XM-00C ● MV-SC5050XC-00C ● MV-SC5050XM-00C ● MV-SC5120XC-00C ● MV-SC5120XM-00C 	Figure 3-2

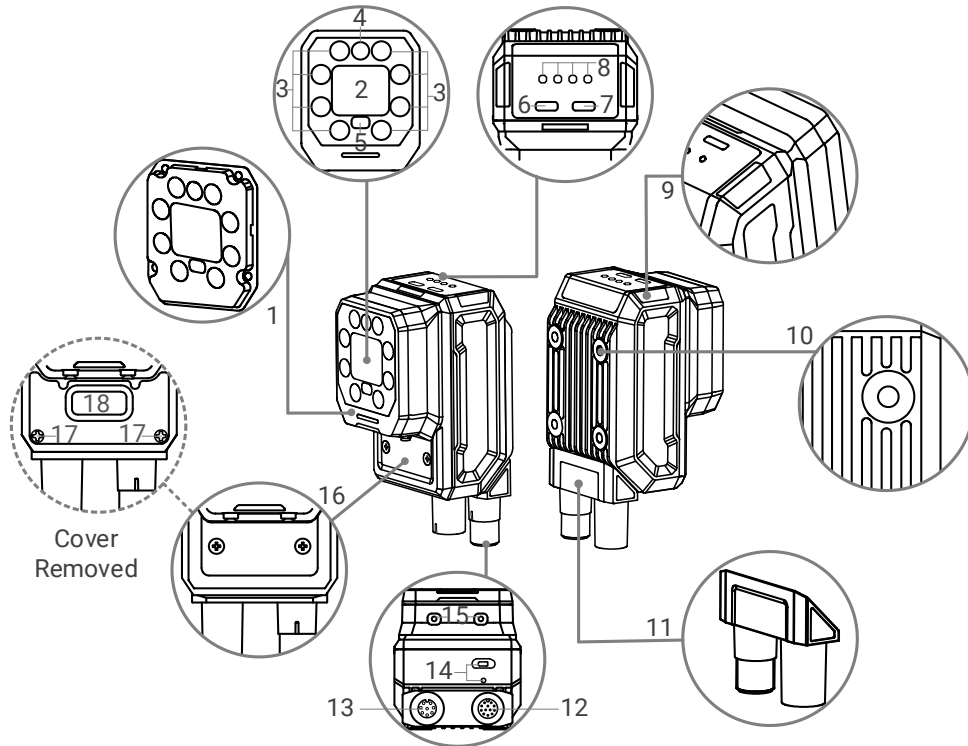

Figure 3-1 M12-Mount Device Appearance

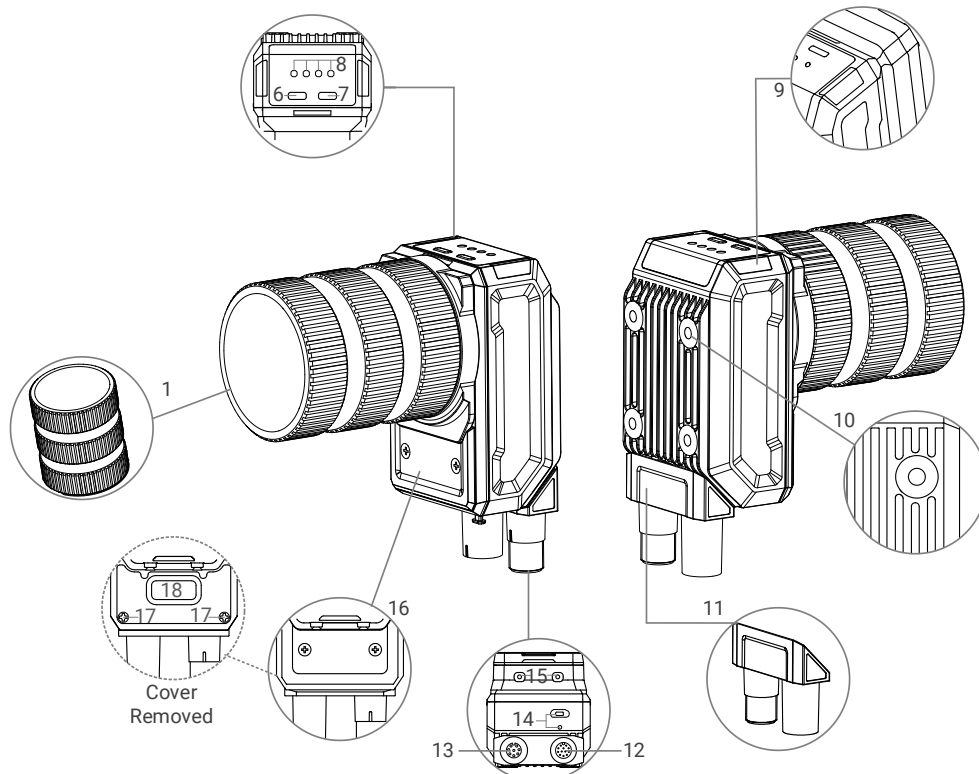









Figure 3-2 C-Mount Device Appearance

Table 3-2 Component Description

No.	Name	Description
1	Lens Cap	M12-mount device adopts half polarization lens cap and C-mount device adopts transparent lens cap.  Note Lens cap of M12-mount device can be replaced with other lens cap according to actual demand. For more details, refer to section Optional Accessories .
2	Acquisition Module	It is used to acquire image data.
3	Light Source	It refers to 8 white LED lamps, which provides light for improving image quality.  Note It is only supported by M12-mount device, and the default color of LED lamps is white. Light source color is decided by light board, and red, blue, and IR light of light boards are optional. For more details, refer to section Optional Accessories .
4	Aiming System	It is orange LED light used to show the field of view and aim targets.  Note It is only supported by M12-mount device.
5	TOF	It is used to detect the position of targets, and realize focus and image parameter adjustment.  Note It is only supported by M12-mount device.
6	Param Adjust Button	After you press the button, the camera will automatically execute parameter adjustment according to the current image environment. Parameters include focal length, exposure, and gain.
7	Trigger Button	It is used to trigger the device via pressing the button. If the device is in trigger mode, press the button and the device triggers once.
8	Device Indicator (Top)	It includes power indicator (PWR), network indicator (LNK), and user-defined indicator (U1/U2). <ul style="list-style-type: none"> ● Power indicator (PWR): The power indicator is solid blue when the device operates normally. ● Network indicator (LNK): The network indicator is solid orange when the network transmission is normal. ● User-defined indicator (U1/U2): The device has 2 user-

SC5000X Series Smart Camera Quick Start Guide

No.	Name	Description
		defined indicators, U1 and U2. They are solid red or solid blue, and used to indicate whether some functions of the device are normal or not.
9	Status Indicator (Both Sides)	The status indicators show the status of the VM service. They are solid green when the VM service is running normally, or solid red when an exception occurs in the VM service.
10	Screw Hole (Back Side)	It is used to fix the device, and you should use the M4 screws.
11	Right Angle Rotation Structure	It is used to rotate the device's cables.
12	Power and I/O Connector	It provides power, I/O, and serial port signal.
13	Network Interface	It is the fast Ethernet for transmitting data.
14	Type-C Interface	It is used to connect to the monitor, keyboard, and mouse via the Type-C cable. There is a screw hole next to the interface to fix the Type-C cable.  Note <ul style="list-style-type: none"> • You should purchase the Type-C cable from our company. Because this interface is a non-standard Type-C interface. • This interface does not support hot plugging.
15	Screw Hole (Bottom Side)	It is used to connect to the protective cover, and you should use the M2 screws.  Note You should purchase the protective cover from our company.
16	Extended Interface Cover	Loosen the two screws to remove the cover, and you can connect to the flash light source via the interface.
17	Light Source Screw Hole	It is used to fix the flash light source, and you should use the M2.5 screws.
18	Flash Light Source Interface	It is used to connect to the flash light source.  Note You should purchase the flash light source from our company.

Chapter 4 12-Pin M12 Connector

Read the following content to get pin definitions of 12-pin M12 connector.

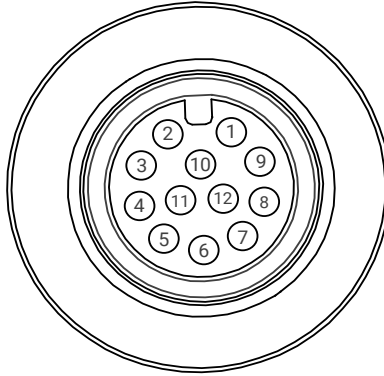













Figure 4-1 12-Pin M12 Connector

Table 4-1 Pin Definitions

No.	Signal	I/O Signal Source	Description	Cable Color	
1	DC-PWR	--	Direct current power supply positive	White	
2	GND	--	Power supply ground	Brown	
3	OPTO_OUT3	Line 3	Opto-isolated output 3	Green	
4	OPTO_OUT4	Line 4	Opto-isolated output 4	Yellow	
5	OPTO_OUT5	Line 5	Opto-isolated output 5	Gray	
6	OUT_COM	Line 3/4/5 signal ground	Opto-isolated output common port	Pink	
7	OPTO_IN0	Line 0	Opto-isolated input 0	Blue	
8	OPTO_IN1	Line 1	Opto-isolated input 1	Red	
9	OPTO_IN2	Line 2	Opto-isolated input 2	Black	
10	IN_COM	Line 0/1/2 signal ground	Opto-isolated input common port	Purple	
11	RS-232_R	--	RS-232 serial port input	Gray/Pink	
12	RS-232_T	--	RS-232 serial port output	Red/Blue	

Note

- You should refer to the table above and the label attached to the supplied power and I/O cable to wire the device.

SC5000X Series Smart Camera Quick Start Guide

- The cable colors mentioned above are applicable to the 12-pin M12 I/O cable sold by our company.
 - The I/O signal source mentioned in the table above corresponds to the information in **Camera Management** → **I/O Options** in VM client software. Refer to section **Client Software Introduction** and user manual of the VM client for details.
-

Chapter 5 Device Installation and Wiring

5.1 Installation Preparation

You should prepare following accessories before device installation. Make sure the device in the package is in good condition and all the assembly parts are included, and you need to purchase the required accessories and optional accessories according to actual demands.







 **Note**

The images here are for reference only. Please refer to the actual device.

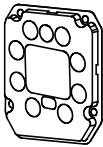
5.1.1 Included Accessories

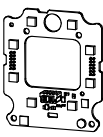
The included accessories are in the device's package, as shown in the table below.

Table 5-1 Included Accessories

No.	Name	Image	Quantity	Description
1	M4 Screw	\	4	It is used to fix the device. For more details, refer to section Install Device .
2	Installation Bracket		1	It is used to fix the device. For more details, refer to section Install Device .
3	Lens Cap (M12-Mount Device)		1	It refers to half polarization lens cap for M12-mount device, and can be replaced with other lens cap according to actual demand.  Note It is not supported by C-mount device.
4	Light Board (M12-Mount Device)		1	It refers to the white light board for M12-mount device, and can be replaced with other light board according to actual demand.  Note It is not supported by C-mount device.
5	Lens Cap (C-Mount Device)		1	It refers to transparent lens cap for C-mount device.  Note It is not supported by M12-mount device.

5.1.2 Required Accessories

You need to purchase the required accessories separately, as shown in the table below.

Table 5-2 Required Accessories

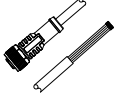
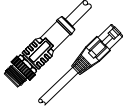
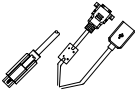
No.	Name	Image	Quantity	Description
1	Power and I/O Cable		1	It refers to the 12-pin M12 to open I/O cable. You should purchase it from our company.
2	M12 Network Cable		1	It refers to the 8-pin M12 to RJ45 network cable. You should purchase it from our company.
3	Type-C Adapter Cable		1	It refers to the Type-C adapter cable with HDMI interface and USB interface, and is used to connect to the monitor, mouse, or keyboard. You should purchase it from our company.
4	M6 Screw	\	2	The M6 screws are used to fix the installation bracket to the specified location.
5	Power Adapter	\	1	You can select a suitable power adapter or switch power supply according to the device power supply and consumption in the specification.
6	Lens (C-Mount Device)	\	1	It is not included in the package of C-mount device, and you should purchase separately.

5.1.3 Optional Accessories

You need to purchase the optional accessories for M12-mount and C-mount devices based on actual demand, as shown in the tables below.

Table 5-3 Optional Accessories for M12-Mount Device

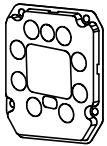
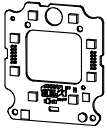
No.	Name	Image	Description
1	Lens Cap		M12-mount device adopts half polarization lens cap by default, and can be replaced with transparent or polarization lens cap according to actual demand.
2	Light Board		M12-mount device adopts white light board by default, and can be replaced with red/blue/IR light board according to actual demand.



No.	Name	Image	Description
3	ESD Protective Cover		It is used to achieve ESD protection for M12-mount device.
4	Multi-Color Light Source		M12-mount device adopts white light by default (single color). For the demand of other colors, you can purchase multi-color light source, which provides white, red, blue, and green light, to meet the requirements of different backgrounds for code reading.
5	Flash Light Source		M12-mount device adopts white light by default. For the demand of requirements of scene with far distance, wide field of view, or high reflectivity, you can purchase the flash light source. You can install the flash light source after removing the extended interface cover, and then use the M2.5 screws to fix it.

Table 5-4 Optional Accessories for C-Mount Device

No.	Name	Image	Description
1	Flash Light Source		C-mount device does not adopt light source by default. For the demand of requirements of scene with far distance, wide field of view, or high reflectivity, you can purchase the flash light source. You can install the flash light source after removing the extended interface cover, and then use the M2.5 screws to fix it.
2	Other Light Source	\	C-mount device does not adopt light source by default. For the demand of light filling, you can purchase other light source.  Note It should be light source with SMR-03V-B interface and constant voltage.

5.2 Install Device

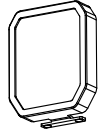
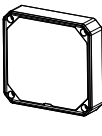
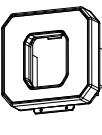
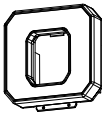
Here we take M12-mount device as an example to introduce the device installation, and appearance here is for reference only.

Before You Start

- Make sure the device in the package is in good condition and all the assembly parts are included.

- Make sure that all the related devices are powered off during the installation.

Steps

1. Select a suitable installation location according to the device's field of view.

Note

Refer to the device's specifications for detection range.

2. Adjust the device's right angle rotation structure according to the installation location.

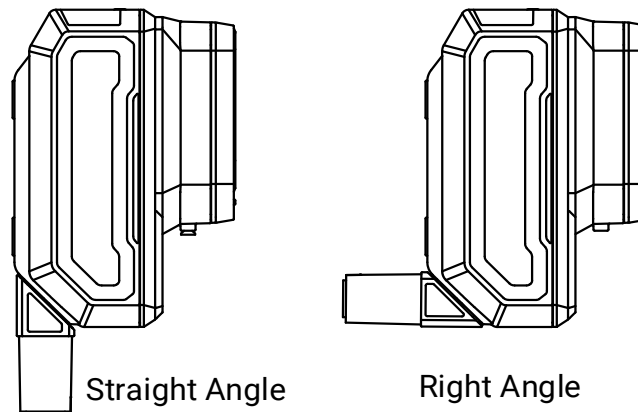

Figure 5-1 Adjust Right Angle Rotation Structure

Note

Refer to the device's specifications for the dimension of the right angle rotation structure.

3. Use M4 screws to fix the installation bracket to the device, as shown below.

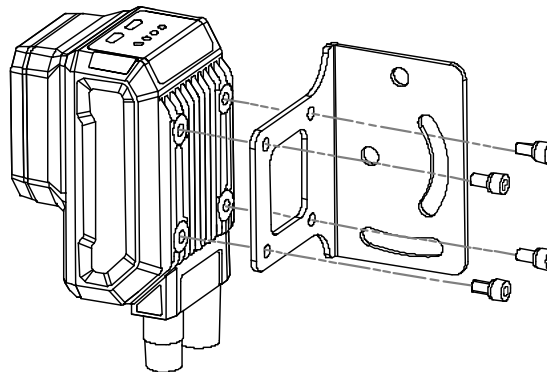

Figure 5-2 Fix Installation Bracket

4. Install the device to the installation location via the M6 screws.

5.3 Wire Device

Here we take M12-mount device as an example to introduce the device wiring, and appearance here is for reference only.

After installing the device, you should use the power and I/O cable, network cable, and Type-C adapter cable to wire and power the device.

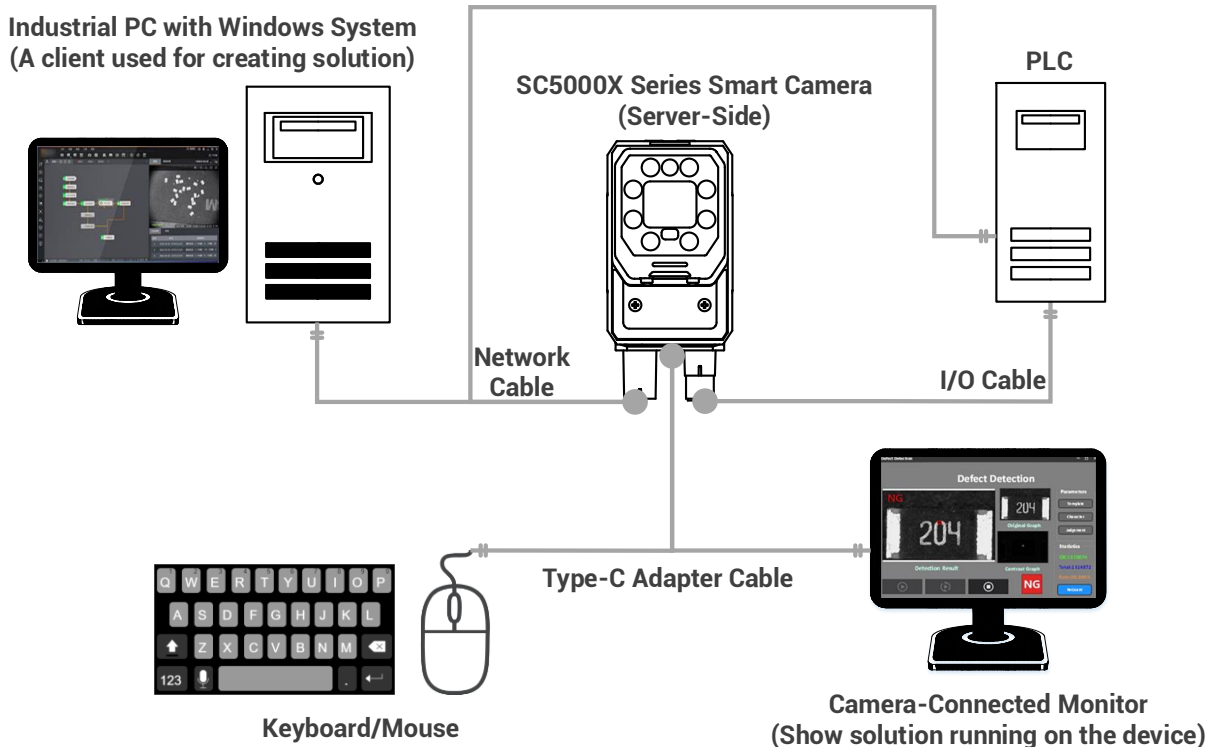

Figure 5-3 Device Connection

Steps

1. Use the 8-pin M12 network cable to connect the device's network interface.

Note

The connector has screw thread, and it is recommended to tighten the connector before using the device to reduce looseness due to the vibration on-site.

2. Insert the RJ45 port of the network cable to the PC.
3. Use the power and I/O cable to connect the device's 12-pin connector.

Note

The connector has screw thread, and it is recommended to tighten the connector before using the device to reduce looseness due to the vibration on-site.

4. Select a suitable power adapter to connect the open cables of the supplied power and I/O cable for power supply.

Note

- The device's indicator is in blue color after the device is powered on.
 - Refer to the section **12-Pin M12 Connector** for specific cable color of open lines.
-

5. Connect the HDMI interface, one end of the Type-C adapter cable, to the monitor, and connect the USB interface, the other end of the Type-C adapter cable, to the mouse or keyboard.
-

Note

There are screws next to the Type-C interface. When connecting the Type-C interface to the device, you should tighten the screws into the screw hole to reduce looseness due to the vibration on-site.

Chapter 6 Device Operation

Before operating on the device, you need to execute debugging via client software, create and run the vision solutions.

6.1 Client Software Introduction

Table 6-1 Client Software Description

No.	Client Software	Installation Method	Description
1	VM Service	Auto installation: It has been installed in the Linux-ARM system by default.	It provides the service for VM client.
2	VM Client-ARM	Auto installation: It has been installed in the Linux-ARM system by default.	It refers to the VM client with Linux-ARM system, and is used to execute solution running and debugging.
3	VM Client	Manual installation: You can contact technical support to get the installation package.	It refers to the VM client with Windows system, and is used to execute parameter debugging, solution creation and debugging.
4	VisionTrain	Manual installation: You can get the installation package from Download Center of https://en.hikrobotics.com/ .	It is a software that can be used for generating deep learning training models, which provides data related to deep learning for the VM client.

6.2 Install Client Software

You can contact technical support to get the installation package of the VM client, and install on the industrial PC or computer with Windows system.

Steps

1. Double-click the installation package to start installing the client software.



Figure 6-1 Installation Interface

2. Read and check **Read and Accept the LICENSE**, and click **Next**.
3. Select installation directory, and click **Next**.
4. Finish the installation according to the interface prompts.

Note

You can refer to the installation guide in the installation package for more information.

6.3 Create and Run Solution

After installation, you can log in to the client, create and run the solution on the client.

Note

You can click **Help** to get the **Vision Master Platform User Manual** for more information.

Steps

1. Double-click the client software to run it.
2. In the **Device Address** page, select the device as needed. You can enter the IP address of the device to connect, or you can click the triangle icon in the lower-right corner of the input box to select the device enumerated by the VM Platform that is on the same local network.
3. Set and confirm the connection password, and click **Verify**.
4. Click **Confirm** to set the device as the VM Server.
5. In the welcome page, select and run a solution.

Chapter 7 I/O and Serial Port

The device has three opto-isolated input signals and three opto-isolated output signals.

7.1 I/O Electrical Feature

7.1.1 Internal Circuit of Input Signal

The device's Line 0/1/2 is opto-isolated input, and their internal circuit is as follows.

Note

- The input voltage ranges from 5 VDC to 30 VDC.
- The breakdown voltage is 36 VDC. Keep voltage stable.

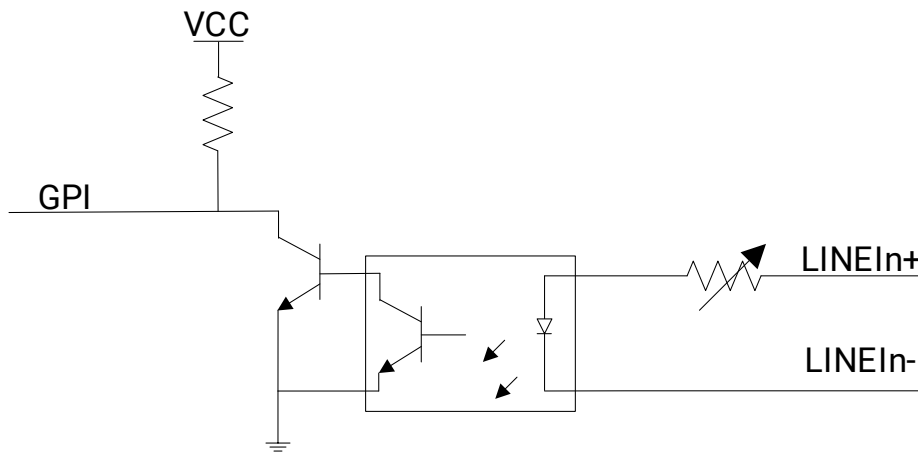

Figure 7-1 Internal Circuit of Input Signal

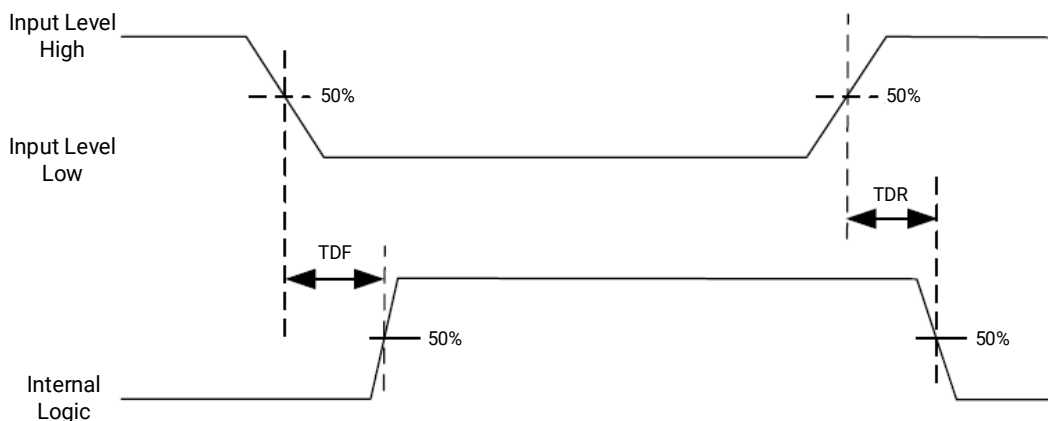

Figure 7-2 Input Logic Level

Table 7-1 Input Electrical Feature

Parameter Name	Parameter Symbol	Value
Input Logic Level Low	VL	1.5 VDC
Input Logic Level High	VH	2 VDC
Input Falling Delay	TDF	81.6 μ s
Input Rising Delay	TDR	7 μ s

7.1.2 Internal Circuit of Output Signal

The device's Line 3/4/5 is opto-isolated output, and their internal circuit is as follows.

Note

- The output voltage ranges from 5 VDC to 30 VDC.
- The maximum current is 45 mA.
- Do not directly connect with inductive load (e.g. DC motor, etc.) when outputting.

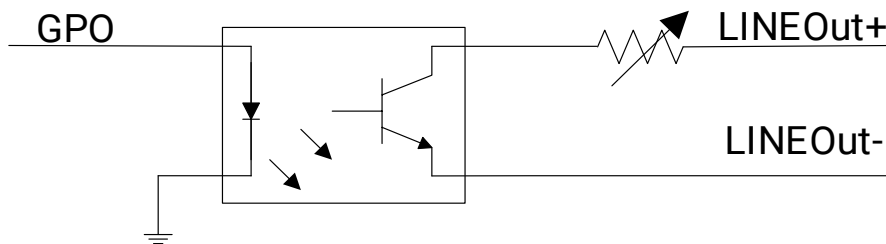

Figure 7-3 Internal Circuit of Output Signal

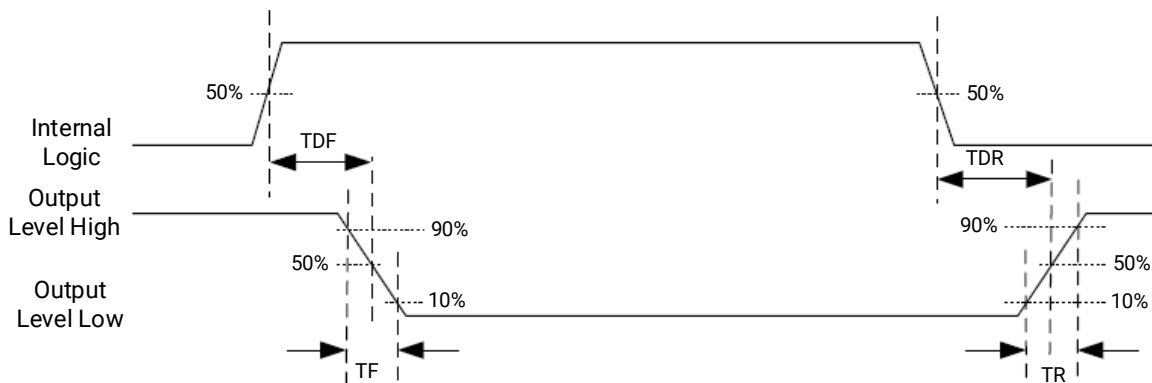

Figure 7-4 Output Logic Level

Note

If the external voltage and resistance change, the corresponding current of output signal and output logic level low may differ.

Table 7-2 Output Electrical Feature

Parameter Name	Parameter Symbol	Value
Output Logic Level Low	VL	730 mV
Output Logic Level High	VH	3.2 VDC
Output Falling Delay	TDF	6.3 μ s
Output Rising Delay	TDR	68 μ s
Output Falling Time	TF	3 μ s
Output Rising Time	TR	60 μ s

7.2 I/O Wiring

7.2.1 Input Signal Wiring

The device can receive external input signal via I/O interface, and here we take Line 0 as an example to introduce input signal wiring.

Note

- Input signal wiring may differ by different types of external devices.
- The voltage of VCC from NPN device should be set as 12VDC or 24VDC according to the actual demand.

Input Signal from PNP Device

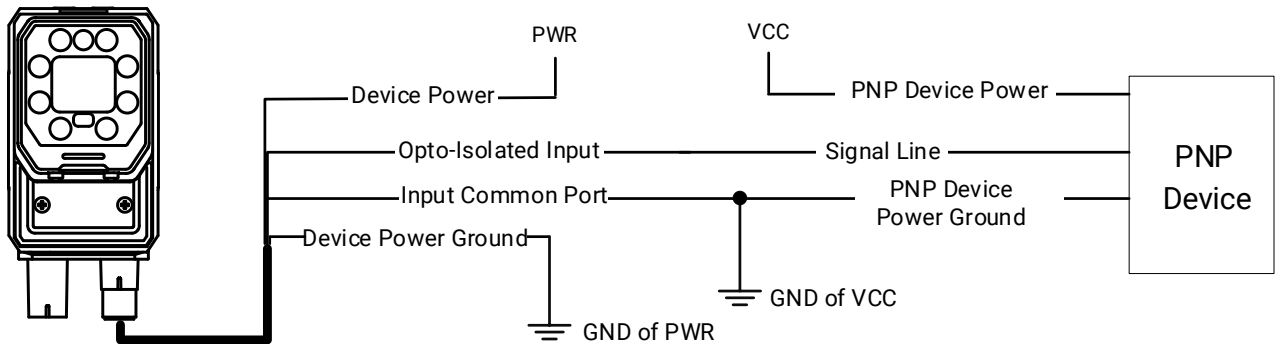

Figure 7-5 Input Signal Connecting to a PNP Device

Input Signal from NPN Device

It is recommended to use a 1 K Ω pull-up resistor, and you can refer to the wiring below.

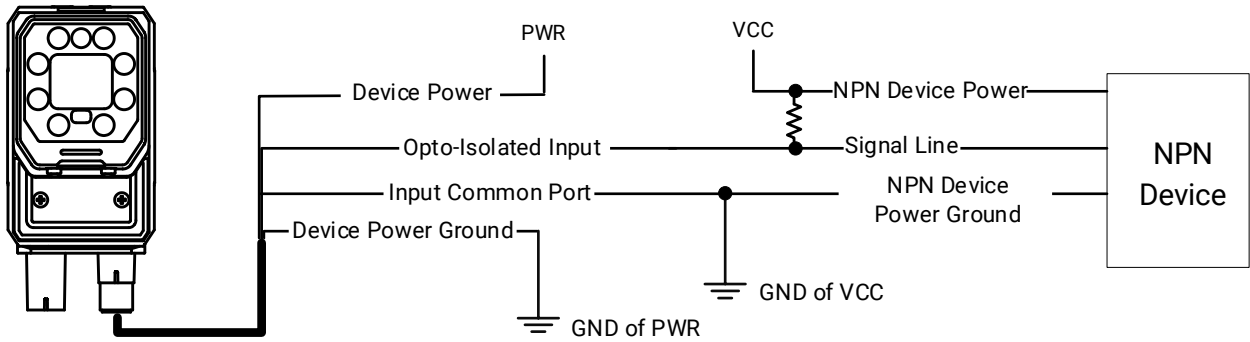

Figure 7-6 Input Signal Connecting to a NPN Device (with Pull-Up Resistor)

If no pull-up resistors are used, you can refer to the wiring below.

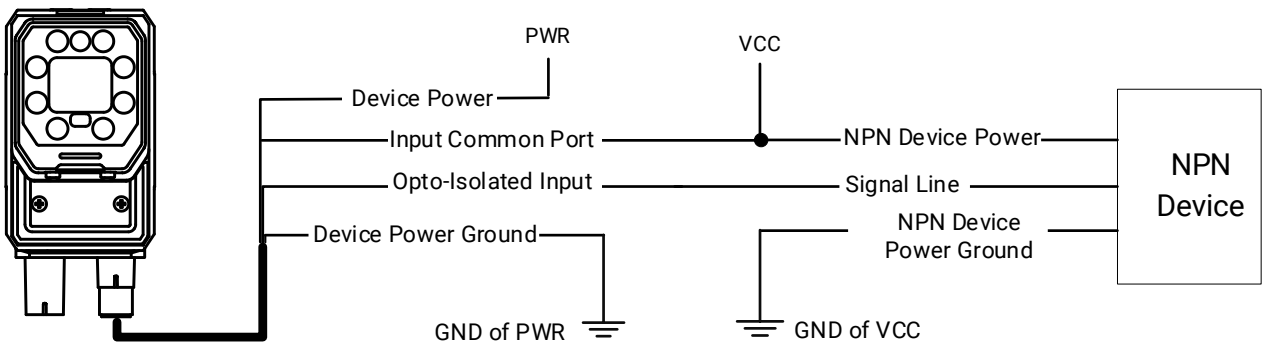

Figure 7-7 Input Signal Connecting to a NPN Device (Without Pull-Up Resistor)

7.2.2 Output Signal Wiring

The device can output signal to external device via I/O interface, and here we take Line 3 as an example to introduce output signal wiring.

Note

- Output signal wiring may differ by different types of external devices.
- The voltage of VCC from NPN device should be set as 12VDC or 24VDC according to the actual demand.
- The voltage of VCC should not be higher than that of PWR. Otherwise, the device's output signal may have exception.

PNP Device as External Device

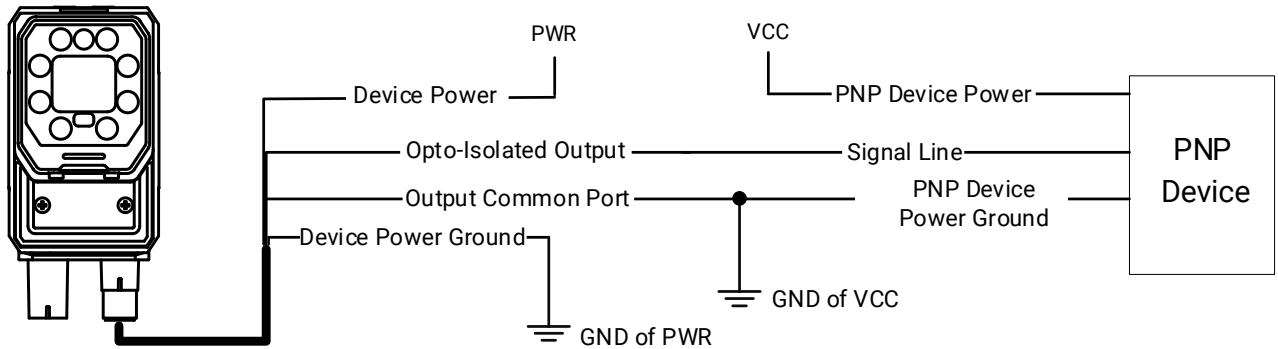

Figure 7-8 Output Signal Connecting to a PNP Device

NPN Device as External Device

It is recommended to use a 1 KΩ pull-up resistor, and you can refer to the wiring below.

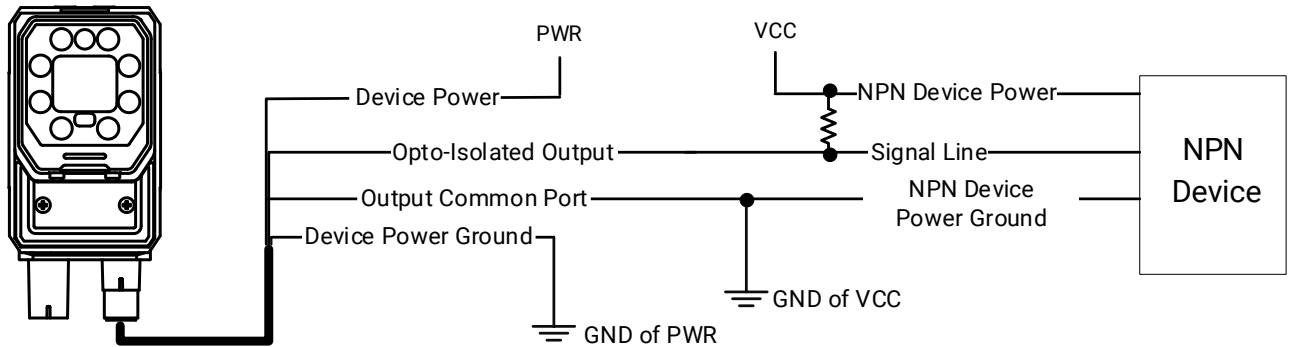

Figure 7-9 Output Signal Connecting to a NPN Device (with Pull-Up Resistor)

If no pull-up resistors are used, you can refer to the wiring below.

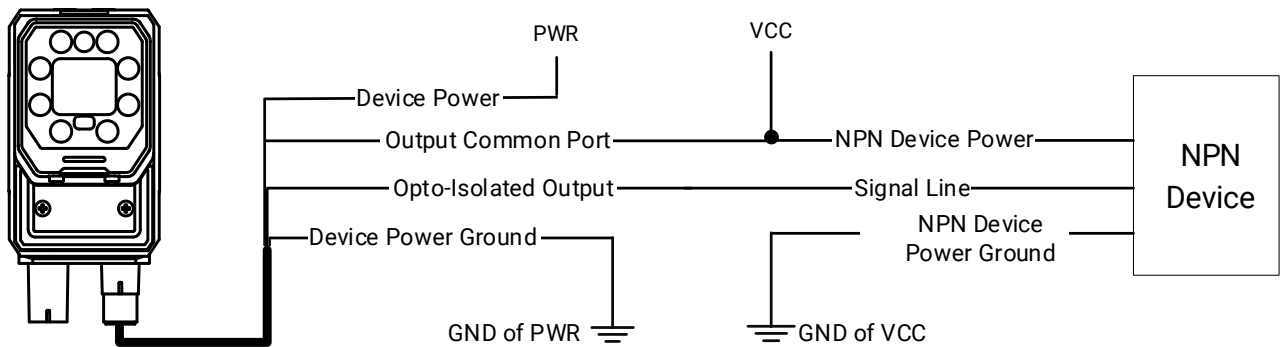

Figure 7-10 Output Signal Connecting to NPN Device (Without Pull-Up Resistor)

7.3 RS-232 Serial Port

The device supports output via RS-232 serial port. The 9-pin male connector and 25-pin male connector are commonly used serial ports, as shown below. You can refer to the table below for the specific pin name and function.

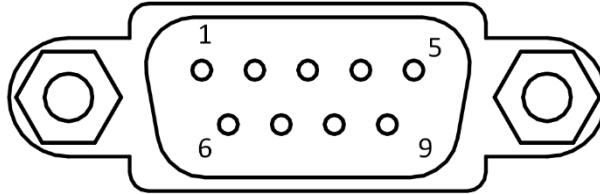

Figure 7-11 9-Pin Connector

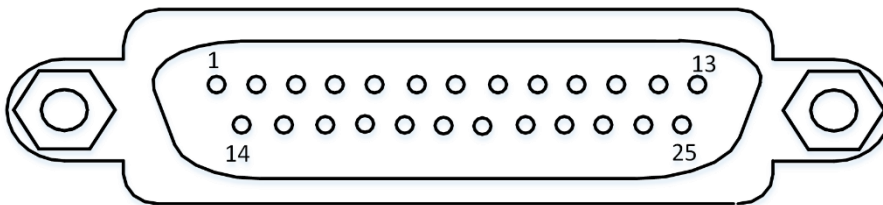

Figure 7-12 25-Pin Interface

Table 7-3 Pin Description

Serial Port Type	Pin No.	Name	Function
9-Pin Interface	2	RX	Receive data
	3	TX	Send data
	5	GND	Signal ground
25-Pin Interface	2	TX	Send data
	3	RX	Receive data
	7	GND	Signal ground

You can refer to the serial port wiring below to connect the device to an external device.

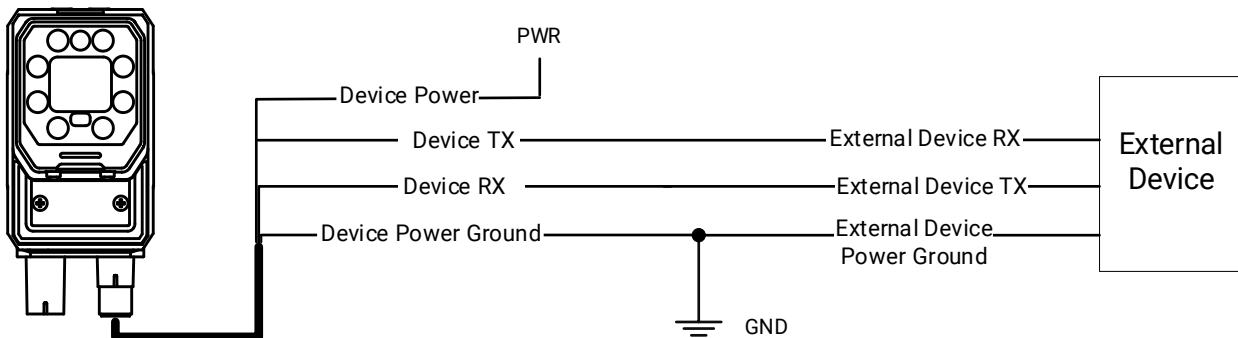

Figure 7-13 RS-232 Serial Port Wiring

Chapter 8 FAQ (Frequently Asked Question)

8.1 Why there is no device listed after I run the client software?

Table 8-1 Question 1

Possible Cause	Solution
The device is powered off.	Check the device's power connection (the indicator is solid blue if the device works normally) to make sure the device is powered up normally.
Network exception occurs.	Check the network connection (the indicator is solid orange if the network transmission is normal) to make sure the device can be connected to the network normally, and make sure that the industrial PC and the device are in the same network segment.

8.2 Why the image is very dark?

Table 8-2 Question 2

Possible Cause	Solution
Insufficient brightness of light source.	Increase the brightness of light source appropriately, or change to a brighter one.
Too small value of exposure and gain.	Increase exposure and gain appropriately.

8.3 Why the image's frame rate is very low in the live view?

Table 8-3 Question 3

Possible Cause	Solution
Network circuitry speed is not 1000 Mbit/s.	Check whether the network transit speed is 1000 Mbit/s or above.

8.4 Why there is no image in the live view?

Table 8-4 Question 4

Possible Cause	Solution
<p>LINE0 is selected as Trigger Source in VM client, but there is no trigger signal being sent to the device.</p>	<ul style="list-style-type: none">• Software trigger: The Trigger Mode is On, and the Trigger Source is SOFTWARE.• Hardware trigger: The Trigger Source is LINE0, and the signal has been sent to the device.• If triggering via external device is not required, please set the Trigger Mode as Off.