

THE1000



Model	THE1000	
Arm length (1st Arm + 2nd Arm)	1000 mm (550 mm+450 mm)	
Working envelope	Axis 1	±132 deg
	Axis 2	±152 deg
	Axis 3 (Axis Z)	0~420 mm
	Axis 4 (Axis C)	±360 deg
Maximum speed	Axis 1	300 deg/sec
	Axis 2	540 deg/sec
	Axis 3 (Axis Z)	2200 mm/sec
	Axis 4 (Axis C)	1100 deg/sec
	Composite (Axis 1 and 2 composite)	9500 mm/sec
Standard cycle time ^{*1}	0.44 sec (with 2 kg load)	
Maximum payload mass ^{*2}	20 kg (rated 5 kg)	
Allowable moment of inertia ^{*2}	0.6 kg·m ²	
Positioning repeatability ^{*3}	X-Y	±0.025 mm
	Axis Z (Axis 3)	±0.01 mm
	Axis C (Axis 4)	±0.01 deg
Hand wiring	8 inputs and 8 outputs	
Hand pneumatic joint	φ6 x 2 pcs φ8 x 2 pcs	
Robot controller cable	3.5 m	
Power supply	4.3 kVA	
Mass	49 kg	
Connectable controller	TS5000-MS	

For *1 to *3, please see page 8.

External View

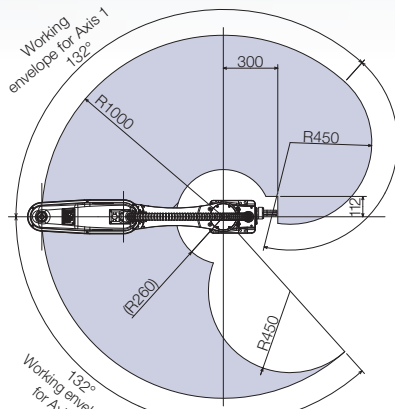

Working envelope for config lefty

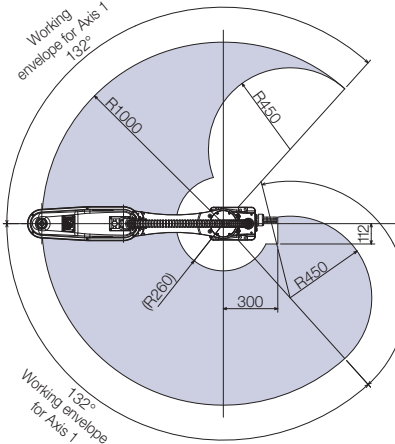

Working envelope for config righty

