

LION
PRECISION

EDDY-CURRENT SENSORS

Position • Displacement

High Speed • High Resolution

Off-The-Shelf and Customized Solutions



An Eddy-Current Sensor System

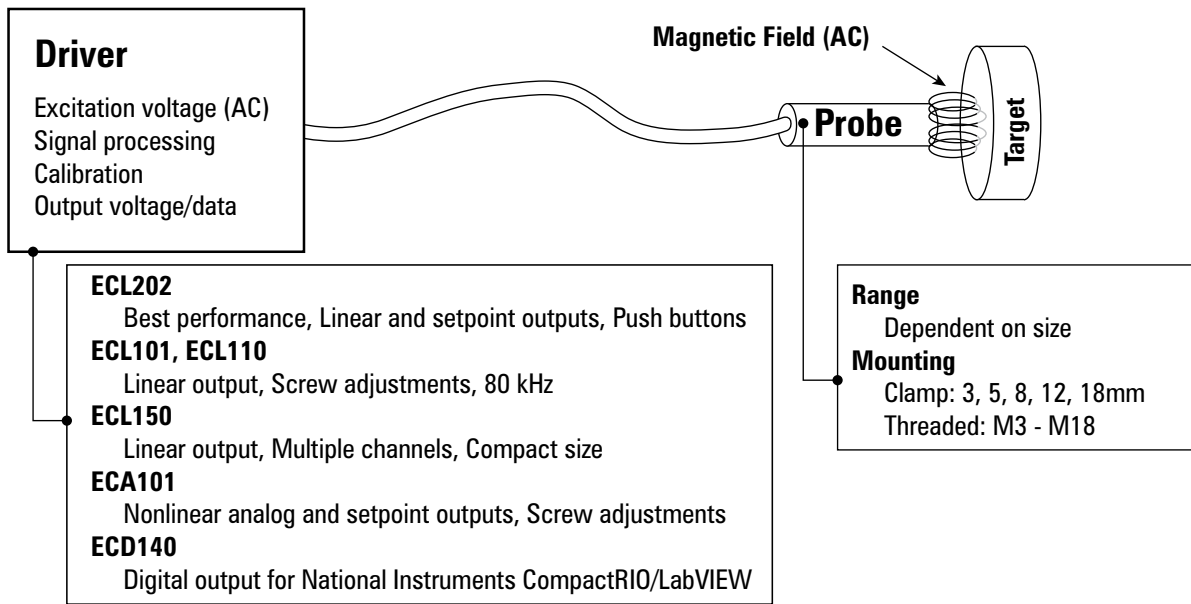

Eddy-Current Sensors

Basics

An eddy-current sensor produces an alternating magnetic field at the probe tip. When this field is near a conductive material, the field creates (induces) small electrical eddy-currents in the material. These currents generate a magnetic field that opposes the field from the sensor. As the gap between the probe and target gets smaller, the field interaction changes. The sensor electronics measure this field interaction and generate an output voltage proportional to the change in the gap.

Conductive Targets

The eddy-currents induced in the target material are dependent on the material's properties of permeability and resistivity. As a result, eddy-current sensors are sensitive to changes in material. There can be a drastic difference between magnetic (iron, steel) and nonmagnetic (aluminum, copper) materials. Less drastic, but still significant, is the difference between two nonmagnetic materials. The material and alloy must be specified with orders to assure an accurate calibration. Because the magnetic fields penetrate the surface of the target, target materials have minimum thickness requirements; this varies with material type. TechNote LT02-0011, Minimum Recommended Target Thickness details the minimum target thickness for many materials.

The TechNote is available at www.lionprecision.com; click on *Technical Library*.

Hostile Environments

The magnetic fields of eddy-current sensors do not "see" nonconductive materials and therefore are not affected by most contaminants. This allows an eddy-current sensor to operate while immersed in liquids and in the presence of machine coolants or other liquid materials present in the sensing area.

Maximizing Accuracy

Accuracy at the high resolutions created by precision eddy-current sensors may be affected by the environment and measurement setup. Target areas must be at least three times larger than the probe diameter. Probes must be positioned in a stable mechanical system in a stable environment. Even small changes in temperature cause expansions of the target that are detectable by high-resolution sensors.

Resolution

Resolution is a measurement system's smallest possible measurement. Resolution is essentially a measurement of electrical noise present at the sensor output. Eddy-current sensor resolution is a function of the bandwidth of the system. The lower the bandwidth, the better the resolution. When comparing specifications, *be sure to know the bandwidth at which the resolution is specified*.

Driver Comparison



Linear Analog Out	✓	✓	✓	✓		
Nonlinear Analog Out					✓	
Digital Output						CompactRIO
Setpoint Output	✓				✓	
Pushbutton Adjustment	✓					LabVIEW Control
Adjustable Gain			✓	✓	✓	LabVIEW Control
Adjustable Offset	✓		✓	✓	✓	LabVIEW Control
Range Indicator	✓	✓	✓	✓	✓	✓
Multichannel Package		✓		✓		
Selectable Bandwidth	0.1, 1, 10, 15 kHz	0.25, 1, 10, 15 kHz				LabVIEW Control
Nonlinearity	0.2%	0.2%	0.25-0.5%	0.25-0.5%	Nonlinear	0.2%
Resolution	0.002%–0.025%	0.002%–0.025%	0.004%–0.06%	0.004%–0.06%	0.02%	0.002%–0.025%
Maximum Bandwidth	15 kHz	15 kHz	80 kHz	80 kHz	10 kHz	15 kHz

Options

Standard calibrations are for standard range probes with 3 m cables and either 6061 aluminum or 4140 steel targets.

Options requiring custom calibration:

- Nonstandard Ranges

- Nonstandard Material (6061 aluminum and 4140 steel are standard)

- Nonflat Target Shape

- Custom Cable length

- Probe Extension Cables (2 m, 3 m, 4 m; must be calibrated and used with extension cable attached)

- Probe Vacuum Compatibility (to 10^{-6} Torr), Probe High-Vacuum Compatibility (below 10^{-6} Torr)

Accessories

DIN Rail Power Supply

ECA101 ECL101 ECL202
In:100-240 VAC 50-60Hz
Out:10 to15 VDC @2 A



Power Supply

ECL150
In:100-240 VAC 50-60Hz
Out:12 VDC @1.5 A



ECL101 Sync Kit

T-connectors and cables



ECL202 High-Resolution

FPGA-Based digital system for easy setup and high performance

High Performance

- Nonlinearity: 0.2%
- Resolution, Typical: Nonferrous: 15 kHz - 0.007%; 100 Hz - 0.002%
- Bandwidth: 100 Hz, 1 kHz, 10 kHz, 15 kHz (user selectable);

Easy Operation:

- Pushbutton Offset and Setpoint (Front Panel and Remote)
- Range Indicating LEDs
- Sync Multiple Units (factory shipped as single system)
- 0-10 VDC Output & Setpoint Switch Contacts

Export Limitations

Because of high resolutions, export of the ECL202 to some countries requires an export license. The ECL202e has different resolution specifications and can ship without an export license.



Function Descriptions

Pushbutton Offset: Shifts the DC level of the output voltage to 5 VDC (midscale) to establish repeatable reference point. Only functions when the probe is in the center 20% of its calibrated range.

Pushbutton Setpoint: Sets the setpoint voltage at which a contact closure output activates.

Specifications

Analog Output	0-10 VDC, 0 Ω , 15 mA max 15 μ s update rate
Setpoint Switched Output	30 VAC/60 VDC; 100 mA
Input Power	12-24 VDC, 2.5 W
Remote Offset and Setpoint Inputs	12-24 VDC to activate, 3-7 mA
Driver Operating Environment	4°C to 50°C, IP40

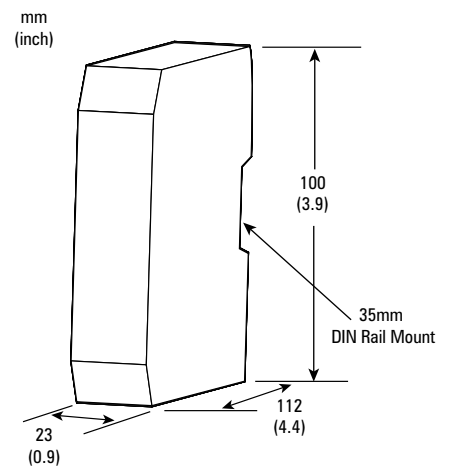

Range, Resolution, Thermal Drift

Specifications based on standard 3 m cable, target size 3 times probe diameter.

Probe Model	Range Type	Range mm inch	Near Gap mm inch	Material Type	Resolution ¹ @ Bandwidth					Thermal Drift ² %F.S./°C	
					ECL202				³ ECL202e	Probe	Driver
					100 Hz nm μinch	1 kHz nm μinch	10 kHz nm μinch	15 kHz nm μinch	15 kHz nm μinch		
U3	Fine	0.25 0.010	0.05 0.002	Nonferrous	10 0.4	15 0.6	25 1.0	30 1.2	—	0.04	0.04
				Ferrous	15 0.6	25 1.0	40 1.6	50 2.0	—	0.06	0.10
	Standard	0.50 0.020	0.05 0.002	Nonferrous	25 1.0	30 1.2	60 2.4	65 2.6	400 16	0.04	0.04
				Ferrous	30 1.2	40 1.6	100 4.0	110 4.4	400 16	0.08	0.08
U5	Fine	0.625 0.025	0.25 0.010	Nonferrous	30 1.2	35 1.4	70 2.8	75 3.0	—	0.04	0.04
				Ferrous	40 1.6	50 2.0	75 3.0	80 3.2	—	0.08	0.04
	Standard	1.25 0.050	0.25 0.010	Nonferrous	45 1.8	65 2.6	140 5.6	150 6.0	400 16	0.04	0.1
				Ferrous	80 3.2	120 4.8	240 9.6	260 10.4	400 16	0.1	0.1
U8	Fine	1.00 0.040	0.35 0.015	Nonferrous	20 0.8	30 1.2	50 2.0	60 2.4	—	0.02	0.04
				Ferrous	50 2.0	60 2.4	100 4.0	110 4.3	—	0.04	0.04
	Standard	2.00 0.080	0.35 0.015	Nonferrous	40 1.6	60 2.4	135 5.4	145 5.8	400 16	0.02	0.04
				Ferrous	70 2.8	80 3.2	180 7.2	200 8.0	400 16	0.04	0.04
U12	Fine	1.60 0.065	0.60 0.025	Nonferrous	40 1.6	50 2.0	100 4.0	110 4.4	—	0.01	0.01
				Ferrous	50 2.0	70 2.8	120 4.8	130 5.1	—	0.02	0.02
	Standard	3.50 0.140	0.60 0.025	Nonferrous	60 2.4	90 3.6	210 8.4	240 9.6	400 16	0.02	0.01
				Ferrous	100 4.0	170 6.8	250 10	300 12	400 16	0.03	0.01
U18	Standard	5.00 0.200	0.75 0.030	Nonferrous	80 3.2	130 5.2	300 12	340 14	400 16	0.01	0.01
				Ferrous	130 5.2	200 8.0	390 16	450 18	500 20	0.01	0.01
U25	Standard	8.00 0.320	1.25 0.050	Nonferrous	180 7.2	250 10	500 20	600 24	600 24	0.01	0.01
				Ferrous	180 7.2	250 10	500 20	600 24	600 24	0.01	0.01
U38	Standard	12.5 0.500	1.50 0.060	Nonferrous	200 8.0	350 14	700 28	800 32	800 32	0.01	0.01
				Ferrous	200 8.0	350 14	700 28	800 32	800 32	0.02	0.01
U50	Standard	15.0 0.600	2.00 0.080	Nonferrous	300 12	400 16	800 32	900 36	900 36	0.01	0.01
				Ferrous	300 12	450 18	900 36	1000 40	1000 40	0.01	0.01

¹Peak-to-Peak resolution is 8-10 times RMS resolution; in high EMI environments (10 V/m), output noise levels could rise to 30 mV RMS (0.3% resolution)

²Thermal Drift specified at: Probe: 15°C - 65°C; Driver: 15°C - 50°C except where noted

³The ECL202e does not require an export license

ECL150 Multichannel

Compact, Multi-Channel, Built on CompactFLEX Digital Technology

High Performance

- Nonlinearity: 0.2%
- Resolution (RMS): 0.002%–0.025% (Probe/Range dependent)
- Bandwidth: 250 Hz, 1 kHz, 10 kHz, 15 kHz (user selectable)

Features

- ± 5 VDC Outputs
- No User Adjustments
- Range Indicating LEDs
- Up to 8 Channels in One Compact Package
- Available Without Enclosure

Export Limitations

Because of high resolutions, export of the ECL150 to some countries requires an export license. The ECL150e has different resolution specifications and can ship without an export license.



Specifications

Analog Output	± 5 VDC, 0 Ω , 15 mA max 15 μ s update rate
Output Channels	Up to 8. Multiple units can be interconnected for more channels
Input Power	12-24 VDC, 1-2 Channels – 2.5 W 3-4 Channels – 3.5 W 5-6 Channels – 4.5 W 7-8 Channels – 5.5 W
Driver Operating Environment	4°C to 50°C, IP64

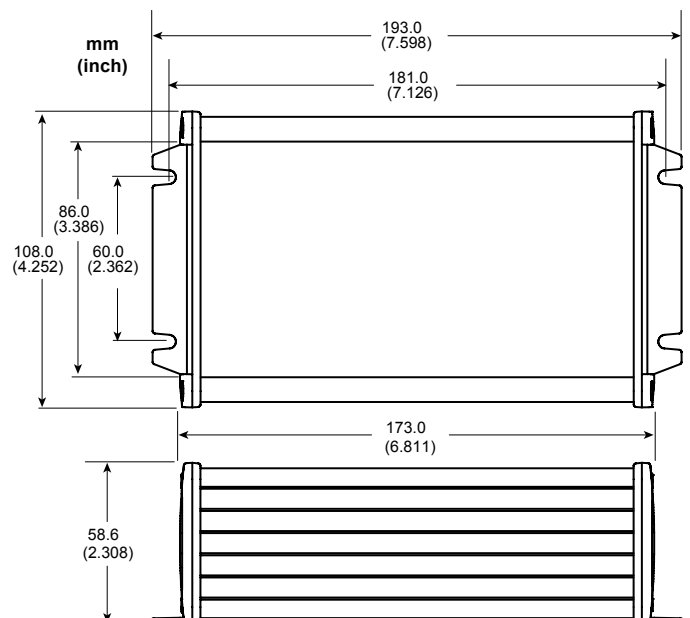

Range, Resolution, Thermal Drift

Specifications based on standard 3 m cable, target size 3 times probe diameter.

Probe Model	Range mm inch	Near Gap mm inch	Material Type	Resolution ¹ @ Bandwidth					Thermal Drift ² %F.S./°C	
				ECL150				³ ECL150e	Probe	Driver
				250 Hz nm μinch	1 kHz nm μinch	10 kHz nm μinch	15 kHz nm μinch	15 kHz nm μinch		
U3	0.50 0.020	0.05 0.002	Nonferrous	35 1.4	45 1.8	60 2.4	65 2.6	400 16	0.04	0.04
			Ferrous	60 2.4	80 3.2	100 4.0	110 4.4	400 16	0.08	0.08
U5	1.25 0.050	0.25 0.010	Nonferrous	75 3.0	100 4.0	140 5.6	150 6.0	400 16	0.04	0.10
			Ferrous	130 5.0	180 7.0	240 9.5	260 10	400 16	0.10	0.10
U8	2.00 0.080	0.35 0.015	Nonferrous	75 3.0	100 4.0	135 5.5	145 6.0	400 16	0.02	0.04
			Ferrous	100 4.0	125 5.0	180 7.0	200 8.0	400 16	0.04	0.04
U12	3.50 0.140	0.60 0.025	Nonferrous	120 4.8	160 6.3	210 9.0	240 10	400 16	0.02	0.01
			Ferrous	150 6.0	200 8.0	250 10	300 12	400 16	0.03	0.01
U18	5.00 0.200	0.75 0.030	Nonferrous	170 7.0	240 10	300 12	340 14	400 16	0.01	0.01
			Ferrous	230 9.0	300 12	390 16	450 18	500 20	0.01	0.01
U25	8.00 0.320	1.25 0.050	Nonferrous	330 13	430 17	600 24	650 26	650 26	0.01	0.01
			Ferrous	360 15	480 20	650 26	750 30	750 30	0.01	0.01
U38	12.5 0.500	1.50 0.060	Nonferrous	600 24	750 30	1000 40	1200 48	1200 47	0.01	0.01
			Ferrous	650 26	800 32	1100 44	1300 52	1300 51	0.02	0.01
U50	15.0 0.600	2.00 0.080	Nonferrous	750 30	1000 40	1300 52	1400 56	1400 55	0.01	0.01
			Ferrous	800 32	1100 45	1400 55	1500 60	1500 59	0.01	0.01

¹Peak-to-Peak resolution is 8-10 times RMS resolution; in high EMI environments (10 V/m), output noise levels could rise to 60 mV RMS (0.6% resolution) and DC level shift by 0.2 VDC. The 'e' version has higher resolution values so it does not require an export license.

²Thermal Drift specified at: Probe: 15°C - 65°C; Driver: 15°C - 50°C

³The ECL150e does not require an export license

ECL101 Wide Bandwidth

Linear, analog sensor with bandwidth to 80 kHz

Performance

- Nonlinearity: 0.5%
- Resolution: 0.004%–0.06% (see Range/Resolution table below)
- Bandwidth: 1 kHz, 10 kHz, 80 kHz (factory set)

Features

Easy Operation:

- 0-10 VDC Output
- Adjustable Zero (Front Panel and Remote)
- Range Indicating LEDs
- Sync Multiple Units (requires sync kit)
- 12-24 VDC Power
- Field Calibration

Export Limitations

Because of high resolutions, export to some countries of the ECL101 and ECL110 requires an export license.



Function Descriptions

Zero: Shifts output DC level

Specifications

Analog Outputs	0-10 VDC, 0 Ω, 15 mA max
Probe Thermal Drift at Mid-Range	0.04%/°C
Input Power	12-24 VDC, 2 W
Remote Offset (Zero)	±10 VDC analog voltage
Driver Operating Environment	4°C to 50°C, IP40

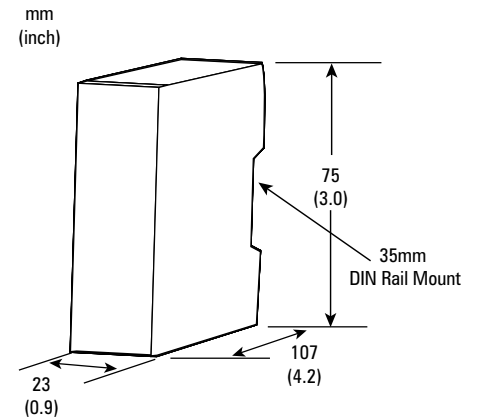

ECL110

For multi-channel applications, the ECL100 is available as a system of stacked circuit boards for maximum density in OEM applications. Up to eight channels can be ordered as a single system.

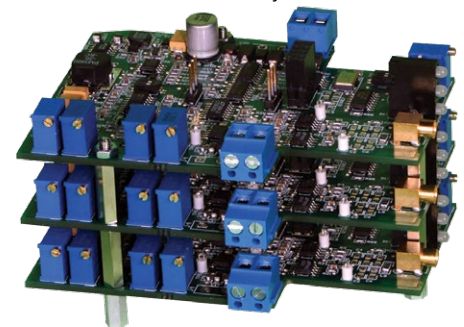
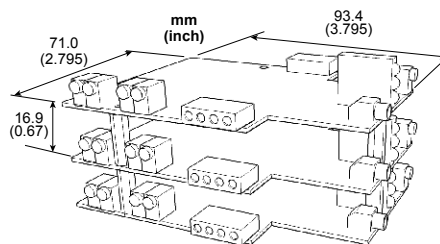

Range and Resolution

Specifications based on standard 3 m cable, target size 3 times probe diameter.

Probe Model	Range mm inch	Near Gap mm inch	Material Type	Resolution @ Bandwidth		
				1 kHz nm μinch	10 kHz nm μinch	80 kHz nm μinch
U3	0.50 0.020	0.05 0.002	Nonferrous	30 1.2	60 2.4	200 8.0
			Ferrous	40 1.6	80 3.2	300 12
U5	1.25 0.050	0.25 0.010	Nonferrous	60 2.4	100 4.0	250 10
			Ferrous	90 3.6	150 6.0	400 16
U8	2.00 0.080	0.35 0.015	Nonferrous	100 4.0	160 6.4	400 16
			Ferrous	130 5.2	210 8.4	500 20
U12	3.50 0.140	0.60 0.025	Nonferrous	200 8.0	280 11	700 28
			Ferrous	260 10	350 14	1200 48
U18	5.00 0.200	0.75 0.030	Nonferrous	240 10	480 19	3200 130
			Ferrous	320 13	640 26	4500 180
U25	8.00 0.320	1.25 0.050	Nonferrous	350 14	700 28	5300 210
			Ferrous	350 14	700 28	5300 210
U38	12.5 0.500	1.50 0.060	Nonferrous	550 22	1100 44	8300 330
			Ferrous	550 22	1100 44	8300 330
U50	15.0 0.600	2.00 0.080	Nonferrous	660 26	1300 52	10000 400
			Ferrous	660 26	1300 52	10000 400

¹Peak-to-Peak resolution is 8-10 times RMS resolution; in high EMI environments (10 V/m), output noise levels could rise to 30 mV RMS (0.3% resolution)

ECA101 Basic Sensor

Lower cost sensor for repeatable measurements

Performance

- Nonlinearity: Nonlinear sensor, see chart below
- Resolution: 0.02% RMS¹ @ 10 kHz
- Bandwidth: 10 kHz

Features

Easy Operation:

- Adjustable Gain and Offset (Zero)
- Range Indicating LEDs
- Adjustable Setpoint
- 12-24 VDC Power
- 0-10 VDC Analog Output
- Setpoint Switch Contacts

Export Limitations

Because of high resolutions, export of the ECA101 to some countries requires an export license.



Function Descriptions

Gain: Adjusts the sensitivity (output voltage change per unit of target position change)

Offset (Zero): Shifts output DC level

Setpoint (Switch): Adjusts analog output voltage at which setpoint switch closure occurs

Specifications

Analog Output		0-10 VDC, 0 Ω , 15 mA max
Probe Thermal Drift at Mid-Range		0.2%/°C
Setpoint Switched Output	Maximum Voltage	30 VAC/60 VDC
	Maximum Current	100 mA
	ON resistance	30-50 Ω
	OFF Leakage	1 μ A
	Hysteresis	0.1 V
	Response Time	0.25 mS On; 0.05 mS Off
Input Power		12-24 VDC, 2 W
Driver Operating Environment		4°C to 50°C, IP40

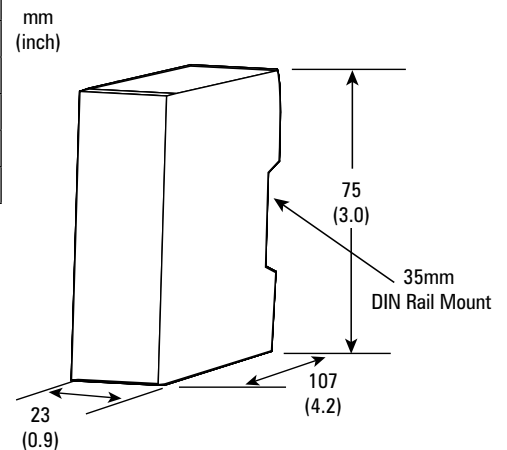

¹Peak-to-Peak resolution is approximately 8-10 times RMS resolution. In high EMI environments (10 V/m), output noise levels could rise to 600 mV RMS (6% resolution)

Ranges and Linearity

Specifications based on standard 3 m cable, target size 3 times probe diameter, and 6061 aluminum or 4140 steel targets.

Probe Model	Range	Near Gap
	mm inch	mm inch
U3	0.50 0.020	0.05 0.002
U5	1.25 0.050	0.25 0.010
U8	2.00 0.080	0.35 0.015
U12	3.50 0.140	0.60 0.025
U18	5.00 0.200	0.75 0.030
U25	8.00 0.320	1.25 0.050
U38	12.5 0.500	1.50 0.060
U50	15.0 0.600	2.00 0.080

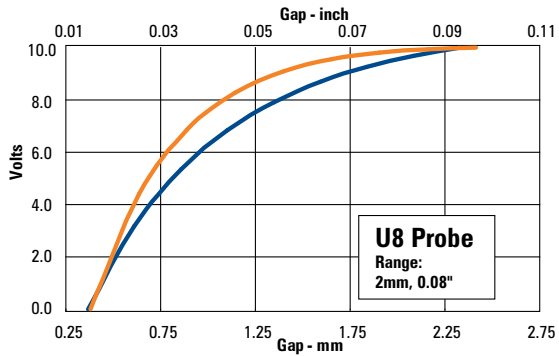

Typical output linearity (U8 example)

— 6061 Aluminum

— 4140 Steel

ECD140 CompactRIO Sensor



Noncontact displacement/position sensor for the CompactRIO system.

The ECD140 is intended for LabVIEW users experienced in FPGA and Real Time processor programming on the RIO platform. The device and the included software provide a tool kit for developers creating a complete system which requires precision noncontact displacement sensors. The system is not intended to be out-of-the-box operational, but requires implementation and programming by experienced LabVIEW FPGA users.

Performance

- Linearity: 0.2%
- Resolution: ECD140: 0.002-0.025% RMS
- Bandwidth: 15 kHz

Features

- Front Panel Indicator for Easy Setup
- Plugs into NI CompactRIO systems
- Instant LabVIEW Accessibility

Export Limitations

Because of high resolutions, export of the ECD140 to some countries requires an export license. The ECD140e has different resolution specifications and can ship without an export license.

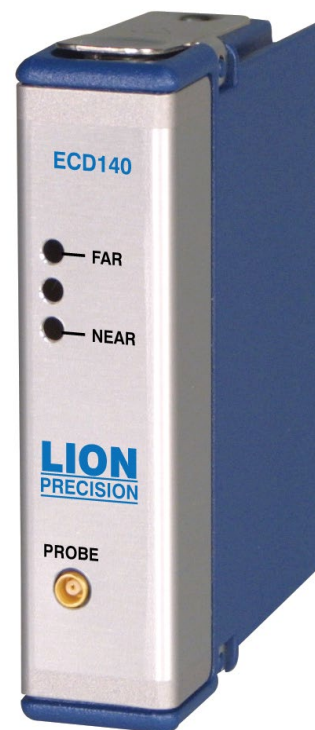

Specifications

Input Power	Supplied by RIO Chassis
Driver Operating Environment	4°C to 50°C, IP40



Range and Resolution

Specifications based on standard 3 m cable, target size 3 times probe diameter.

Probe Model	Range mm inch	Near Gap mm inch	Material Type	Resolution ¹ @ 15 kHz		Thermal Drift ² %F.S./°C	
				ECD140 nm μinch	³ ECD140e nm μinch	Probe	Driver
U3	0.50 0.020	0.05 0.002	Nonferrous: Aluminum 6061	TBD	TBD	TBD	TBD
			Ferrous: Steel 4140				
U5	1.25 0.050	0.25 0.010	Nonferrous	TBD	TBD	TBD	TBD
			Ferrous				
U8	2.00 0.080	0.35 0.015	Nonferrous	145 5.7	400 16	0.02	0.06
			Ferrous	180 7.1	400 16		
U12	3.50 0.140	0.60 0.025	Nonferrous	240 9.4	400 16	0.03	0.06
			Ferrous	300 12	400 16		
U18	5.00 0.200	0.75 0.030	Nonferrous	TBD	TBD	TBD	TBD
			Ferrous	TBD	TBD		
U25	8.00 0.320	1.25 0.050	Nonferrous	TBD	TBD	TBD	TBD
			Ferrous	TBD	TBD		
U38	12.5 0.500	1.50 0.060	Nonferrous	TBD	TBD	TBD	TBD
			Ferrous	TBD	TBD		
U50	15.0 0.600	2.00 0.080	Nonferrous	TBD	TBD	TBD	TBD
			Ferrous	TBD	TBD		

¹Peak-to-Peak resolution is 8-10 times RMS resolution. In high EMI environments, output noise may rise to 0.030 VRMS (0.3% resolution).

²Thermal Drift specified at: Probe: 15°C - 65°C; Driver: 15°C - 50°C

³The ECD140e has different resolution specifications and can ship without an export license.

Probes

- Probe identifiers begin with “U” and are created from the probe diameter (8 mm, 12 mm etc.) and the body style (B or C).
For example, a U8B probe is an 8 mm probe with a “B” body style.
- Extension cables must be factory calibrated with the system.
- Targets must be 3 times larger than probe diameter or custom calibration will be required.

Operating Environment

Probes are available in two environmental ranges:

- Standard: -25°C to 125°C, IP67
- High-Temperature: U3-U18: -25°C to 200°C, IP63
U25-U50: -25°C to 175°C, IP63

Vacuum compatible option available for most probes.

Measurement Ranges

Larger Probe = Larger Range

Custom ranges are available.

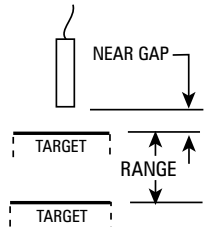

Probe	Minimum Target Diameter mm/inch	Standard Range		Fine Range (ECL202 Only)	
		Range mm/inch	Near Gap mm/inch	Range mm/inch	Near Gap mm/inch
U3	9/0.35	0.50/0.020	0.05/0.002	0.25/0.010	0.05/0.002
U5	15/0.60	1.25/0.050	0.25/0.010	0.625/0.025	0.25/0.010
U8	25/1.0	2.00/0.080	0.35/0.015	1.0/0.040	0.35/0.015
U12	36/1.4	3.50/0.140	0.60/0.025	1.6/0.065	0.60/0.025
U18	55/2.2	5.00/0.200	0.75/0.030	—	—
U25	75/3.0	8.00/0.320	1.25/0.050	—	—
U38	120/4.7	12.5/0.500	1.50/0.060	—	—
U50	150/6.0	15.0/0.600	2.00/0.080	—	—

Body Styles and Mechanical Detail

B

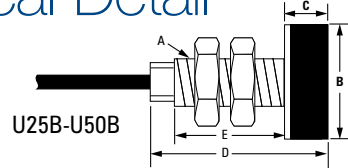
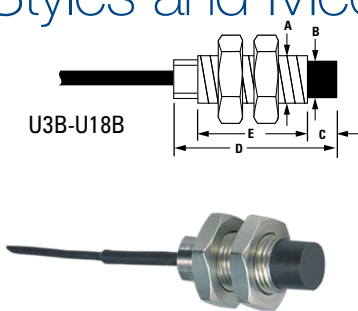

mm/inch	A	B	C	D	E	Wrench
U3B	M3x.5	2.0 / 0.08	3.0 / 0.12	21.1 / 0.83	13.0 / 0.51	5.5 / 0.22
U5B	M5x.8	3.4 / 0.13	3.0 / 0.12	25.0 / 0.99	18.0 / 0.71	8.0 / 0.31
U8B	M8x1	6.2 / 0.24	5.0 / 0.20	27.0 / 1.07	18.0 / 0.71	13.0 / 0.51
U12B	M12x1	10.0 / 0.39	7.0 / 0.28	29.0 / 1.15	18.0 / 0.71	17.0 / 0.67
U18B	M18x1	15.8 / 0.62	9.0 / 0.36	44.0 / 1.74	31.0 / 1.22	24.0 / 0.94
U25B	M18x1	25.0 / 0.99	15.0 / 0.59	61.0 / 2.40	42.0 / 1.65	24.0 / 0.94
U38B	M18x1	38.0 / 1.50	20.0 / 0.79	80.0 / 3.15	54.0 / 2.13	24.0 / 0.94
U50B	M18x1	50.0 / 1.97	25.0 / 0.99	98.0 / 3.86	69.0 / 2.72	24.0 / 0.94

Threaded stainless steel body for threaded or thru-hole mounting.

C

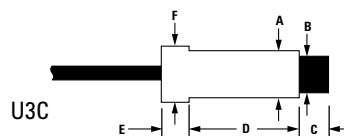
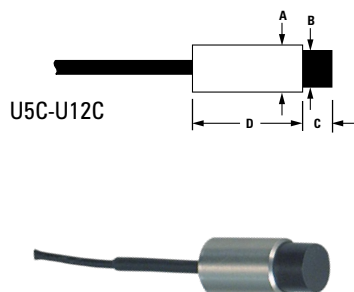

mm/inch	A	B	C	D	E	F
U3C	2.92 / 0.115	2.0 / 0.08	3.0 / 0.12	13.0 / 0.51	5.0 / 0.20	3.6 / 0.14
U5C	4.90 / 0.193	3.4 / 0.13	3.0 / 0.12	18.0 / 0.71		
U8C	7.90 / 0.311	6.2 / 0.24	5.0 / 0.20	18.0 / 0.71		
U12C	11.89 / 0.468	10.0 / 0.39	7.0 / 0.28	18.0 / 0.71		

Smooth stainless steel body for clamp or set-screw mounting.

Probe Cables

Cable length is three meters. Custom lengths are available

Extension cable length is measured from end-to-end including connectors.

Standard temperature probe cables have PUR jackets.
High-Temperature probes use PTFE.

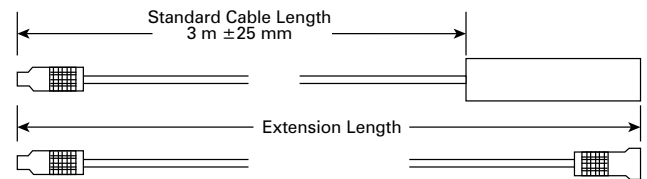

Armored Cable

Armored cable is available on probes 12 mm (U12) and larger. The armor is only affixed at the probe end.

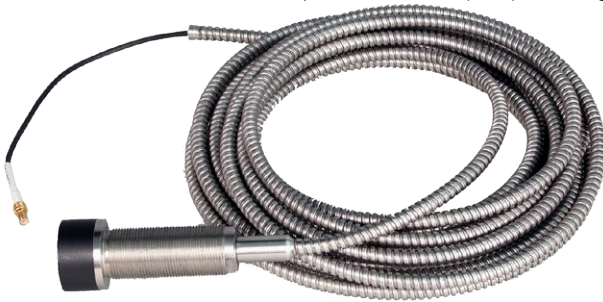

Mounting

Probes must be mounted to avoid interaction between the sensing field and the mounting hardware. The area within 3 probe diameters to the sides and 1.5 diameters behind should be kept clear of any metallic objects other than the object to be measured. Otherwise, custom calibration may be required.

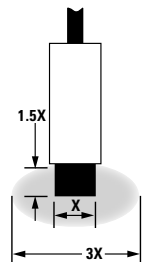

Exports

Export Considerations: Because of high resolutions, export to some countries requires an export license. The ECL202, ECL150m and ECD140 have 'e' versions (ECL202e, ECL150e, and ECD140e) which have different resolution specifications and can ship without an export license.

Contact us or see the lionprecision.com web site for details.



563 Shoreview Park Rd.
 St. Paul, MN 55126 USA
www.lionprecision.com
www.lionprecision.cn

Phone 651-484-6544
 Fax 651-484-6824
www.lionprecision.jp
info@lionprecision.com

Typical Applications

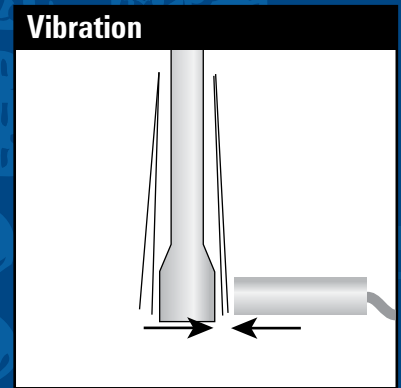
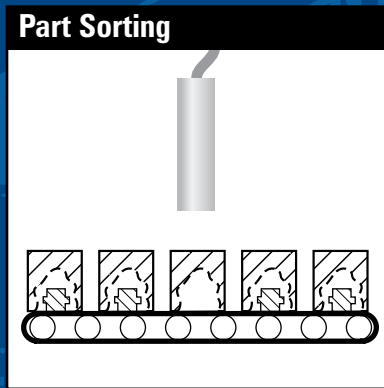
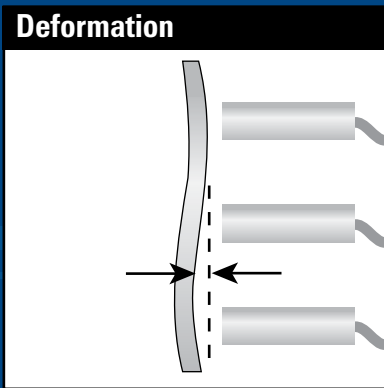
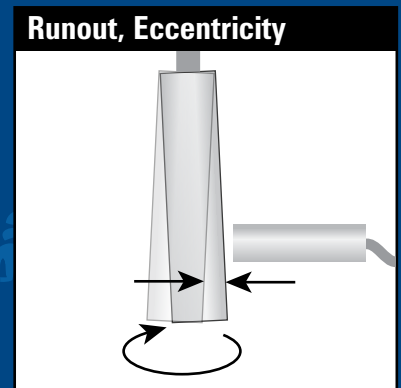
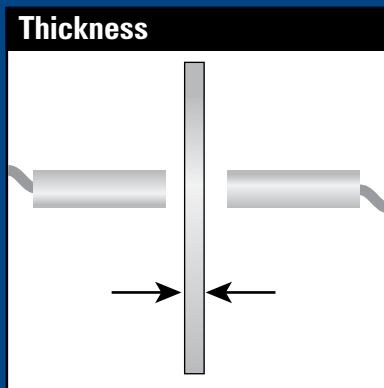
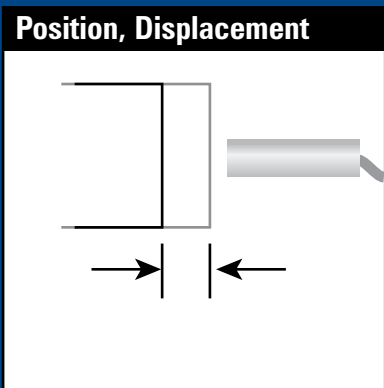

Commitment to Service

Lion Precision's commitment to service is unsurpassed in the industry. We partner with our customers to ensure their success by providing optimized sensing solutions. Contact us today and let us solve your difficult measurement problems.



Presented by: Absolute Gauge Technologies
sales@absolutegauge.com; www.absolutegauge.com,
 Toronto: 416 754 3168, Montreal: 514 695 5147, Toll Free: 1 888 754 7008