

Multifunction counter board, optically isolated, fast counter inputs – programmable functions, for PCI Express

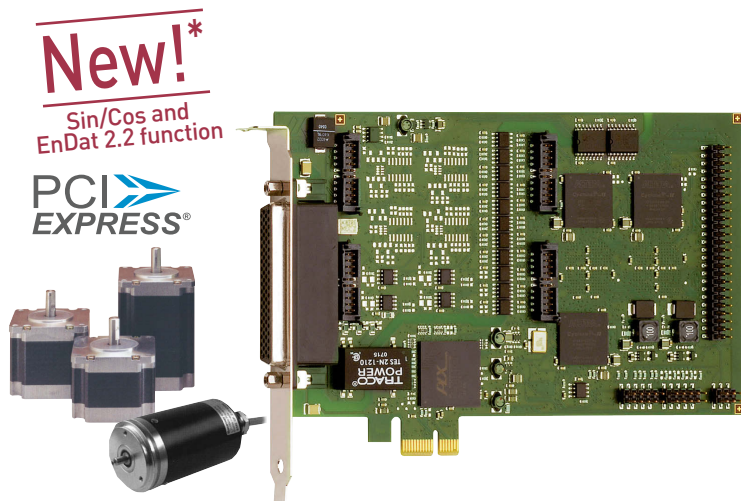

New!*

Sin/Cos and EnDat 2.2 function

PCI EXPRESS®



Also for **PCI**
see APCI-1710
page 178

Also for **CompactPCI™**
see CPCI-1710
page 246

Also for **CompactPCI™ Serial**
see CPCIs-1711
page 234

The board APCIe-1711 is a fast multifunction and multi-channel counter board for the PCI Express bus. The strengths of this board are its wide range of applications and high precision and reliability in harsh industrial environment.

With this board you can realise many different applications on the same hardware base. The board is supplied with a pool of functions which provides the user with maximum efficiency yet minimum space and parts requirement. The functions are individually configured for each channel through the supplied software. The flexible programming facilities on this board allow many different user applications to be quickly and easily developed and reconfigured as further requirements arise. Thanks to the FPGA board structure, further counting applications can be realised through software adaptation. Contact us!

Features

- 32-bit data access
- RS422 driver with 5 MHz max. (10 MHz for the APCIe-1711-10MHz – without ESD protection)
- With RS422/TTL input/output signals (APCIe-1711) or 24 V input signals (APCIe-1711-24V)
- Four onboard programmable function modules

Functions

- Incremental counter for the acquisition of incremental encoders (90° phase-shifted signals)
- BiSS-Master (B and C mode)
- SSI Synchronous Serial Interface. The SSI function is an interface for systems which allow an absolute position information via serial data transfer.
- Counter/timer (82C54)
- Pulse acquisition
- Frequency measurement
- Pulse width modulation (PWM)
- Period duration measurement
- Velocity measurement
- Digital inputs and outputs
- Edge time measurement (ETM)
- Parallel interface
- Sin/Cos (1 V_{pp}, 11 μA_{pp})
- EnDat 2.2
- Customised functions

Available channels on one function module

- 4 channels, programmable either as digital inputs or outputs, optically isolated, RS422
- 3 channels, digital inputs, optically isolated, 24 V
- 1 digital power output, optically isolated, 24 V

APCIe-1711

Available functions:

Incremental counter, SSI Synchronous Serial Interface, counter/timer, pulse acquisition, frequency, pulse width, period duration, velocity measurement, PWM, BiSS-Master, digital inputs and outputs, Sin/Cos, EnDat 2.2 ...

Function selection through software

Optical isolation

Inputs and outputs: RS422, TTL, 24 V

Customised functions

Additional channels

- 28 TTL I/O, without optical isolation

Versions

	RS422/ TTL- I/O	24 V inputs	5 V inputs	24 V outputs	TTL I/O
APCIe-1711	16	12	–	4	28
APCIe-1711-24V	–	28	–	4	28
APCIe-1711-5V-I	16	–	12	4	28
APCIe-1711-10MHz	16	12	–	4	28

Safety features

- Creeping distance IEC 61010-1
- Optical isolation 1000 V
- Noise neutralisation of the PC supply

Applications

- Event counting
- Position acquisition
- Motion control
- Batch counting
- ...

Software drivers

A CD-ROM with the following software and programming samples is supplied with the board.

Standard drivers for:

- Linux
- 32-bit drivers for Windows 8 / 7 / Vista / XP / 2000
- Signed 64-bit drivers for Windows 8 / 7 / XP
- Real-time use with Linux and Windows on request

Drivers and samples for the following compilers and software packages:

- Microsoft VC++ • Borland C++ 5.01

On request:

Further operating systems, compilers and samples.

Driver download: www.addi-data.com/downloads



on request



LabVIEW™

* Preliminary
product information

Wide range of applications through the free combination of functions

4 function modules quickly and easily programmable with numerous functions

Each of the four modules is programmed with one function. You can program 4 times the same function or freely combine 4 different functions.

Configuration example 1			
Function module 0	Function module 1	Function module 2	Function module 3
Incremental counter	Incremental counter	Pulse acquisition	Counter/Timer

Configuration example 2			
Function module 0	Function module 1	Function module 2	Function module 3
SSI	SSI	Incremental counter	digital I/O

Programmable onboard modules

Each module can be programmed with the function of your choice. You can operate simultaneously up to 4 different functions on one board. If your application must be modified, you can load a new function quickly and easily.

Overview of signal generators resp. functions

Application	Max. number of signal generators or functions for each function module	Max. number of function modules for each APCLe-1711	Max. number of signal generators or functions of each APCLe-1711	Page
Incremental counter	1 (32-bit) or 2 (16-bit)	4	4 or 8	180
SSI	3	4	12	180
Chronos	1	4	4	181
BiSS-Master	6	4	24	142
Counter/Timer	3	4	12	182
TOR	2	4	8	183
Pulse acquisition	4	4	16	184
PWM	2	4	8	184
ETM	2	4	8	185
Digital I/O	8	4	32	185
TTL	24	1	24	-
Parallel Interface	1	4	1	142
Sin/Cos*	2	2	4	144
EnDat 2.2	2	4	8	143

*Extension module (EM) is required



Customer-tailored modifications, designed to suit your needs. Hardware and software, firmware, PLDs, ... Contact us!

Simplified block diagram

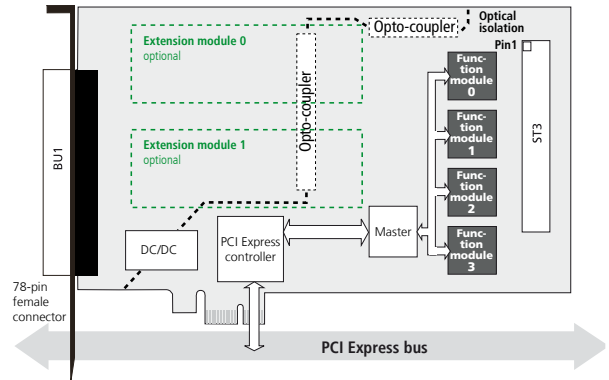

Pin assignment – 78-pin D-Sub female connector

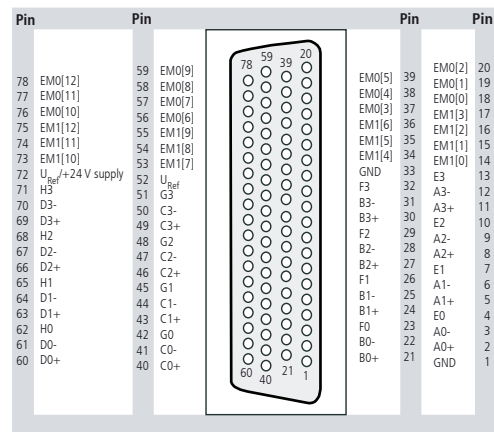

EM = Extension module

ADDI-DATA connection

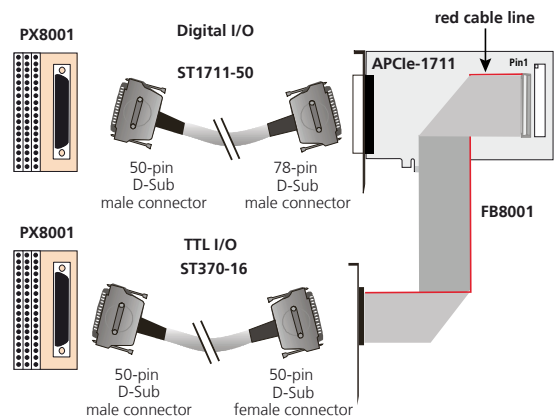

Function Parallel Interface On request

With the **Parallel Interface** function, the digital inputs of the APCLe-1711 are acquired in parallel. Up to 28 digital inputs, 24 V, can be acquired with the APCLe-1711-24 V. Up to 16 RS422 and 12 digital 24 V inputs can be acquired with the APCLe-1711.

There are different methods for the acquisition of the inputs:

- Timer controlled (max. resolution 1 μs = 1 MHz)
- Digital input (by masking the digital inputs, rising or falling edge)
- Software

This function can be loaded up to 4 times for each APCLe-1711, i.e. it is possible to acquire 8-bit (7 inputs), 16-bit (14 inputs), 24-bit (21 inputs) or 32-bit (28 inputs) in parallel. If an external trigger signal is used (maskable, rising or falling edge), there is no need to use one of the inputs for triggering.

The data is transferred directly via DMA into the RAM of the PC. If the **Parallel Interface** function is loaded on all function modules up to 28 digital inputs (RS422 / 24 V) are available.

Used signals

Pin name	Signal type	Function
Ax +/-	24 V*/ RS422	Digital input
Bx +/-	24 V*/ RS422	Digital input
Cx +/-	24 V*/ RS422	Digital input
Dx +/-	24 V*/ RS422	Digital input
Ex	24 V	Digital input
Fx	24 V	Digital input
Gx	24 V	Digital input

The 24 V switching level can be adjusted optionally down to 1 V

x: Number of the function module (See pin assignment page 141)
* 24 V for the APCLe-1711-24 V

Block diagram Parallel Interface

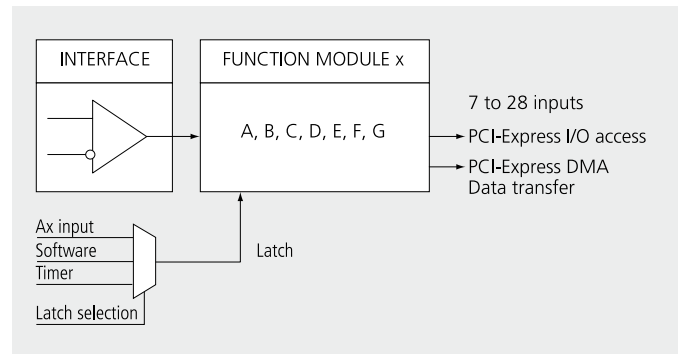

Function BiSS-Master

The **BiSS-Master** function is a bidirectional sensor interface for the communication with up to 6 sensors. BiSS B and C are supported.

Features of the BiSS-Master function:

- 1 function module with a maximum amount of 6 sensors (3 per channel) for cascading the sensors it is necessary that each sensor has a data input and data output
- Read sensor data
- Read/write register data

Get more information about the function range of the BiSS interface at www.biss-interface.com.

Used signals

Signal name	Pin name	Signal type	Function
Output_Ch0_x	Ax +/-	RS422	Dig. output 0 (clock line from master to slave) MA0
Input_Ch0_x	Bx +/-	RS422	Dig. input 0 (data line from slave to master) SL0
Output_Ch1_x	Cx +/-	RS422	Dig. output 1 (clock line from master to slave) MA1
Input_Ch1_x	Dx +/-	RS422	Dig. input 1 (data line from slave to master) SL1

Block diagram BiSS-Master

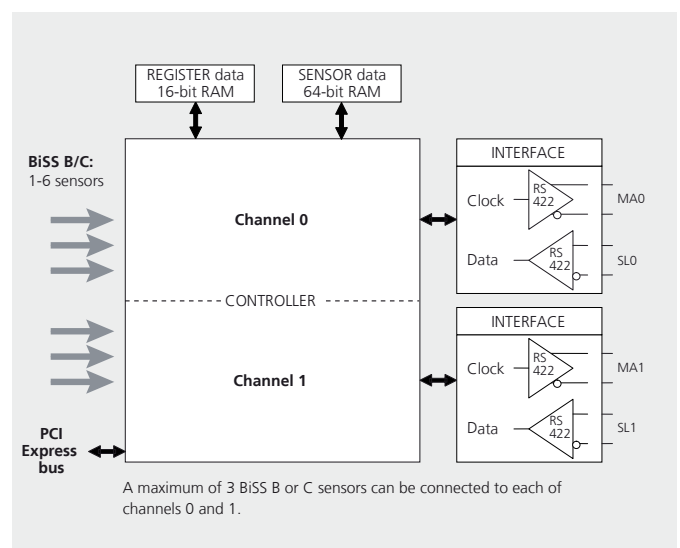

x: Number of the function module (See pin assignment page 141)



Function EnDat 2.2 New!

EnDat 2.2 is a bidirectional synchronous-serial interface for position measurement devices. This interface allows the reading out of absolute position values and parameters, the writing of status and initialisation registers and the transfer of additional information about the position value. Furthermore, the **EnDat 2.2** function modules support the analysis of diagnostic values and access to the OEM memory. Data transfer is effected serially.

On one board you can use up to 8 **EnDat 2.2** sensors (2 sensors per function module). Each function module has its own clock pulse line (B or D) and data line (A or C).

The function EnDat 2.2 is only available for the APcLe-1711!
(not for the APcLe-1711-24V and APcLe-1711-5V-I)

Block diagram EnDat 2.2

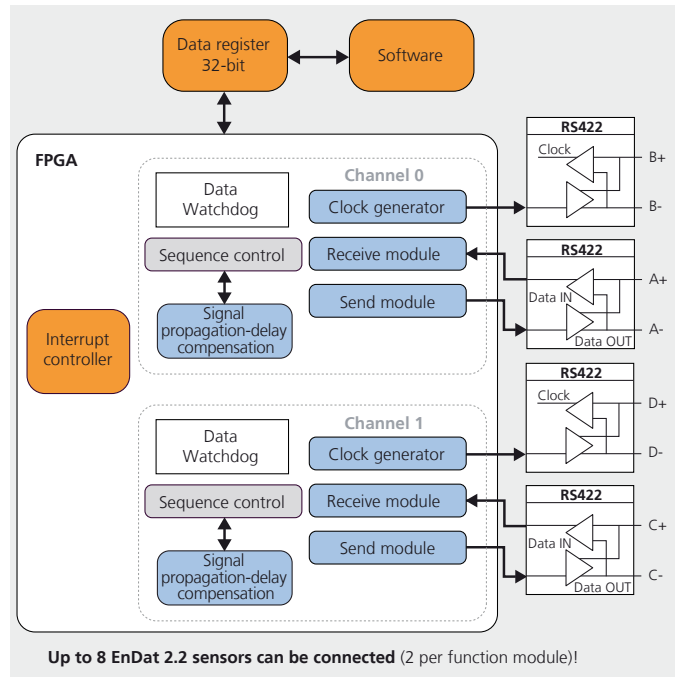

Used signals

Channel	Signal name	I/O	Pin name	Function
0	CLK_0+	0	Bx +	Clock pulse line
0	CLK_0-	0	Bx -	Clock pulse line
0	DATA_0+	I/O	Ax +	Data line
0	DATA_0-	0	Ax -	Data line
1	CLK_1+	0	Dx +	Clock pulse line
1	CLK_1-	0	Dx -	Clock pulse line
1	DATA_1+	I/O	Cx +	Data line
1	DATA_1-	0	Cx -	Data line
Dig. I/O	DigIn0_x	I (24 V)	Ex	Digital channel for unrestricted use
Dig. I/O	DigIn1_x	I (24 V)	Fx	Digital channel for unrestricted use
Dig. I/O	DigIn2_x	I (24 V)	Gx	Digital channel for unrestricted use
Dig. I/O	DigOut_x	O (24 V)	Hx	Digital channel for unrestricted use

x: Number of the module (See pin assignment page 141)

Application example

Exact positioning of axes for the regulation of surface measurement devices for rotationally symmetric parts (e.g. gear wheels)

Challenge

For the measurement of the surfaces of rotationally symmetric parts numerous axes must be positioned. Furthermore the signals must be fastly transferred in order to detect the position as exactly as possible. To save time, absolute encoders are used because they do not need any reference runs when started.

Solution

The measurement device consists of a measurement table with a gate. The rotationally symmetric parts are fixed on the measurement table and their surface is tested with a sensor connected to the gate. To move the sensor around the parts the gate has several axes equipped with EnDat 2.2 absolute encoders. The precision of the axis position is assured by the PCI Express counter board APcLe-1711: Thanks to its high input speed of 10 MHz (optional APcLe-1711-10MHZ version) and its resistance to interferences, the board is able to move the axes precisely even at high speed.

EnDat 2.2

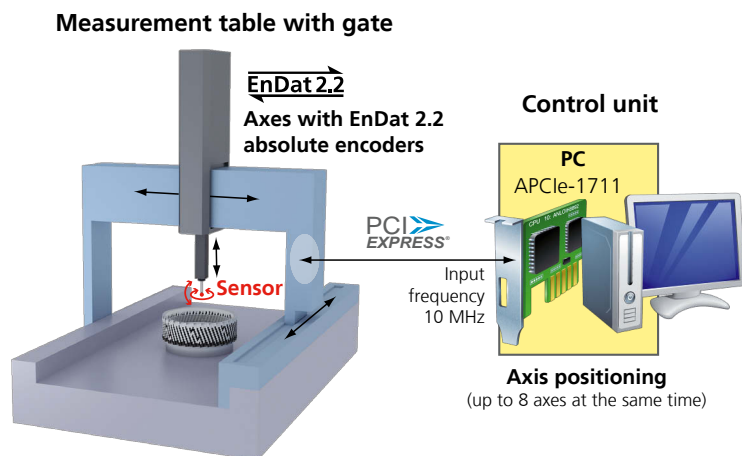

Function Sin/Cos New!

With the function **Sin/Cos**, up to 4 Sin/Cos sensors can be used on one board (function module 0 or 1 as well as 2 or 3). The extension module EM-SINCOS-1V_{pp} is meant for the connection of signals with 1 V_{pp}, the EM-SINCOS-11μA_{pp} is able to acquire 11 μA_{pp} signals. A signal period of the Sin/Cos signal is divided in a predefined number of steps, depending on the chosen resolution. The maximum input frequency of the counter input also depends on the chosen resolution.

Please note: The function **Sin/Cos** can only be used with the extension module EM-SINCOS.

Used signals

Signal name	Signal type	Function
EMx_Sin0+	1 V _{pp} /11 μA _{pp} diff.	Trace A+ (Sinus) of Sin/Cos sensor 0
EMx_Sin0-	1 V _{pp} /11 μA _{pp} diff.	Trace A- (Sinus) of Sin/Cos sensor 0
EMx_Cos0+	1 V _{pp} /11 μA _{pp} diff.	Trace B+ (Cosinus) of Sin/Cos sensor 0
EMx_Cos0-	1 V _{pp} /11 μA _{pp} diff.	Trace B- (Cosinus) of Sin/Cos sensor 0
EMx_Index0+	differential	Trace C+ (Index) of Sin/Cos sensor 0
EMx_Index0-	differential	Trace C- (Index) of Sin/Cos sensor 0
EMx_Sin1+	1 V _{pp} /11 μA _{pp} diff.	Trace A+ (Sinus) of Sin/Cos sensor 1
EMx_Sin1-	1 V _{pp} /11 μA _{pp} diff.	Trace A- (Sinus) of Sin/Cos sensor 1
EMx_Cos1+	1 V _{pp} /11 μA _{pp} diff.	Trace B+ (Cosinus) of Sin/Cos sensor 1
EMx_Cos1-	1 V _{pp} /11 μA _{pp} diff.	Trace B- (Cosinus) of Sin/Cos sensor 1
EMx_Index1+	differential	Trace C+ (Index) of Sin/Cos sensor 1
EMx_Index1-	differential	Trace C- (Index) of Sin/Cos sensor 1
EMx_DIG_IN	24 V / optional 5 V	Digital trigger input (can be used for latch resp. interrupt logic)
DigIn0_y	24 V / optional 5 V	Digital input for unrestricted use
DigIn1_y	24 V / optional 5 V	Digital input for unrestricted use
DigIn2_y	24 V / optional 5 V	Digital input for unrestricted use
DigOut_y	24 V	Digital output for unrestricted use

x: Number of the extension module (0 resp. 1); y: Number of the function module (0 to 3)

Block diagram Sin/Cos

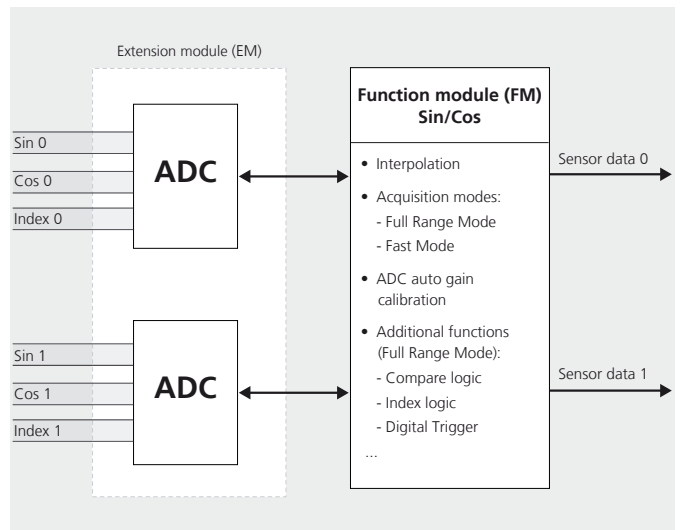

Pin assignment – 50-pin D-Sub male connector

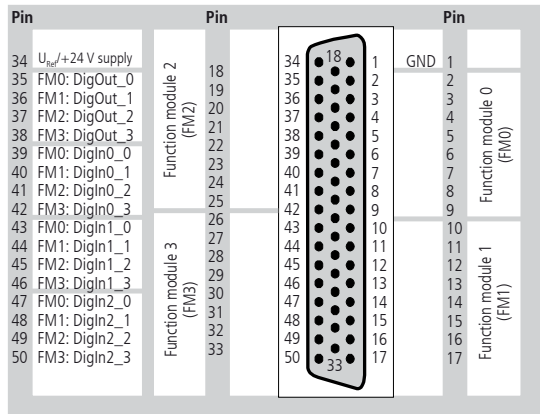

FM = Function module

ADDI-DATA connection

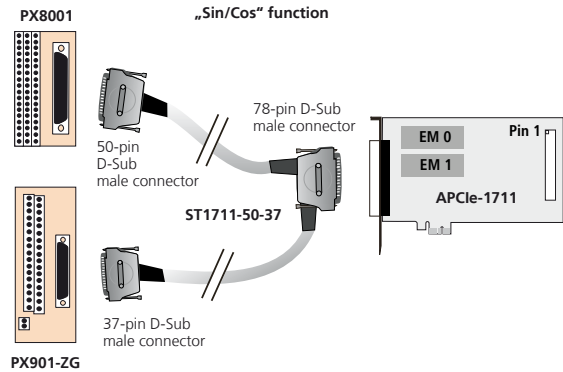

Pin assignment – 78-pin D-Sub female connector

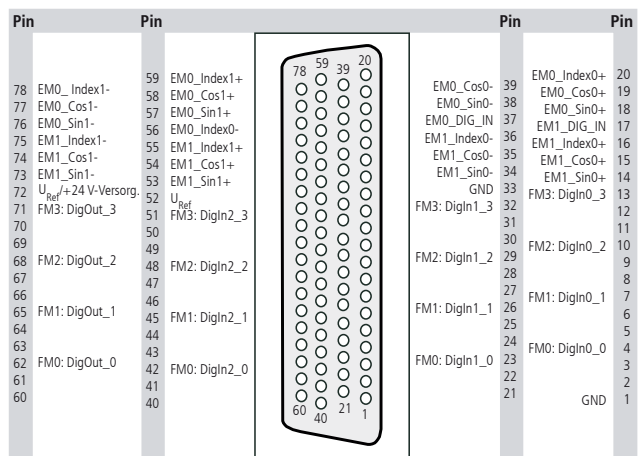

EM = Extension Module

FM = Function module

Pin assignment – 37-pin D-Sub male connector

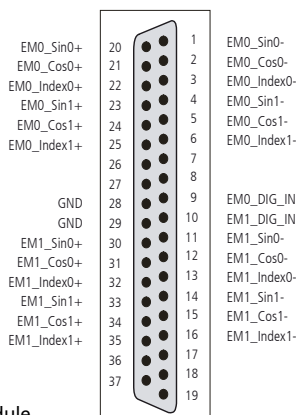

EM = Extension Module

Specifications*

Free programming of the functions

- Acquisition of incremental encoders (1 x 32-bit or 2 x 16-bit)
- SSI (max. 3 encoders per module)
- Counter/Timer (3 counters similar to 82C54)
- Pulse counter (4 x 32-bit counters per module)
- Chronos (chronometer)
- TOR (pulse counter with time slices, ...)
- Digital I/O (8 I/O, 24 V, TTL, RS422)
- PWM (pulse width modulation, 2 x per module)
- BiSS-Master (B and C mode)
- ETM (Timer interface for period duration measurement, edge time, ...)
- TTL (TTL I/O without isolation)
- Parallel Interface
- EnDat 2.2
- Sin/Cos
- Customised functions

Signals

Digital I/O signals, TTL or RS422, 24 V

Inputs

Differential inputs or outputs (A, B, C, D)

Differential inputs, RS422:	16 (can be used as inputs or outputs)
Nominal voltage:	3.3 VDC
Common mode range:	+12 V / -7 V
Input sensitivity:	200 mV
Input hysteresis:	50 mV
Input impedance:	12 kΩ
Terminal resistor:	120 Ω (not supplied)
Max. input frequency:	APCle-1711: 5 MHz (at nominal voltage) APCle-1711-10MHz: 10 MHz (at nominal voltage)

Mass-related inputs, 24 V (E, F, G):

Number of inputs:	12
Nominal voltage:	24 VDC
Logic input levels:	Unominal: 24 V UH max.: 30 V UH min.: 19 V UL max.: 14 V UL min.: 0 V

Maximal input frequency: 1 MHz (at nominal voltage) depending on the function

Outputs

Nominal voltage:	3.3 VDC
Maximum output frequency:	5 MHz (diff. outputs)
Max. number of outputs:	16 (if they are not used as diff. inputs)

Digital outputs, 24 V (H)

Output type:	High-side (load to ground)
Number of outputs:	4
Nominal voltage:	24 VDC
Supply voltage range:	4.75 V to 35 VDC (via 24 V ext. pin)
Maximum current:	90 mA per output / 270 mA for all outputs (PTC)
Overtemperature:	165 °C (all outputs switch off)

Technical data APCle-1711-24V version

24 V inputs (channels A to G).
This board version is intended for the connection of 24 V encoders.
Only 24 V signals can be connected to the inputs.

Nominal voltage:	24 VDC
Max. input frequency:	1 MHz (at nominal voltage) depending on the function
Logic input levels : (Standard)	Unominal: 24 V UH max.: 30 V UH min.: 18 V UL max.: 16 V UL min.: 0 V

Functions

On the board APCle-1711-24V Ax, Bx, Cx and Dx are only available as 24 V inputs and not as outputs. Therefore not any function can be used on any version of the board.

Available functions:
- Incremental counter
- Sin/Cos
Partially available:
- PWM

Please find more detailed information in the respective function manual.

Safety

Optical isolation: 1000 V

EMC – Electromagnetic compatibility

The product complies with the European EMC directive. The tests were carried out by a certified EMC laboratory in accordance with the norm from the EN 61326 series (IEC 61326). The limit values as set out by the European EMC directive for an industrial environment are complied with. The respective EMC test report is available on request.

PC system requirements and environmental conditions

Dimensions:	168 x 98 mm
System bus:	Acc. to PCI Express base specification, Revision 1.0a (PCI Express 1.0a)
Space required:	1-/4-/8-/16-lane PCI Express slot
Operating voltage:	+ 3.3 V / + 12 V from the PC +24 V ext.
Current consumption APCle-1711:	3.3 V / 341 mA 12 V / 76 mA typ.
Front connector:	78-pin D-Sub female connector
Additional connector:	50-pin D-Sub male connector
Temperature range:	0 to 60 °C (with forced cooling)

Ordering information

APCle-1711

Multifunction counter board, optically isolated, fast counter inputs – programmable functionality, for PCI Express.
Incl. technical description and software drivers.

- APCle-1711:** Isolated counter board with programmable functionality
APCle-1711-24V: 24 V instead of RS422 (A, B, C, D)
APCle-1711-5V-I: 5 V inputs instead of 24 V (E, F, G)
APCle-1711-10MHz: Input frequency 10 MHz, Inputs (A, B, C, D)

Option

Opt. 5V: 3.3 V outputs instead of 24 V (H0, H1, H2, H3)

Accessories

- PX8001:** 3-row screw terminal panel with housing for DIN rail
ST1711-50: Standard round cable, shielded, twisted pairs, 2 m, 78-pin male connector to 50-pin male connector

For the TTL I/O function

- ST370-16:** Standard round cable, shielded, twisted pairs, 2 m
FB8001: Ribbon cable

For the Sin/Cos function

- EM-SINCOS-11µAPP:** Extension module, 2 x 11 µA_{pp} inputs, 1 dig. output, 24 V
EM-SINCOS-1VPP: Extension module, 2 x 1 V_{pp} inputs, 1 dig. output, 24 V
ST1711-50-37: Y-cable, round, shielded, twisted pairs, 78-pin D-Sub male connector to 50-pin D-Sub male connector and 37-pin D-Sub male connector
PX901-ZG: Screw terminal panel for DIN rail

*Preliminary product information