

MVL-HF2528M-6MPE

1/1.8" 25mm 6MP FA LENS

HF-E series FA Lens are optimized for machine vision light sources and sensor, with high resolution, excellent image quality, high transmittance and good stability. Featured with fixed focal length, manual aperture and compact size, it is suitable for machine vision industry applications and ideal for industrial cameras.



Key Features

- Higher image clarity and contrast ratio
- Ultra-low distortion and higher relative illumination rate
- Good optical performance at ultra-short working distance
- Compact design, convenient for device integration

Distortion

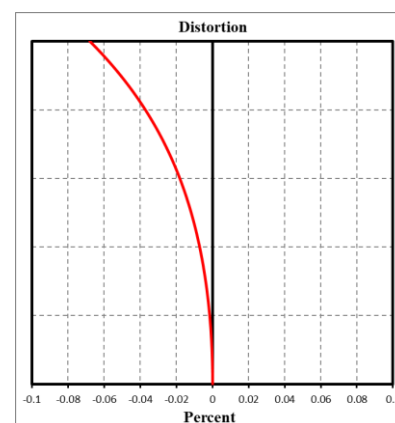

MTF

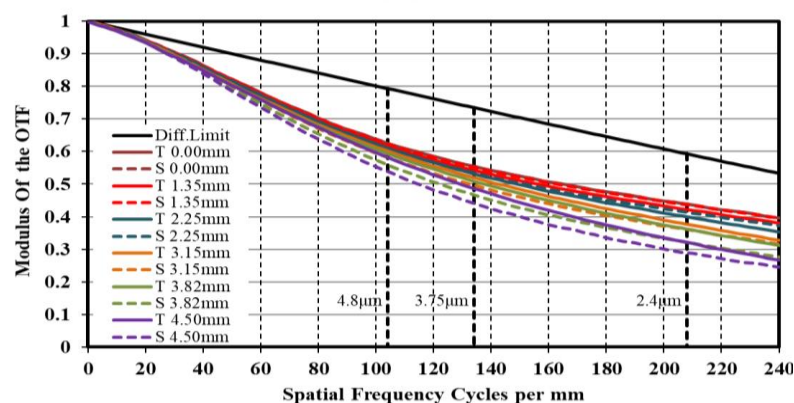

Relative Illumination

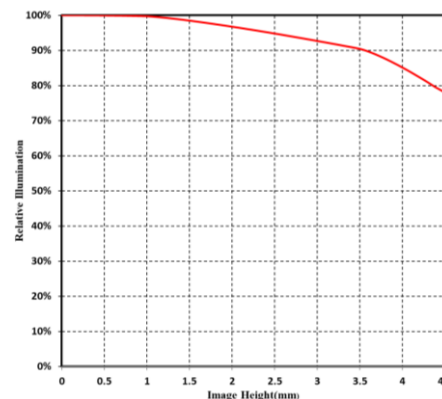

Note: The above curves are the simulate results based on F2.8, $\beta = -0.0492$, WD=500 mm.



Specification

Model	MVL-HF2528M-6MPE
Parameter	Fixed focal length, Manual iris, 6MP, FA Lens
Performance	
Focal Length	25 mm
F-Number	F2.8 ~ F16
Image Size	Φ9 mm(1/1.8")
Distortion	-0.028%
Minimum Object Distance	0.2 m
Field of View	D (8.96mm): 20.32° H (7.38mm): 16.77° V (4.92mm): 11.24°
Mechanical	
Iris Control	Manual
Focus Control	Manual
Filter Thread	M27 × P0.5
Mount	C-Mount
Flange Back Length	17.526 mm
Dimension	Φ33 × 30.22 mm
Weight	48.1 g
Temperature	-10 ~ 50°C
General	
Certification	RoHS2.0

Dimension

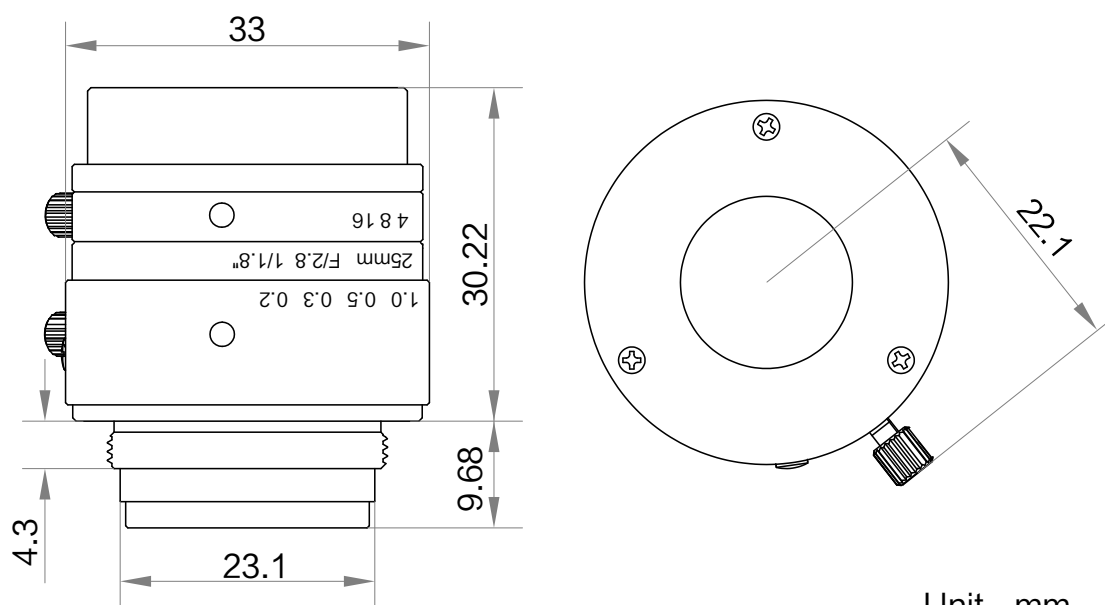

Unit: mm

Field of View

Extension (mm)	Working Distance (mm)		Magnification	Field of View (mm)			
				1/1.8"		1/2"	
				H(7.38mm)	H(4.92mm)	H(6.22mm)	V(4.67mm)
10	near	50	-0.567	13.09	8.70	11.02	8.26
	far	73	-0.379	19.68	13.05	16.54	12.38
5	near	75	-0.343	21.64	14.39	18.21	13.66
	far	143	-0.190	39.12	26.01	32.92	24.68
2	near	118	-0.208	35.65	23.72	30.01	22.51
	far	352	-0.076	97.25	64.81	81.95	61.51
1	near	147	-0.163	45.50	30.29	38.32	28.74
	far	700	-0.038	193.96	129.38	163.52	122.81
0		200	-0.209	62.95	49.58	59.64	47.08
		250	-0.173	77.91	59.71	71.82	56.70
		300	-0.147	92.63	70.44	84.73	66.90
		350	-0.128	107.20	81.17	97.64	77.09
		400	-0.113	121.65	91.91	110.55	87.29
		450	-0.083	136.02	124.12	149.30	117.88
		500	-0.077	150.32	134.86	162.22	128.08
		550	-0.071	164.57	145.59	175.13	138.27
		600	-0.066	178.78	156.33	188.05	148.47
		650	-0.062	192.95	167.07	200.97	158.67
		700	-0.058	207.10	177.81	213.88	168.87
		800	-0.055	235.32	188.54	226.80	179.07
		900	-0.052	263.47	199.28	239.72	189.27
	1000	-0.049	291.56	210.02	252.63	199.46	

HIKROBOT

Hangzhou Hikrobot Co. Ltd.
 en.hikrobotics.com

© Hangzhou Hikrobot Co., Ltd. All Rights Reserved.

Hangzhou Hikrobot does not tolerate any infringement. Any organization or individual may not imitate or reproduce in whole or in part of the content. The data herein is based on Hikrobot's internal evaluation. Actual data may vary depending on specific configuration and operating condition. The information herein is subject to change without notice. All the content has been checked conscientiously. Nevertheless, Hikrobot shall not be liable to damages resulting from errors, inconsistencies or omissions.