

# SCARA ROBOT THL700



Model		THL700
Type	Horizontal multi-joint	
No. of controlled axes	4	
Arm length	700mm (400mm+300mm)	
Working envelope	Axis 1	±125°
	Axis 2	±145°
	Axis 3 (Z axis)	0~150mm
	Axis 4 (Z-axis rotation)	±360°
Maximum speed*1	Axis 1	450°/s
	Axis 2	450°/s
	Axis 3 (Z axis)	2000mm/s
	Axis 4 (Z-axis rotation)	1700°/s
	Composite	7.9m/s
Standard cycle time (with 2 kg load)*2	0.50s	
Maximum payload mass	10kg (rated: 2kg)	
Allowable moment of inertia	0.2kg·m <sup>2</sup>	
Positioning repeatability*3	X-Y	±0.01mm
	Z (Axis 3)	±0.015mm
	Axis θ (Z-axis rotation)	±0.007°
Hand wiring	8 inputs / 8 outputs	
Hand pneumatic joints*4	φ6 x 3 pcs.	
Position detection	Absolute	
Robot controller cable	3.5m	
Power capacity	1.4kVA	
Mass	24kg	

■For \*1 to \*4, please see page 5.

# SCARA ROBOT THL800



Model		THL800
Type	Horizontal multi-joint	
No. of controlled axes	4	
Arm length	800mm (350mm+450mm)	
Working envelope	Axis 1	±125°
	Axis 2	±145°
	Axis 3 (Z axis)	0~300mm
	Axis 4 (Z-axis rotation)	±360°
Maximum speed*1	Axis 1	187.5°/s
	Axis 2	217.5°/s
	Axis 3 (Z axis)	2000mm/s
	Axis 4 (Z-axis rotation)	1700°/s
	Composite	4.3m/s
Standard cycle time (with 2 kg load)*2	0.47s	
Maximum payload mass	10kg (rated: 2kg)	
Allowable moment of inertia	0.2kg·m <sup>2</sup>	
Positioning repeatability*3	X-Y	±0.02mm
	Z (Axis 3)	±0.015mm
	Axis θ (Z-axis rotation)	±0.007°
Hand wiring	8 inputs / 8 outputs	
Hand pneumatic joints*4	φ6 x 3 pcs.	
Position detection	Absolute	
Robot controller cable	3.5m	
Power capacity	1.4kVA	
Mass	33kg	

■For \*1 to \*4, please see page 5.

## External view

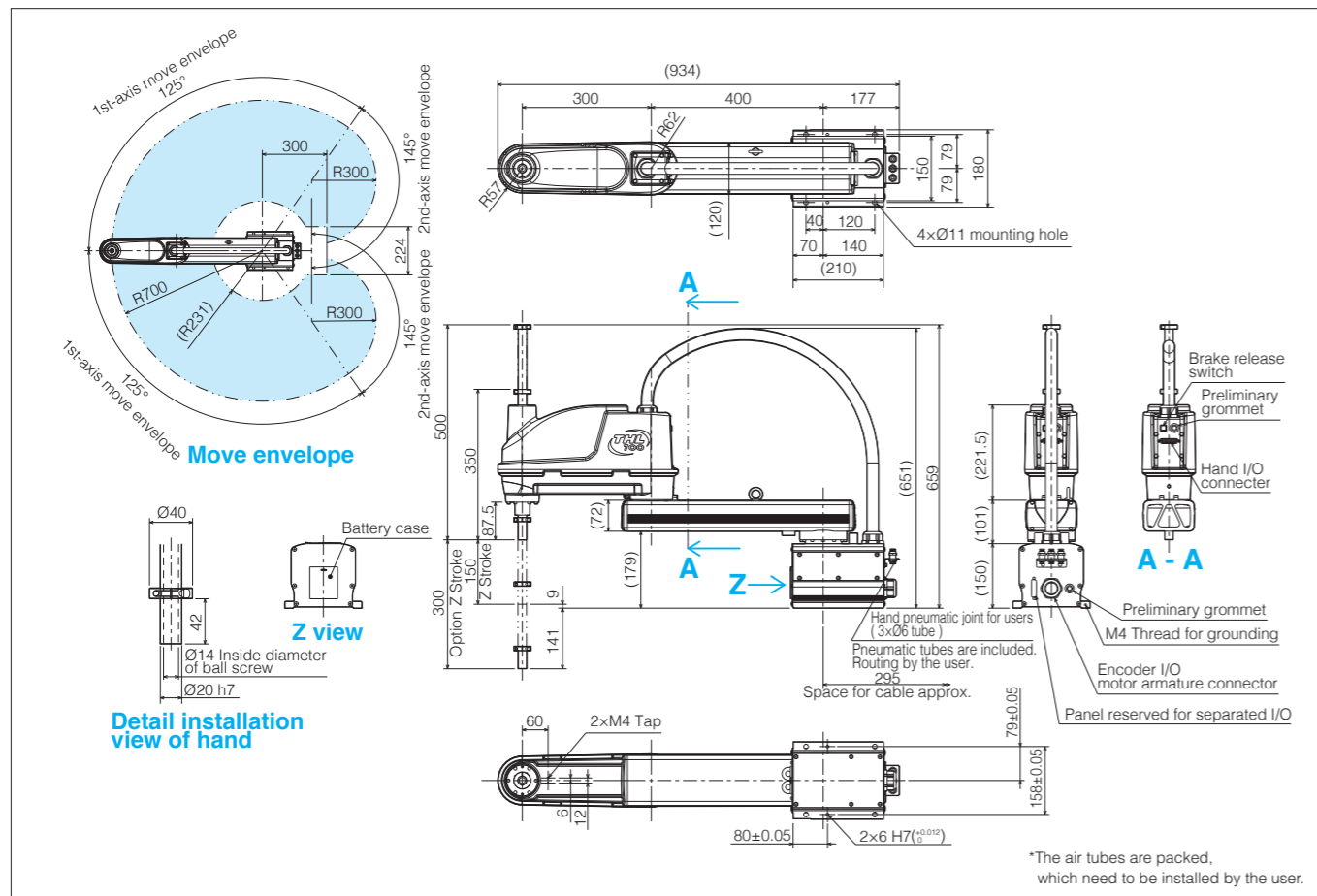

## External view

