

microDAQ3

64 Channel Advanced Pressure Scanner

- **New and advanced use of digital sensor technology.**
- **Unparalleled Data Quality: up to 0.02% of full scale**
- **High speed : 400Hz per channel**
- **Absolute and differential measurements**
- **Optional electrically driven valve for purge and re-zero**
- **Complete with IEEE 1588 PTPv2 time stamping**
- **Thermally compensated from -20 to 90°C**
- **24 bit ADC per channel**
- **Output over Ethernet (100Mbit TCP / UDP) and CAN**
- **Available with quick-disconnect top plate**
- **Fully configurable over Ethernet with embedded web server**

The Chell microDAQ3 is a leap forward in pressure scanning technology. The use of high accuracy digital sensors combined with an advanced processor design results in the most accurate - and most versatile pressure scanner on the market.

The microDAQ3 will output differential or absolute compensated engineering unit pressure data over Ethernet, CAN, IENA, and EtherCAT (see microCAT3) at speeds up to 400Hz per channel.

The microDAQ3 offers the option of an electrically driven valve that gives the scanner a purge and re-zero facility. The valve has been years in development and features precise positional measurement and current monitoring to ensure reliability.

The microDAQ3 is also the smallest digital pressure scanner on the market - even when fitted with the electrically driven valve. The non-valved option gives the user a further reduction in size when purge is not required.

The microDAQ3 makes use of high accuracy transducers which are combined with two 24-bit ADC's per port - one for pressure and one for temperature. This precise temperature measurement allows the MicroDAQ3 to almost entirely compensate for thermal effects over its wide operating range.

The microDAQ3 makes use of all the technology that Chell has developed with its MicroDAQ and nanoDAQ range such as embedded web server, IEEE 1588 PTP time stamping, power-over-ethernet, CAN, hardware trigger and EtherCAT (see MicroCAT3).

General

Differential ranges available	1, 2.5, 5, 7, 10,17, 35, 55, 103, 207 and 310 kPa
Number of channels	64
Maximum Acquisition Speed (measurements / channel / second)	400 (200Hz for single message CAN mode)

Data Output

Output types	CAN and Ethernet (TCP/IP & UDP), IENA
Ethernet Specification	100Mbit TCP/IP or UDP (user configurable)
CAN Specification	2.0B

Performance

System Accuracy	See table below
Absolute Ranges	160 kPa and 400 kPa
Calibrated absolute pressure range for differential range \leq 55 kPa (8 psid)	0.5 kPa to 160 kPa (0.07 psia to 23.2 psia)
Calibrated absolute pressure range for differential ranges between 103 kPa (15 psi) and 300 kPa (43.5 psid)	0.5 kPa to 400 kPa (0.07 psia to 58 psia)
Line pressure limitation	None - as long as all measured pressures are within above pressures
Proof Pressure (all ranges)	689kPa (100 psig)
Output Resolution	16 bit or \pm range / 65536
System Resolution	24 bit

Mechanical

Valved version Dimensions width x depth x height in mm)	80 x 39 x 34 excluding tubulations
Non-valved version Dimensions (width x depth x height in mm)	80 x 39 x 27 excluding tubulations
Weight (Valved / non-valved)	205g / 157g
Enclosure Sealing	IP54
Measurement ports	1.0 mm (0.04") bulged tubulations
Purge ports (valved version only)	2.3 mm (0.09") bulged tubulation
Maximum purge pressure	10 bar gauge
Purge Flow	22 SLPM at 1 bar purge, 46 SLPM at 2 bar purge and 66 SLPM at 3 bar

Power Supply

Input supply	8-30 VDC
Power consumption	1W (non-valved), 4W (valved)
Electrical Connector (micro miniature 'D' type)	Female 9-way micro-miniature 'D' type (suggested mate : Glenair MWDM2L-9PS - solder cup version)
Electrical Connector (Souriau 8STA)	Souriau 8STA-06-9PN

Environment

Operating Temperature Range	-40 to +90°C
Compensated Temperature Range	0 to +90°C (optional -20 to +90°C)
Storage Temperature Range	-40 to +90°C
Ambient Pressure	5 mbar abs to 2.5 bar abs
Vibration	Engine standard vibration test to DO160E category S, curve W with duration of 1 hr/axis. Fan blade (20 g 2 kHz)
Shock	Fan blade out to DO160F section 7 (40g 11 m/s)
Maximum relative humidity	95% at 50°C (non-condensing)

Timing / Data Synchronisation

Time Stamping	IEEE 1588 PTPv2
Time Stamping Resolution	1 μ s
Hardware Trigger	5 V TTL pulse, maximum 400 Hz, minimum 2 Hz

microDAQ3 Accuracy - A Metrology Approach

The performance and flexibility of the microDAQ3 calls for a detailed and transparent approach to specifying its accuracy. The table below details the resolution, standard deviation and errors with 95% confidence (2 x sigma). The error figure below includes all the contributions from:

- Limit of accuracy (linearity)
- Repeatability
- Stability (noise)
- Long term drift (12 months)
- Thermal errors from 0 to 90°C (optionally -20 to 90°C)
- Resolution limitations
- Line pressure effects

For more details on how the performance specifications are derived, please see our application notes on the subject.

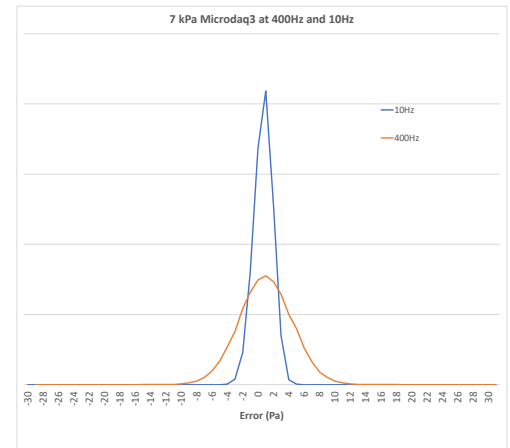

Differential Ranges

Differential Range (+/-) ¹	Max Absolute Range ²	Output Resolution (Pa)	Standard Deviation (Pa) ³	Error (95% Confidence)		
				±Pa	%FS ⁴	
1 kPa	4" water	0.5 to 175kPa	0.03	0.91	1.82	0.2%
2.5 kPa	10" water	0.5 to 175kPa	0.08	0.91	1.82	0.07%
5 kPa	20" water	0.5 to 175kPa	0.15	0.91	1.82	0.04%
7 kPa	1 psi	0.5 to 175kPa	0.21	1.1	2.26	0.03%
10 kPa	1.5 psi	0.5 to 175kPa	0.31	1.25	2.5	0.03%
17 kPa	2.5 psi	0.5 to 175kPa	0.52	1.5	3.0	0.02%
35 kPa	5 psi	0.5 to 175kPa	1	2.01	7.0	0.02%
55 kPa	8 psi	0.5 to 175kPa	1.7	1.71	11	0.02%
-83 kPa to 103 kPa	-12 to 15 psi	0.5 to 400 kPa	3.15	3.0	20	0.02%
-83 kPa to 207 kPa	-12 to 30 psi	0.5 to 400 kPa	6.3	5	40	0.02%
-83 kPa to 300k Pa	-12 to 43.5 psi	0.5 to 400 kPa	9.5	9.0	60	0.02%

For 100 and 150 psi ranges, see 32MD3-HP

1) Differential range assumes a reference of 1 bar. Reference pressure can vary as long as all measurements are within the Max Absolute Range² of the transducers.
 2) Max absolute range of the transducers.
 3) Data collected at 100Hz with an average of 16.
 4) %FS values refer to the percentage of the differential range as listed. See above for error definition.

Absolute Ranges

Absolute Range	Output Resolution (Pa)	Standard Deviation (Pa) ¹	Error (95% Confidence)		
			±Pa	%FS ²	
Absolute range for differential ranges up to 55 kPa (8 psi)					
0.5 to 160 kPa	0.07 psia to 23.2 psia	2.24 ³	1.6	30	0.02%
Absolute range for differential ranges of 103, 207 and 300 kPa (15, 30 and 43.5 psi)					
0.5 to 400 kPa	0.07 psia to 58.01 psia	6.1 ³	6	60	0.02%

1) Data collected in accuracy mode with an average of 16
 2) %FS values refer to the percentage of the maximum absolute values as listed.
 3) Absolute range can be user configured to improve resolution.

Absolute Transducers - More information and better performance

The microDAQ3 is available with two ranges of absolute sensors; 160kPa and 400 kPa absolute which are used for both the measurement and reference ports. The microDAQ3s are calibrated over their full absolute range (see above) and the absolute output can be configured to suit the use case and optimise the resolution of the 16-bit output.

For differential outputs, the two reference ports (they can be used individually or averaged together) are subtracted from the measurement ports to provide a differential output. The microDAQ3's are purchased pre-configured for a particular differential range to maximise the resolution of the 16-bit output. Line pressures can be accommodated as long as the range of pressures measured falls within the absolute range of the sensors.

The use of absolute transducers in the microDAQ3 leads to several advantages:

- The ability for the user to switch between differential and absolute measurements.
- High accuracy and low noise measurement with the digitisation of the pressure and temperature signal at the transducer.
- Improved thermal performance with no dependence on ADC or sensor excitation thermal coefficients.
- The ability to output differential measurements **and** the absolute value of the reference removing the need for external barometric transducers.
- The option to output absolute values for all channels and thereby removing the need for a reference all together.
- The lack of an internal reference cavity (and therefore volume) means the scanner responds much faster to changes in reference pressure (for example, changes in altitude) improving data quality.

Digital Transducers - A revolution in data quality

The digital transducers used in the microDAQ3 provide unparalleled data quality. When the pressure and temperature output for each transducer are processed with our proprietary thermal compensation routine, the results set a new standard for pressure scanners and a considerable improvement over the microDAQ2 product range.

The histogram opposite shows a 15 psid microDAQ3 when compared to the data from a microDAQ2 which incorporate a digitally thermally compensated (DTC) scanner using conventional analogue transducers.

The microDAQ3 produces superior data to conventional compensated scanners - even when the older scanners are used with on-line calibration!

This performance removes the need for on-line calibration and, in most cases, rezero.

The Purge Valve

We have been developing the new purge valve for the last few years. To remove the need to supply pneumatic pressures to the scanner, the new valve is electrically driven by a precision high-torque motor and gearbox. The valve is controlled to a position (measured to 5 µm) and the current consumed by the motor to ensure reliable, repeatable performance.

The valve has been rigorously tested to 10,000 cycles and features a cycle count so that any necessary maintenance can be planned.

The purge flow through the valve has been characterised over a pressure range (see table above) and provides a greater flow than scanners offered elsewhere.

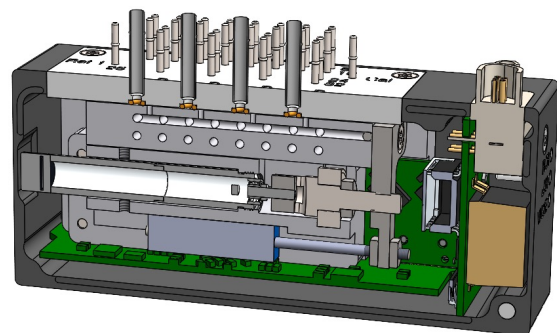
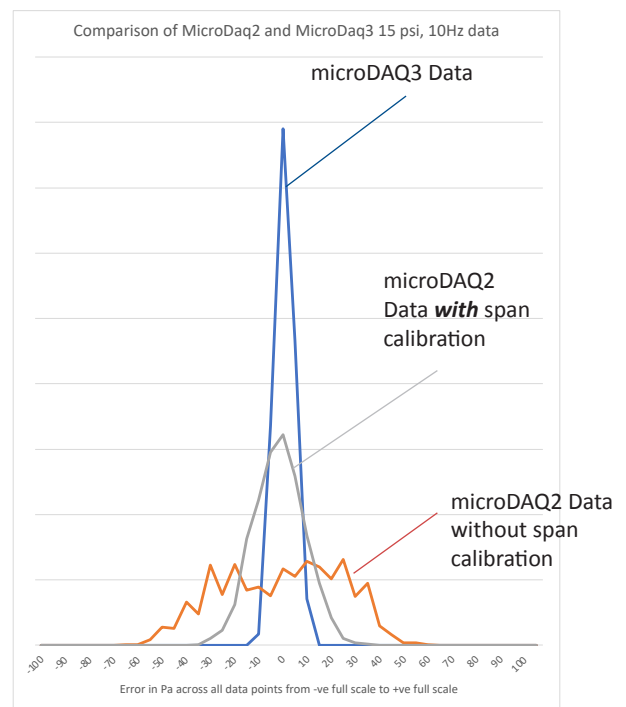

Dimensions - Valved Version (BB=01)

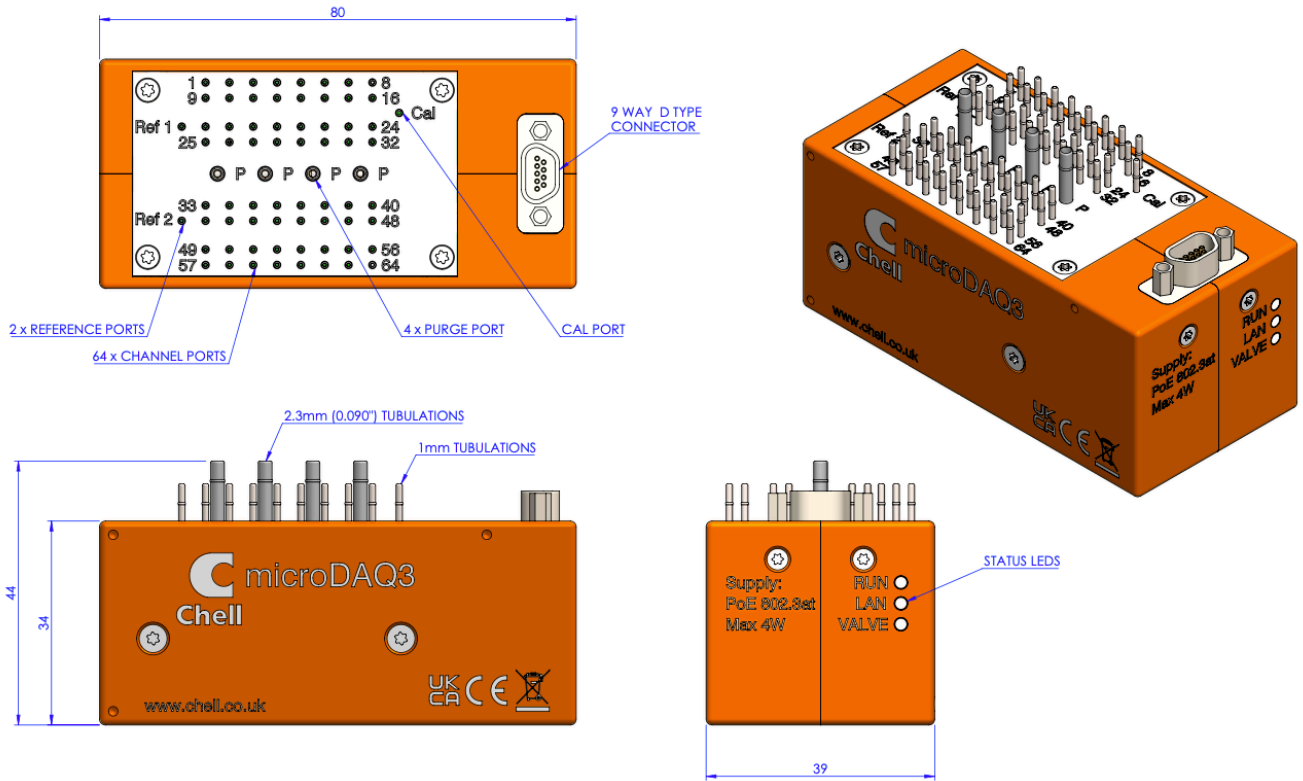

Dimensions - Non-Valved Version (BB=02)

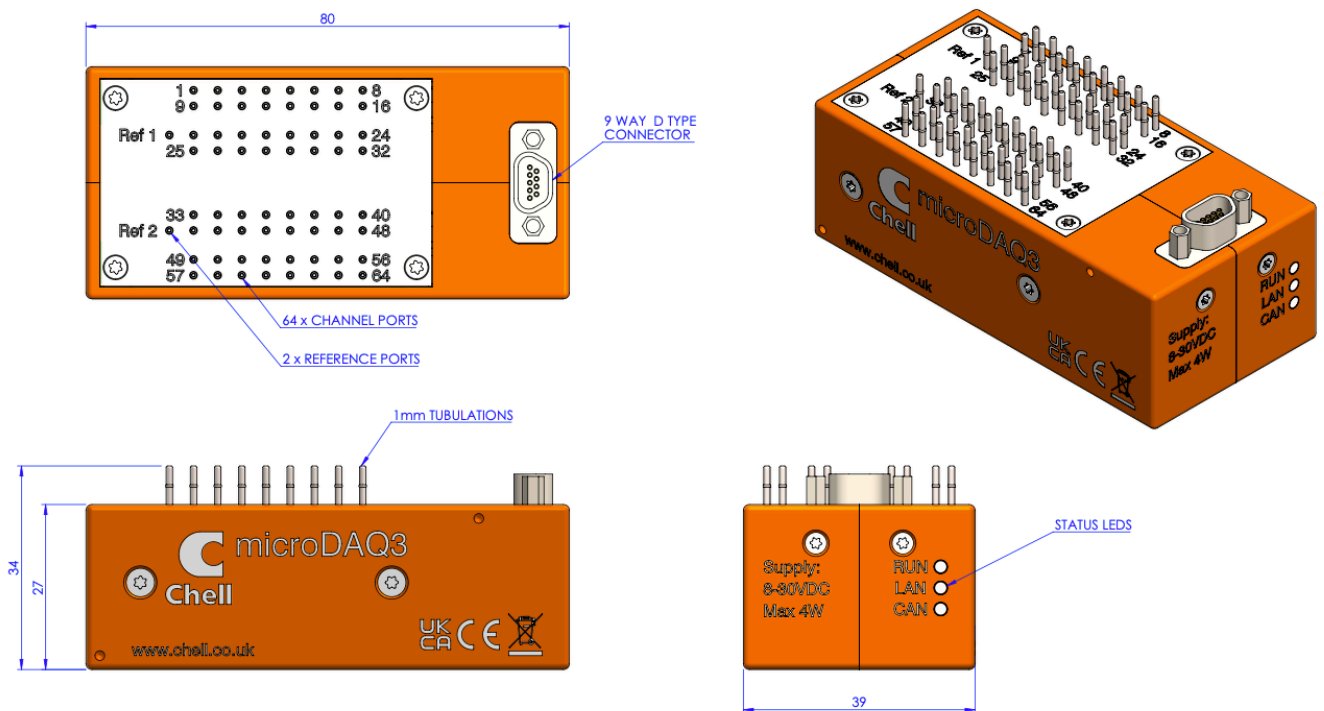

The Quick Disconnect Option

Both the valved and non-valved versions of the microDAQ3 are available with a quick disconnect option. Here the tubulation plate is removable and can be easily exchanged for another meaning the scanner can be moved between distinct sets of tubing.

The quick disconnect options comes as a set of four plates (intermediate, tubulation and 2 x protector plates). Additional tubulation plates and protector plates can be ordered individually.

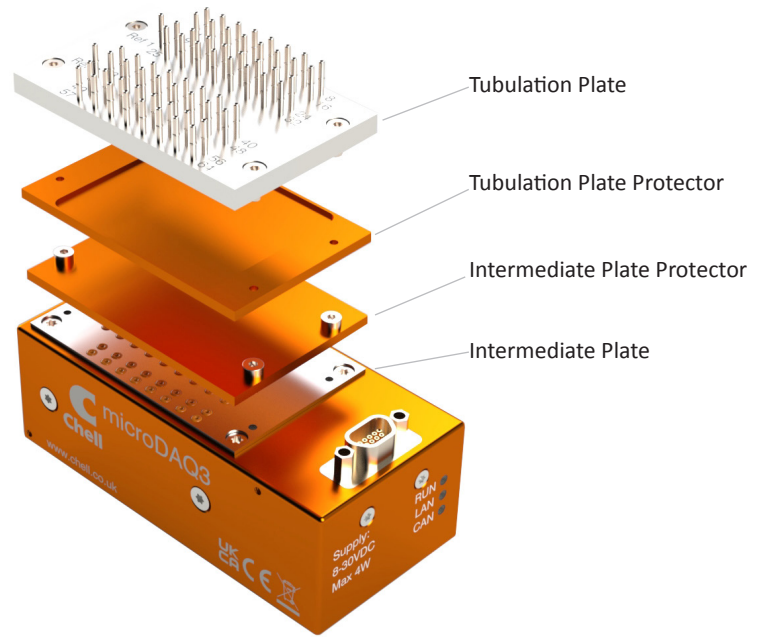

Dimensions - Valved Version with QDC Option (BB=03)

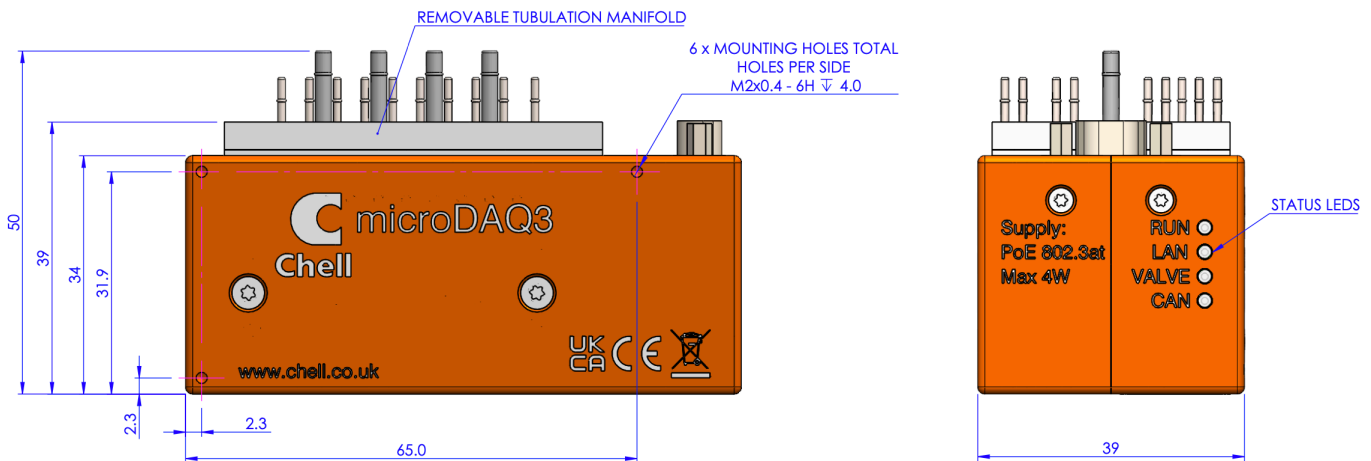

Dimensions - Non-Valved Version with QDC Option (BB=04)

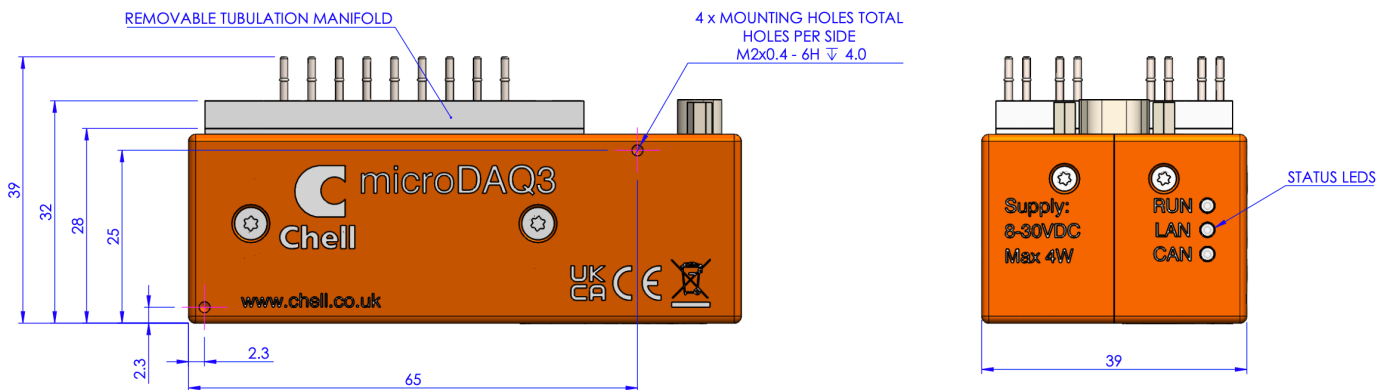

**Dimensions -
Non-valved QDC version (BB=04)
8STA connector (CC=03)**

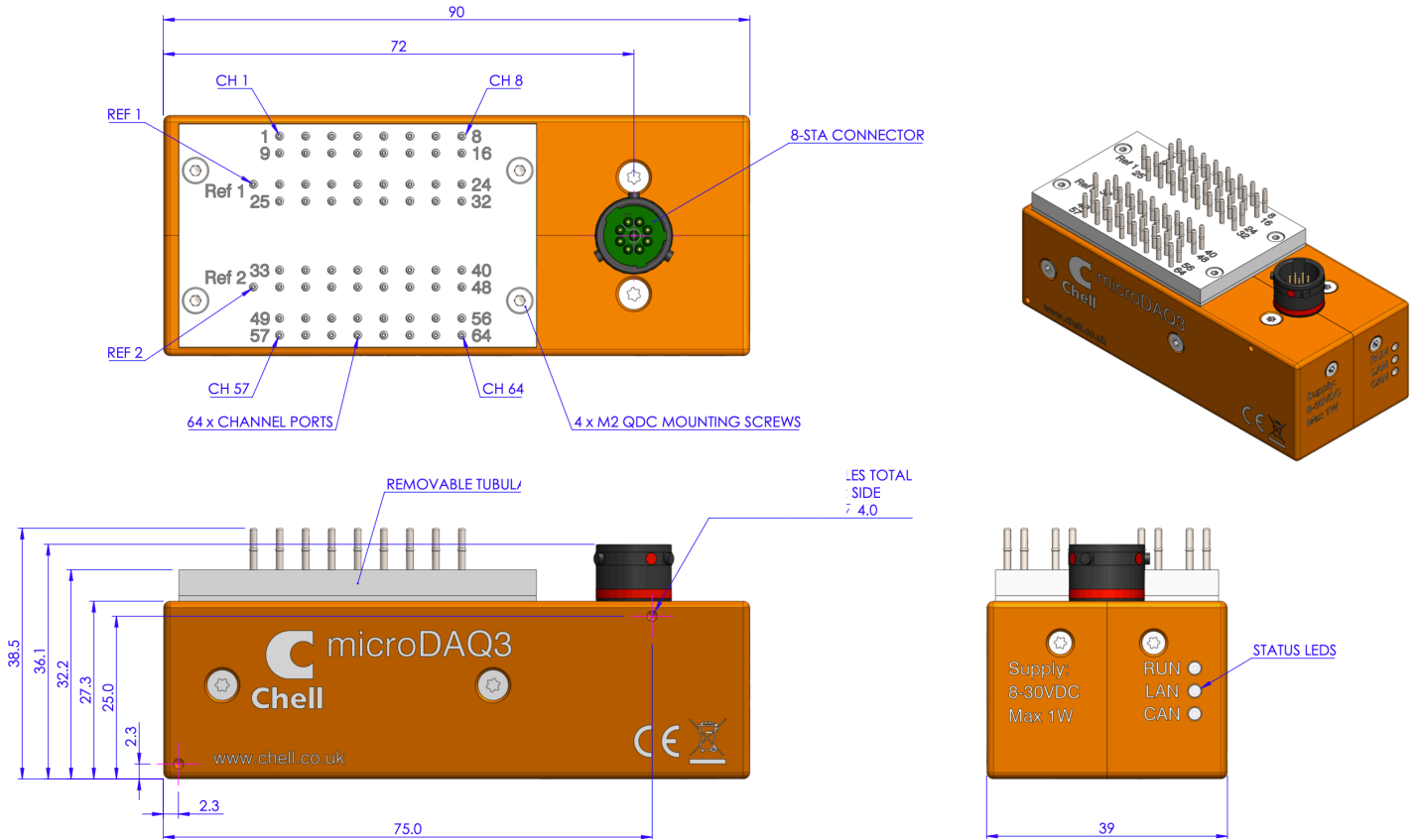

Part Number:

64MD3 -AABBCCDD

AA = Range

- 01 = 1 kPa (4" water)
- 02 = 2.5 kPa (10" water)
- 03 = 5 kPa (20" water)
- 04 = 7 kPa (1 psi)
- 05 = 10 kPa (1.5 psi)
- 06 = 17 kPa (2.5 psi)
- 07 = 35 kPa (5 psi)
- 08 = 55 kPa (8 psi)
- 09 = 103 kPa (15 psi)
- 10 = 207 kPa (30 psi)
- 11 = 300 kPa (43.5 psi)

BB = Valve

- 01 = With valve and 1 mm tubulations (2.3 mm for purge tubulations)
- 02 = Without valve and 1 mm tubulations
- 03 = With valve and quick disconnect top plate
- 04 = Without valve and quick disconnect top plate
- 05 = With valve and quick disconnect intermediate plate and protector only
- 06 = Without valve and quick disconnect intermediate plate and protector only

DD = Calibrated Temperature Range

- 01 = 0 to 90°C
- 02 = -20 to 90°C

CC = Interface / Supply

- 02 = DC supply with CAN and hardware trigger (female miniature 'D' type connector)
- 03 = DC supply with CAN and hardware trigger (8STA Autosport connector)

- 81 = Mixed range, 2 ranges (each 32 channels). Range codes 01 to 08 inclusive
- 82 = Mixed range, 4 ranges (each 16 channels). Range codes 01 to 08 inclusive
- 91 = Mixed range, 2 ranges (each 32 channels). Range codes 09 to 11 inclusive
- 92 = Mixed range, 4 ranges (each 16 channels). Range codes 09 to 11 inclusive