

# MV-SC6050M-00C-NNN

## 5 MP Smart Camera



### Introduction

MV-SC6000 smart camera is developed based on high-performance embedded platform with strong calculation performance. It integrates VM functions and AI deep learning algorithm, and can use more than 140 algorithms. It adopts multiple interfaces for supporting external light source, display, mouse, etc.

### Available Model

MV-SC6050M-00C-NNN

### Applicable Industry

Consumer electronics, food and pharmaceutical, packaging, positioning and grabbing, etc.

### Key Feature

- Adopts AI deep learning algorithm to achieve OCR, object recognition, defect detection, etc.
- Integrates VM functions and supports more than 140 algorithms.
- Adopts multiple interfaces and supports multiple-channel I/O, light source, display, etc.
- Adopts high-performance CPU with faster calculation performance and high efficiency.
- Supports multiple communication protocols.
- Supports indicators displaying device status for easy debugging and maintenance.
- Supports ingress protection IP67.

### Dimension

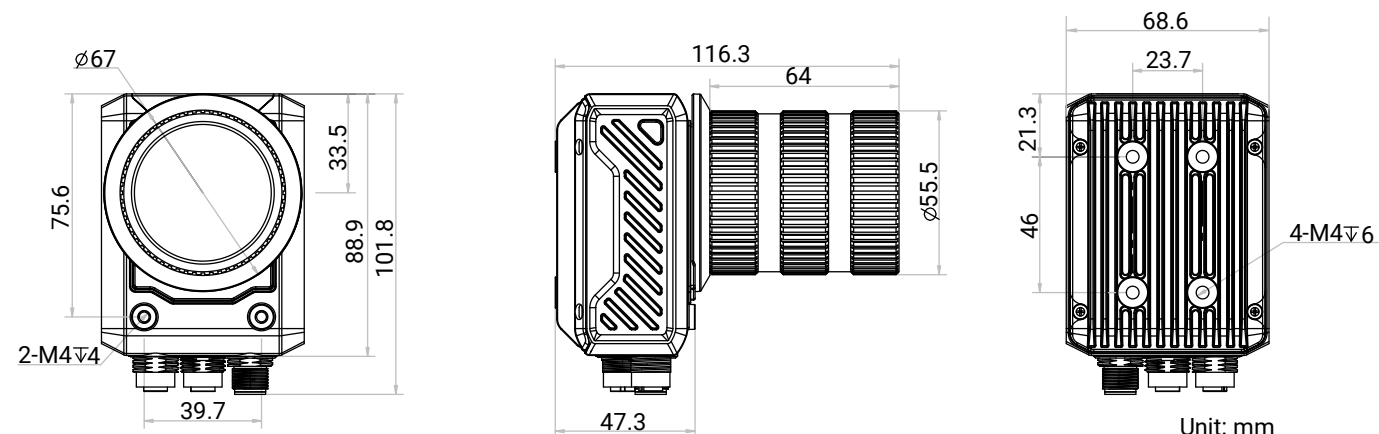

## Specification

<b>Model</b>	<b>MV-SC6050M-00C-NNN</b>
<b>Tool</b>	
<b>Function module</b>	VM Platform
<b>Communication protocol</b>	TCP, UDP, ModBus, Serial Port, Profinet, EtherNet/IP, Fins, MC, FTP, etc.
<b>Camera</b>	
<b>Sensor type</b>	CMOS, global shutter
<b>Pixel size</b>	3.2 $\mu\text{m}$ $\times$ 3.2 $\mu\text{m}$
<b>Sensor size</b>	1/1.7"
<b>Resolution</b>	2560 $\times$ 2048
<b>Max. frame rate</b>	40 fps
<b>Gain</b>	0 dB to 18 dB
<b>Exposure time</b>	16 $\mu\text{s}$ to 1 sec
<b>Pixel format</b>	Mono 8
<b>Mono/color</b>	Mono
<b>Platform</b>	
<b>Memory</b>	8 GB
<b>Storage</b>	64 GB
<b>Electrical feature</b>	
<b>Data interface</b>	Gigabit Ethernet
<b>Digital I/O</b>	17-pin M12 male connector provides power and I/O, providing opto-isolated input $\times$ 2 (Line 0/1), opto-isolated output $\times$ 2 (Line 4/5), configurable non-isolated input/output $\times$ 2 (Line 2/3), RS-232 $\times$ 1, light source output (max. 30 W) $\times$ 1
<b>Extended interface</b>	17-pin M12 female connector provides VGA $\times$ 1 and USB host $\times$ 1
<b>Power supply</b>	24 VDC
<b>Power consumption</b>	Approx. 12.5 W @24 VDC (without external light source) Approx. 42.5 W @24 VDC (with external light source)
<b>Mechanical</b>	
<b>Lens mount</b>	C-mount
<b>Lens cap</b>	Transparent lens cap
<b>Light source</b>	Not included
<b>Indicator</b>	Power indicator (PWR), network indicator (LNK), status indicator (STS), and user-defined indicator (U1/U2)
<b>Dimension</b>	116.3 mm $\times$ 68.6 mm $\times$ 101.8 mm (4.6" $\times$ 2.7" $\times$ 4.0")
<b>Weight</b>	Approx. 530 g (1.2 lb.)
<b>Ingress protection</b>	IP67 (under proper installation of waterproof lens cap)
<b>Temperature</b>	Working temperature: 0 $^{\circ}\text{C}$ to 50 $^{\circ}\text{C}$ (32 $^{\circ}\text{F}$ to 122 $^{\circ}\text{F}$ ) Storage temperature: -30 $^{\circ}\text{C}$ to 70 $^{\circ}\text{C}$ (-22 $^{\circ}\text{F}$ to 158 $^{\circ}\text{F}$ )
<b>Humidity</b>	20% to 95% RH, non-condensing
<b>General</b>	
<b>Certification</b>	CE, KC