



Features:

- High-reliability non-contact rotary torque measurements
- Five unique rated capacities and mounting configurations
- Low inertia & high stiffness
- On-board shunt calibration circuit
- Rated speed 20,000 RPM (35,000 RPM optional)
- Optional zero velocity speed sensor
- Optional interconnecting cable assemblies
- Optional i200 AC carrier electronics (i200)
- SAE 4340 alloy steel with satin nickel finish

The SensorData Technologies Model T260 Series is a family of rotary transformer coupled torque sensors. They are designed for both viscosity measurements and the inline testing of motors, engines, transmissions, propellers, pumps, drivelines, and similar rotating devices. Available in five unique rated capacities and mounting configurations, the Model T260 Series offers 20% to 40% greater stiffness and 4x to 6x less rotating inertia, at 1/3 of the size of comparable industry models. The Model T260 Series requires the use of AC carrier strain gage signal conditioning electronics, such as the SensorData i200. An optional zero velocity speed sensor is installed inside the T260 housing. Interconnecting cable assemblies are an available option. SensorData will provide in-house calibration of the T260 with customer-supplied electronics for a fee. Customized versions of the Model T260 Series are also available. Please consult the factory for details.

PRODUCT REFERENCE SPECIFICATIONS

Rated Capacity (lb-in)	100, 200, 500, 1K, 2K
Rated Speed (RPM)	20,000 (35,000 optional)
Nonlinearity	±0.05% of rated output
Hysteresis	±0.05% of rated output
Nonrepeatability	±0.02% of rated output
Rated Output, Bridge, Typical	2 mV/V
Zero Balance	±0.5% of rated output
Temperature Range, Operating	-20 to +200°F
Temperature Range, Compensated	+68 to +170°F
Temperature Effect on Output	0.001% of load/F
Temperature Effect on Zero	0.001% of rated output/F
Bridge Resistance, typical	350 ohms
Excitation	2.8 to 5 VAC rms, 3 kHz to 5 kHz
Insulation Resistance, Bridge to Case	>5000 megohms at 50 VDC
Input Voltage, Speed Sensor, V _{cc} (Optional)	4.5 to 24 VDC
⁽¹⁾ Maximum Load, Safe ⁽²⁾	200% of rated capacity
Maximum Load, ultimate ⁽³⁾	400% of rated capacity
Number of Bridges	1
Weight (lbs) with (without) i200	4 (5)
Construction	SAE 4340 alloy steel [with satin nickel finish]

Notes:

(1) Output is an open collector NPN with internal 4.7K ohm pull up resistor

(2) With load centered, maximum torque that can be applied without producing a permanent shift in performance characteristics.

(3) With load centered, maximum torque that can be applied without physical damage.

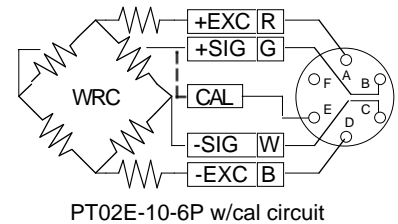
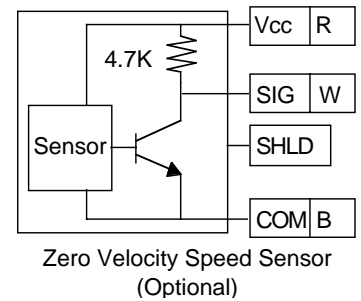
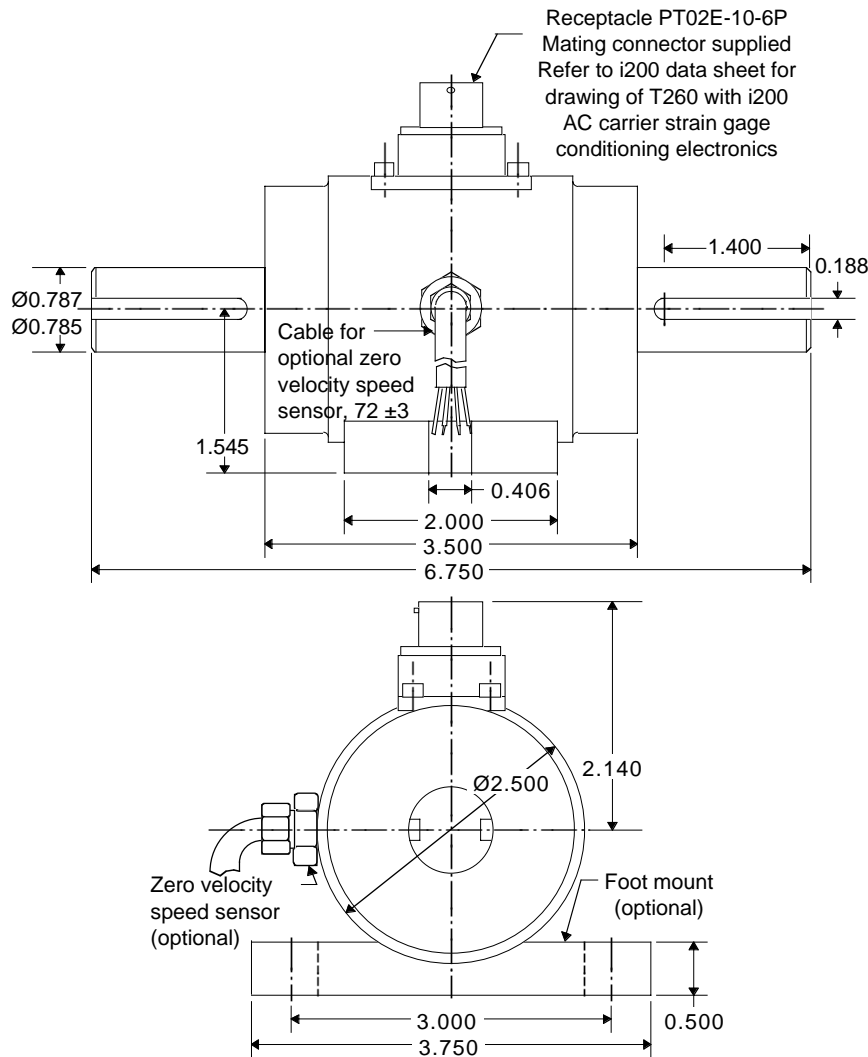

Capacity (lb-in)	Torsional Stiffness lb-in/rad	Rotating lb-in-sec ²
100	34 x 10 ³	6.6 x 10 ⁻⁴
200	39 x 10 ³	6.6 x 10 ⁻⁴
500	54 x 10 ³	6.6 x 10 ⁻⁴
1000	85 x 10 ³	6.6 x 10 ⁻⁴
2000	95 x 10 ³	6.6 x 10 ⁻⁴

If the T260 is supplied with the optional SensorData i200 AC carrier strain gage conditioning electronics, the i200 instruction manual or data sheet should be referred to for wiring information and specifications.

ORDERING INFORMATION

T260-STD-Capacity	Standard with receptacle and mating connector
T260-STD-Capacity-A	Same as T260-STD-Capacity except supplied with SensorData i200 strain gage conditioning electronics.
T260-STD-Capacity-S	Same as T260-STD-Capacity except supplied with zero velocity speed sensor.
T260-STD-Capacity-S-A	Same as T260-STD-Capacity except with zero velocity speed sensor & i200 strain gage conditioning electronics.
Foot Mount Option	Replace STD with 105 in above model designations; e.g., T260-105-Capacity-S-A
35,000 RPM Option	Replace STD with 111 in above model designations; e.g., T260-111-Capacity-S-A. Not available with foot mount.
Cable Assembly	Optional; 10 ft., color coded, shielded, mating connector sensor end, customer specified connector instrument end.
Cable Assembly	Optional; 10 ft., color coded, shielded, mating connector sensor end, leads stripped and tinned instrument end.

Note: Mounting hardware is optional and not included unless specified at time of order

IMPORTANT NOTICES

Dimensions are in inches unless otherwise noted. Manufacturer not responsible for any modifications to product, fixtures, or accessories made by any user or third party, without exception. User should request certified drawings before designing mountings or fixtures. Manufacturer reserves the right to modify or change its product design, dimensions, specifications, and features without prior written notice. Changes to NOTICE must be in writing and accepted by manufacturer