

# MV-CS050-90GM/GC

## 5 MP CMOS GigE Area Scan Camera



**GEN<i>i</i>CAM**

**GigE VISION**

### Introduction

MV-CS050-90GM/GC camera adopts GMAX3405 CMOS sensor to provide high-quality images and transmit images in real time, and its max. frame rate can reach 24.2 fps in full resolution.

### Key Feature

- Adopts brand new design to reduce power consumption.
- Supports auto or manual adjustment for gain, exposure control, white balance, contrast ratio, Gamma correction, etc.
- Compact design with mounting holes on panels for flexible mounting from 4 sides.
- Adopts GigE interface and max. transmission distance of 100 meters without relay.
- Compatible with GigE Vision V2.0 Protocol, GenICam Standard, and third-party software based on the protocol and standard.

### Dimension

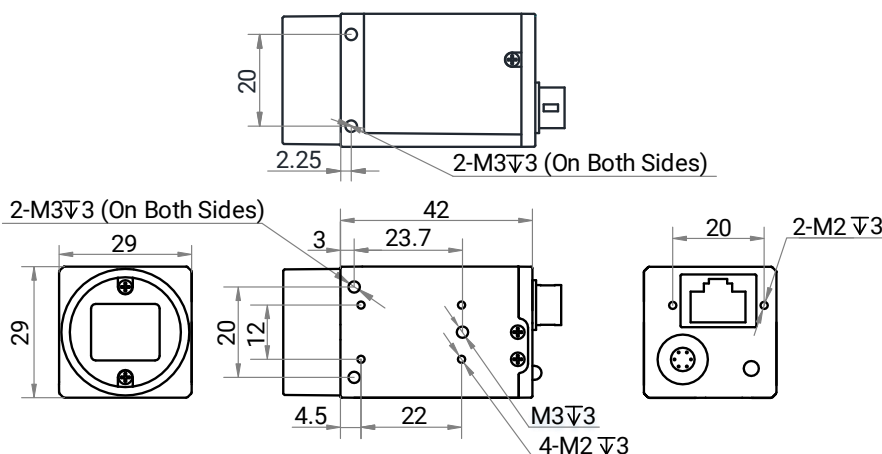

Unit: mm

### Available Model

- Mono camera: MV-CS050-90GM
- Color camera: MV-CS050-90GC

### Applicable Industry

Electronic semiconductor, factory automation, food and beverage, medicine packaging, etc.

### Sensor Quantum Efficiency

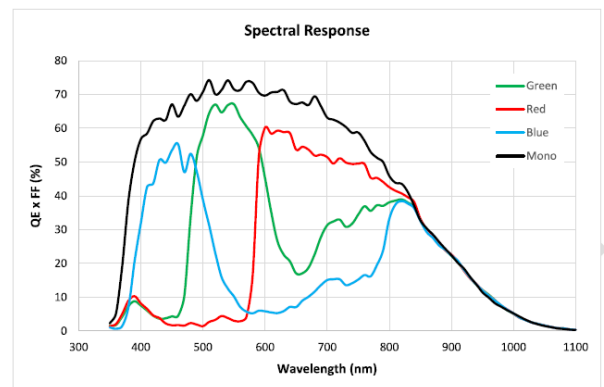

## Specification

Model	MV-CS050-90GM	MV-CS050-90GC
<b>Camera</b>		
<b>Sensor type</b>	CMOS, global shutter	
<b>Sensor model</b>	GMAX3405	
<b>Pixel size</b>	3.4 $\mu\text{m}$ $\times$ 3.4 $\mu\text{m}$	
<b>Sensor size</b>	2/3"	
<b>Resolution</b>	2448 $\times$ 2048	
<b>Max. frame rate</b>	24.2 fps @ 2448 $\times$ 2048 Mono 8	24.2 fps @ 2448 $\times$ 2048 Bayer GB 8
<b>Dynamic range</b>	66 dB	
<b>SNR</b>	39.4 dB	
<b>Gain</b>	0 dB to 24 dB	
<b>Exposure time</b>	UltraShort exposure mode: 2 $\mu\text{s}$ to 4 $\mu\text{s}$ Standard exposure mode: 5 $\mu\text{s}$ to 10 sec	
<b>Exposure mode</b>	Off/Once/Continuous exposure mode	
<b>Mono/color</b>	Mono	Color
<b>Pixel format</b>	Mono 8/10/10Packed/12/12Packed	Mono 8/10/12, Bayer GB 8/10/10Packed/12/12Packed, YUV422Packed, YUV422_YUYV_Packed, RGB 8, BGR 8
<b>Binning</b>	Supports 1 $\times$ 1, 2 $\times$ 2, 4 $\times$ 4	
<b>Decimation</b>	Supports 1 $\times$ 1, 2 $\times$ 2, 4 $\times$ 4	
<b>Reverse image</b>	Supports horizontal and vertical reverse image output	
<b>Electrical features</b>		
<b>Data interface</b>	Gigabit Ethernet (1000 Mbit/s), compatible with Fast Ethernet (100 Mbit/s)	
<b>Digital I/O</b>	6-pin P7 connector provides power and I/O, including opto-isolated input $\times$ 1 (Line 0), opto-isolated output $\times$ 1 (Line 1), bi-directional non-isolated I/O $\times$ 1 (Line 2).	
<b>Power supply</b>	9 VDC to 24 VDC, supports PoE	
<b>Power consumption</b>	Typ. 2.2 W @ 12 VDC	Typ. 2.3 W @ 12 VDC
<b>Mechanical</b>		
<b>Lens mount</b>	C-mount	
<b>Dimension</b>	29 mm $\times$ 29 mm $\times$ 42 mm (1.1" $\times$ 1.1" $\times$ 1.7")	
<b>Weight</b>	Approx. 100 g (0.2 lb.)	
<b>Ingress protection</b>	IP40 (under proper lens installation and wiring)	
<b>Temperature</b>	Working temperature: $-30$ $^{\circ}\text{C}$ to $60$ $^{\circ}\text{C}$ ( $-22$ $^{\circ}\text{F}$ to $140$ $^{\circ}\text{F}$ ) Storage temperature: $-30$ $^{\circ}\text{C}$ to $80$ $^{\circ}\text{C}$ ( $-22$ $^{\circ}\text{F}$ to $176$ $^{\circ}\text{F}$ )	
<b>Humidity</b>	20% RH to 95% RH (no condensation)	
<b>General</b>		
<b>Client software</b>	MVS or third-party software meeting with GigE Vision Protocol	
<b>Operating system</b>	32/64-bit Windows XP/7/10/11, 32/64-bit Linux, and 64-bit MacOS	
<b>Compatibility</b>	GigE Vision V2.0, GenICam	
<b>Certification</b>	CE, RoHS, KC	