



# SCM5B38

## Strain Gage Input Modules, Narrow Bandwidth

### Description

Each SCM5B38 Strain Gage input module provides a single channel of strain gage input which is filtered, isolated, amplified, and converted to a high-level analog voltage output (Figure 1). This voltage output is logic switch controlled, which allows these modules to share a common analog bus without the requirement of external multiplexers.

The SCM5B modules are designed with a completely isolated computer side circuit which can be floated to  $\pm 50V$  from Power Common, pin 16. This complete isolation means that no connection is required between I/O Common and Power Common for proper operation of the output switch. If desired, the output switch can be turned on continuously by simply connecting pin 22, the Read-Enable pin, to I/O Common, pin 19.

The SCM5B38 can interface to full-bridge or half-bridge transducers with a nominal resistance of  $100\Omega$  to  $10k\Omega$ . A matched pair of bridge-completion resistors (to  $\pm 1mV$  at  $+10V$  excitation) allows use of low cost half-bridge or quarter-bridge transducers (Figures 2, 3, 4).

Strain gage excitation is provided from the module by a very stable 10V or 3.333V source. The excitation supply is fully isolated, allowing the amplifier inputs to operate over the full range of the excitation voltage. This feature offers significant flexibility in real world applications. Full scale sensitivities of  $2mV/V$ ,  $3mV/V$  or  $10mV/V$  are offered as standard. With 10V excitation, this results in  $\pm 20mV$ ,  $\pm 30mV$  or  $\pm 100mV$  full scale input range producing  $\pm 5V$  full scale output.

After initial field side filtering the input signal is chopped by a proprietary chopper circuit. Isolation is provided by transformer coupling, again using a proprietary technique to suppress transmission of common mode spikes or surges. The module is powered from  $+5VDC$ ,  $\pm 5\%$ .

### ► Features

- Interfaces to  $100\Omega$  Thru  $10k\Omega$ , Full-Bridge, Half-Bridge, or Quarter-Bridge Strain Gages
- High-Level Voltage Output
- 1500Vrms Transformer Isolation
- ANSI/IEEE C37.90.1 Transient Protection
- Input Protected to 240VAC Continuous
- Fully Isolated Excitation Supply
- 160dB CMR
- 95dB NMR at 60Hz, 90dB at 50Hz
- 4Hz Signal Bandwidth
- $\pm 0.03\%$  Accuracy
- $\pm 0.01\%$  Linearity
- $\pm 1\mu V/^\circ C$  Drift
- CSA C/US Certified
- CE and ATEX Compliant
- Mix and Match SCM5B Types on Backpanel

Special input circuits on the SCM5B38 module provide protection of the signal inputs and the isolated excitation supply up to 240VAC.

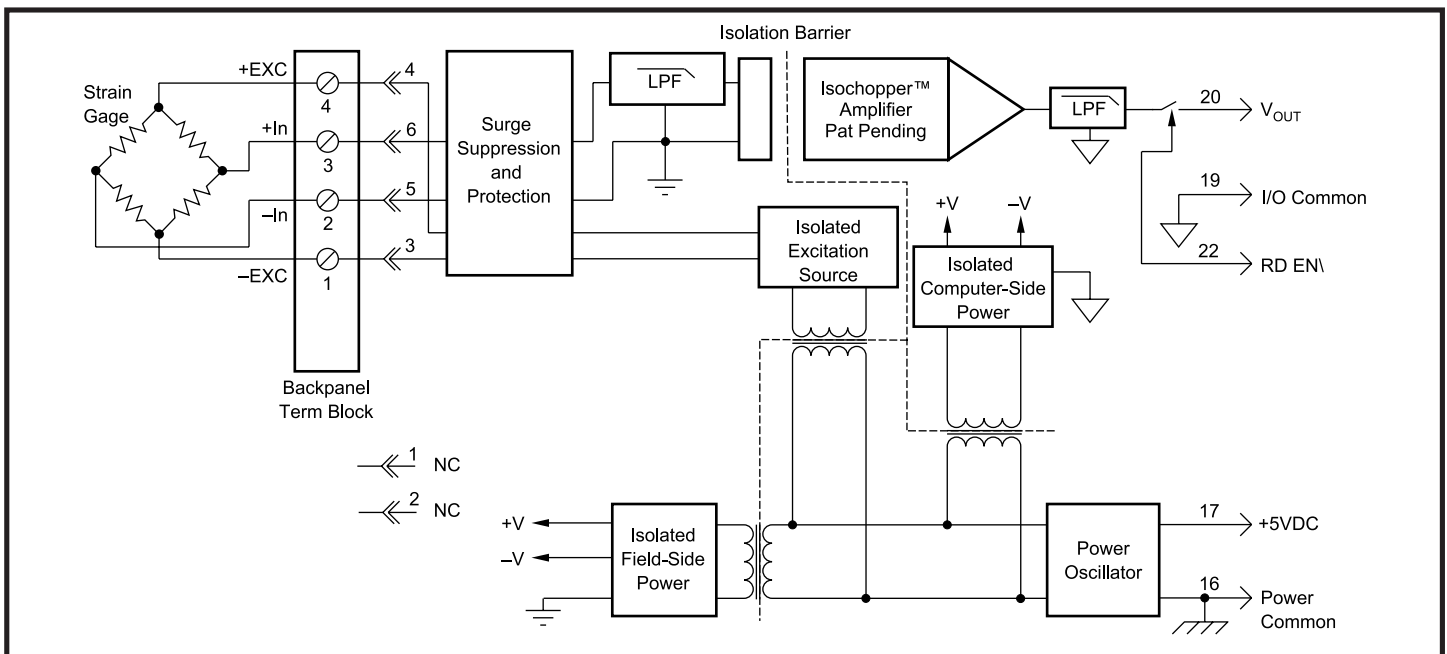

Figure 1: SCM5B38 Block Diagram

**Specifications** Typical\* at  $T_A = +25^\circ\text{C}$  and +5VDC power

Module	Full Bridge SCM5B38-31,-32,-35,-36,-37	Half Bridge SCM5B38-33,-34
Input Range	$\pm 10\text{mV}$ to $\pm 100\text{mV}$	*
Input Bias Current	$\pm 0.5\text{nA}$	*
Input Resistance		
Normal	50M $\Omega$	*
Power Off	40k $\Omega$	*
Overload	40k $\Omega$	*
Signal Input Protection		
Continuous	240Vrms max	*
Transient	ANSI/IEEE C37.90.1	*
Excitation Output (-32, -34, -35, -37)	+10V $\pm 3\text{mV}$	*
Load Resistance	300 $\Omega$ to 10k $\Omega$	*
Excitation Output (-31, -33, -36)	+3.333V $\pm 2\text{mV}$	*
Load Resistance	100 $\Omega$ to 10k $\Omega$	*
Excitation Load Regulation	$\pm 5\text{ppm/mA}$	*
Excitation Stability	$\pm 15\text{ppm}/^\circ\text{C}$	*
Half Bridge Voltage Level (-34)	NA	+5V $\pm 1\text{mV}$
Half Bridge Voltage Level (-33)	NA	+1.667V $\pm 1\text{mV}$
Isolated Excitation Protection		
Continuous	240Vrms max	*
Transient	ANSI/IEEE C37.90.1	*
CMV, Input to Output		
Continuous	1500Vrms max	*
Transient	ANSI/IEEE C37.90.1	*
CMR (50 or 60Hz)	160dB	*
NMR	95dB at 60Hz, 90dB at 50Hz	*
Accuracy <sup>(2)</sup>	$\pm 0.03\%$ Span	*
Linearity	$\pm 0.01\%$ Span	*
Stability		
Input Offset	$\pm 1\mu\text{V}/^\circ\text{C}$	*
Output Offset	$\pm 20\mu\text{V}/^\circ\text{C}$	*
Gain	$\pm 25\text{ppm}$ of Reading/ $^\circ\text{C}$	*
Noise		
Input, 0.1 to 10Hz	0.2 $\mu\text{Vrms}$	1 $\mu\text{Vrms}$
Output, 100kHz	200 $\mu\text{Vrms}$	*
Bandwidth, -3dB	4Hz	*
Response Time, 90% Span	0.2s	*
Output Range	See Ordering Information	*
Output Resistance	50 $\Omega$	*
Output Protection	Continuous Short to Ground	*
Output Selection Time (to $\pm 1\text{mV}$ of $V_{\text{OUT}}$ )	6 $\mu\text{s}$ at $C_{\text{load}} = 0$ to 2000pF	*
Output Current Limit	$\pm 8\text{mA}$	*
Output Enable Control		
Max Logic "0"	+0.8V	*
Min Logic "1"	+2.4V	*
Max Logic "1"	+36V	*
Input Current "0,1"	0.5 $\mu\text{A}$	*
Power Supply Voltage	+5VDC $\pm 5\%$	*
Power Supply Current	170mA Full Exc. Load, 70mA No Exc. Load	*
Power Supply Sensitivity	$\pm 2\mu\text{V}/\%$ RTI <sup>(3)</sup>	*
Mechanical Dimensions (h)(w)(d)	2.28" x 2.26" x 0.60" (58mm x 57mm x 15mm)	*
Environmental		
Operating Temperature Range	-40 $^\circ\text{C}$ to +85 $^\circ\text{C}$	*
Storage Temperature Range	-40 $^\circ\text{C}$ to +85 $^\circ\text{C}$	*
Relative Humidity	0 to 95% Noncondensing	*
Emissions EN61000-6-4	ISM, Group 1	*
Radiated, Conducted	Class A	*
Immunity EN61000-6-2	ISM, Group 1	*
RF	Performance A $\pm 0.5\%$ Span Error	*
ESD, EFT	Performance B	*

NOTES:  
 \* Contact factory or your local Dataforth sales office for maximum values.  
 \* Same as -31, -32, -35, -36, -37 modules.

(1) Strain element.  
 (2) Includes linearity, hysteresis and repeatability.  
 (3) RTI = Referenced to input.

**Ordering Information**

Model	Input Bridge Type	Input Range	Excitation	Sens.	Output Range <sup>†</sup>
SCM5B38-31	Full	-10mV to +10mV	+3.333V	3mV/V	1, 2
SCM5B38-32	Full	-30mV to +30mV	+10.0V	3mV/V	1, 2
SCM5B38-33	Half	-10mV to +10mV	+3.333V	3mV/V	1, 2
SCM5B38-34	Half	-30mV to +30mV	+10.0V	3mV/V	1, 2
SCM5B38-35	Full	-20mV to +20mV	+10.0V	2mV/V	1, 2
SCM5B38-36	Full	-33.3mV to +33.3mV	+3.333V	10mV/V	1, 2
SCM5B38-37	Full	-100mV to +100mV	+10.0V	10mV/V	1, 2

**†Output Ranges Available**

Output Range	Part No. Suffix	Example
1. -5V to +5V	NONE	SCM5B38-31
2. -10V to +10V	D	SCM5B38-31D

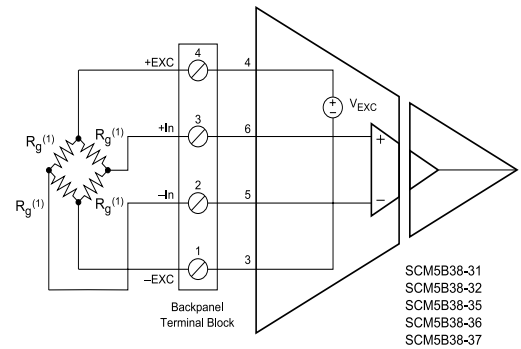

Figure 2: Full Bridge Connection

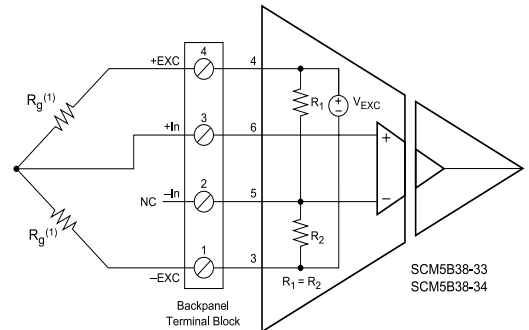

Figure 3: Half Bridge Connection

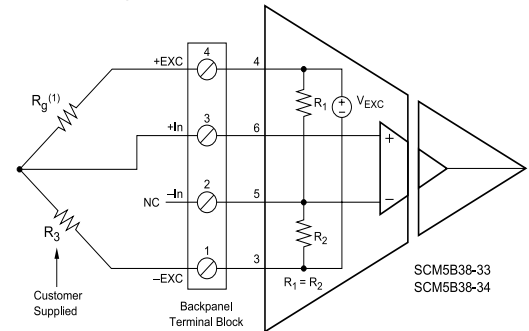

Figure 4: Quarter Bridge Connection