

The accessories

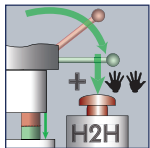
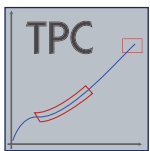
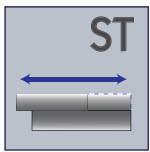
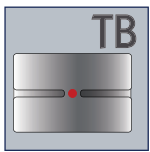
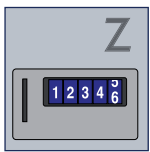
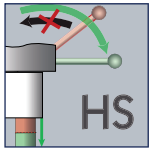
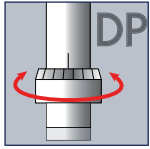

Für
EP 500-40
EP 750-40
VK 500-40
VK 750-40

Manual toggle presses with round ram EP range

EP Type toggle presses in 5 kN, 7.5 kN and 12 kN sizes are designed for serial or individual manufacture in manual workstations.

As the nominal end force is produced at the end of the stroke, a large force can be exerted at the exact point it is required. The manual force of 120 N to be applied is user-friendly. As many applications require less force, fatigue-free working is possible even with serial production.

ERGOPRESS® hand lever

- ▶ Ergonomic user comfort.
- ▶ 360° stepless adjustment
- ▶ Lever angled to the side: free view of work area and ergonomically comfortable position.
- ▶ Simple and easy conversion for left-handers (except HS and Z option) without losing the tool setting. Ideal for job sharing on one press.

EP-type presses are modern production tools with high precision. The user-friendly design increases productivity and prevents forced and abnormal postures of the operator due to the workplace.



Manual lever can be refitted for right and left-handers

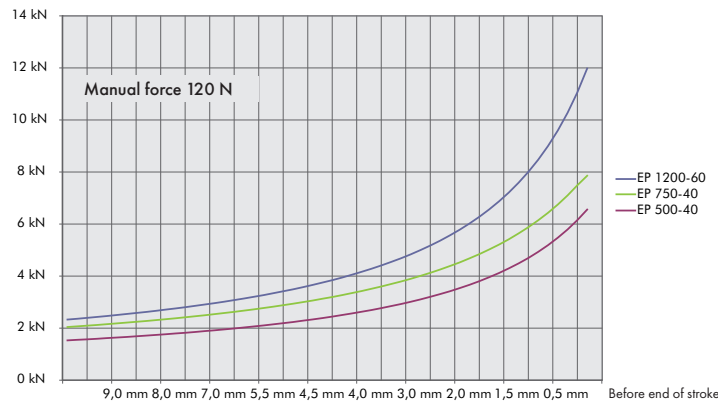

Standard

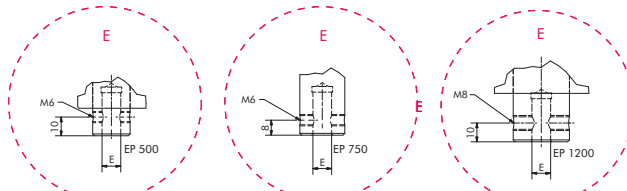

With DP

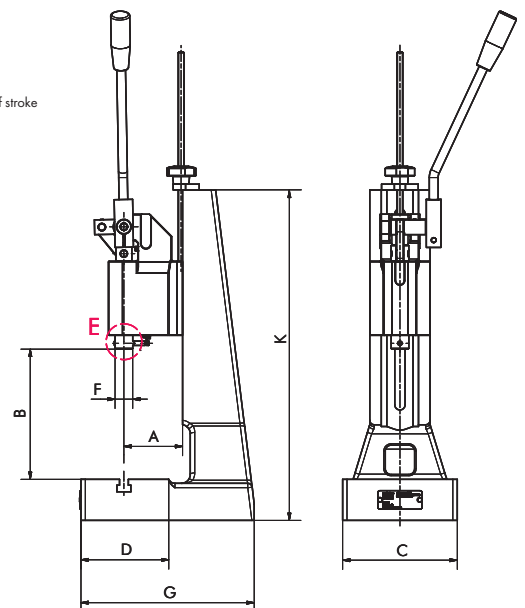
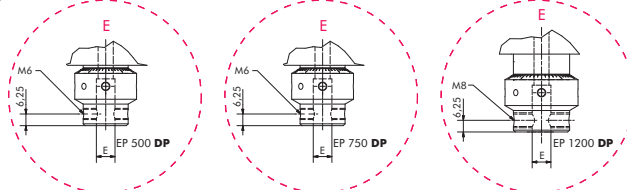

EP range
L-EP range with extra large daylight

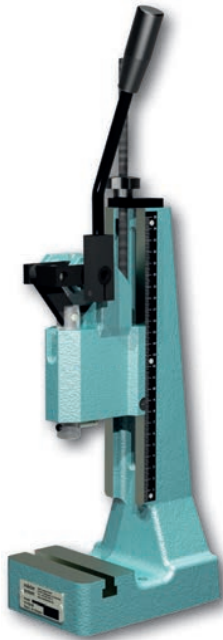

EP 500-40

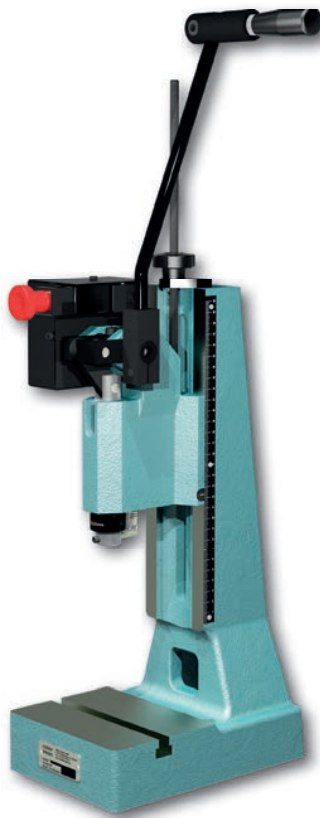

EP 750-40

with accessories
DP - Precision ram adjustment
HS - Return travel lock
equipped with ERGO hand lever*

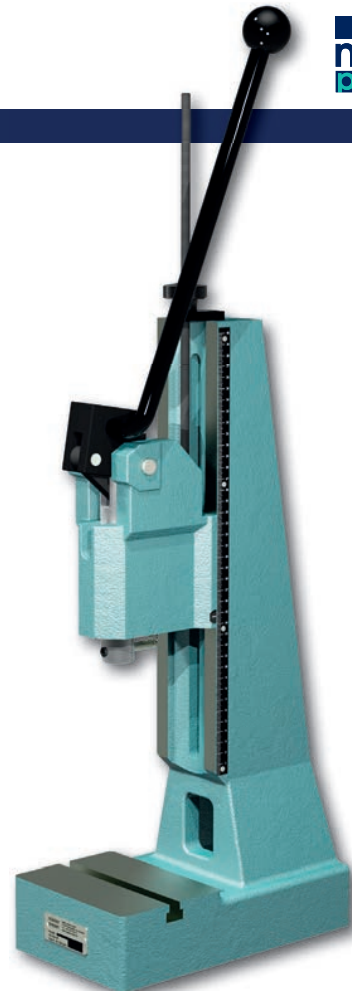

L-EP 1200-60

Toggle presses

Type			EP 500-40	EP 750-40	L-EP 750-40	EP 1200-60	L-EP 1200-60
Capacity		kN	5.0	7.5	7.5	12.0	12.0
Working stroke		mm	40	40	40	60	60
Throat	A	mm	63	80	80	80	80
Daylight	B	mm	40 - 213	58 - 265	55 - 375	62 - 240	75 - 338
Daylight with DP	B	mm	20 - 197	38 - 250	39 - 359	48 - 231	53 - 328
Table size	CxD	mm	110 x 65	157 x 115	156 x 115	157 x 115	157 x 115
T-slot width similar to DIN 650		mm	10	12	12	12	12
Ram bore Ø x Depth	E	mm	10H7 x 25	10H7 x 25	10H7 x 25	10H7 x 30	10H7 x 30
Ram bore Ø x Depth with DP	E	mm	10H7 x 25	10H7 x 25	10H7 x 25	10H7 x 25	10H7 x 25
Ram Ø	F	mm	20	24	24	30	30
Space requirement	CxG	mm	110 x 164	157 x 237	156 x 275	157 x 237	156 x 275
Stand height	K	mm	355	450	570	450	570
Weight		kg	ca. 10	ca. 20	ca. 28	ca. 24	ca. 32

Accessories (see Page 8-9)	Please specify when ordering.				
Precision ram adjustment	DP	DP	DP	DP	DP
Return travel lock	HS	HS	HS	HS	HS
Counter	Z	Z	Z	Z	Z
Table bore 12H7	TB	TB	TB	TB	TB

*Not included. Accessories must be ordered separately.