

MOUNTING PORT PREPARATION: 3035B
 SELECT OR PREPARE A FLAT AREA OF AT LEAST Ø.250, FLAT TO .001 TIR.
 AT THE CENTER, DRILL #38 (Ø.101) X .150 DEEP, MIN.
 TAP 5-40 UNC-2B X .125 DEEP, MIN.

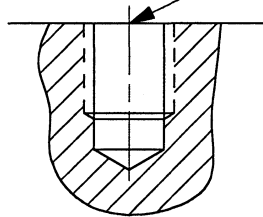

MODEL 3035B

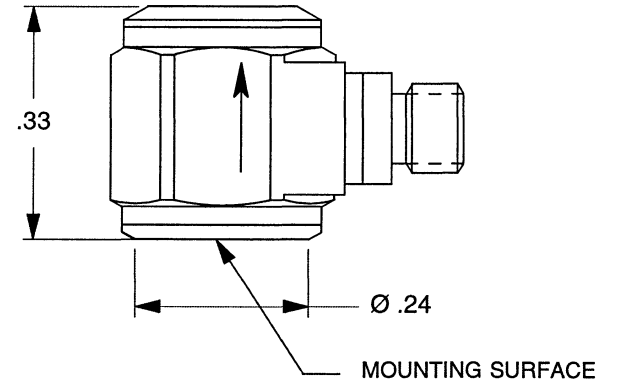

MODEL 3035BG

MOUNTING SURFACE PREPARATION: 3035BG
 SELECT OR PREPARE A FLAT AREA OF AT LEAST Ø.250, FLAT TO .001 TIR. CLEAN TO REMOVE CONTAMINANTS. APPLY ADHESIVE TO SURFACE OR TO ACCELEROMETER AND PRESS TOGETHER UNTIL ADHESIVE SETS.

- 2. MOUNTING TORQUE ON .281 HEX: 3 TO 4 LB.-IN.
- 1. WEIGHT: 2.5 GRAMS.

DIYTRAN INSTRUMENTS, INC.		MASTER ONLY IF IN RED		CHATSWORTH, CA.	
SCALE	4X	REV	D	DATE	6/10/04
DATE	12/02/02	ECN	N/A	PART NO.	MODELS 3035B, 3035BG
DRAWN	N.C.	CHECKED	R.A.	MATL	
APPROVED	[Signature]		NEXT ASSEMBLY	USED ON	
TITLE				DWG NO.	
OUTLINE/INSTALLATION DRAWING, MODELS 3035B & 3035BG LIVM ACCELEROMETERS				127-3035B/G	
				SHEET 1 OF 1	

Model Number 3035BG	PERFORMANCE SPECIFICATIONS	DOC NO PS3035BG
	IEPE ACCELEROMETER	REV A, ECN 11126, 07/7/14



- MINATURE SIZE
- HERMETICALLY SEALED
- ADHESIVE MOUNT

PHYSICAL

Weight, Max.
Connector
Mounting Provision
Material, Housing/Connector
Sensing Element
Element Style

ENGLISH		SI	
0.09	oz	2.5	grams
5-44 Coaxial		5-44 Coaxial	
Adhesive		Adhesive	
300 Series Stainless Steel		300 Series Stainless Steel	
Ceramic		Ceramic	
Shear		Shear	

PERFORMANCE

Sensitivity, ±10% [1]
Range for ± 5 Volts Output
Frequency Response, ±10%
Resonant Frequency
Broad Band Resolution
Linearity [2]
Maximum Transverse sensitivity
Strain Sensitivity @ 250µε

100	mV/g	10.2	mV/m/s ²
±50	g	±490.5	m/s ²
0.5 to 10000	Hz	0.5 to 10000	Hz
> 45	kHz	> 45	kHz
0.007	Grms	0.069	m/s ² rms
±1	% F.S.	±1	% F.S.
5	%	5	%
0.002	g/µε	0.02	m/s ² /µε

ENVIRONMENTAL

Maximum Vibration
Maximum Shock
Temperature Range
Seal

600	Gpeak	5884	m/s ² peak
10000	Gpeak	98067	m/s ² peak
-60 to +250	°F	-51 to +121	°C
Hermetic		Hermetic	

ELECTRICAL

Supply Current Range [3]
Compliance Voltage Range
Output Impedance, Typ
Bias Voltage
Discharge Time Constant
Electrical Isolation

2 to 20	mA	2 to 20	mA
18 to 30	Volts	18 to 30	Volts
100	Ω	100	Ω
11 to 13	VDC	11 to 13	VDC
1 to 2	Sec	1 to 2	Sec
Case Grounded	GΩ,min	Case Grounded	GΩ,min

This family also includes:

Model	Range F.S. (g)	Sensitivity (mV/g)	Time Constant (Sec)
3035B1G	± 500	10	1 to 2
3035B2G	± 100	50	1 to 2
3035B3G	± 1000	5	1 to 2

Refer to the performance specifications of the products in this family for detailed description

Supplied Accessories:

- 1) Accredited calibration certificate (ISO 17025)

Notes:

- [1] Measured at 100Hz, 1 Grms per ISA RP 37.2.
- [2] Measure using zero-based straight line method, % of F.S. or any lesser range.
- [3] Do not apply power to this system without current limiting, 20 mA MAX. To do so will destroy the IC charge amplifier.
- [4] In the interest of constant product improvement, we reserve the right to change specifications without notice.

TYPICAL LOW FREQUENCY RESPONSE

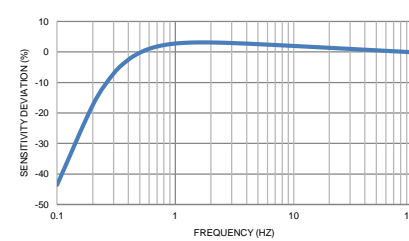

TYPICAL TEMPERATURE RESPONSE

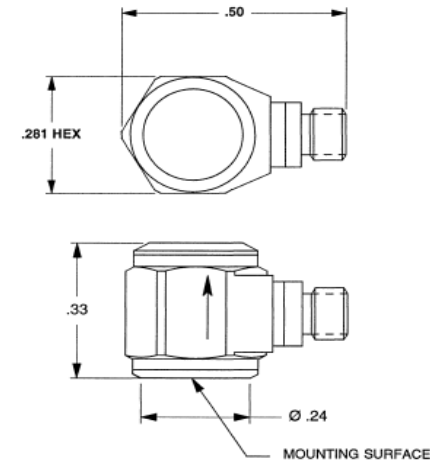
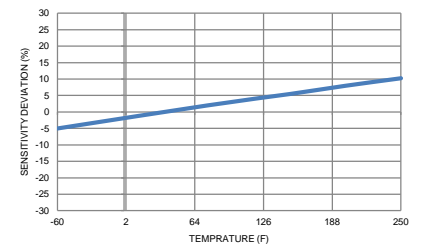

Units on the line drawing are in inches, units in brackets are in millimeters. Refer to 127-3035B/G for more information.



21592 Marilla Street, Chatsworth, California 91311 Phone: 818.700.7818 Fax: 818.700.7880 www.dytran.com
For permission to reprint this content, please contact info@dytran.com



Presented by: Absolute Gauge Technologies
sales@absolute-gauge.com; www.absolute-gauge.com,
Toronto: 416 754 3168, Montreal: 514 695 5147, Toll Free: 1 888 754 7008