

MR-F5-1600-HI(CE)

Forklift Mobile Robot



Key Feature

- Carrying goods via fork. Supports gantry customization and fork size customization.
- Adopts SLAM navigation to achieve accurate positioning.
- Supports smooth motions with max. running speed of 1.5 m/s.
- Adopts smart/independent power management, and supports auto-charge and self-returning after charging completed, and environmental friendly.
- Adopts multiple safety protections like laser/infrared obstacle avoidance, load detection, emergency stop button, audible alarm, etc.
- Supports lifting, carrying, rotating and lowering goods up to 1600 kg (3527.40 lb.) via standard pallets.
- Supports indicating device status via LCD screen and status indicator.
- Supports Wi-Fi communication and seamless roaming and operation smoothly in a network-covered area.

Typical Application

E-commerce, electronics manufacturing, automobile, consumer electronics, mechanical manufacturing, texture, tobacco, medicine, etc.

Available Model

MR-F5-1600-HI(CE)

Accessory

Charging station: CH-48/60(CE)



Dimension

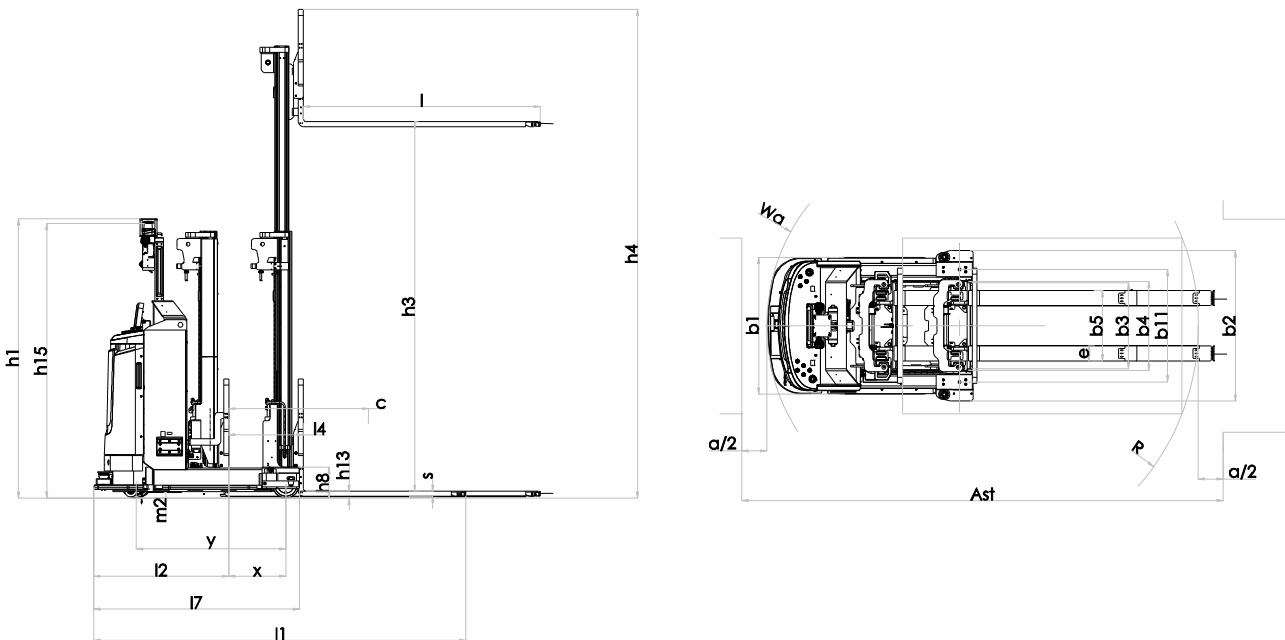

Loading Curve

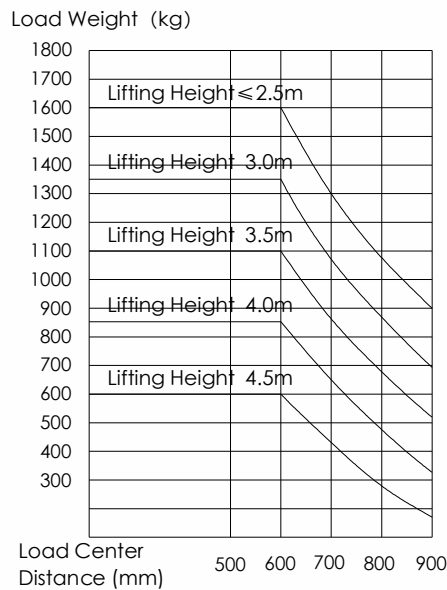

Charging Station Deployment

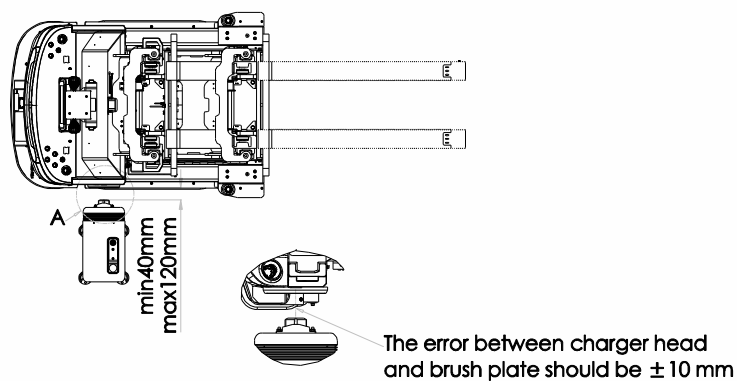

Specification

Model	MR-F5-1600-HI(CE)
Basic Parameter	
Dimension	2324 mm × 1200 mm × 2219 mm (91.50" × 47.24" × 87.36")
Weight (with Battery)	2310 kg (5092.68 lb.)
Rated Load	1600 kg (3527.40 lb.)
Load Center Distance	1125 mm (44.29")
Wheelbase	1205 mm (47.44")
Lifting Height	3000 mm (118.11")
Max. Gantry Height	3895 mm (153.35")
Fork above Ground after Lowering	54 mm (2.13")
Fork Height/Width/Length	43 mm/123 mm/1907 mm (1.69"/4.84"/75.08")
Fork Distance	560 mm (22.05")
Min. Ground Clearance	43 mm (1.69")
Applicable Pallet Dimension	2250 mm × 1400 mm (88.58" × 55.12")
Laser Scan Height	2187 mm (86.10")
Min. Rotation Radius	1550 mm (61.02")
Right Angled Passage Width	3874 mm (152.52")
Motion Performance	
Running Speed (Full Load/Empty)	1.2/1.5 m/s
Positioning Accuracy	± 10 mm (0.39")
Positioning Angle Accuracy	± 1°
Repeated Positioning Accuracy	± 10 mm (0.39")
Max. Gradeability (Full Load/Empty)	5/8%
Lifting Fork Speed (Full Load/Empty)	120/150mm/s
Lowering Fork Speed (Full Load/Empty)	140/140mm/s
Motion Method	Steering wheel driving. Supports forward, backward, arc motion and rotation on site.
Battery Performance	
Rated Voltage	48 V
Capacity	125 Ah
Charge Cycle	1500 times (for fully charging and discharging)
Endurance	6 h to 8 h
Charge Time	≤ 3 h (for fully charging and discharging)
Charge Method	Side
Safety Protection	
Laser Obstacle Avoidance	Supports
Driving Recorder	Optional
Bumper Strip	Supports
Pallet Detection	Supports
Fork Collision Detection	Supports
Emergency Stop Button	Supports
Audible and Visual Alarm	Supports
Others	
Drive Method	Front wheel driving and steering by motor
Screen	Supports
Navigation Mode	Laser SLAM (reflector panel)
Manual Operation	Manual controller (optional), HikRobot mobile terminal application
Noise	≤ 75 dB