

W(G)S3 Position Sensor with Analog or A/D converted synchronous serial output

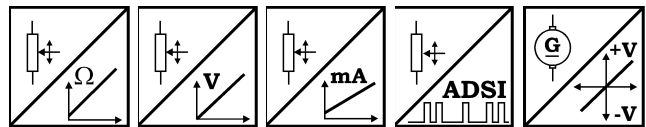

Position and Velocity Sensor for Medium Ranges

- Protection Class IP50
- Measurement Range:
0 ... 3750 mm to 0 ... 7500 mm
0 ... 147.6 in to 0 ... 295.3 in
- With Analog Output or
A/D converted synchronous serial output



Specifications	Outputs	Potentiometer: 1 kΩ Voltage: 0...10 V Current: 4...20 mA, 2 or 3 wire Voltage and Current output, adjustable A/D converted synchronous serial 12 Bit RS-485 Scaled / unscaled DC Tachometer
	Resolution	Essentially infinite / ADSI: 12 Bit Full Scale
	Material	Aluminium and Stainless Steel. Cable: Stainless Steel. Housing: Anticorrosive Sheet Steel
	Sensing Device	Precision Potentiometer
	Connector	Male Socket 8 pin DIN 45326
	Position Linearity	Up to ±0.05 % Full Scale
	Velocity Linearity	Up to ±0.25 % Full Scale

Order Code

WS3 / GS3 / WGS3

XXX3 - [] - [] - [] - [] - D8

Model Name

WS = Position Sensor
GS = Velocity Sensor
WGS = Position and Velocity Sensor

Measurement Range (in mm)

3750 / 5000 / 7500

Position Outputs

R1K = Potentiometer 1 kΩ (other Values on Request, e.g. 500 Ω)
10V = with 0 ... 10 V Signal Conditioner
420A = with 4 ... 20 mA Signal Conditioner (2 wire)
420T = with 4 ... 20 mA Signal Conditioner (3 wire)
PMU = with 0...10 V/4...20 mA Signal Conditioner, adjustable
ADSI = with A/D converted synchronous serial output 12 Bit / RS-485

Velocity Outputs

TA = approx. 10 V/m/s; 0.423 V/100in/min (unscaled DC Tachometer Output)
T5 = 5 V/m/s; 0.212 V/100in/min (scaled DC Tachometer Output)
Scaled Signal Conditioner:
V2 = ±2 mm/s = ±10 VDC V10 = ±10 mm/s = ±10 VDC V25 = ±25 mm/s = ±10 VDC
V50 = ±50 mm/s = ±10 VDC V100 = ±100 mm/s = ±10 VDC V250 = ±250 mm/s = ±10 VDC

Linearity (Position)

L10 = ±0.10 % (L05 on request)
L25 = ±0.25 %

DIN connector

D8 = Connector 8 pin DIN 45326

Order Code Mating Connector (see accessories page 105)

WS-CONN-D8

Order Example: WS3 - 5000 - 10V - L10 - D8

W(G)S3 Position Sensor with Analog or A/D converted synchronous serial output



Specifications (Continuation)	Protection Class (IEC 529)	IP50
	Weight	3.1 kg approx.
	Environmental	
	Immunity to Interference (EMC)	Refer to Output Specification
	Temperature	Refer to Output Specification

Cable Forces typical at 20 °C	Range		Maximum Pull-out Force	Minimum Pull-in Force
	[mm]	[in]	[N]	[N]
	3750	147.6	10.1	4.7
	5000	196.9	7.1	3.5
	7500	295.3	5.3	2.5

Outline drawing

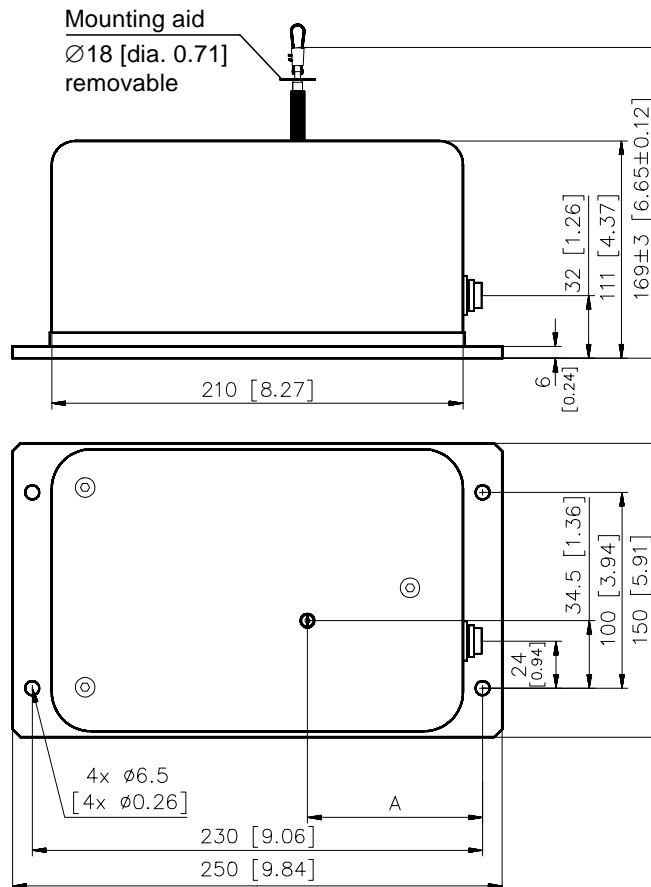

Dimensions in brackets are inches.
For guaranteed dimensions consult factory

Dimensions	Model	A
	WS3	122 [4.8 in]
	GS3; WGS3	89.5 [3.52 in]

WS Position Sensors

Output Specifications R1K and 10V



Voltage divider R1K Potentiometer 	Excitation Voltage	32 VDC max. at 1 kΩ (Input Power 1 W max.)
	Potentiometer Impedance	1 kΩ ±10%
	Thermal coefficient	±0.0025% / K Full Scale
	Sensitivity	Depends on measurement range, individual sensitivity of sensor specified on label
	Voltage Divider Utilization Range	Approx. 3% ... 97% of Full Range
	Operating Temperature	-20 ... +85 °C

Signal diagram

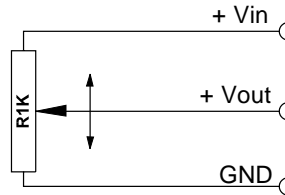

Note: The potentiometer must be connected as a voltage divider. The input impedance of the following processing circuit should be 10 MΩ min.

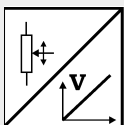
Signal conditioner 10V Voltage output 	Excitation Voltage	+18 ... +27 V DC non stabilized
	Excitation Current	20 mA max.
	Output Voltage	0 ... +10 V DC
	Output Current	2 mA max.
	Output Load	> 5 kΩ
	Stability (Temperature)	±0.005% / K Full Scale
	Protection	Reverse Polarity, Permanent Short Circuit
	Output Noise	0,5 mVRMS
	Operating Temperature	-20 ... +85 °C
	Immunity to interference (EMC)	According to EN 61326: 1998

Signal diagram

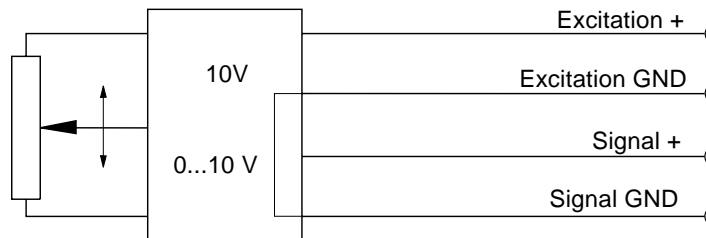

Signal Wiring	Output Signals	Connector	WS-CONN-D8
	R1K	10V	
	+ Vin	Excitation +	1
	GND	Excitation GND	2
	+ Vout	Signal +	3
		Signal GND	4
			5
			6
			7
			8

Connection

Mating Connector

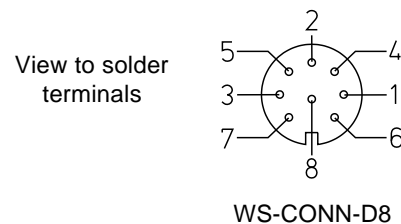

WS Position Sensors

Output Specifications 420A and 420T

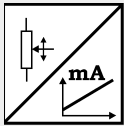

Signal conditioner 420A Current output (2 wire) 	Excitation Voltage	+12 ... 27 VDC non stabilized, measured at the sensor terminals
	Excitation Current	35 mA max.
	Output Current	4 ... 20 mA equivalent to 0 ... 100% Range
	Stability(Temperature)	±0.01% / K Full Scale
	Protection	Reverse Polarity, Permanent Short Circuit
	Output Noise	0.5 mV _{RMS}
	Operating Temperature	-20 ... +85 °C
	Immunity to Interference (EMC)	According to EN 61326: 1998

Signal Diagram

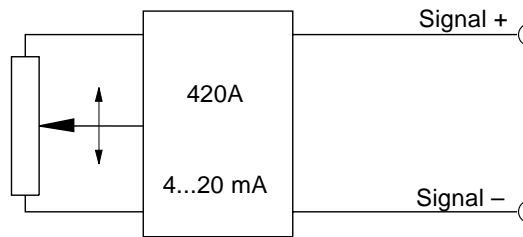

Signal Conditioner 420T Current output (3 wire) 	Excitation Voltage	+18...+27 V DC non stabilized
	Excitation Current	40 mA max.
	Load Resistor	350 Ω max.
	Output Current	4 ... 20 mA equivalent to 0 ... 100% Range
	Stability (Temperature)	±0.005% / K Full Scale
	Protection	Reverse Polarity, Permanent Short Circuit
	Output Noise	0.5 mV _{RMS}
	Operating Temperature	-20 ... +85 °C
Immunity to Interference	According to EN 61326: 1998	

Signal diagram

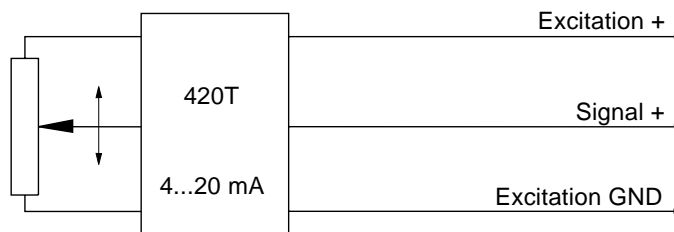

Signal Wiring	Output Signals		Connector	WS-CONN-D8
	420A	420T		
	Signal +	Excitation +		1
	Signal -	Excitation GND		2
		Signal +		3
				4
				5
				6
				7
				8

Connection

Mating Connector

View to solder terminals

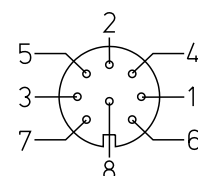

WS-CONN-D8

WS Position Sensors

Output Specification PMU

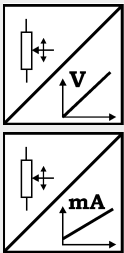

Signal Conditioner PMU, adjustable Voltage output and current output (3 wire) 	Excitation voltage	+18 ... 27 V DC
	Excitation current	50 mA max.
	Voltage output	0 ... 10 V
	Output current	10 mA max.
	Output load	1 kΩ min.
	Current output	4 ... 20 mA (3 wire)
	Load resistor	500 Ω max.
	Adjustment	
	Activation of offset and gain adjust	Connect with excitation GND (0 V)
	Scalable range	90 % max. full scale
	Stability (Temperature)	±50 ppm/°C full scale
	Protection	Reverse polarity, short circuit
	Output noise	1 mV _{eff}
	Operating temperature	-20 ... +85 °C
EMC		
Immunity to interference	EN 61000-4-2, -4, -5, -6	
Influence according to EN 61000-4-6	1 % max. at testing strength 4	
Emmission of interference	CISPR 11	

Signal diagram

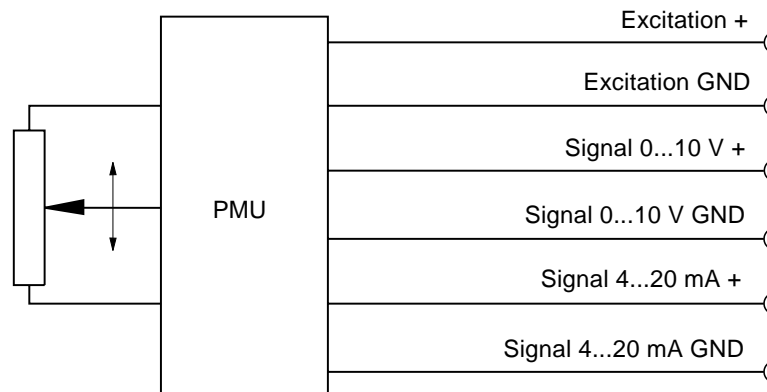

Signal wiring	Output signals PMU	Connector WS-CONN-D8
	Excitation +	1
	Excitation GND	2
	Signal 0...10 V +	3
	Signal 0...10 V GND	4
	Signal 4...20 mA +	5
	Signal 4...20 mA GND	6
	Offset	7
	Gain	8

Connection

Mating Connector

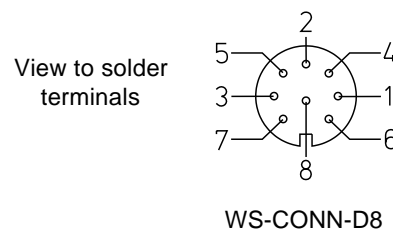

WS Position Sensors

Output Specification ADCAN



Description

Signal conditioner with CANopen interface for WS Position Sensors and AWS Angle Sensors. The sensing device of the ADCAN is a precision potentiometer. Start, stop, synchronization of the position data transmission and parameter programming will be supported according to the CANopen standard DS301. Two process data objects (PDO) will be transmitted to transfer the position value and cam events.

Signal Conditioner ADCAN (CANopen)

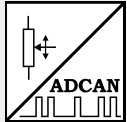

CANopen interface	
Excitation Voltage	+24 V
Specifications	Communication Profile DS301 Encoder Profile DS406
One Service Data Object (SDO)	Parameter setting
Two Process Data Objects (PDO)	Position value, cam
Transmission Rate	125 kBd, variable by SDO
Node ID	Default 01, variable by SDO
Resolution	16 Bit
Transmission mode	Synchronous, asynchronous cyclic or dependant on event

Output signals

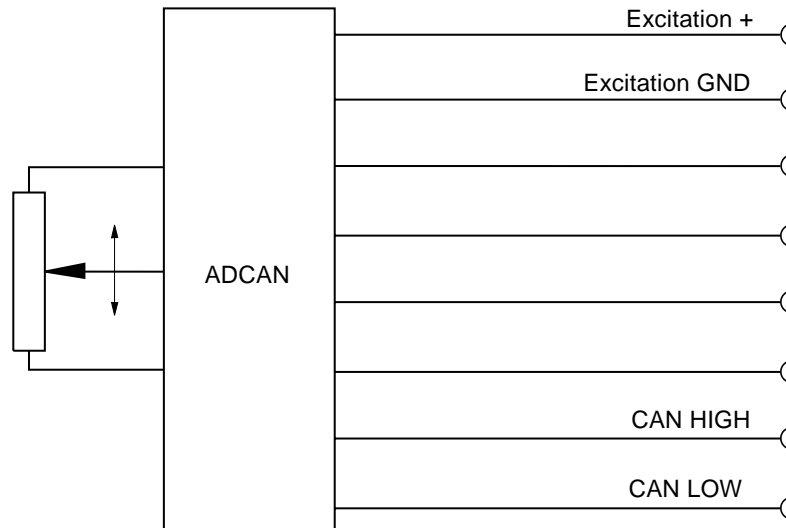

Signal wiring

Signals ADCAN	Connector WS-CONN-D8
Excitation +24 V	1
Excitation GND	2
CAN LOW	7
CAN HIGH	8

Connection

Mating connector

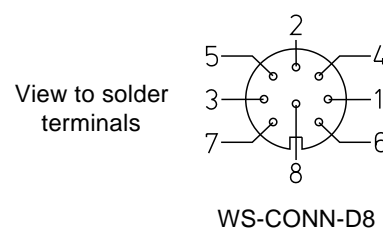

WS Position Sensors

Output Specifications TA and T5

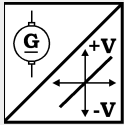

Tacho TA Unscaled DC Tachometer 	Output Voltage	100 VDC maximum permissible (self-generating)
	Output Load	> 100 kΩ
	Stability (Temperature)	±0.02% / K Full Scale
	Output Impedance	500 Ω approx.
	Sensitivity	10 V/m/s approx., depends on the tachometer design: Individual measured sensitivity specified on label.
	Linearity	±1%
	Operation Temperature	-20 ... +85 °C
	Immunity to Interference (EMC)	According to EN 61326: 1998

Signal Diagram

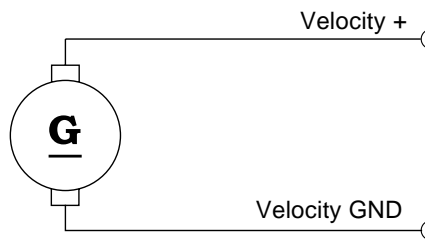

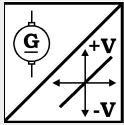
Tacho T5 Scaled DC Tachometer 	Output voltage	50 VDC maximum permissible (self-generating)
	Output Load	> 100 kΩ
	Stability (Temperature)	±0.02% / K Full Scale
	Output Impedance	500 Ω approx.
	Sensitivity	5 V/m/s
	Linearity	±1%
	Operation Temperature	-20 ... +85 °C
	Immunity to Interference (EMC)	According to EN 61326: 1998

Signal Diagram

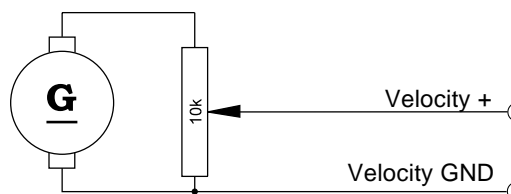

Signal Wiring	Output Signals	Connector
	TA	T5
		1
		2
		3
		4
	Velocity +	5
	Velocity GND	6
		7
		8

Connection

Mating Connector

View to solder terminals

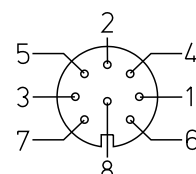

WS-CONN-D8

WS Position Sensor Output Specification VXXX

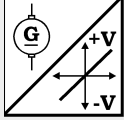

Signal Conditioner VXXX Scaled DC Tachometer 	Excitation Voltage	+14 ... +27 VDC non stabilized
	Excitation Current	20 mA max.
	Output Voltage	-10 ... +10 VDC
	Output Current	1 mA max.
	Output Load	> 10 kΩ
	Stability (Temperature)	±0.01% / K Full Scale
	Protection	Reverse Polarity, Permanent Short Circuit
	Output Noise	0.5 mV _{RMS}
	Velocity Ranges	2 / 10 / 25 / 50 / 100 / 250 mm/s
	Linearity	±0.25% Full Scale, <100 mm/s: 1 % Full Scale
	Operating Temperature	-20 ... +85 °C
Immunity to interference (EMC)	According to EN 61326: 1998	

Signal Diagram

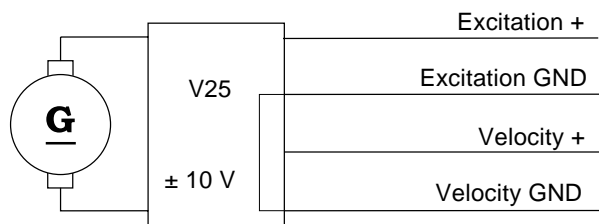

Signal Wiring	Output Signals VXXX	Connector WS-CONN-D8
	Excitation +	1
	Excitation GND	2
		3
		4
	Velocity +	5
	Velocity GND	6
		7
		8

Connection Mating Connector

View to solder terminals

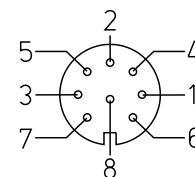

WS-CONN-D8

WS Position Sensors

Output Specification ADSI



- Resolution 12 Bit, Data Transmission synchronous serial
- No Loss of Data at Power-down
- Easy to Connect to PLC's with SSI Input Circuit

Description

The sensing device of the ADSI is a precision potentiometer. The position information is given by an analog/digital converter output serialized as a data word. Data transmission takes place by means of the signals CLOCK and DATA. The processing unit (PLC, Micro-computer) sends pulse sequences which clock the data transmission with the required transfer rate. With the first falling edge of a pulse sequence the position of the sensor is recorded and stored. The following rising edges control the bit-by-bit A/D conversion, encoding and output of the data word.

After a delay time the next new position information will be transmitted.

Data Format (Train of 26 Pulses)

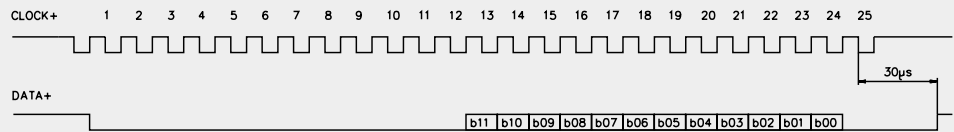

Signal Conditioner ADSI

A/D converted
synchronous serial

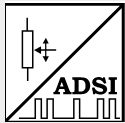

Output	EIA RS-422, RS-485, short-circuit proof
Excitation Voltage	11 ... 27 VDC
Excitation Current	200 mA max.
Clock Frequency	70 ... 500 kHz
Code	Gray Code, Continuous Progression
Delay between Pulse Trains	T=30 µs min.
Resolution	12 Bit (4096 Counts) Full Scale
Stability (Temperature)	±0.005% / K Full Scale
Operation Temperature	-20 ... +85 °C
Immunity to Interference (EMC)	According to EN 61326: 1998

Recommended Processing Input Circuit

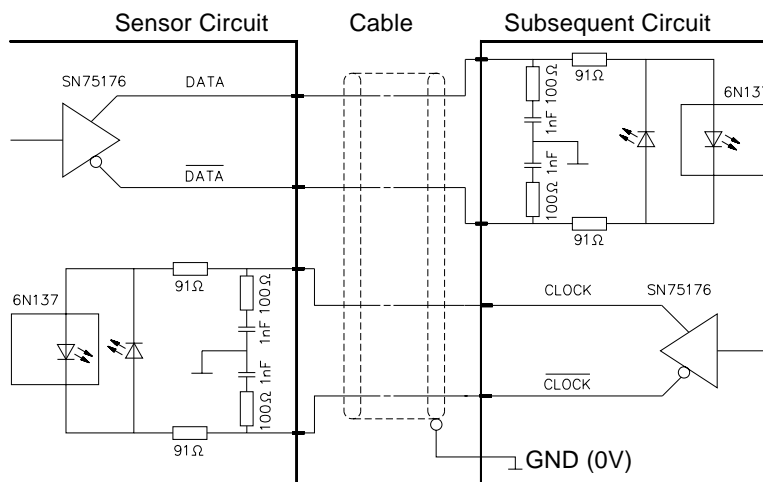

Cable Length	Baud Rate
50 m	300 kHz
200 m	100 kHz

Note:

Extension of the cable length will reduce the maximum transmission rate. The signals CLOCK/CLOCK and DATA/DATA must be connected in a twisted pair cable, shielded per pair and common.

Signal Wiring / Connection

Signal name	Connector Pin
Excitation +	1
Excitation GND (0V)	2
CLOCK	3
CLOCK	4
DATA	5
DATA	6
Screen	not connected

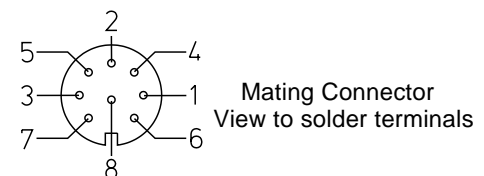

WS-CONN-D8