



Features

- 4-20 mA, 0-20 mA, 0-10V or -10V to +10V transmitter output, 16 bits, isolated
- RS232 or RS485 serial data output, Modbus or Laurel ASCII protocol, isolated
- Dual 120 mA solid state relays for alarm or control, isolated
- Two independently field-scalable pulse input channels A and B
- Arithmetic functions A+B, A-B, AxB, A/B, A/B-1 (draw) applicable to rate or total
- Frequencies from 0.005 Hz to 1 MHz
- Inputs from NPN or PNP proximity switches, contact closures, digital logic, magnetic pickups down to 12 mV, or AC inputs up to 250 Vac
- Analog output resolution 0.0015% of span (16 bits), accuracy $\pm 0.02\%$ of span
- 5V, 10V or 24V dc transducer excitation output, isolated
- Universal 85-264 Vac / 90-300 Vdc or 10-48 Vdc / 12-32 Vac power



Description

The Laureate dual pulse input transmitter accepts two independently scalable input channels A & B from a wide range of pulse sources, such as NPN or PNP proximity switches, contact closures, digital logic, magnetic pickups down to 12 mV, or AC voltages to 250 Vac. Input frequencies can range from 0.005 Hz to 1 MHz.

Arithmetic functions A+B, A-B, AxB, A/B or A/B-1 are made available by the Extended counter main board and can track the sum, difference, product, ratio, or draw of both input channels. These functions can be applied to scaled rates, scaled totals, square root of rates, totals after square root extraction, custom curve linearized rates, or totals after custom curve linearization.

- **Sum A+B** can be used to add two flows for total flow, or to add the number of parts carried by two conveyor belts.
- **Difference A-B** can be used to subtract outflow from inflow for net flow, or to subtract reject parts from total parts.
- **Product AxB** can be used to multiply two rates, for example to compute horsepower by multiplying torque by RPM.
- **Ratio A/B** can be used to compare flow rates in two channels, the RPM of rollers or gears, or the speed of moving machinery such as conveyor belts. Ratio can also be applied to scaled totals to compare two batches to be mixed. In this application, one transmitter is used to monitor the ratio of flow rates, and a second transmitter to monitor the resulting batch totals.
- **Draw A/B-1** is obtained by subtracting 1 from ratio. Draw is used to measure the elongation of material as it passes between rollers, or to monitor variation in the speed of rollers for tensioning.

Exceptional Accuracy and Stability. Laureate pulse input frequency and rate transmitters determine frequency by taking the inverse of the period as measured with a calibrated quartz crystal time base. Extremely accurate 6-digit internal readings ($\pm 999,999$ counts) are processed in software.

The update rate of the transmitter output is a programmed gate time + 30 ms + 0-2 signal periods. For pulse rates of 60 Hz and above, the update rate would be 20 per second. Such fast update rates are ideal for alarm and control.

Standard features of Laureate transmitters include:

- **4-20 mA, 0-20 mA, 0-10V or -10V to +10V analog output**, isolated, jumper-selectable and user scalable. All selections provide 16-bit (0.0015%) resolution of output span and 0.02% output accuracy of a reading from -99,999 to +99,999 counts that is also transmitted digitally. Output isolation from signal and power grounds eliminates potential ground loops.
- **Serial communications output**, isolated. User selectable RS232 or RS485, half or full duplex. Three protocols are user selectable: Modbus RTU, Modbus ASCII, or Laurel ASCII. Modbus operation is fully compliant with Modbus Over Serial Line Specification V1.0 (2002). The Laurel ASCII protocol allows up to 31 Laureate devices to be addressed on the same RS485 data line. It is simpler than the Modbus protocol and is recommended when all devices are Laureates.
- **Dual solid state relays**, isolated. Available for local alarm or control. Rated 120 mA at 130 Vac or 170 Vdc.
- **Transducer excitation output**, isolated. User selectable 5V@100 mA, 10V@120 mA or 24V@50 mA.
- **Universal 85-264 Vac power.** Low-voltage 10-48 Vdc or 12-32 Vac power is optional.

Easy Transmitter programming is via Laurel's Instrument Setup Software, which runs on a PC under MS Windows. This software can be downloaded from this website at no charge. The required transmitter-to-PC interface cable is available from Laurel (P/N CBL04).



Specifications

Pulse Input	
Signal Types	AC, pulses from NPN, PNP transistors, contact closures, magnetic pickups.
Grounding	Common ground for channels A & B
Channel A Frequency	0.005 Hz to 1 MHz
Channel B Frequency	0.005 Hz to 250 kHz
Minimum Signal	Nine ranges from (-12 to +12 mV) to (+1.25 to +2.1V)
Maximum Signal	250 Vac
Noise Filter	1 MHz, 30 kHz, 250 Hz (selectable)
Contact Debounce	0, 3, 50 ms (selectable)
Time Base Accuracy	Quartz crystal calibrated to ± 2 ppm
Arithmetic Functions	A+B, A-B, AxB, A/B, A/B-1
Analog Output (standard)	
Output Levels	4-20 mA, 0-20 mA, 0-10 Vdc, -10 to +10 Vdc (user selectable)
Compliance, 4-20 mA	10V (0-500 ohm load)
Compliance, 0-10V	2 mA (5 kOhm load)
Output Resolution	16 bits (65,536 steps)
Output Accuracy	0.02% of output span
Output Update Rate	Programmed gate time + 30 ms + 0-2 signal periods
Output Isolation	250V rms working, 2.3 kV rms per 1 minute test
Serial Communications (standard)	
Signal Types	RS232 or RS485 (half or full duplex)
Data Rates	300, 600, 1200, 2400, 4800, 9600, 19200 baud
Output Isolation	250V rms working, 2.3 kV rms per 1 min test
Serial Protocols	Modbus RTU, Modbus ASCII, Laurel ASCII
Modbus Modes	RTU or ASCII
Modbus Compliance	Modbus over Serial Line Specification V1.0 (2002)
Digital Addressing	247 Modbus addresses. Up to 32 devices on an RS485 line without a repeater.
Dual Relay Output (standard)	
Relay Type	Two solid state relays, SPST, normally open, Form A
Load Rating	120 mA at 140 Vac or 180 Vdc
Sensor Excitation Output (standard)	
Output Levels	5V@100 mA, 10V@120 mA, 24V@50 mA (jumper selectable)
Output Isolation	50V from signal ground
Power Input	
Standard Power	85-264 Vac or 90-300 Vdc
Low Power Option	10-48 Vdc or 12-32 Vac
Power Frequency	DC or 47-63 Hz
Power Isolation	250V rms working, 2.3 kV rms per 1 min test
Power Consumption	2W typical, 3W with max excitation output
Mechanical	
Dimensions	129 x 104 x 22.5 mm case
Mounting	35 mm rail per DIN EN 50022
Electrical Connections	Plug-in screw-clamp connectors
Environmental	
Operating Temperature	0°C to 55°C
Storage Temperature	-40°C to 85°C
Relative Humidity	95% at 40°C, non-condensing
Cooling Required	Mount transmitters with ventilation holes at top and bottom. Leave 6 mm (1/4") between transmitters, or force air with a fan.



**Absolute
Gauge
Technologies™**

Presented by: Absolute Gauge Technologies
 sales@absolute-gauge.com; www.absolute-gauge.com,
 Toronto: 416 754 3168, Montreal: 514 695 5147, Toll Free: 1 888 754 7008

Pinout

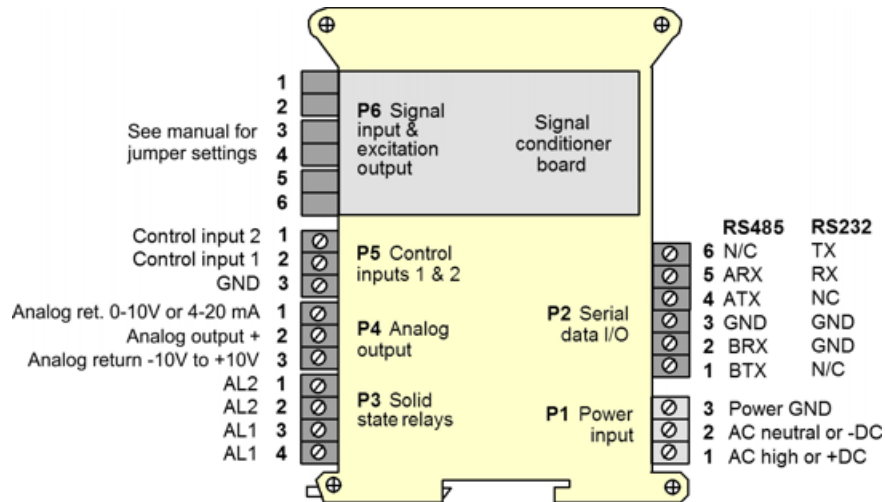

Mechanical

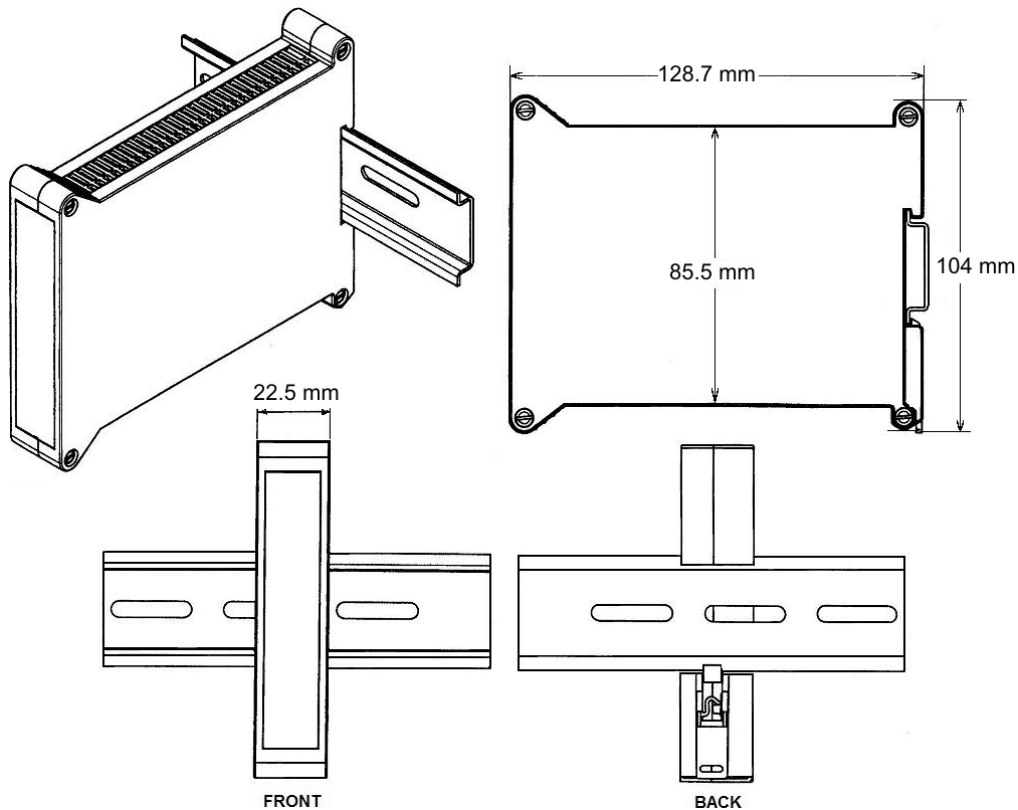

Application Examples of Frequency / Rate Meters & Transmitters

Controlling the Mixing Ratio of Two Fluids	
<p>Liquid A Liquid B</p>	<p>Transmitting and alarming the input flow rate ratio of two fluids (gas or liquid) allows these to be mixed in a predetermined ratio in continuous processes. The sensing element is normally a turbine flow meter, which outputs pulses at a frequency proportional to flow rate. The A/B ratio can also be transmitted for totalized rate (or delivered volume).</p>

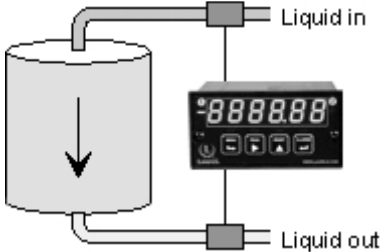
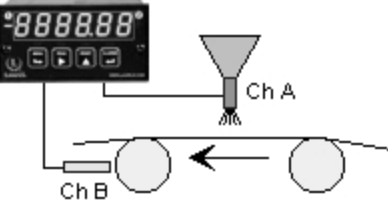
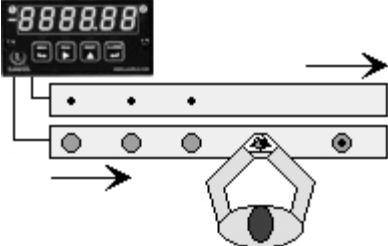
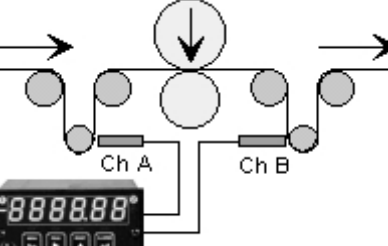

Comparing Fluid Inflow & Outflow	
	<p>The ratio of the inflow and outflow rates of a tank is a measure of the relative filling or emptying rate. The same transmitter can also be programmed to transmit the net inflow or outflow rate in flow units, or to transmit totalized inflow or outflow in volume units. Any of these parameters can be alarmed using the dual relay board and be transmitted as a 4-20 mA current loop and as serial data.</p>
Controlling Coating Thickness on a Film	
	<p>In this application, Channel A measures the rate at which a coating material is applied, as measured by a flow meter, while Channel B measures the speed of the film based on pulses from a proximity switch. Transmitting and alarming the A/B ratio assures that an even thickness of coating material is applied as the speed of the film is varies.</p>
Instrumenting a Pulsed Laser System	
	<p>The dual-channel Laureate transmitter can measure the speed of conveyor lines by using the output of proximity switches which sense gear teeth or spokes of rotating drive wheels. Transmitting the speed ratio of two lines allows line speeds to be adjusted so that material arrives at work stations when needed.</p>
Measuring Draw for Elongation	
	<p>Draw ($\text{Ch A} / \text{Ch B} - 1$) can be used to indicate the elongation of films compressed between rollers, the shrinkage films, and the RPM difference of rollers whose speed is varied to maintain tension. The high resolution of Laureate dual channel transmitters is ideal for comparison of rates that are close to each other.</p>

Ordering Guide

Create a model a model number in this format: **LT80FR, CBL04**

Transmitter Type	LT Laureate 4-20 mA & RS485 output transmitter
Main Board	8 Extended Main Board (required for arithmetic functions)
Power	0 Isolated 85-264 Vac or 90-300 Vdc 1 Isolated 12-32 Vac or 10-48 Vdc
Input Type	FR Dual-Channel Frequency
Accessories	CBL04 RS232 cable, 7ft. Connects RS232 screw terminals of LT transmitter to DB9 port of PC. CBL02 USB to RS232 adapter cable. Combination of CBL02 and CBL04 connects transmitter RS232 terminals to PC USB port.

