

REVISIONS					
REV.	ECN	DESCRIPTION	BY/DATE	CHK	APPR
B	5839	.31 WAS: .24	JS 03/12/09	RA	DV
C	8563	ADDED "MADE IN USA" MARKING	JS 04/27/12	LN	DV
D	9573	ADDED MOUNTING SCREW DYTRAN MODEL 6868 (2 PROVIDED)	RA, 02/08/13	LN	DV
E	11218	ADDED NOTE $\triangle 2$ & 2X 6688 M3 SCREW	EC 08/08/14	JS	EP

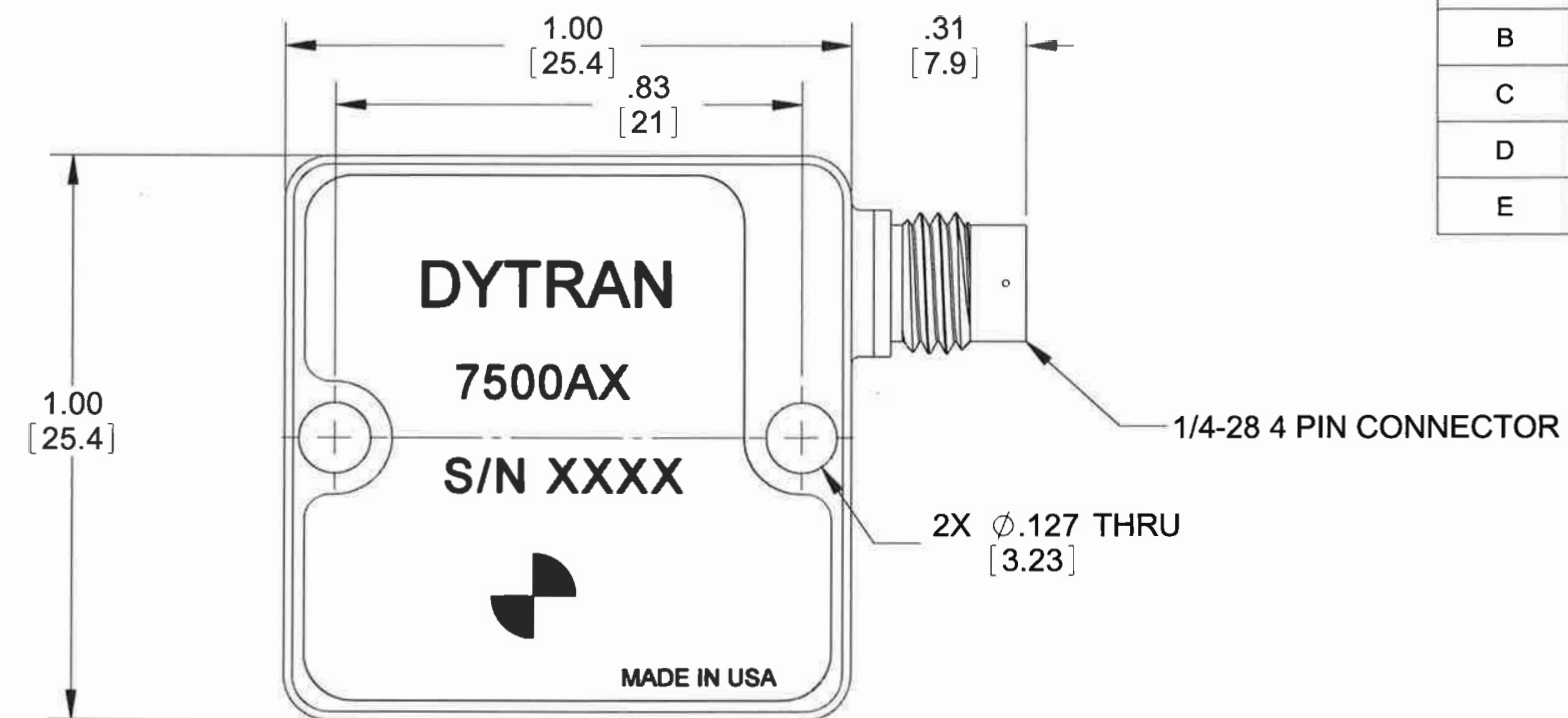

MODEL NO.	REV	ECN	RANGE
7500A1	E	11218	2g
7500A2	E	11218	5g
7500A3	E	11218	10g
7500A4	E	11218	25g
7500A5	E	11218	50g
7500A6	E	11218	100g
7500A7	E	11218	200g
7500A8	E	11218	400g

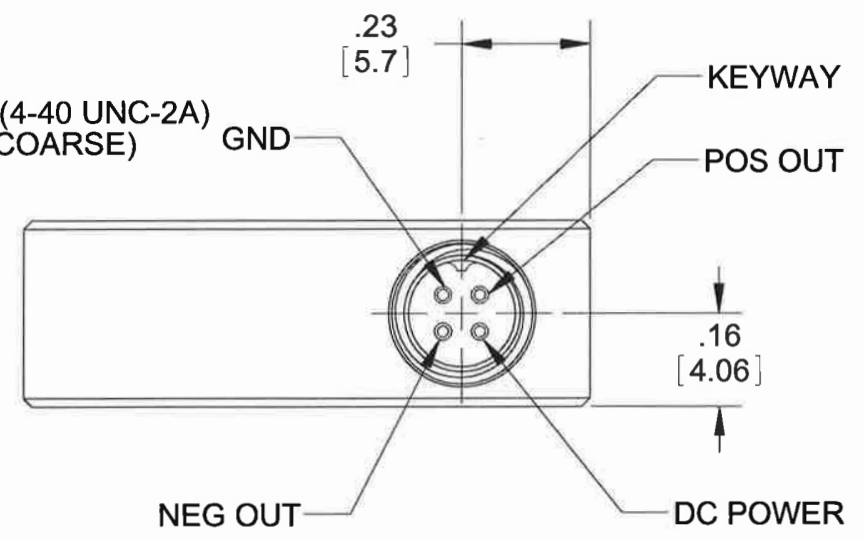
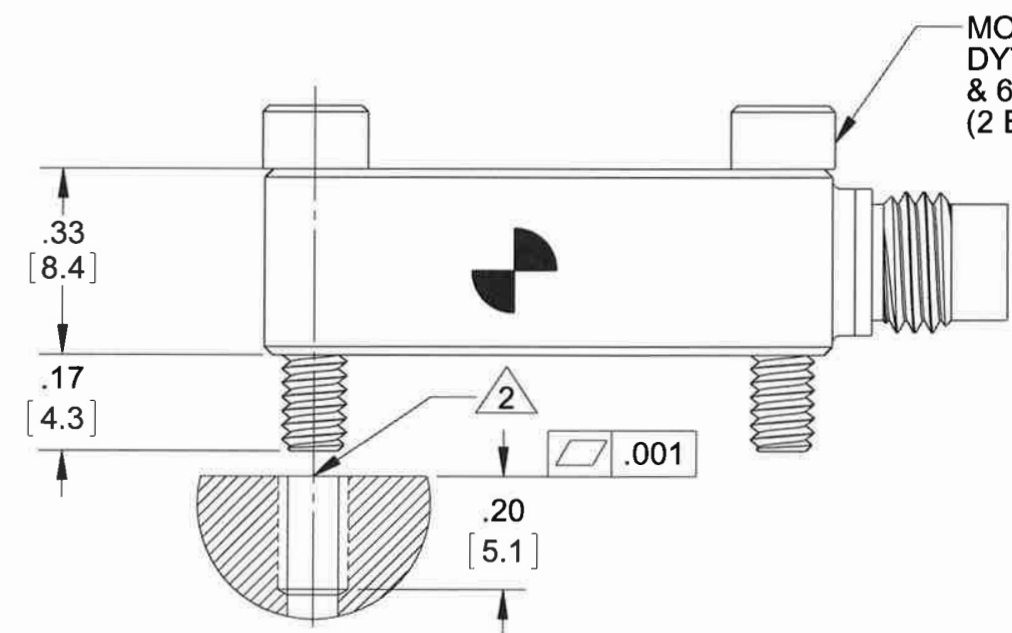

$\triangle 2$ MOUNTING RECOMENDATIONS:
 PREPARE A SURFACE TO A FLATNESS EQUAL OR BETTER THAN .0001 TIR. TAP 4-40 UNC-2B ∇ .200 MIN. OR TAP M3X.5 ISO 6H COARSE ∇ 5.1 MIN. RECOMMENDED TORQUE 10-12 LB-IN.

1. DIMENSIONS IN BRACKETS [X.XX] ARE IN MILLIMETERS.

NOTES: UNLESS OTHERWISE SPECIFIED

DRILL HOLE SIZE	TOLERANCE	UNLESS OTHERWISE SPECIFIED: INTERPRET DIM & TOL PER ASME Y14.5M - 1994. REMOVE BURRS. COUNTERSINK INTERNAL THDS 90° TO MAJOR DIA. CHAM EXT THDS 45° TO MINOR DIA. THD LENGTHS AND DEPTHS ARE FOR MIN FULL THDS. THDS PER MIL-S-7742. DIMENSIONS APPLY AFTER FINISHING.
.0135 THRU .125	+0.04 / -0.01	ALL MACHINED SURFACES: TOTAL RUNOUT WITHIN .005. BREAK SHARP EDGES .005 TO .010. MACHINED FILLET RADII .005 TO .015. WELDING SYMBOLS PER AWS A2.4. ABBREVIATIONS PER MIL-STD-12.
.1260 THRU .250	+0.005 / -0.001	
.2510 THRU .500	+0.006 / -0.001	
.5010 THRU .750	+0.008 / -0.001	
.7510 THRU 1.000	+0.010 / -0.001	
1.001 THRU 2.000	+0.012 / -0.001	

THIRD ANGLE PROJECTION USA

UNLESS OTHERWISE SPECIFIED: DIMENSIONS ARE IN INCHES. TOLERANCES ARE:		CONTRACT NO.	
DECIMALS .XX ± .010 .XXX ± .005	ANGLES ± 1°		
MATERIAL: TITANIUM	FINISH:	APPROVALS	DATE
		ORIG	TMD
		CHK	CES
		APP	CES
		APP	DV
DO NOT SCALE DRAWING			8/16/06
			05/23/07
			05/23/07
			02/18/13

DYTRAN MASTER INSTRUMENTS, INC. Chatsworth, CA

IF IN RED

TITLE: **OUTLINE/INSTALLATION DRAWING, VARIABLE CAPACITANCE ACCELEROMETER MODEL 7500A**

SIZE B	CAGE CODE 2W033	DWG NO 127-7500A	REV E
------------------	---------------------------	----------------------------	-----------------

SCALE: 4:1 SOLIDWORKS SHEET 1 of 1



- VARIABLE CAPACITANCE ACCELEROMETER
- DIFFERENTIAL MODE
- HERMETICALLY SEALED
- DC RESPONSE

This family also includes:

Model	Input Range (g)	Frequency response (Hz)	Sensitivity Differential, ±10% (mV/g)	Max.Shock (gpk)	Noise Differential (µg rms/√Hz)
7500A1	± 2	0-400	1,000	2000	8
7500A2	± 5	0-600	400	2000	9
7500A3	± 10	0-1000	200	2000	10
7500A4	± 25	0-1500	80	2000	25
7500A5	± 50	0-2000	40	2000	50
7500A7	± 200	0-2500	10	2000	200
7500A8	± 400	0-2500	5	2000	400

Refer to the performance specifications of the products in this family for detailed description.

Supplied Accessories:

- 1) Accredited calibration certificate (ISO 17025)
- 2) Two mounting screws model # 6868

Notes:

- [1] Single ended sensitivity is half of values shown.
- [2] Over the rated temperature range.
- [3] -90% to +90% of Full Scale.
- [4] In the interest of constant product improvement, we reserve the right to change specifications without notice.

PHYSICAL

Weight, Max
Connector Type
Mounting Thru Holes
Material

ENGLISH		SI	
0.46	oz	13	grams
4-PIN, 1/4-28 UNF-2A		4-PIN, 1/4-28 UNF-2A	
2 X Ø.13		2 X Ø.13	
Titanium Alloy		Titanium Alloy	

PERFORMANCE

Input Range
Frequency Response (-3dB), ± 50Hz
Sensitivity Differential, ±10% [1]
Output Noise, Differential, Typ
Non-Linearity, Max [3]
Transverse Sensitivity, Max
Scale Factor Calibration Error, Max

±100	g	±981	m/s ²
0 - 2500	Hz	0 - 2500	Hz
20	mV/g	2.0	mV/m/s ²
100	µg rms/√ Hz	981	µ m/s ² /√ Hz
1	% Span	1	% Span
2	%	2	%
2	%	2	%

ENVIRONMENTAL

Maximum Mechanical Shock
Bias Temperature Shift ,Max [2]
Bias Calibration Error
Operating Temperature Range
Scale Factor Temperature Shift [2]
Seal

2000	gpk	19620	m/s ² peak
56	(ppm of span)/°F	100	(ppm of span)/°C
1.5	% of span	1.5	% of span
-67 to +257	°F	-55 to +125	°C
-83.3 to +83.3	ppm/°F	-150 to +150	ppm/°C
Hermetic		Hermetic	

ELECTRICAL

Output Common Mode Voltage, TYP
Output Impedence, Nom
Operating Voltage
Operating Current (AOP & AON open)
Power Supply Rejection Ratio
Ground Isolation

2.45	VDC	2.45	VDC
1	Ω	1	Ω
+9 to +32	VDC	+9 to +32	VDC
12 to 14	mA DC	12 to 14	mA DC
>65	dB	>65	dB
>30	MΩ	>30	MΩ

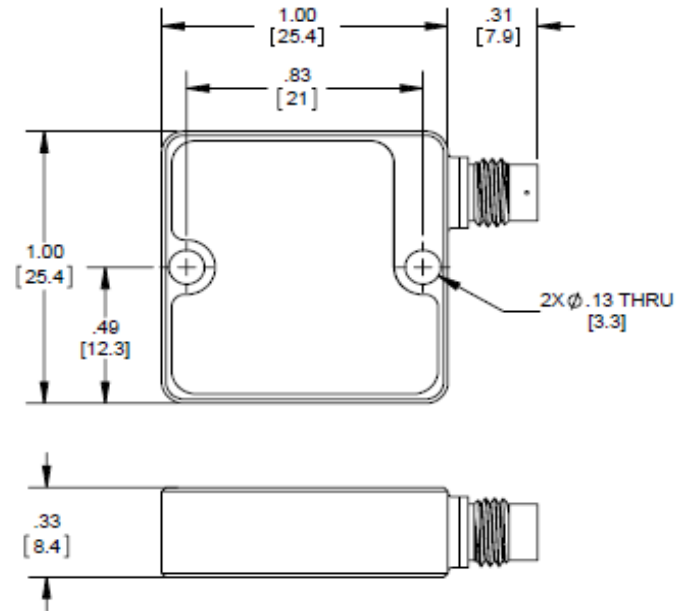

Units on the line drawing are in inches, dimensions in brackets [] are in millimeters. Refer to 127-7500A for more information.



21592 Marilla Street, Chatsworth, California 91311 Phone: 818.700.7818 Fax:818.700.7880 www.dytran.com
For permission to reprint this content, please contact info@dytran.com



Presented by: Absolute Gauge Technologies
sales@absolute-gauge.com; www.absolute-gauge.com,
Toronto: 416 754 3168, Montreal: 514 695 5147, Toll Free: 1 888 754 7008