

SCM7B36

Isolated Potentiometer Input Modules



Description

Each SCM7B36 Potentiometer input module provides a single channel of resistance input which is filtered, isolated, amplified, and converted to a high-level analog voltage output (Figure 1).

The SCM7B36 module interfaces to slidewires and potentiometers in both two or three wire configuration and incorporates a five-pole filtering approach to maximize both time and frequency response by taking advantage of both Bessel and Butterworth characteristics. One pole of the filter is on the field side of the isolation barrier; four are on the process control system side. In the 3-Wire configuration, lead resistance compensation is provided if the resistance of the "x" lead is closely equivalent to that of the "+" lead. Internal to the module, measurement error due to lead resistance is canceled.

In response to the low-level current excitation, and after initial field-side filtering, the input signal is chopped by a proprietary chopper circuit and transferred across the transformer isolation barrier, suppressing transmission of common mode spikes and surges. The signal is then reconstructed and filtered for process control system output.

Six standard input resistance ranges are offered, from 100Ω to 10kΩ, with three output ranges available: 0-5V, 1-5V, and 0-10V. Modules accept a wide 14-35VDC power supply range (+24VDC nominal). Their compact packages (2.13" x 1.705" x 0.605" max.) save space and are ideal for high channel density applications. They are designed for easy DIN rail mounting using any of Dataforth's "-DIN" backpanels.

► Features

- Industry's First 7B Potentiometer Input Module
- Interfaces 100Ω to 10kΩ Potentiometers
- Provides High-Level Voltage Outputs
- 1500Vrms Transformer Isolation
- Accuracy, ±0.03% of Span Typical, ±0.1% Max
- ANSI/IEEE C37.90.1 Transient Protection
- Input Protected to 120Vrms Continuous
- 120dB CMRR
- 85dB NMR at 60Hz, 80dB at 50Hz
- Easy DIN Rail Mounting
- CSA C/US Certified
- CE and ATEX Compliant

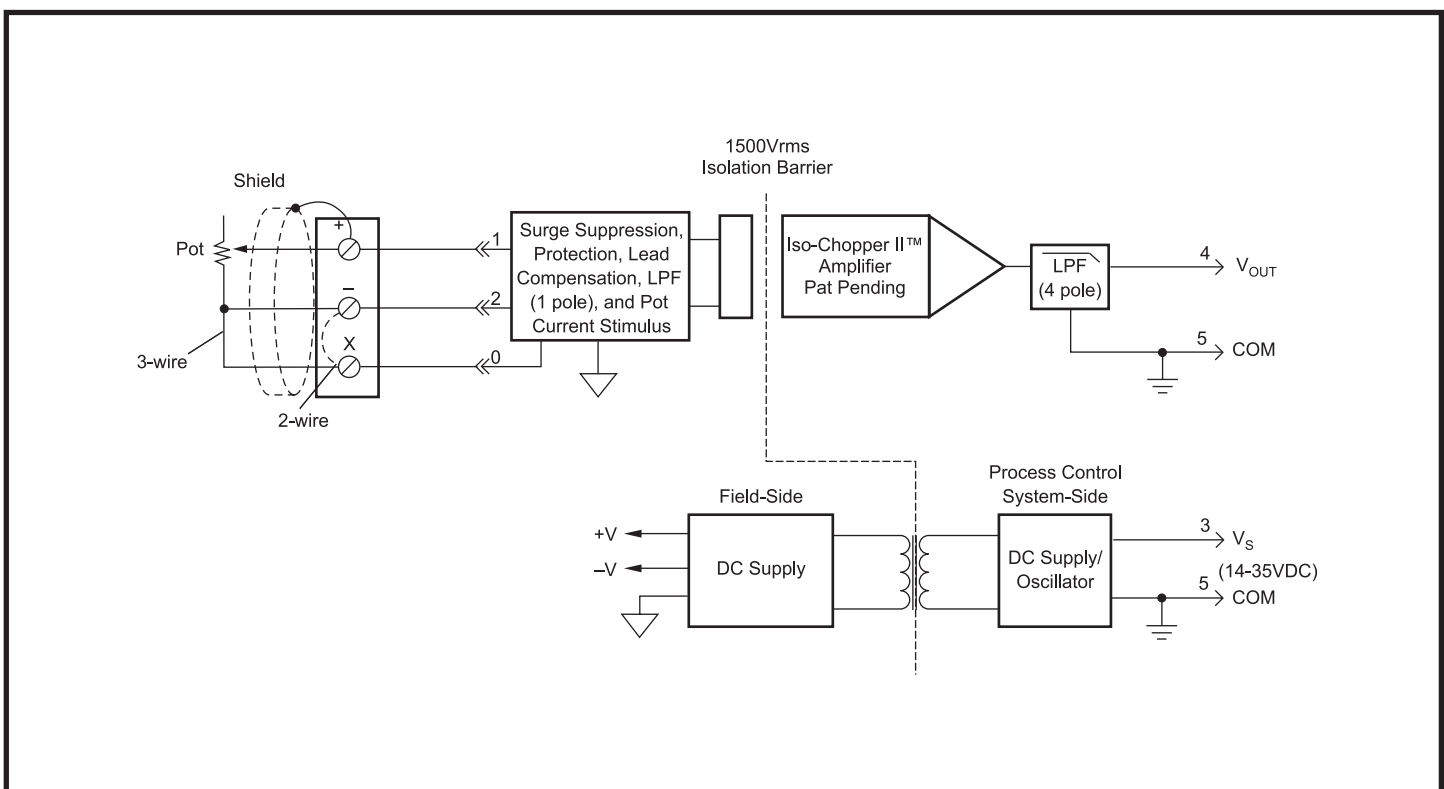

Figure 1: SCM7B36 Block Diagram

Specifications Typical* at 25°C and +24VDC

Module	SCM7B36
Input Range Protection Continuous Transient	(See Ordering Information) 120Vrms max ANSI/IEEE C37.90.1
Sensor Excitation Current Lead Resistance Effect (3-Wire) ⁽¹⁾	65µA (10kΩ) to 260µA (100Ω) -01 thru -04 : ±0.005Ω/Ω -05 : ±0.02Ω/Ω -06 : ±0.04Ω/Ω
Output Range ⁽²⁾ (See Output Range) Effective Available Power ⁽²⁾ Resistance Protection Voltage/Current Limit	† 40mW < 1Ω Continuous Short-to-Ground ±12V, ±14mA
CMV (Input to Output) Continuous Transient CMRR (50 or 60Hz)	1500Vrms ANSI/IEEE C37.90.1 120dB
Accuracy ⁽³⁾ Linearity ⁽⁴⁾	±0.03% Span typical, ±0.1% Span max ±0.01% Span typical, ±0.02% Span max
Stability (-40°C to +85°C) Input Offset Output Offset Gain	±0.01Ω/°C ±30µV/°C ±60ppm/°C
Noise Peak at 5MHz B/W RMS at 10Hz to 100kHz B/W Peak at 0.1Hz to 10Hz B/W	1mV 250µV 1µV RTI
Open Input Response '+' Lead '-' Lead 'x' Lead Open Input Detection Time	Upscale Non-deterministic Downscale <5s
Frequency and Time Response Bandwidth, -3dB NMR (50/60Hz) Step Response, 0 to 90%	3Hz 80/85dB 250ms
Supply Voltage Current ² Sensitivity	14-35VDC 12mA ±0.0001%/V _S
Mechanical Dimensions (h)(w)(d)	2.13" x 1.705" x 0.605", max 54.1mm x 43.3mm x 15.4mm max
Environmental Operating Temperature Range Storage Temperature Range Relative Humidity Emissions EN61000-6-4 Radiated, Conducted Immunity EN61000-6-2 RF ESD, EFT	-40°C to +85°C -40°C to +85°C 0 to 95% Noncondensing ISM, Group 1 Class A ISM, Group 1 Performance A ±0.5% Span Error Performance B

NOTES:

* Contact factory or your local Dataforth sales office for maximum values.

(1) Lead resistance effect is given for the condition of not having the NTC thermistor installed in the backpanel. As a general rule; as long as the lead resistance of the (+) lead matches the parallel combination of the thermistor and lead resistance in the (X) lead, the given specifications apply.

(2) Output Range and Supply Current specifications are based on minimum output load resistance. Minimum output load resistance is calculated by V_{out}^2/P_E , where P_E is the output Effective Available Power that guarantees output range and accuracy specifications.

(3) Accuracy includes the effects of repeatability, hysteresis, and linearity, but does not include sensor accuracy.

(4) Linearity is calculated using the best-fit straight line method.

Ordering Information

Model	Input Range
SCM7B36-01	0 to 100Ω
SCM7B36-02	0 to 200Ω
SCM7B36-03	0 to 500Ω
SCM7B36-04	0 to 1kΩ
SCM7B36-05	0 to 5kΩ
SCM7B36-06	0 to 10kΩ

†Output Ranges Available

Output Range	Part No. Suffix	Example
+1 to +5V	NONE	SCM7B36-01
0 to +5V	A	SCM7B36-01A
0 to +10V	D	SCM7B36-01D