

MV-SC5120XC-00C-NNN

12 MP Smart Camera



Introduction

MV-SC5120XC-00C-NNN smart camera is developed based on high-performance embedded platform with strong calculation performance. It integrates VM functions and AI deep learning algorithm, and can use more than 140 algorithms. It adopts multiple interfaces for supporting monitor, keyboard, mouse, etc.

Available Model

MV-SC5120XC-00C-NNN

Applicable Industry

Consumer electronics, food and pharmaceutical, packaging, etc.

Key Features

- Adopts AI deep learning algorithm to achieve OCR, object recognition, defect detection, etc.
- Integrates VM functions and supports more than 140 algorithms.
- Adopts multiple I/O interfaces, such as multiple input/output signals.
- Supports multiple communication protocols.
- Supports indicators displaying device status for easy debugging and maintenance.
- Supports ingress protection IP67.

Specification

Model	MV-SC5120XC-00C-NNN
Tool	
Function module	Vision Master Platform (include deep learning module)
Communication protocol	TCP, UDP, Modbus, Serial Port, PROFINET, EtherNet/IP, Fins, MC, FTP, etc.
Camera	
Sensor type	CMOS, global shutter
Pixel size	3.45 μm \times 3.45 μm
Sensor size	1/1.1"
Resolution	4096 \times 2944
Max. frame rate	30 fps
Gain	0 dB to 37 dB
Exposure time	45 μs to 1 sec
Pixel format	Mono 8, RGB 8
Mono/color	Color
Platform	
Memory	8 GB
Storage	64 GB
Electrical feature	
Data interface	Gigabit Ethernet (1000 Mbit/s)
Digital I/O	12-pin M12 connector provides power and I/O, including opto-isolated input \times 3 (Line 0/1/2), opto-isolated output \times 3 (Line 3/4/5), and RS-232 \times 1
Power supply	24 VDC
Power consumption	Typ. 10 W @ 24 VDC Max. 14.4 W @ 24 VDC
Mechanical	
Lens mount	C-mount
Lens cap	Transparent lens cap
Light source	Not included
Indicator	Power indicator (PWR), network indicator (LNK), and user-defined indicator (U1/U2)
Dimension	Straight angle: 112.3 mm \times 54 mm \times 110 mm (4.4" \times 2.1" \times 4.3") Right angle: 88.7 mm \times 54 mm \times 110 mm (3.5" \times 2.1" \times 4.3")
Weight	Approx. 370 g (0.8 lb.)
Ingress protection	IP67 (under proper installation of waterproof lens cap)
Temperature	Working temperature: 0 $^{\circ}\text{C}$ to 50 $^{\circ}\text{C}$ (32 $^{\circ}\text{F}$ to 122 $^{\circ}\text{F}$) Storage temperature: -30 $^{\circ}\text{C}$ to 70 $^{\circ}\text{C}$ (-22 $^{\circ}\text{F}$ to 158 $^{\circ}\text{F}$)
Humidity	20% RH to 95% RH (no condensation)
General	
Certification	CE, KC

Dimension

Device (Straight Angle):

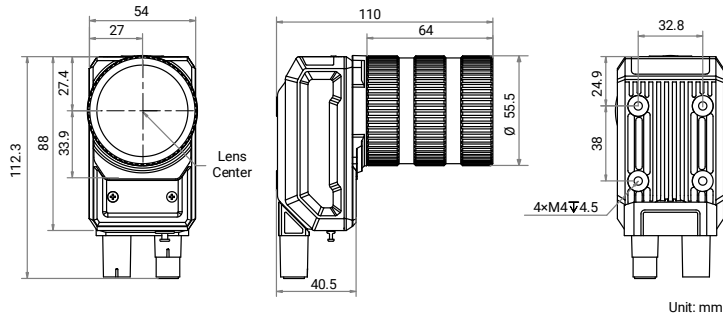

Device (Right Angle):

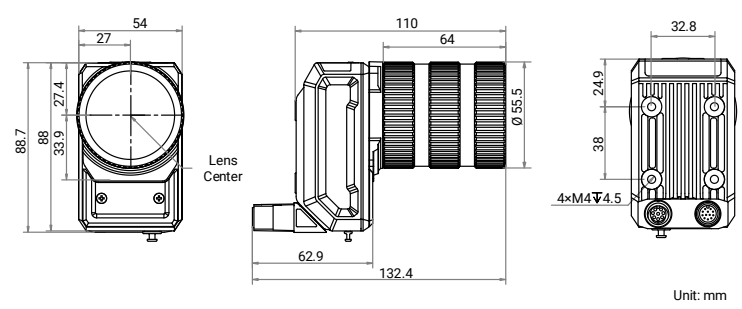

Device and Installation Bracket (Straight Angle):

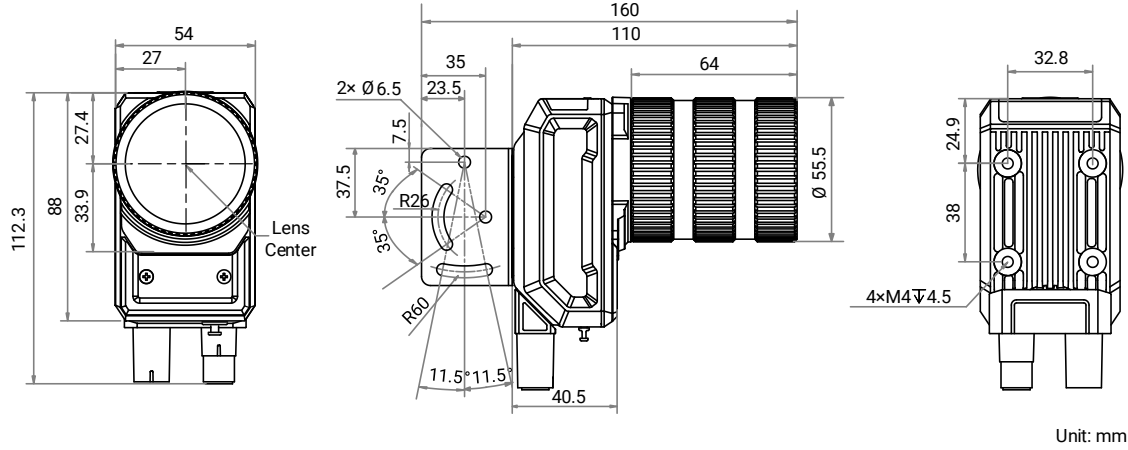

Device and Installation Bracket (Right Angle):

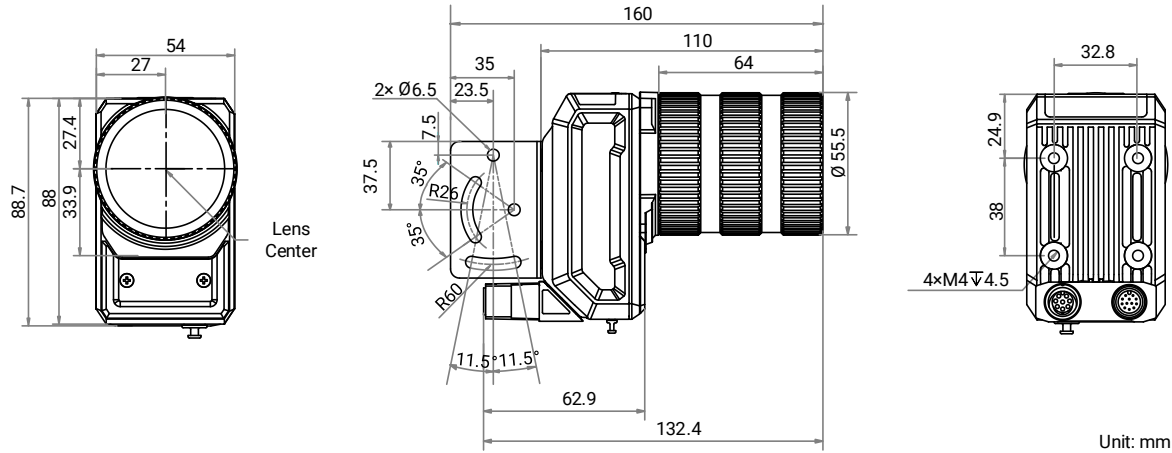

Installation Bracket:

