

DR-2500

**Drehmomentsensor, Analogausgang -
Torque Sensor, Analog Output**

- Aktiver Ausgang $\pm 5\text{ V}$ - Active output $\pm 5\text{ V}$
- Messrate 10 kSample - Sample rate 10 kSample

DR-2600

**Drehmomentsensor, RS485-Schnittstelle -
Torque Sensor, RS485-Interface**

- RS485-Schnittstelle - RS485-Interface
- Auto-Identifikation von: Messbereich, Serien- Nr., Kalibrierdatum - Auto identification of: measuring range, serial number, date of calibration
- Messrate 5 kSample - Sample rate 5 kSample



Diese Sensoren haben eine berührungslose und digitale Signalübertragung von Rotor zu Stator, also ohne Signalverfälschung und wartungsfrei.

These sensors have a contactless and digital signal transmission from rotor to stator, which means no signal falsification and maintenance-free.

Artikel-Nr. Article-no. DR-2500	Artikel-Nr. Article-no. DR-2600	Messbereich Measuring range [N·m]	Max. Drehzahl Max. speed [min ⁻¹]	Federkonstante Springrate [N·m/rad]	Massen- trägheits- moment Mass moment of inertia [kg·m ²]		Max. Axiallast Max. thrust load [N]
					Antriebsseite Drive side	Messseite Test side	
107606	107951	0,005	20000	4,6·10 ⁻¹	7,5·10 ⁻⁷	1,1·10 ⁻⁸	3
107607	108095	0,01	20000	4,6·10 ⁻¹	7,5·10 ⁻⁷	1,1·10 ⁻⁸	3
107428	108096	0,02	30000	3,7	7,6·10 ⁻⁷	1,3·10 ⁻⁸	10
107429	108097	0,05	30000	3,7	7,6·10 ⁻⁷	1,3·10 ⁻⁸	10
107430	108098	0,1	30000	1,7·10 ¹	7,6·10 ⁻⁷	1,3·10 ⁻⁸	15
107431	108124	0,2	30000	1,7·10 ¹	7,6·10 ⁻⁷	1,3·10 ⁻⁸	20
107432	108278	0,5	30000	9,8·10 ¹	7,6·10 ⁻⁷	1,3·10 ⁻⁸	30
107433	108530	1	30000	9,8·10 ¹	7,6·10 ⁻⁷	1,3·10 ⁻⁸	40
107434	108093	2	30000	5,0·10 ²	9,1·10 ⁻⁷	8,3·10 ⁻⁸	50
107435	108358	5	30000	5,0·10 ²	9,1·10 ⁻⁷	8,3·10 ⁻⁸	50
107436	108359	10	30000	5,8·10 ²	9,7·10 ⁻⁷	1,5·10 ⁻⁷	50
107598	108279	20	20000	4,9·10 ³	1,2·10 ⁻⁵	3,6·10 ⁻⁶	100
107599	108280	50	20000	9,3·10 ³	1,2·10 ⁻⁵	3,9·10 ⁻⁶	200
107600	108094	100	20000	9,3·10 ³	1,2·10 ⁻⁵	3,9·10 ⁻⁶	200
109190	109253	150	20000	1,1·10 ⁴	1,2·10 ⁻⁵	4,2·10 ⁻⁶	200

Bei der Bestellung bitte den gewünschten Messbereich angeben! Please specify the required meas. range at order!



Presented by: Absolute Gauge Technologies
 sales@absolutegauge.com; www.absolutegauge.com,
 Toronto: 416 754 3168, Montreal: 514 695 5147, Toll Free: 1 888 754 7008

TECHNISCHE DATEN - SPECIFICATIONS

Typ - Type		DR-2500	DR-2600
Genauigkeitsklasse - Accuracy class	% v. E. - f. s.	0,1	
Reproduzierbarkeit - Repeatability (DIN 1319)	%	±0,02	
Versorgung - Excitation voltage	V DC	12 ... 28	
Stromaufnahme - Current consumption	mA	<60	
Ausgangssignal - Output signal		0 ... ±5 V	±25000 digits
Belastbarkeit - Output current max.	mA	5 kurzschlussfest short circuit resist.	
Eingang Kontrollaufschaltung - Calibration control	V	L <2,0; H >3,5	per Software
Messrate - Sample rate	kSample	10	5
Referenztemperatur - Reference temperature	°C	+23	
Nenntemperaturbereich - Nominal temperature range	°C	+5 ... +45	
Gebrauchstemperaturbereich - Service temperature range	°C	0 ... +60	
Lagerungstemperaturbereich - Storage temperature range	°C	-10 ... +70	
Temp. koef. des Kennwertes - Temp. coeff. of sensitivity	% v. E./K - f. s./K	±0,01	
Temp. koef. des Nullsignals - Temp. coeff. of zero signal	% v. E./K - f. s./K	±0,02	
Gebrauchsdrehmoment (statisch) - Service torque (static)	% v. E. - f. s.	150	
Grenzdrehmoment (statisch) - Limit torque (static)	% v. E. - f. s.	200	
Bruchdrehmoment (statisch) - Ultimate torque (static)	% v. E. - f. s.	>300	
Schwingbreite - Bandwidth (DIN 50100)	%	70 (Spitze-Spitze) - (peak-peak)	
Schutzart - Level of protection (DIN EN 60529)		IP50	
Elektrischer Anschluss - Electrical connection		8-polig Serie 711 - 8-pin series 711	

Optionen - Options

Artikel- Nr. - Article-no.	Bezeichnung - Description		
107437	Drehzahlmessung - Speed control	Impulse - Impulses	6
103562	Ausgangssignal - Output signal	V	0 ... ±10

Anschlussbelegung - Pin connection

8-polig - 8-pin	DR-2500	
Pin 1	Versorgung (+) - Excitation (+)	12 ... 28 V DC
Pin 2	Versorgung (GND) - Excitation (GND)	0 V
Pin 3	Signal (+) - Signal (+)	±5 V
Pin 4	Signal (GND) - Signal (GND)	0
Pin 5	Kontrolle - Calibration control	L <2,0 V; H >3,5 V
Pin 6	Drehzahl - Speed	TTL
Pin 7	NC	-
Pin 8	NC	-
8-polig - 8-pin	DR-2600	
Pin 1	Versorgung (+) - Excitation (+)	12 ... 28 V DC
Pin 2	Versorgung (GND) - Excitation (GND)	0 V
Pin 3	RS485	RS485 (A)
Pin 4	RS485	RS485 (B)
Pin 5	Kontrolle - Calibration control	NC
Pin 6	Drehzahl - Speed	TTL
Pin 7	NC	-
Pin 8	NC	-

Mechanische Abmessungen - Dimensions

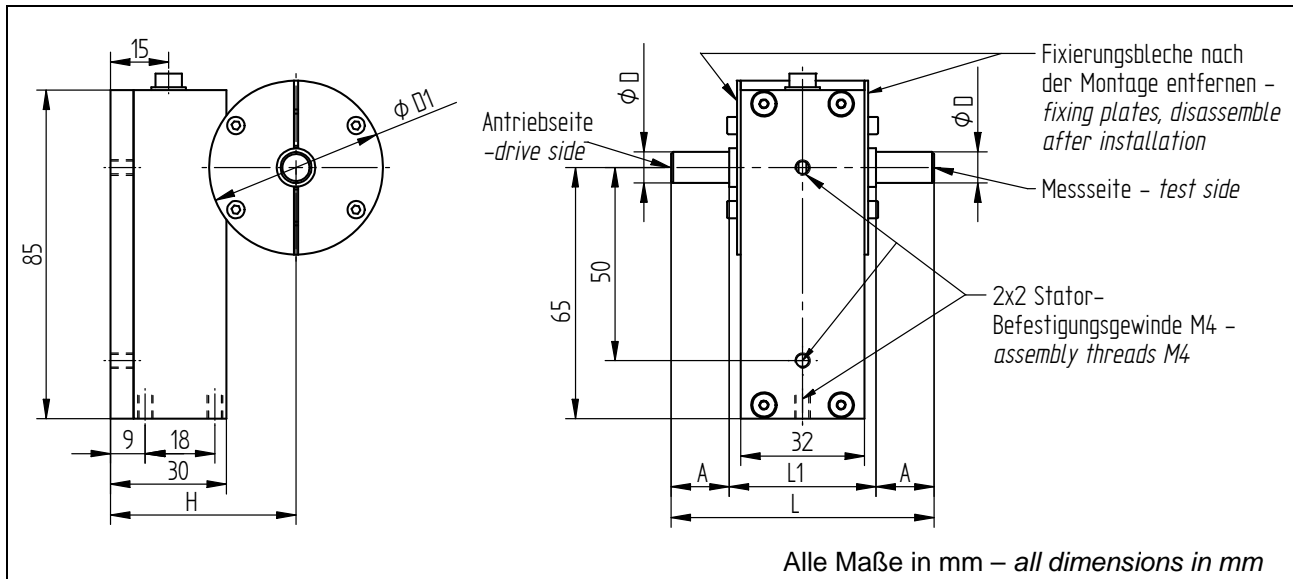

Messbereich - Measuring range [N·m]	Abmessungen - Dimensions [mm]					
	ϕD	$\phi D1$	A	L	L1	H
0,005 / 0,01	4 g6	45	5	48	38	48
0,02 / 0,05 / 0,1 / 0,2 / 0,5 / 1	6 g6	45	7	52	38	48
2 / 5	8 g6	45	15	68	38	48
10	10 g6	45	15	68	38	48
20 / 50 / 100 / 150	18 g6	59,5	36	122	50	53