

MV-CS060-10GM/GC-PRO

6 MP 1/1.8" CMOS GigE Area Scan Camera



GEN<i>i>CAM

GigE VISION

Introduction

With GigE interface, MV-CS060-10GM/GC-PRO camera adopts Sony® IMX178 sensor to provide high-quality image and transmit images in real time. Its max. frame rate can reach 19.1 fps in full resolution, and reach 30.7 fps when the image compression mode is enabled.

Key Feature

- Adopts brand new design to reduce power consumption.
- Supports image compression mode and noise reduction function.
- Compact design with mounting holes on panels for flexible mounting from 4 sides.
- Adopts GigE interface and max. transmission distance of 100 meters without relay.
- Compatible with GigE Vision V2.0 Protocol, GenICam Standard, and third-party software based on the protocol and standard.

Dimension

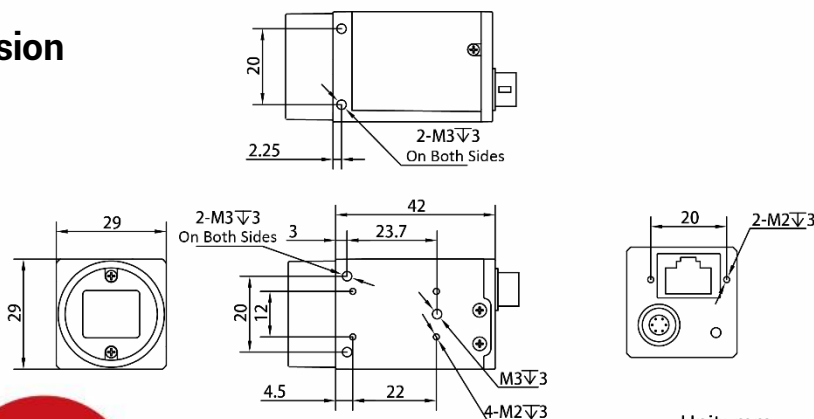

Unit: mm

Available Model

- Mono camera: MV-CS060-10GM-PRO
- Color camera: MV-CS060-10GC-PRO

Applicable Industry

SMT/ PCB AOI, consumer electronics, electrical semiconductor, etc.

Sensor Quantum Efficiency

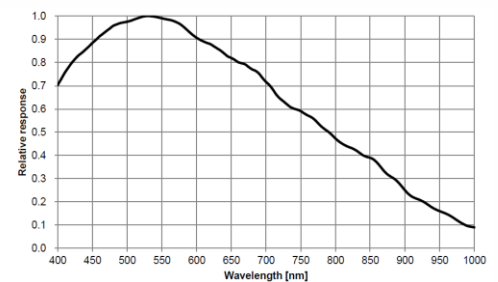

MV-CS060-10GM-PRO

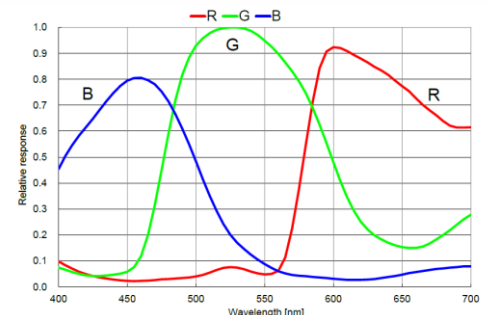

MV-CS060-10GC-PRO



Specification

Model	MV-CS060-10GM-PRO	MV-CS060-10GC-PRO
Camera		
Sensor type	CMOS, rolling shutter	
Sensor model	Sony® IMX178	
Pixel size	2.4 μm × 2.4 μm	
Sensor size	1/1.8"	
Resolution	3072 × 2048	
Max. frame rate	19.1 fps @3072 × 2048	
	30.7 fps @3072 × 2048 (image compression mode enabled)	
Dynamic range	71.3 dB	
SNR	41.3 dB	
Gain	0 dB to 24 dB	
Exposure time	25 μs to 2.5 sec	
Exposure mode	Off/Once/Continuous exposure mode, supports Global Reset, Trigger Rolling, and Rolling	
Mono/color	Mono	Color
Pixel format	Mono 8/10/10p/12/12p	Mono 8/10/12, Bayer RG 8/10/10p/12/12p, YUV422Packed, YUV422_YUYV_Packed, RGB 8, BGR 8
Binning	Supports 1 × 1, 2 × 2	
Decimation	Supports 1 × 1, 2 × 2, 4 × 4	
Reverse image	Supports horizontal and vertical reverse image output	
Electrical features		
Data interface	Gigabit Ethernet, compatible with Fast Ethernet	
Digital I/O	6-pin Hirose connector provides power and I/O, including opto-isolated input × 1 (Line 0), opto-isolated output × 1 (Line 1), bi-directional non-isolated I/O × 1 (Line 2).	
Power supply	9 VDC to 24 VDC, supports PoE	
Power consumption	Typ. 2.4 W@12 VDC	Typ. 2.5 W@12 VDC
Mechanical		
Lens mount	C-Mount	
Dimension	29 mm × 29 mm × 42 mm (1.1" × 1.1" × 1.7")	
Weight	Approx. 100 g (0.22 lb.)	
Ingress protection	IP40 (under proper lens installation and wiring)	
Temperature	Working temperature: -30 °C to 60 °C (-22 °F to 140 °F)	
	Storage temperature: -30 °C to 70 °C (-22 °F to 158 °F)	
Humidity	20% to 95% RH, non-condensing	
General		
Client software	MVS or third-party software meeting with GigE Vision Protocol	
Operating system	32/64-bit Windows XP/7/10, 32/64-bit Linux and 64-bit MacOS	
Compatibility	GigE Vision V2.0, GenICam	
Certification	CE, RoHS, KC	



Hangzhou Hikrobot Co., Ltd.
 en.hikrobotics.com