

## Hollow-Shaft Conductive Plastic Potentiometric Sensors

WAL300/305 Series



### Special features

- hollow shaft
- low-cost
- $4 \times 10^6$  movements
- very high resolution – better than  $0.3^\circ$

Careful selection of materials and high-quality components ensure a constant and accurate angle measurement throughout the entire service life of the sensor.

Special designs with other angular ranges are available on request.

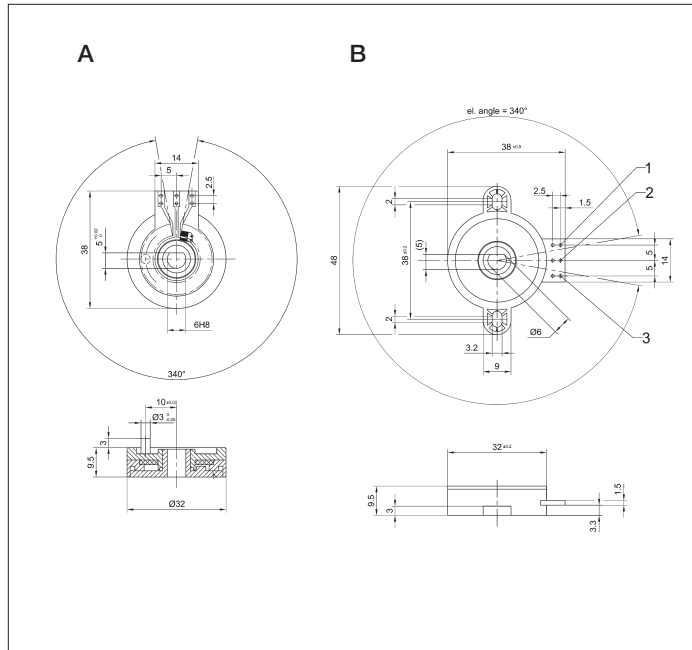

### Description

|                        |                                   |
|------------------------|-----------------------------------|
| Size                   | housing diameter 32 mm            |
| Housing                | Thermoplast                       |
| Bearings               | sleeve bearings                   |
| Resistance element     | conductive plastic                |
| Wiper assembly         | precious metal multi-finger wiper |
| Electrical connections | soldering pads                    |

| Type designations  | WAL300  | WAL305        |
|--|---|---------------|
| <b>Mechanical Data</b>   |   |               |
| Dimensions   | see drawing A   | see drawing B |
| Mechanical travel  | continuous  | °             |
| Permitted shaft loading (axial and radial) static or dynamic force | 1   | N             |
| Torque   | ≤ 1   | Ncm           |
| Maximum operational speed  | 120   | RPM           |
| Weight   | 8   | g             |
| <b>Electrical Data</b>   |   |               |
| Actual electrical travel   | 340   | °             |
| Resistance value   | 5   | kΩ            |
| Resistance tolerance   | ±20   | %             |
| Repeatability  | 0.09 (=0.3°)  | %             |
| Effective temperature coefficient of the output-to-applied voltage | 5 (typical)   | ppm/K         |
| Independent linearity  | ±2  | %             |
| Max. permissible applied voltage                                   | 35  | V             |
| Recommended operating wiper current                                | ≤ 1   | μA            |
| Max. wiper current in case of malfunction                          | 5   | mA            |
| Insulation resistance (500 VDC, 1 bar, 2 s)                        | ≥ 10,000  | MΩ            |
| Dielectric strength (AC, 50 Hz, 1 min, 1 bar)                      | 500   | V             |
| <b>Environmental Data</b>  |   |               |
| Temperature range  | -25...+75   | °C            |
| Vibration  | 50...500<br>A <sub>max</sub> = 0.75<br>a <sub>max</sub> = 2 | Hz<br>mm<br>g |
| Life   | 4 x 10 <sup>6</sup>   | movements     |
| Shock (DIN IEC 68 T2-27)   | 50<br>10  | g<br>ms       |
| Protection class (DIN 40050)                                       | IP 50   |               |

| <b>Order designations</b> |          |         |
|---------------------------|----------|---------|
| Type                      | Art. no. | R in kΩ |
| WAL300 5K0 1A             | 82920    | 5       |
| WAL305 5K0 1A             | 82871    | 5       |

**Order designations / Abbreviations**

1A: soldering pads

**Recommended accessories**  
 MAP process-control indicators and display. MUP signal conditioner for standardized output signals.

**Important**

All values given for this series – including linearity, lifetime, micro-linearity, resistance to external disturbances and temperature coefficient in voltage dividing mode – are quoted for the device operating with the wiper voltage driving an operational amplifier working as a voltage follower where virtually no load is applied to the wiper (I<sub>e</sub> ≤ 1 μA).