

MVL-HF3028M-6MPE 1/1.8" 30mm 6MP FA LENS

HF-E series FA Lens are optimized for machine vision light sources and sensor, with high resolution, excellent image quality, high transmittance and good stability. Featured with fixed focal length, manual aperture and compact size, it is suitable for machine vision industry applications and ideal for industrial cameras.



Key Features

- Higher image clarity and contrast ratio
- Ultra-low distortion and higher relative illumination rate
- Good optical performance at ultra-short working distance
- Compact design, convenient for device integration

Distortion

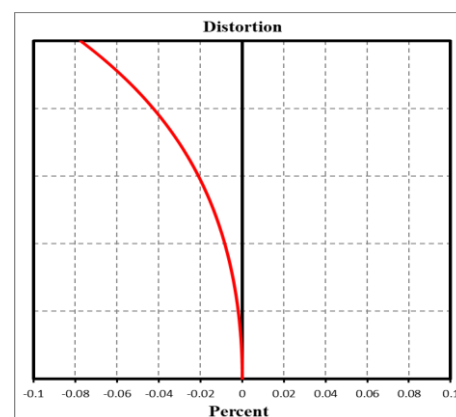

MTF

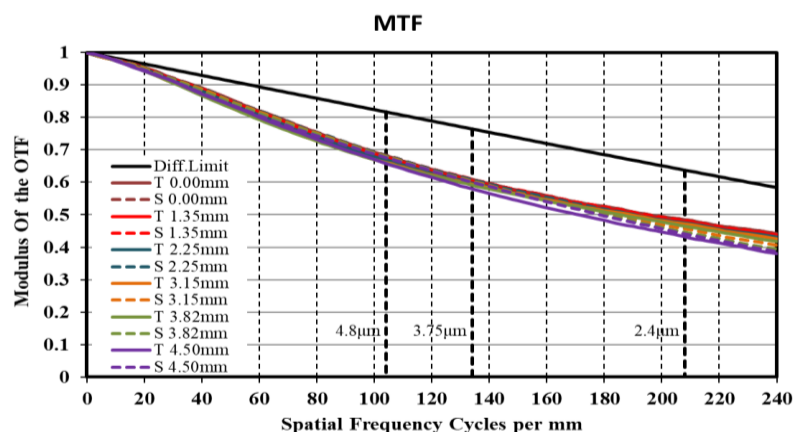

Relative Illumination

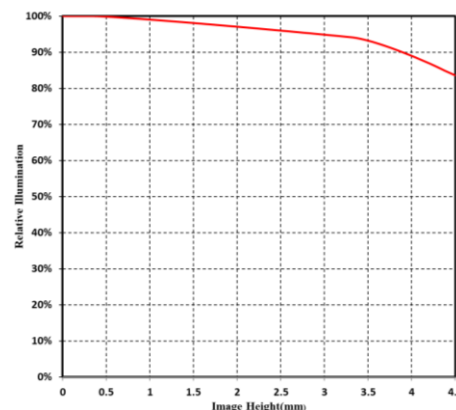

Note: The above curves are the simulate results based on F2.8, $\beta=-0.0603$, WD=500 mm.



Specification

Model	MVL-HF3028M-6MPE
Parameter	Fixed focal length, Manual iris, 6MP, FA Lens
Performance	
Focal Length	30 mm
F-Number	F2.8 ~ F16
Image Size	Φ9 mm(1/1.8")
Distortion	-0.031%
Minimum Object Distance	0.2 m
Field of View	D (8.96mm) : 16.99° H (7.38mm) : 14.01° V (4.92mm) : 9.38°
Mechanical	
Iris Control	Manual
Focus Control	Manual
Filter Thread	M27 × P0.5
Mount	C-Mount
Flange Back Length	17.526 mm
Dimension	Φ33 × 29.4 mm
Weight	49.2 g
Temperature	-10 ~ 50°C
General	
Certification	RoHS2.0

Dimension

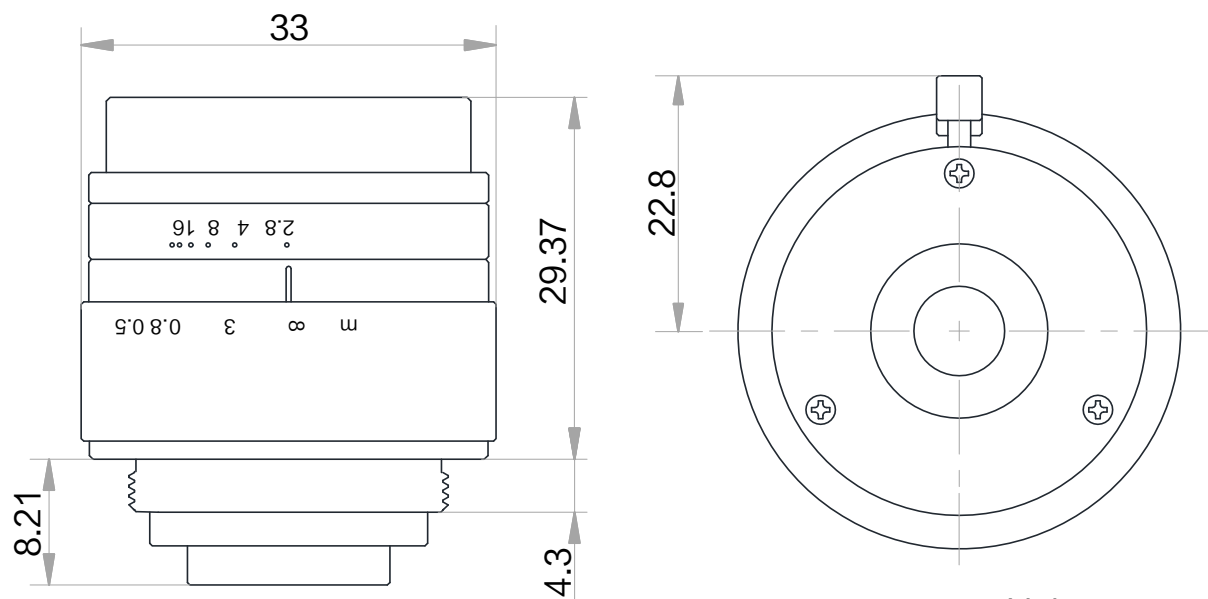

Unit: mm

Field of View

Extension (mm)	Working Distance (mm)		Magnification	Field of View (mm)			
				1/1.8"		1/2"	
				H(7.38mm)	H(4.92mm)	H(6.22mm)	V(4.67mm)
10	near	62	-0.514	14.43	9.60	12.15	9.11
	far	111	-0.296	25.20	16.72	21.18	15.86
5	near	92	-0.329	22.57	15.01	19.00	14.25
	far	225	-0.148	50.03	33.29	42.12	31.59
2	near	134	-0.217	34.16	22.74	28.77	21.58
	far	569	-0.059	124.40	82.96	104.86	78.75
1	near	160	-0.179	41.26	27.47	34.75	26.07
	far	1141	-0.030	248.18	165.64	209.29	157.24
0		200	-0.142	52.09	34.69	43.88	32.93
		250	-0.115	64.29	42.82	54.16	40.64
		300	-0.097	76.21	50.76	64.20	48.18
		350	-0.084	87.94	58.58	74.09	55.60
		400	-0.074	99.52	66.31	83.85	62.94
		450	-0.067	111.00	73.97	93.53	70.21
		500	-0.060	122.40	81.57	103.14	77.43
		550	-0.055	133.73	89.14	112.70	84.61
		600	-0.051	145.00	96.66	122.20	91.75
		650	-0.047	156.23	104.16	131.67	98.86
		700	-0.044	167.42	111.63	141.11	105.95
		800	-0.039	189.70	126.50	159.90	120.08
		900	-0.035	211.88	141.31	178.61	134.14
	1000	-0.032	233.98	156.07	197.26	148.15	

HIKROBOT

Hangzhou Hikrobot Co. Ltd.
 en.hikrobotics.com

© Hangzhou Hikrobot Co., Ltd. All Rights Reserved.

Hangzhou Hikrobot does not tolerate any infringement. Any organization or individual may not imitate or reproduce in whole or in part of the content. The data herein is based on Hikrobot's internal evaluation. Actual data may vary depending on specific configuration and operating condition. The information herein is subject to change without notice. All the content has been checked conscientiously. Nevertheless, Hikrobot shall not be liable to damages resulting from errors, inconsistencies or omissions.