

TOSHIBA MACHINE

COMPO ARM
ARM ROBOT

BA-III SERIES

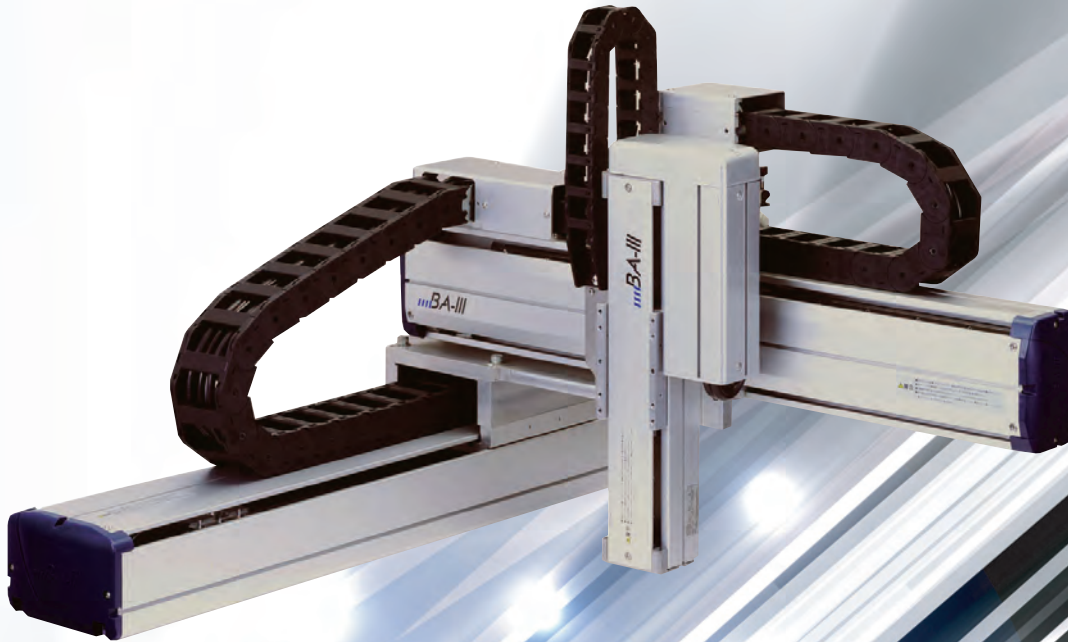

COMPO ARM

BA-III

Launched in 1986, the Cartesian robot COMPO ARM has developed a proven track record among many devoted customers because of its features of high reliability and ease of operation. For this reason, today, it is used as an integral part in many different types of production lines.

The new BA-III series carries on the features of the previous BA-II series while also providing enhanced functions for even greater ease of operation. Models are available from single-axis to Cartesian axes (2 to 4 axes) and in a wide range of variations for also meeting the future needs of customers.

● High load

<Maximum loadable weight>

Single-axis specifications: Horizontal 250 kg, Vertical 100 kg, X-Y2 axis combination specifications: 100 kg

*When driven by BE60J ball screw

● Long stroke

<Maximum stroke>

Maximum stroke: 4450 mm *When driven by BE60J timing belt

● High tact

<Maximum speed>

Driven by ball screw: 1200 mm/s, Driven by timing belt: 2000 mm/s

● High accuracy

<Position repeatability>

Driven by ball screw (grinding ball screw grade C7): ± 0.01 mm, Driven by timing belt: ± 0.04 mm

● Absolute specifications for all models

Includes AC servomotor not requiring home return (absolute specifications)

Robot Features

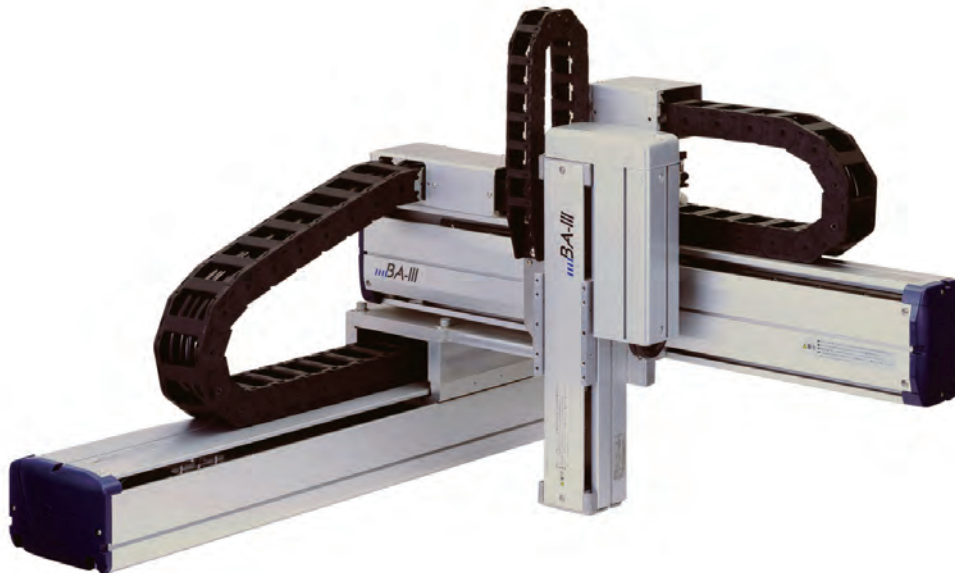

BA-III series aims for even greater ease of operation!

● Oilless seals are used in the LM guide and ball screw for enabling maintenance-free operation over extended periods of time.

● Compact AC servomotor is installed for enabling a shorter total axis length.

● Models with long strokes were added to the line-up for expanding the robot operating range.

Controller Features



CA25-M10



CA25-M40
CA25-M80



For four-axis

Enhanced Functions!

- A high-performance servo control engine is used to enable handling of even complex sealing work.
- A special line-up of controllers for high loads (motor capacity: 750 W) is available for reducing the cost of high-load systems.
- A master unit with a built-in driver for one axis can handle up to a maximum of four control axes (two axes in previous models) for eliminating the need for a high-function master unit, which was required for 3- and 4-axis combinations before. This enables lower costs and reduced space requirements.
- The processing speed of the controller has been increased for further reducing the cycle time.
- The "external point designation mode" has been enhanced so that after positioning is completed, external output of the point table number is possible.
 - * "External point designation mode" is an operation mode that performs positioning operation by output signals from the PLC or other device without using commands.

CONTENTS

ROIbot Line-up	2
Type Selection	7
Single Axis Specifications	8
2-Axis Combination	11
3-Axis Combination	13
4-Axis Combination	15
Example applications	16
Before you read this manual.....	17
Terms used in the manual.....	18
Selection of single axis specifications.....	19
Single Axis Specifications	21
Ball Screw Driven	22
Timing Belt Driven	36
R-Axis (Rotation)	50
Pushrod Type	52
Cartesian Axes Specifications	55
2-Axis Specifications X-Y Combination	56
X-Z Combination	77
Y-Z Combination	89
Z-Y Combination.....	102
3-Axis Specifications X-Y-Z Combination	113
4-Axis Specifications X-Y-Z-R Combination ..	134
Axis-Related Components	143
Axis Combination Bracket	144
Control System Parts	163
Controller Unit, Options	
Technical Notes	197
Actuator, Controller	
How to Calculate Tact (Cycle) Time	222

For Transfer of Light Loads ◆ Maximum payload 4kg  30kg

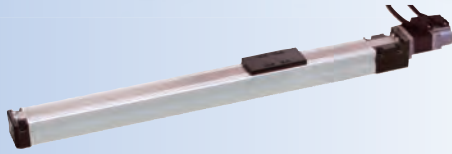

BA3-T5D (Ball screw drive)

- Motor output (W) 50
- Stroke (mm) 50 - 500
- Maximum payload (kg) (Note 1) 5 - 10 (horizontal), 1.5 - 3 (vertical)
- Maximum speed (mm/s) (Note 2) 800 (stroke 450mm max., lead 12mm)
- Positioning repeatability (mm) ±0.02

Available models: Pages 8-9 Description: Page 22

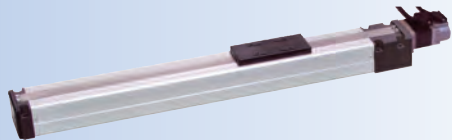

BA3-T7D (Ball screw drive)

- Motor output (W) 50
- Stroke (mm) 50 - 700
- Maximum payload (kg) (Note 1) 12 - 30 (horizontal), 4 - 8 (vertical)
- Maximum speed (mm/s) (Note 2) 800 (stroke 550mm max., lead 12mm)
- Positioning repeatability (mm) ±0.02

Available models: Pages 8-9 Description: Page 23



BA3-T3D (Ball screw drive) Pushrod type

- Motor output (W) 50
- Stroke (mm) 50 - 150
- Maximum payload (kg) 4 (horizontal), 1.9 (vertical)
- Maximum speed (mm/s) 600
- Positioning repeatability (mm) ±0.02

Available models: Pages 9-10 Description: Page 52

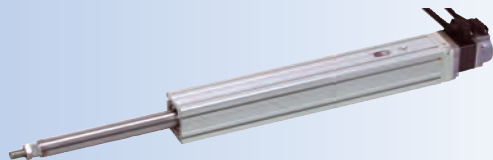

BA3-T4D (Ball screw drive) Pushrod type

- Motor output (W) 50
- Stroke (mm) 50 - 200
- Maximum payload (kg) 7 (horizontal), 3.1 (vertical)
- Maximum speed (mm/s) 600
- Positioning repeatability (mm) ±0.02

Available models: Pages 9-10 Description: Page 53

BA3-T5E (Ball screw drive) Pushrod type

- Motor output (W) 100
- Stroke (mm) 50 - 300
- Maximum payload (kg) 25 (horizontal), 6.5 (vertical)
- Maximum speed (mm/s) (Note 2) 600 (stroke 250mm max)
- Positioning repeatability (mm) ±0.02

Available models: Pages 9-10 Description: Page 54



BA3-00D (Harmonic drive)

- Motor output (W) 50
- Maximum payload (kg) 10
- Rotation range 360°
- Maximum speed (deg/s) 360
- Positioning repeatability (deg) ±0.025

Available models: Pages 10 Description: Page 50



BA3-00-RP (Planet gear)

- Motor output (W) 50
- Maximum payload (kg) 10
- Rotation range 360°
- Maximum speed (deg/s) 857
- Positioning repeatability (deg) ±0.125

Available models: Pages 10 Description: Page 51

Note 1: The payload varies depending on the lead and motor output.

Note 2: The speed varies depending on the lead and stroke.

For Transfer of Medium Loads ◆ Maximum payload 15kg 80kg



BA3-10 (Ball screw drive)

- Motor output (W) 100
- Stroke (mm) 100 - 1250
- Maximum payload (kg) (Note 1) 20 - 80 (horizontal), 3 - 22 (vertical)
- Maximum speed (mm/s) (Note 2) 1200 (stroke 600mm max., lead 20mm)
- Positioning repeatability (mm) ±0.01

Available models: Pages 8-9
Description: Page 24-25



BA3-30 (Ball screw drive)

- Motor output (W) 100, 200
- Stroke (mm) 100 - 1250
- Maximum payload (kg) (Note 1) 30 - 100 (horizontal), 3 - 40 (vertical)
- Maximum speed (mm/s) (Note 2) 1200 (stroke 600mm max., lead 20mm)
- Positioning repeatability (mm) ±0.01

Available models: Pages 8-9
Description: Page 26-29

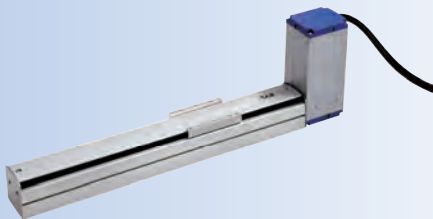

BA3-10 (Timing belt drive)

- Motor output (W) 100, 200
- Stroke (mm) 100 - 2550
- Maximum payload (kg) (Note 1) 15 - 20 (horizontal)
- Maximum speed (mm/s) (Note 2) 2000 (lead 42mm)
- Positioning repeatability (mm) ±0.04

Available models: Pages 8
Description: Page 36-39

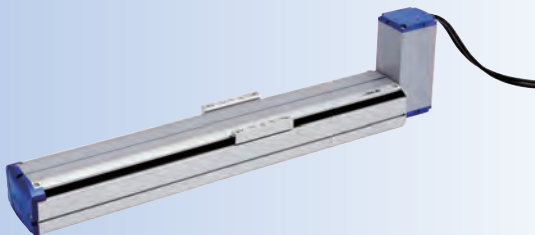

BA3-30 (Timing belt drive)

- Motor output (W) 100, 200
- Stroke (mm) 100 - 2550
- Maximum payload (kg) (Note 1) 15 - 20 (horizontal)
- Maximum speed (mm/s) (Note 2) 2000 (lead 42mm)
- Positioning repeatability (mm) ±0.04

Available models: Pages 8
Description: Page 40-43

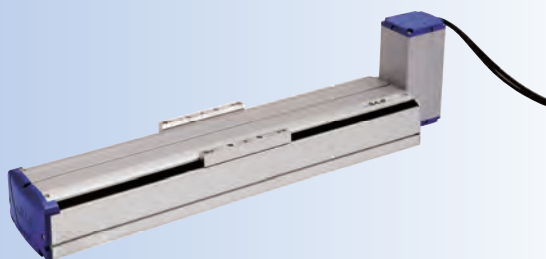

BA3-50 (Timing belt drive)

- Motor output (W) 200, 400
- Stroke (mm) 200 - 3500
- Maximum payload (kg) (Note 1) 20 - 40 (horizontal)
- Maximum speed (mm/s) (Note 2) 2000 (lead 42mm)
- Positioning repeatability (mm) ±0.04

Available models: Pages 8
Description: Page 44-47

Note 1: The payload varies depending on the lead and motor output.
Note 2: The speed varies depending on the lead and stroke.

For Transfer of Heavy Loads ♦ **Maximum payload 60kg** ||||||||| ▶ **250kg**



BA3-50 (Ball screw drive)

- Motor output (W) 200, 400
- Stroke (mm) 200 - 1600
- Maximum payload (kg) (Note 1) 60 - 150 (horizontal), 3 - 60 (vertical)
- Maximum speed (mm/s) (Note 2) .. 1200 (stroke 600mm max., lead 20mm)
- Positioning repeatability (mm) ±0.01

Available models: Pages 8-9 Description: Page 30-33

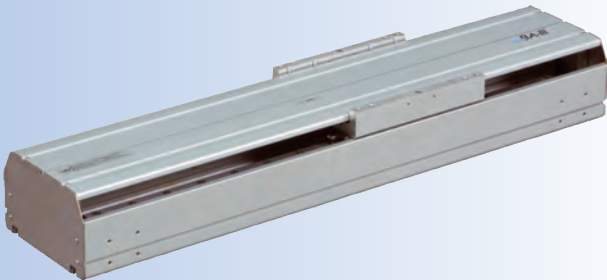

BA3-60 (Ball screw drive)

- Motor output (W) 400, 750
- Stroke (mm) 150 - 1700
- Maximum payload (kg) (Note 1) 25 - 250 (horizontal), 25 - 100 (vertical)
- Maximum speed (mm/s) (Note 2) .. 2400 (stroke 700mm max., lead 40mm 400W)
2300 (stroke 1000mm max., lead 40mm 750W)
- Positioning repeatability (mm) ±0.01

Available models: Pages 8-9 Description: Page 34-35

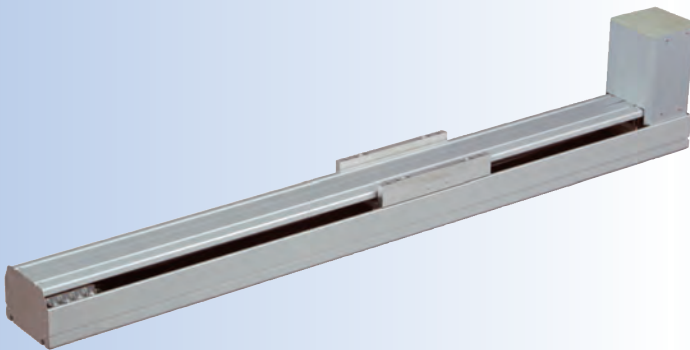

BA3-50 (Timing belt drive)

- Motor output (W) 400
- Stroke (mm) 150 - 4450
- Maximum payload (kg) 100 (horizontal)
- Maximum speed (mm/s) 1000
- Positioning repeatability (mm) ±0.05

Available models: Pages 8 Description: Page 48

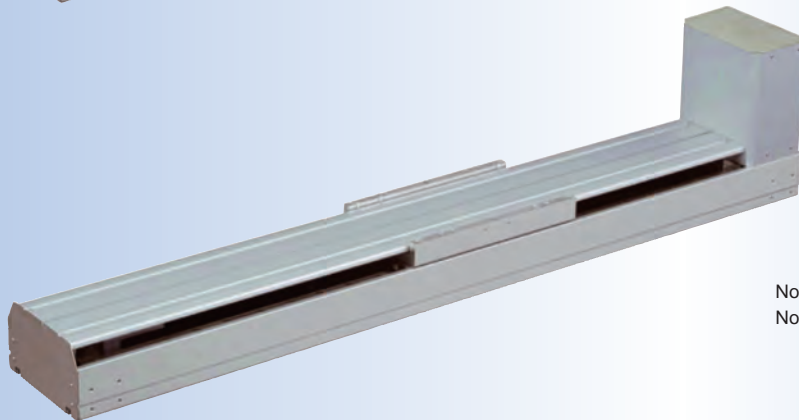

BA3-60 (Timing belt drive)

- Motor output (W) 750
- Stroke (mm) 150 - 4450
- Maximum payload (kg) 200 (horizontal)
- Maximum speed (mm/s) 1000
- Positioning repeatability (mm) ±0.05

Available models: Pages 8 Description: Page 49

Note 1: The payload varies depending on the lead and motor output.

Note 2: The speed varies depending on the lead and stroke.

[Cartesian axes] Typical Examples

Other combinations of multiple models are possible.

■ 2 axes (X-Y)

Type selection: Page 11
See Pages 56 - 76



■ 2 axes (X-Z)

Type selection: Page 11
See Pages 77 - 88



■ 2 axes (Y-Z)

Type selection: Page 12
See Pages 89 - 101



■ 2 axes (Z-Y)

Type selection: Page 12
See Pages 102 - 112



■ 3 axes (X-Y-Z)

Type selection: Page 13 - 14
See Pages 113 - 133

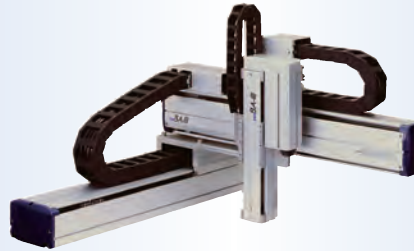

■ 4 axes (X-Y-Z-R)

Type selection: Page 15
See Pages 134 - 141

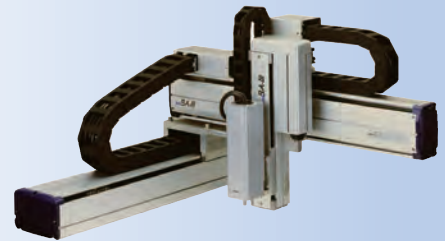

[Components of control system] Controller

Master unit

See Pages 164 - 170



CA25-M10



CA25-M40
CA25-M80

Slave unit

See Pages 171 - 175



CA25-S10



CA25-S40
CA25-S80

[Components of control system] Controller

Other optional units



With extension I/O Unit
See Pages 178 - 179



With CC-Link Unit
See Pages 180 - 182



With DeviceNet Unit
See Pages 183 - 185

Regenerative discharge unit

See Pages 186 - 190



ABSU-2000
ABSU-4000*

* ABSU-4000 is attached to the fan bottom.



ABSU-8000

Teach pendant

See page 191



TPH-4C

Type Selection

Single Axis Specifications

Single axis payload table (horizontal)8

Single axis payload table (vertical, rotation)9

2-Axis Combination

2-axis (X-Y) combination payload table11

2-axis (X-Z) combination payload table11

2-axis (Y-Z) combination payload table12

2-axis (Z-Y) combination payload table12

3-Axis Combination

3-axis (X-Y-Z) combination payload table13

4-Axis Combination

4-axis (X-Y-Z-R) combination payload table15

Single axis payload table (horizontal)

Ball screw driven

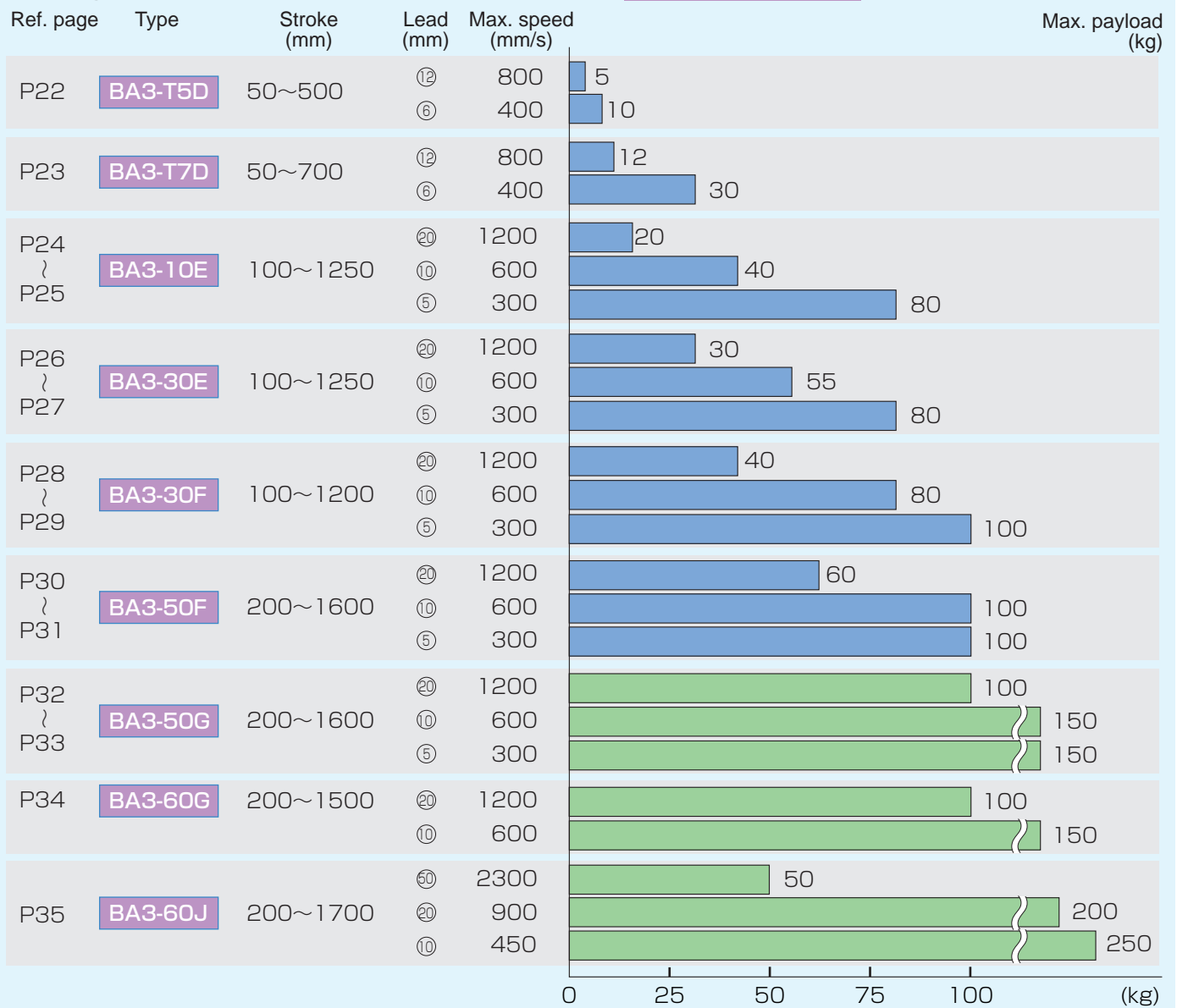

Single axis payload table (horizontal)

Timing belt driven

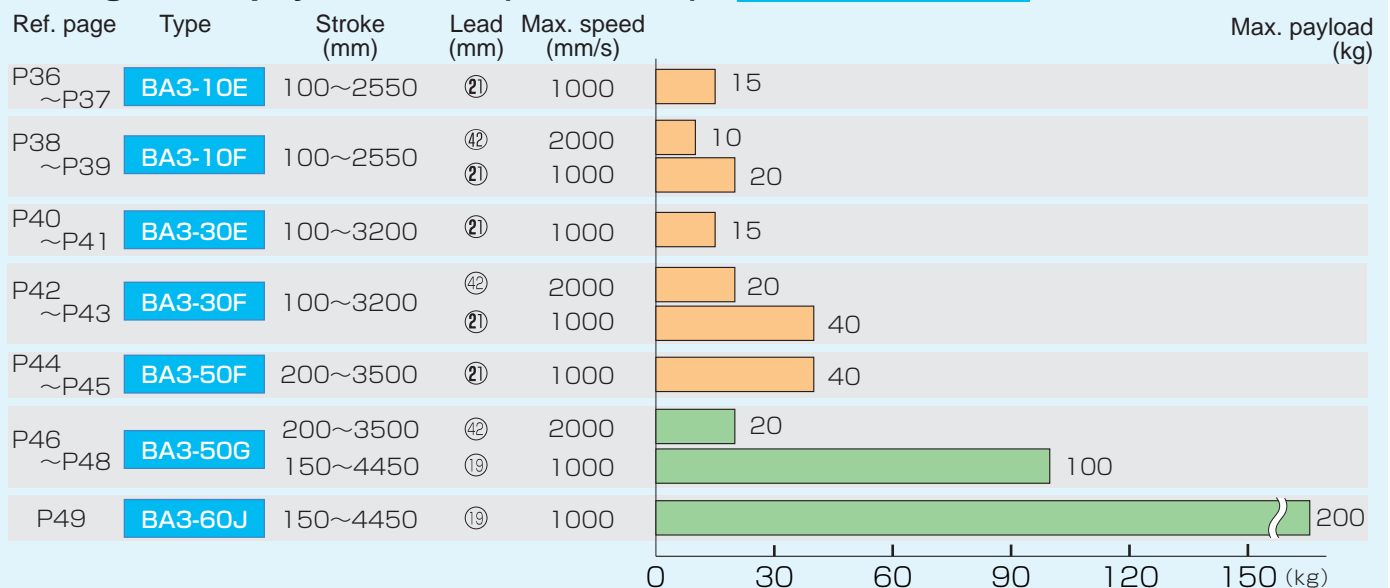

* When a regenerative discharge unit is used.

Single axis payload table (horizontal) Ball screw driven (pushrod type)

Ref. page	Type	Stroke (mm)	Lead (mm)	Max. speed (mm/s)	Max. payload (kg)
P52	BA3-T3D	50~150	⑫	600	4
P53	BA3-T4D	50~200	⑫	600	7
P54	BA3-T5E	50~300	⑫	600	25

Single axis payload table (vertical) Ball screw driven

Ref. page	Type	Stroke (mm)	Lead (mm)	Max. speed (mm/s)	Max. payload (kg)
P22	BA3-T5D	50~500	⑫	800	1.5
			⑥	400	3
P23	BA3-T7D	50~700	⑫	800	4
			⑥	400	8
P24 } P25	BA3-10E	100~1250	⑳	1200	3 5
			⑩	600	8 12
			⑤	300	15 22
P26 } P27	BA3-30E	100~1250	⑳	1200	3 5
			⑩	600	8 12
			⑤	300	15 22
P28 } P29	BA3-30F	100~1200	⑳	1200	3 10
			⑩	600	8 20
			⑤	300	15 40
P30 } P31	BA3-50F	200~1600	⑳	1200	3
			⑩	600	8 20
			⑤	300	15 40
P32 } P33	BA3-50G	200~1600	⑳	1200	25
			⑩	600	50
			⑤	300	60
P34	BA3-60G	200~1500	⑳	1200	25
			⑩	600	50
P35	BA3-60J	200~1700	⑤⑩	2300	—
			⑳	900	50
			⑩	450	100

 * When a regenerative discharge unit is used.

Single axis payload table (vertical) Ball screw driven (pushrod type)

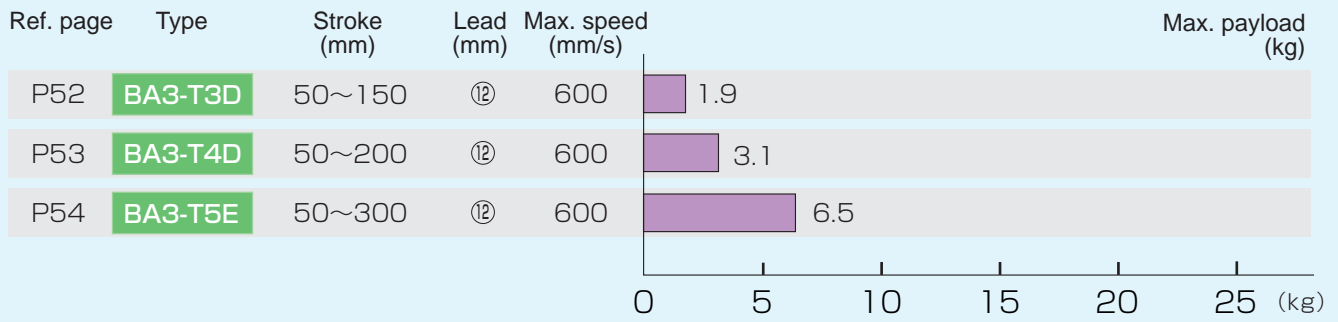

Single axis payload table (rotation) Harmonic drive Planet gear

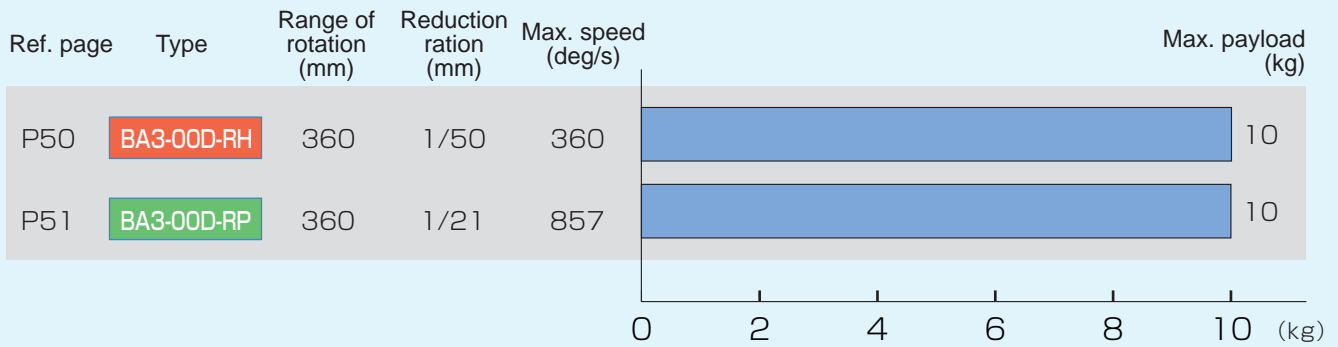

2-axis (X-Y) Combination payload table

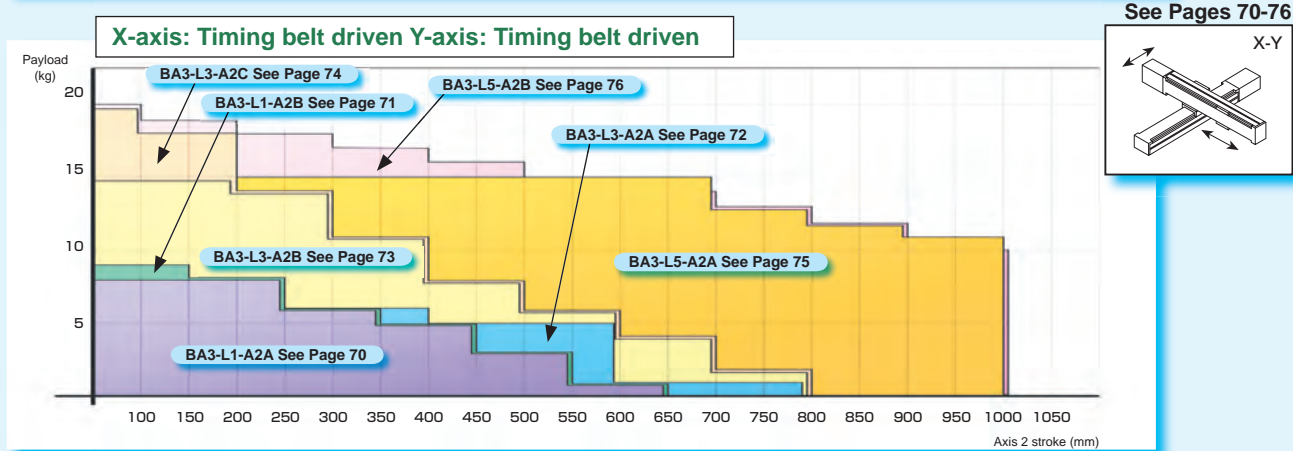
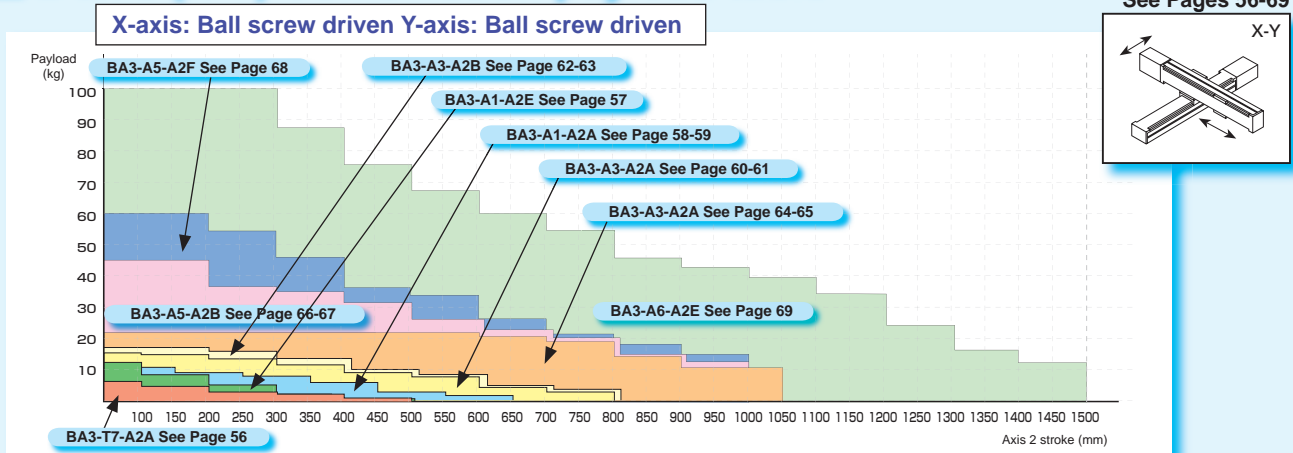

2-axis (X-Z) Combination payload table

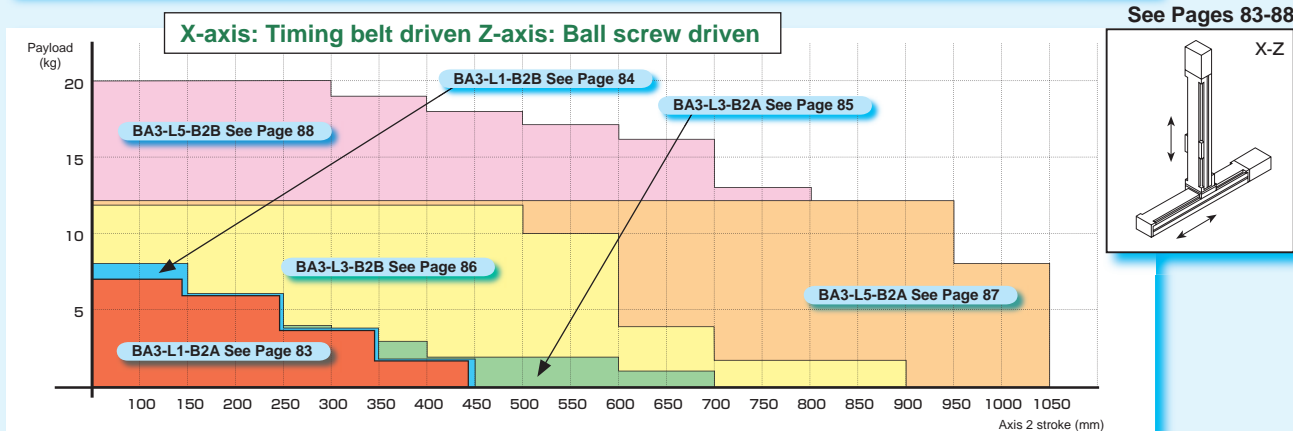
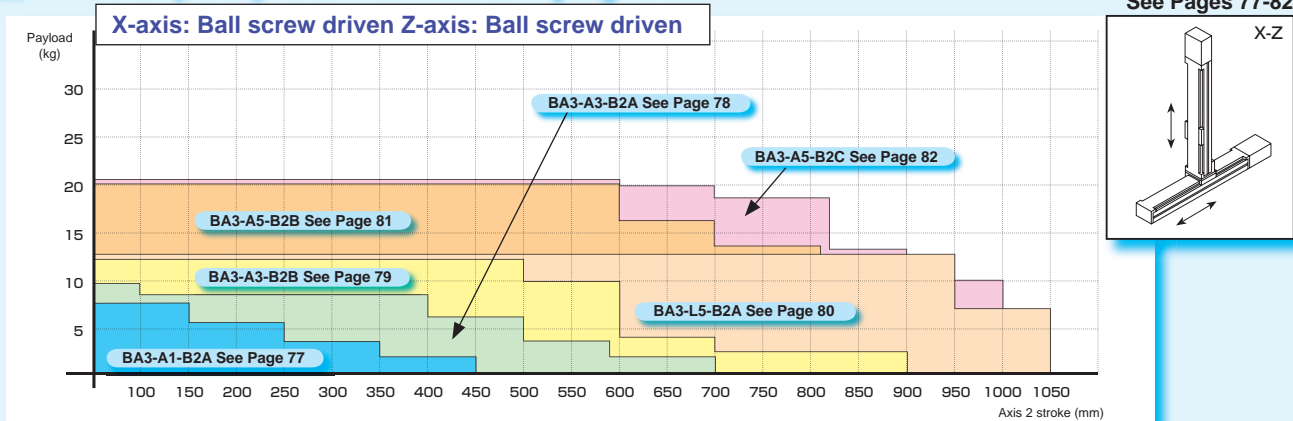

2-axis (Y-Z) Combination payload table

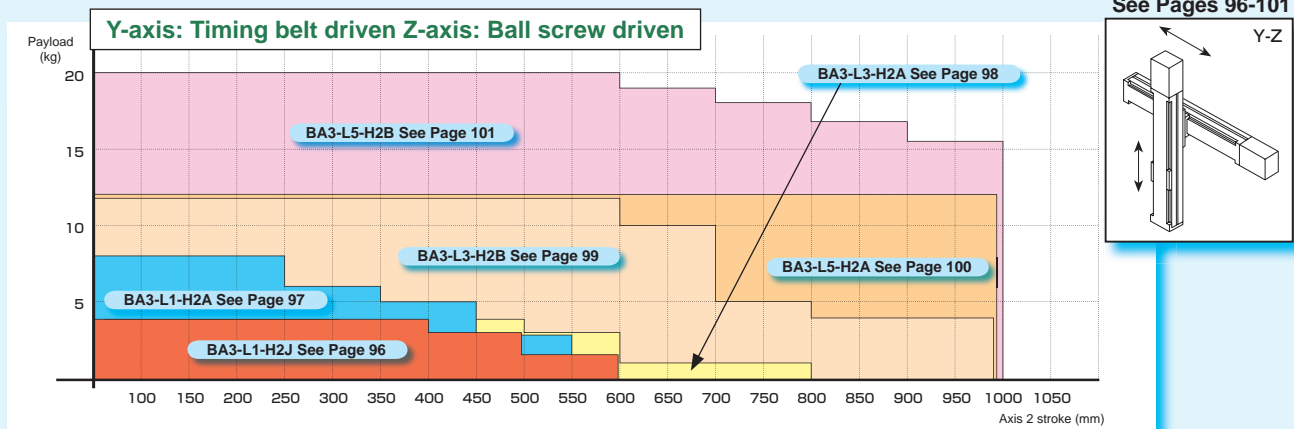
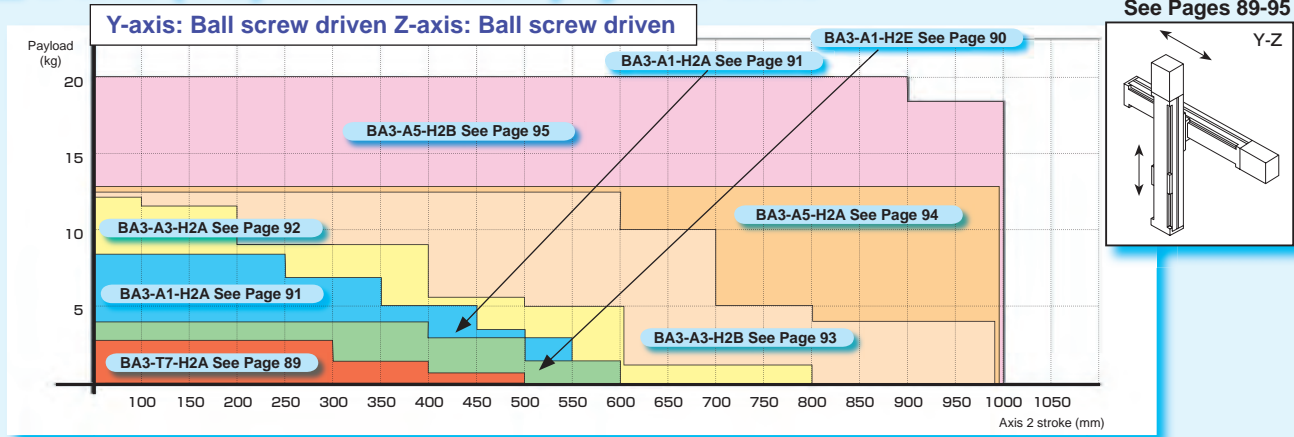

2-axis (Z-Y) Combination payload table

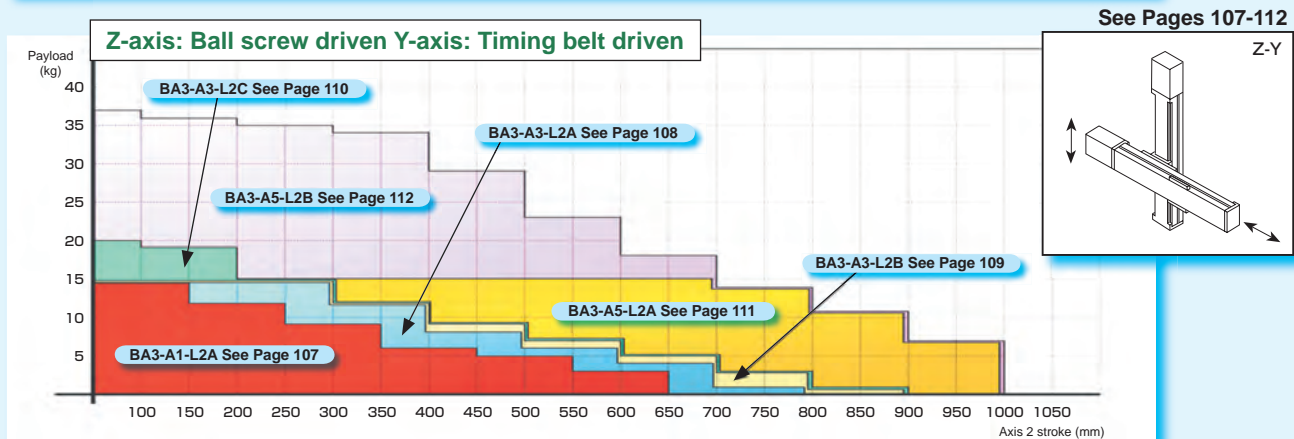
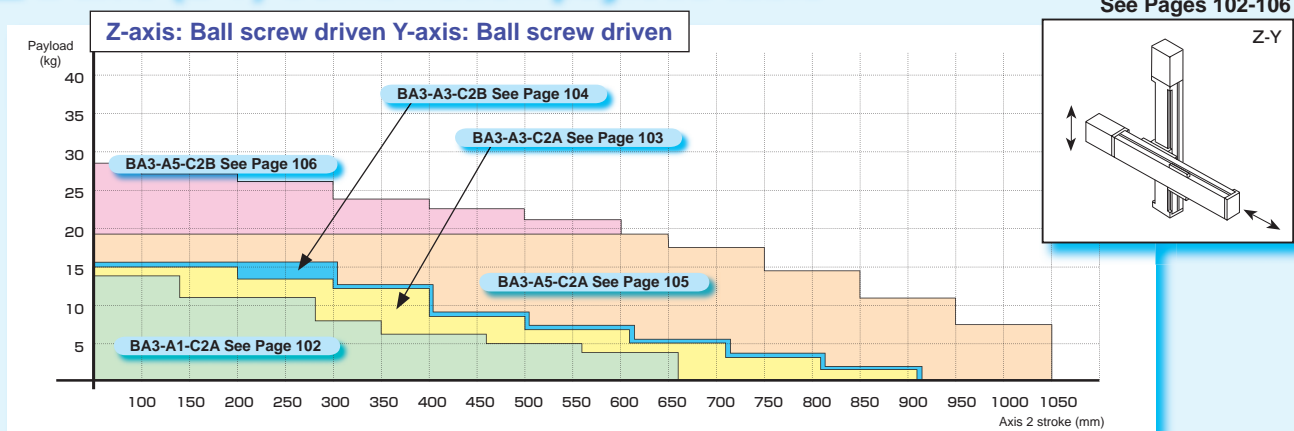

3-axis (X-Y-Z) Combination payload table

X-axis: Ball screw driven Y-axis: Ball screw driven Z-axis: Ball screw driven

See Pages 113-128

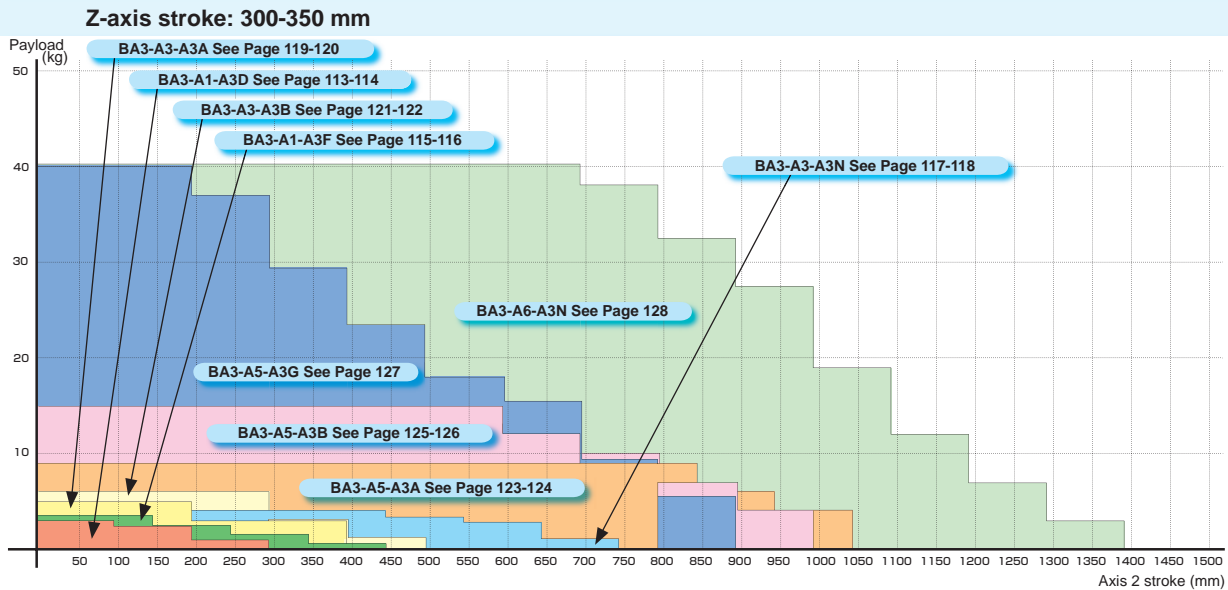
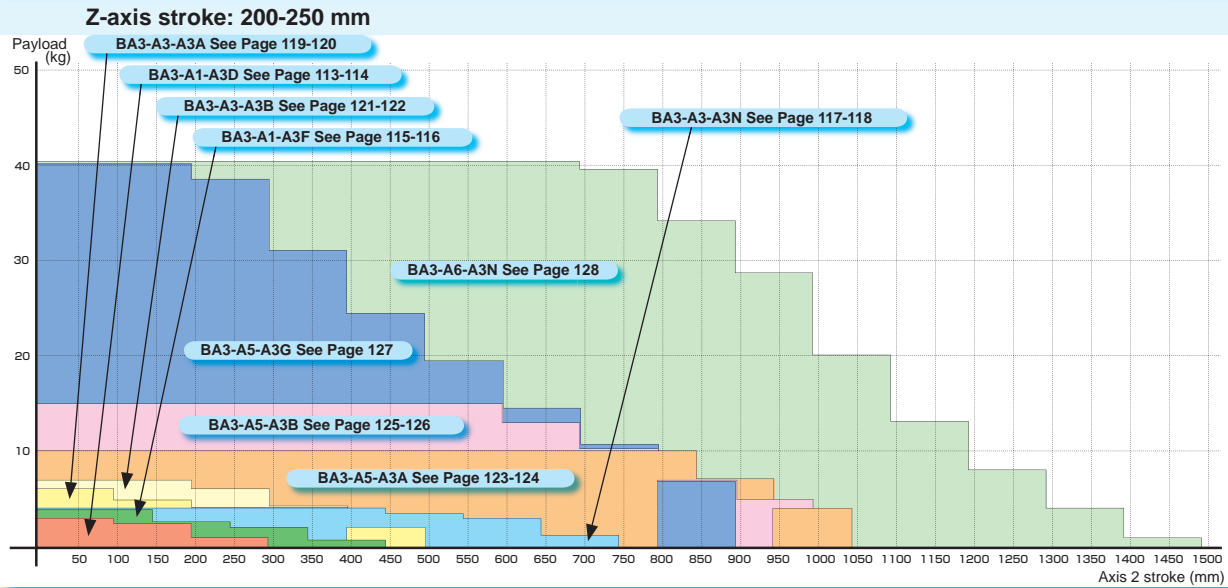
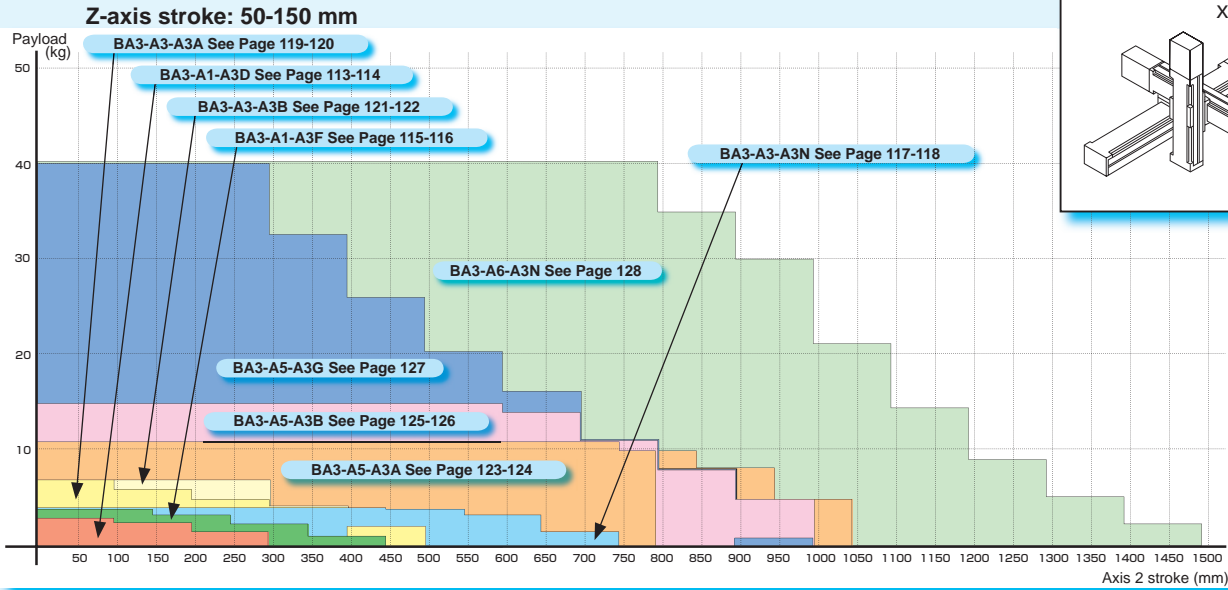
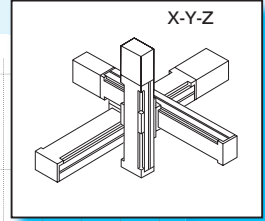

3-axis (X-Y-Z) Combination payload table

X-axis: Timing belt driven Y-axis: Timing belt driven Z-axis: Ball screw driven

See Pages 129-133

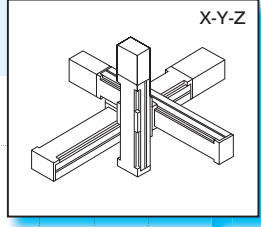

Z-axis stroke: 50-150 mm

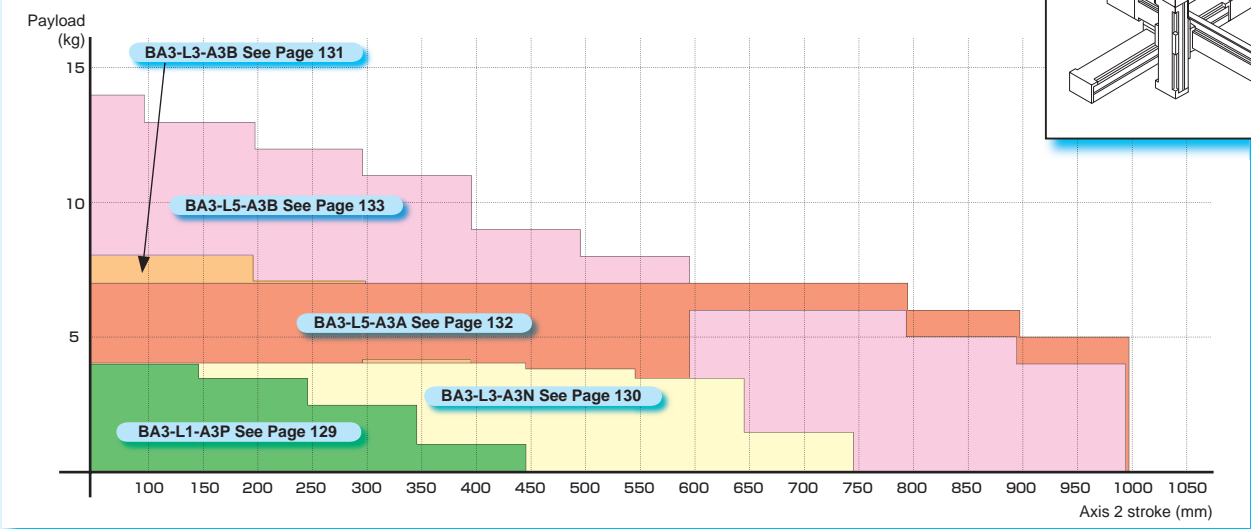

Z-axis stroke: 200-250 mm

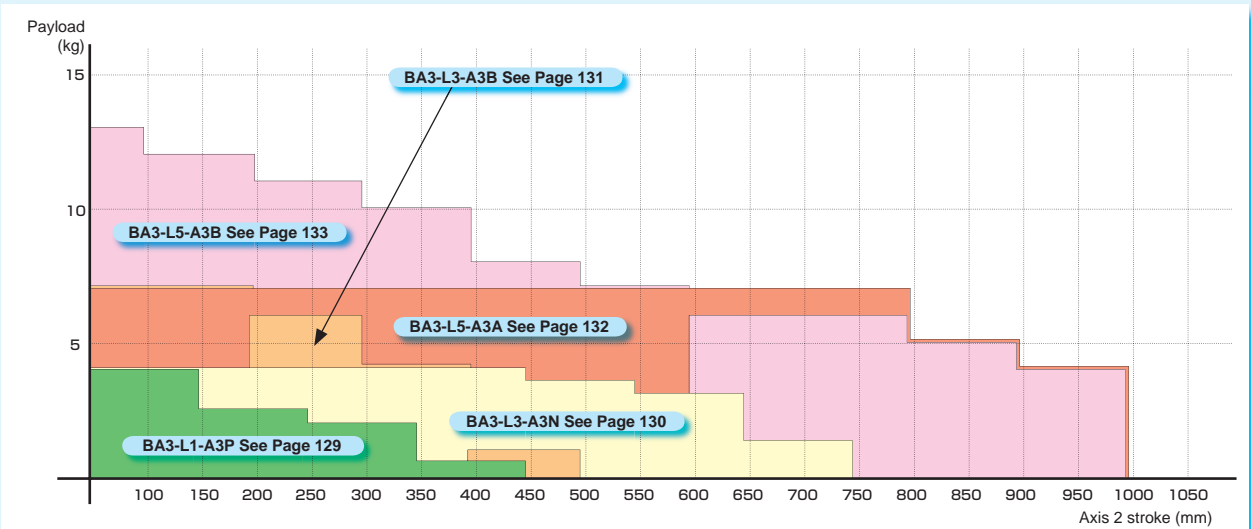

Z-axis stroke: 300-350 mm

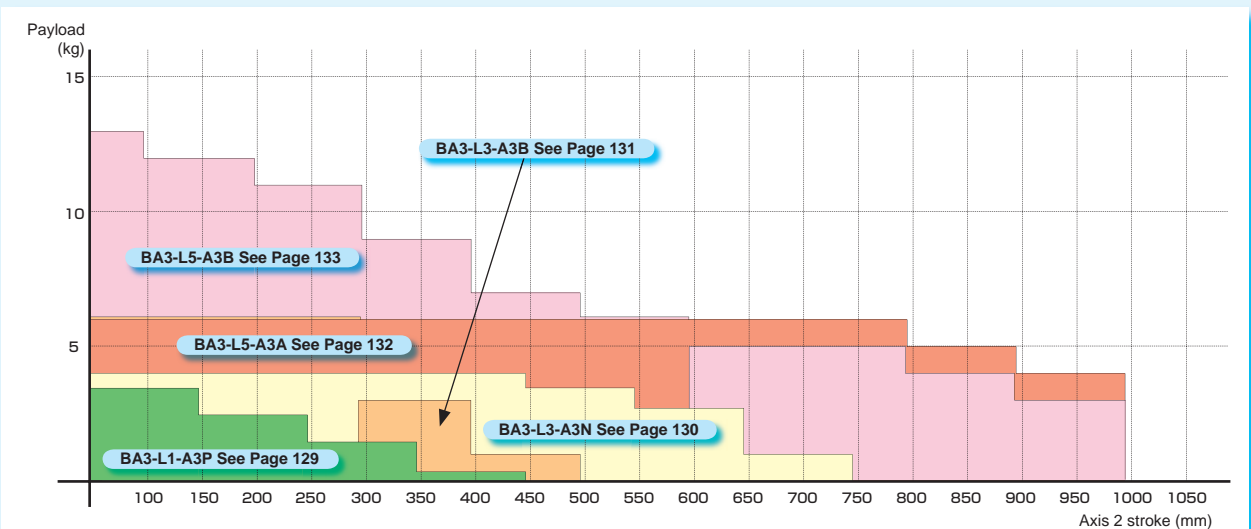

4-axis (X-Y-Z-R) Combination payload table

X-axis: Ball screw driven Y-axis: Ball screw driven Z-axis: Ball screw driven R-axis: Rotating axis

See Pages 134-141

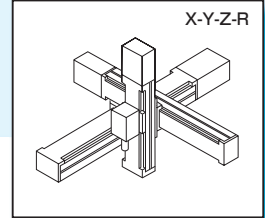

Z-axis stroke:100 mm

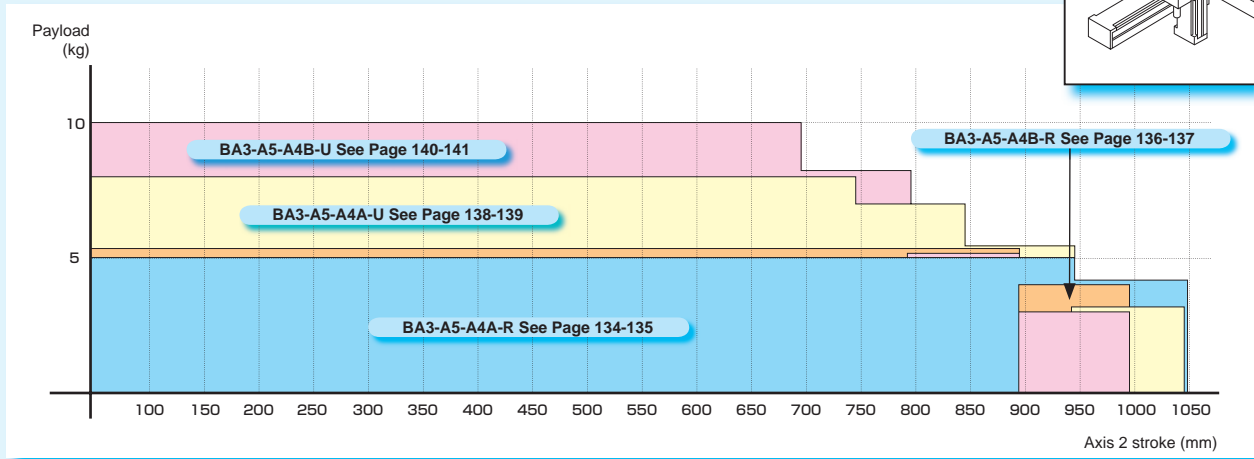

Z-axis stroke:200 mm

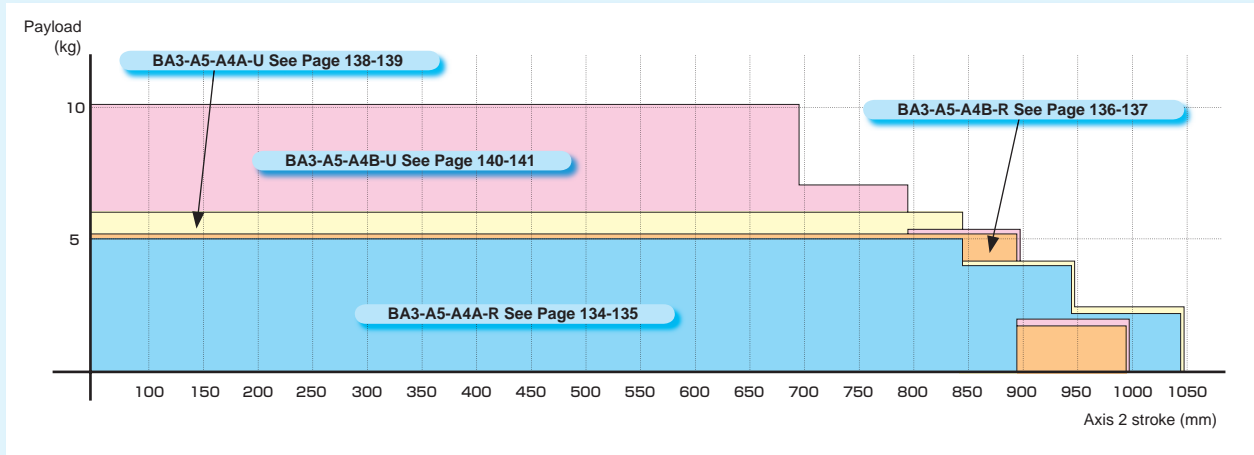

Z-axis stroke:300 mm

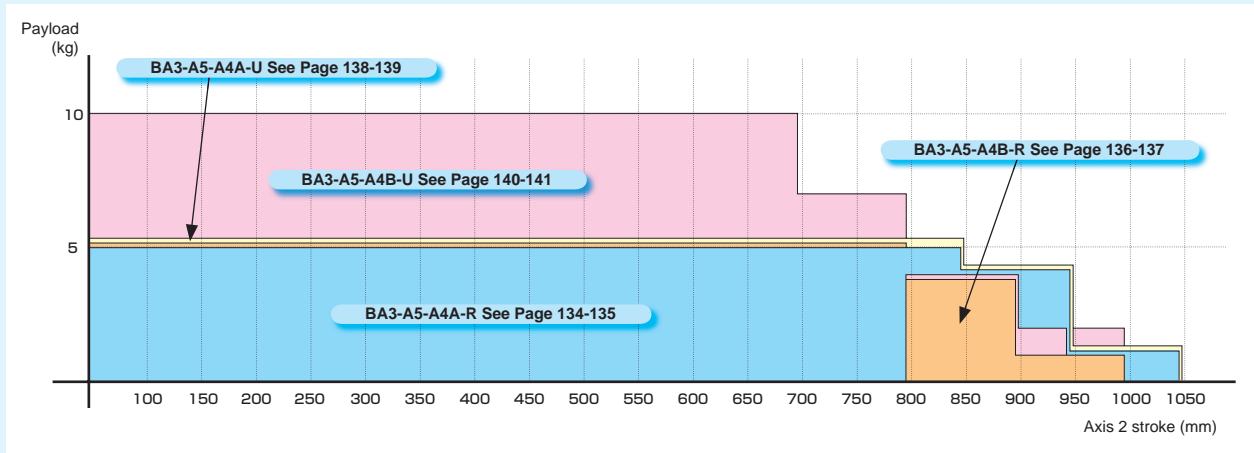

■ Example applications

Transfer

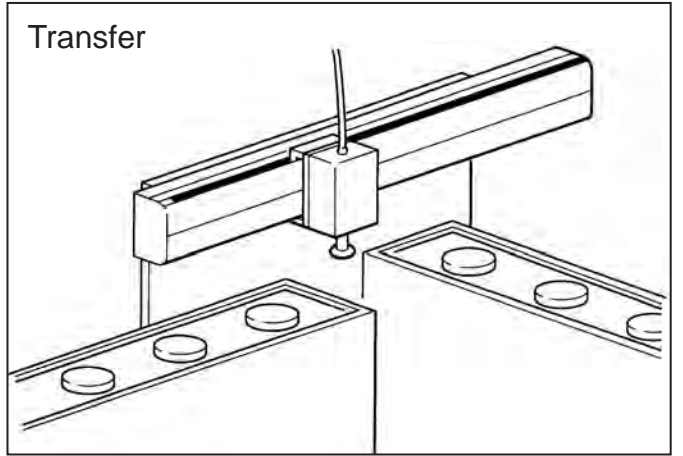

Loading parts

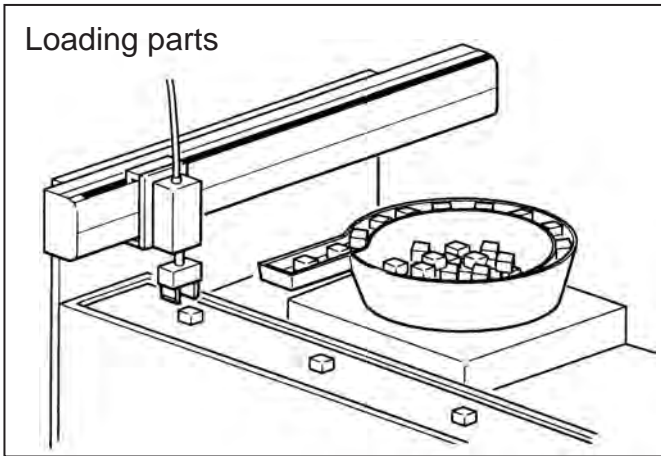

Inspection

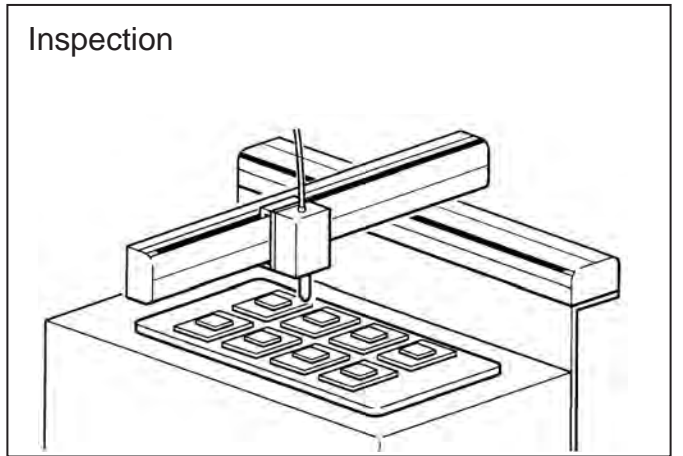

Palletizing

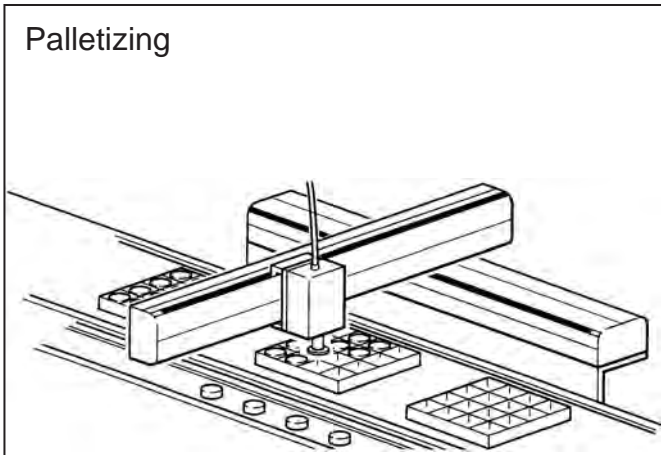

Parts assembly

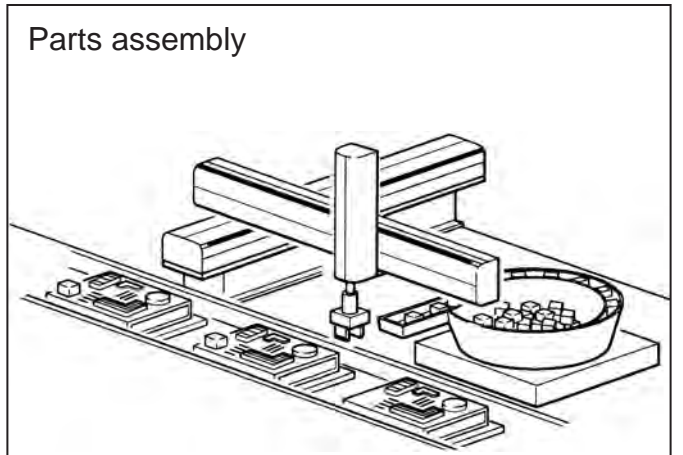

Sealing

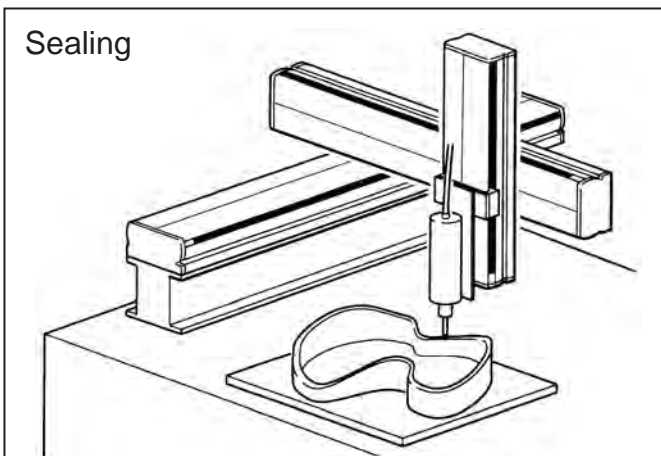

Cutting

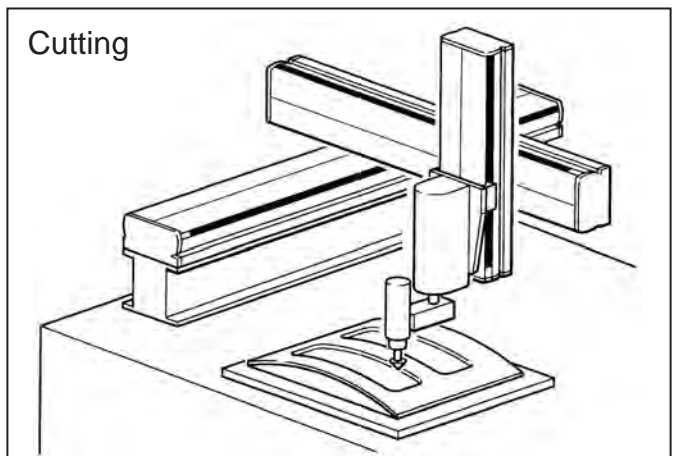

Before you read this manual

■ Definition of terms ■

[Axis1 and Axis2]: When forming a Cartesian axes configuration, an axis which is mounted directly on the user-provided equipment is called the “Axis 1”, and the other axis which is mounted on the Axis 1 with a bracket is called the “Axis 2”.

[Straight axis]: An axis whose ball screw and servo motor shaft centers are placed along a straight line.

[Right side mounted axis, Left side mounted axis and Bottom side mounted axis]: An axis whose servo motor is turned back, which is coupled with a ball screw via a timing belt. When the motor is located on the right side when seen from the end block side of the actuator with the slider of the actuator facing up, this axis is called the “right side mounted motor axis.” Likewise, when it is located on the left side and bottom side, the axis is called the “left side mounted motor axis” and “bottom side mounted motor axis”, respectively.

[Long slider type]: Used for the moving-axis (BB30, BB50) or for an axis on which large load moment is exerted.

[Medium slider type]: Used for the axis 1 of a Cartesian axes configuration or as the standard axis of a single axis configuration.

[Short slider type]: Used for a single axis with relatively small load moment or for the axis 2 and axis 3 of a Cartesian axes configuration.

[Work area]: The location of the work area is defined by the side (right or left) when viewed from the end block side of the axis 1 in a Cartesian axes configuration.

[Axis 2 slider motor side]: When the Axis 2 slider is seen from the end block side of the Axis 1 in a Cartesian axes configuration, it is located on the rear side of the axis. (When the slider is located on the front side (standard), it is called the “slider end side”.

[Moving-axis type]: Generally, the frame of the actuator (axis) is secured and the slider moves. For the moving-axis type, the slider is secured and the frame of the actuator moves. A hand or other tooling is attached to the end block at the end of the frame.

[Table type]: In a single or a Cartesian axes configuration, the slider surface is horizontal and faces up to allow the work from the upper side.

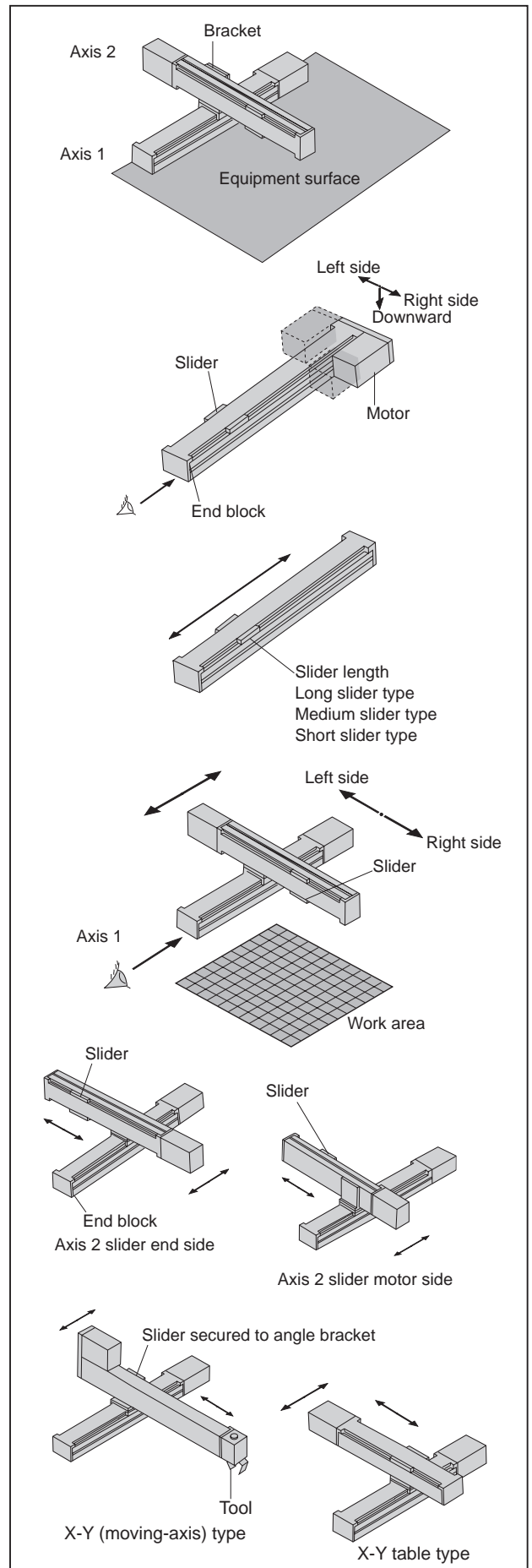

Terms used in the manual

Terms used throughout this publication are classified into the two groups; general robot terms and those specific to Toshiba Machine robots.

Terms used for actuator (or axis)

[Slider]

The part of the actuator which moves along a straight line. A hand or other tooling is assembled to the slider.

When a bracket for axis combination is mounted on the slider, a two axes system can be configured.

This is also called the "saddle" in overseas nations.

[Drive system]

Components for power transformation, such as the ball screw and timing belt, which are used to drive the movable part of the actuator.

[Maximum speed]

Maximum speed (mm/s) which the actuator can attain under specified conditions (payload, for instance).

[Maximum payload]

Maximum Payload (kg) under specified conditions (acceleration/ deceleration time, speed, rigidity, service life, etc.).

[Allowable load moment]

Allowable force (moment) in N·m (kg·m) which acts on the movable part (slide) of the actuator. It comes in two types; static and dynamic.

[Positioning repeatability]

Repeatability of positioning operations obtained under the same conditions using the same method. The difference between the maximum and minimum values of the result is figured out, then "±" sign is attached to half the difference.

[Resolution]

Minimum travel distance of an axis, which can be set during robot teaching.

[Acceleration/deceleration time (ta)]

The time (seconds) spent until the movable part of the actuator accelerates and reaches its set speed, or the time (seconds) spent until it slows down from its set speed and stops.

This factor is used as a condition for determining the maximum Payload and tact (or cycle) time.

Normally, this value can be specified in a program.

[Lead]

Lead is the distance advanced by one turn of the ball screw. For the belt type, this is expressed as the ball screw equivalent lead.

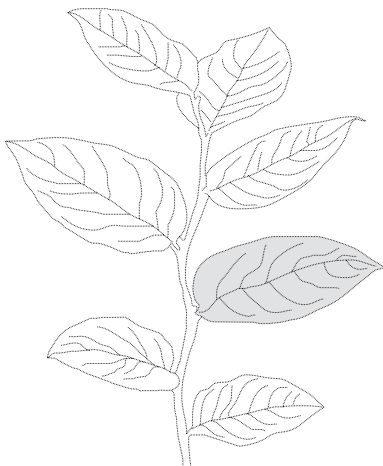

Terms used for controller

[Sequential mode]

A mode in which program steps are executed one by one in order.

[Palletizing mode]

A mode in which traveling and loading operations (i.e., palletizing operation) can be executed easily by specifying points to move, the number of points, etc.

The following motions are available.

- From a given point to another point on a matrix (1 to M)
- From a point on a matrix to a given point (M to 1)
- From a point on a matrix to another point on another matrix (M to M)

[External point designation mode]

A mode in which only positioning motions are executed by specifying a PLC (i.e., sequencer) connected to inputs and digital switches, without using normal controller instruction words. Coordinates, speed and acceleration of specified points should be set in the table registered in the controller beforehand.

[Continuous mode]

A mode in which each step of a program is executed sequentially in either of sequential, easy and palletizing modes every time the START pushbutton switch on the teach pendant is pressed. (Normally used mode)

[Step mode]

A mode in which each single step of a program is executed and stopped in either sequential, easy or palletizing modes every time the START pushbutton switch on the teach pendant is pressed. (Program check mode)

[Manual mode]

A mode in which a program is executed and stopped after the axis feed or input/output command is executed in either sequential, easy or palletizing modes every time the START pushbutton switch on the teach pendant is pressed or the start input is given. (Test run mode, check mode before day's operation)

[Remote teaching]

A method of teaching the robot to move to a desired position by pressing move keys on the teach pendant (remote operation) in the servo ON condition.

[Direct teaching]

A method of directly teaching the robot arm by operator's hand to a desired position and of teaching the robot such a position in the servo OFF condition.

[MDI (Manual data input)]

A method of directly entering desired coordinates through the keyboard (numerical input) according to the display shown on the teach pendant.

Notes on selecting and operating Cartesian robots

- The position accuracy uses the position repeat accuracy as the specification value.

The position repeat accuracy is the value for single-direction positioning at a fixed ambient temperature and fixed robot temperature.

Note that errors occur in the position repeat accuracy and absolute position accuracy using \pm bidirectional positioning.

- The position repeat accuracy is the specification value for a single axis. For the position repeat accuracy of combination specifications, the position repeat accuracy of each single axis is the specification value.

Selection of single axis specifications

The set designation is shown below. Also refer to Pages 20 to 47.

This page can be used as an order sheet. Enter each quantity, including options.

Set designation	BA3 - <input type="text"/> <input type="text"/> <input type="text"/> - <input type="text"/> <input type="text"/> - <input type="text"/> <input type="text"/> <input type="text"/> <input type="text"/> - <input type="text"/> <input type="text"/> - <input type="text"/> <input type="text"/>	Q'ty
	① ② ③ ④ ⑤ ⑥ ⑦ ⑧ ⑨	

① Type of axis

10 : BE10
30 : BE30
50 : BE50
60 : BE60
T3 : BET3
T4 : BET4
T5 : BET5
T7 : BET7
00 : R-axis

② Type of motor

D : 50W absolute
E : 100W absolute
F : 200W absolute
G : 400W absolute
J : 750W absolute

③ Axis structure

Ball screw driven	Timing belt driven	R-axis
ST : Straight axis	BT : Motor facing up	RH : Harmonic drive
UR : Right side mounted motor axis	BU : Motor facing down	RP : Planet gear
UL : Left side mounted motor axis	BR : Motor facing right	
UU : Bottom side mounted motor axis	BL : Motor facing left	
LT : Nut rotation drive with flexible duct left mounted		
RT : Nut rotation drive with flexible duct right mounted		

④ Type of slider

S : Short slider
M : Medium slider
L : Long slider
A : L type bracket (R-axis)
F : Flange type (R-axis)
C : Pushrod type

⑤ Lead

Ball screw driven	Timing belt driven
05 : 5 mm	19 : 19.555 mm
06 : 6 mm	21 : 21 mm
10 : 10 mm	42 : 42 mm
12 : 12 mm	R-axis
20 : 20 mm	00 : Fixation
40 : 40 mm	

⑥ Brake

N : Without brake
B : With brake

⑦ Stroke

05 : 50 mm ~ **95** : 950 mm
A0 : 1000 mm ~ **H5** : 1750 mm
J0 : 1800 mm ~ **N5** : 2250 mm
P0 : 2300 mm ~ **V5** : 2950 mm
W00 : 3000 mm ~ **W95** : 3950mm
X00 : 4000 mm ~ **X95** : 4950mm
36 : 360 deg. (R-axis)

⑧ CA25-M*0 (Master unit)

0 : Without controller
1 : Input/output NPN specifications
General-purpose I/O (Inputs: 4, Outputs: 4)
2 : NPN with extension input/output unit specifications
General-purpose I/O (Inputs: 28, Outputs: 12)
3 : NPN with CC-Link unit specifications
4 : NPN with DeviceNet unit specifications
5 : Input/output PNP specifications
General-purpose I/O (Inputs: 4, Outputs: 4)
6 : PNP with extension input/output unit specifications
General-purpose I/O (Inputs: 28, Outputs: 12)
7 : PNP with CC-Link unit specifications
8 : PNP with DeviceNet unit specifications

⑨ Cable length (between axis (actuator) and controller)

3 : 3 m
5 : 5 m
7 : 7 m
9 : 9 m
B : 11 m
D : 13 m

Options

Designation	Type	Remarks	Q'ty
I/O cable	CA10-IC-A <input type="checkbox"/> 0	For master unit, slave unit, and extension I/O unit Cable length 3: 3 m, 5: 5 m	
Regenerative discharge unit	ABSU-2000	Servomotor capacity (for 50 W, 100 W, 200 W)	
	ABSU-4000	Servomotor capacity (for 400 W)	
	ABSU-8000	Servomotor capacity (for 750 W)	
Home position change sensor	HBS-BA10	For ball screw driven axis	
	HBS-BA20	For timing belt driven axis	
	HBS-BA20L		
Teach pendant *1	TPH-4C	For programming and parameter setting	
Software for personal computer *2	SF-98D	Tool for creating programs and data maintenance	
Communication cable	PCBL-31	RS-232C communication cable between PC and controller	
Link cable	CA10-LC-A <input type="checkbox"/>	Cable length 01: 150 mm, 03: 300 mm, 10: 1000 mm	

*1) Version 2.26 or higher is supported in the CA25 series.

*2) Version 3.1.0 or higher is supported in the CA25 series.

Selection of cartesian axes specifications

The set designation is shown below. Also refer to Pages 56 to 141.

This page can be used as an order sheet. Enter each quantity, including options.

Set designation	BA3 - <input type="text"/> <input type="text"/> - <input type="text"/> <input type="text"/> <input type="text"/> <input type="text"/> - <input type="text"/> <input type="text"/> <input type="text"/> <input type="text"/> <input type="text"/> <input type="text"/> <input type="text"/> <input type="text"/> <input type="text"/> <input type="text"/>	Q'ty
	① ② ③ ④ ⑤ ⑥ ⑦ ⑧ ⑨ ⑩ ⑪	

Type of combined axes structure: Select the combined axes structure (motor direction).
 Type of combined axes: Select the type of the Axis 2 and on.

See Pages 56 to 141

① Main load axis

Ball screw driven	Timing belt driven
T7 : BET7	L1 : BE10
A1 : BE10	L3 : BE30
A3 : BE30	L5 : BE50
A5 : BE50	
A6 : BE60	

② Combined axes structure

A : X-Y, X-Y-Z, X-Y-Z-R
B : X-Z
C : Z-Y (All axes are driven by ball screws.)
H : Y-Z
L : Z-Y (Z-axis is driven by ball screw and Y-axis by timing belt.)

③ No. of axes

2 : 2 axis
3 : 3 axis
4 : 4 axis

④ Type of slider

■ : Motor

R: Right-handed, 2 slider end side

L: Left-handed, 2 slider end side

S: Right-handed, 2 slider motor side

M: Left-handed, 2 slider motor side

⑤ Axis 1 stroke **⑥ Axis 2 stroke** **⑦ Axis 3 stroke**

05 : 50 mm ~ **95** : 950 mm
A0 : 1000 mm ~ **H5** : 1750 mm
J0 : 1800 mm ~ **N5** : 2250 mm
P0 : 2300 mm ~ **V5** : 2950 mm
W00 : 3000 mm ~ **W95** : 3950 mm
X00 : 4000 mm ~ **X95** : 4950 mm
 36 : 360 deg. (R-axis)

⑧ R-axis (axis 4)

0 : None
R : Harmonic drive
U : Planet gear

⑩ CA25-M*0 (Master unit)

0 : Without controller
1 : Input/output NPN specifications
 General-purpose I/O (Inputs: 4, Outputs: 4)
2 : NPN with extension input/output unit specifications
 General-purpose I/O (Inputs: 28, Outputs: 12)
3 : NPN with CC-Link unit specifications
4 : NPN with DeviceNet unit specifications
5 : Input/output PNP specifications
 General-purpose I/O (Inputs: 4, Outputs: 4)
6 : PNP with extension input/output unit specifications
 General-purpose I/O (Inputs: 28, Outputs: 12)
7 : PNP with CC-Link unit specifications
8 : PNP with DeviceNet unit specifications

⑪ Cable length (between axis (actuator) and controller)

3 : 3 m **9** : 9 m
5 : 5 m **B** : 11 m
7 : 7 m **D** : 13 m

Note: The unit cannot be installed by the customer.

Options

Designation	Type	Remarks	Q'ty
I/O cable	CA10-IC-A <input type="checkbox"/> 0	For master unit, slave unit, and extension I/O unit Cable length 3: 3 m, 5: 5 m	
Regenerative discharge unit	ABSU-2000	Servomotor capacity (for 50 W, 100 W, 200 W)	
	ABSU-4000	Servomotor capacity (for 400 W)	
	ABSU-8000	Servomotor capacity (for 750 W)	
Home position change sensor	HBS-BA10	For ball screw driven axis	
	HBS-BA20	For timing belt driven axis	
	HBS-BA20L		
Teach pendant *1	TPH-4C	For programming and parameter setting	
Software for personal computer *2	SF-98D	Tool for creating programs and data maintenance	
Communication cable	PCBL-31	RS-232C communication cable between PC and controller	
Link cable	CA10-LC-A <input type="checkbox"/>	Cable length 01: 150 mm, 03: 300 mm, 10: 1000 mm	

*1) Version 2.26 or higher is supported in the CA25 series.
 *2) Version 3.1.0 or higher is supported in the CA25 series.

Single Axis Specifications

Ball Screw Driven

BA3-T5.....	22
BA3-T7	23
BA3-10.....	24
BA3-30.....	26
BA3-50.....	30
BA3-60.....	34

Timing Belt Driven

BA3-10.....	36
BA3-30.....	40
BA3-50.....	44
BA3-60.....	49

R-Axis

BA3-00D-RH.....	50
BA3-00D-RP	51

Pushrod

BA3-T3.....	52
BA3-T4.....	53
BA3-T5.....	54

[Set designation]

BA3 – T5D – ST – M 12 N – 40 – 1 3

Type of slider M : Medium slider	Lead 06 : 6mm 12 : 12mm	Brake N : Without brake B : With brake	Stroke Type designation	Controller (CA25-M10) 0 : None 1 : NPN output specifications Other : See page 19	Cable length 3 : 3m 9 : 9m 5 : 5m B : 11m 7 : 7m D : 13m
-------------------------------------	-------------------------------	--	----------------------------	---	---

[Specifications]

Motor	50 W AC servo motor (absolute)		
Drive system	Precisely rolled ball screw, thread outer diameter 8 mm		
Stroke (mm) (in increments of 50 mm)	Medium slider	50 ~ 450	500
	Type designation	05 ~ 45	50
Maximum speed (mm/s)	Lead 12 mm	800	680
	Lead 6 mm	400	340
Maximum payload (kg) Acceleration/deceleration time: 0.3 sec or over	Lead 12 mm	Horizontal transfer: 5 Vertical transfer: 1.5	
	Lead 6 mm	Horizontal transfer: 10 Vertical transfer: 3	
Positioning repeatability (mm)	± 0.02		
Resolution (mm)	0.01		
Allowable static load moment (N·m)	Medium slider MR : 31 MP : 12 MY : 12		
Brake	Brake voltage DC24 V		
Master controller	CA25-M10		

- Notes:
- * When using the axis as a vertical axis, select the type with brake.
 - * The maximum payload signifies a load exerted on top of the slider. Also refers to the description on the dynamic load moment appearing later in this document.
 - * The acceleration/deceleration time represents the time until the axis reaches a programmed speed.

[Axis designation]

BET5D – ST – M 12 N – 40

Type of slider M : Medium slider	Lead 06 : 6mm 12 : 12mm	Brake N : Without brake B : With brake	Stroke Type designation
-------------------------------------	-------------------------------	--	----------------------------

Ball-screw driven

BET5D-ST

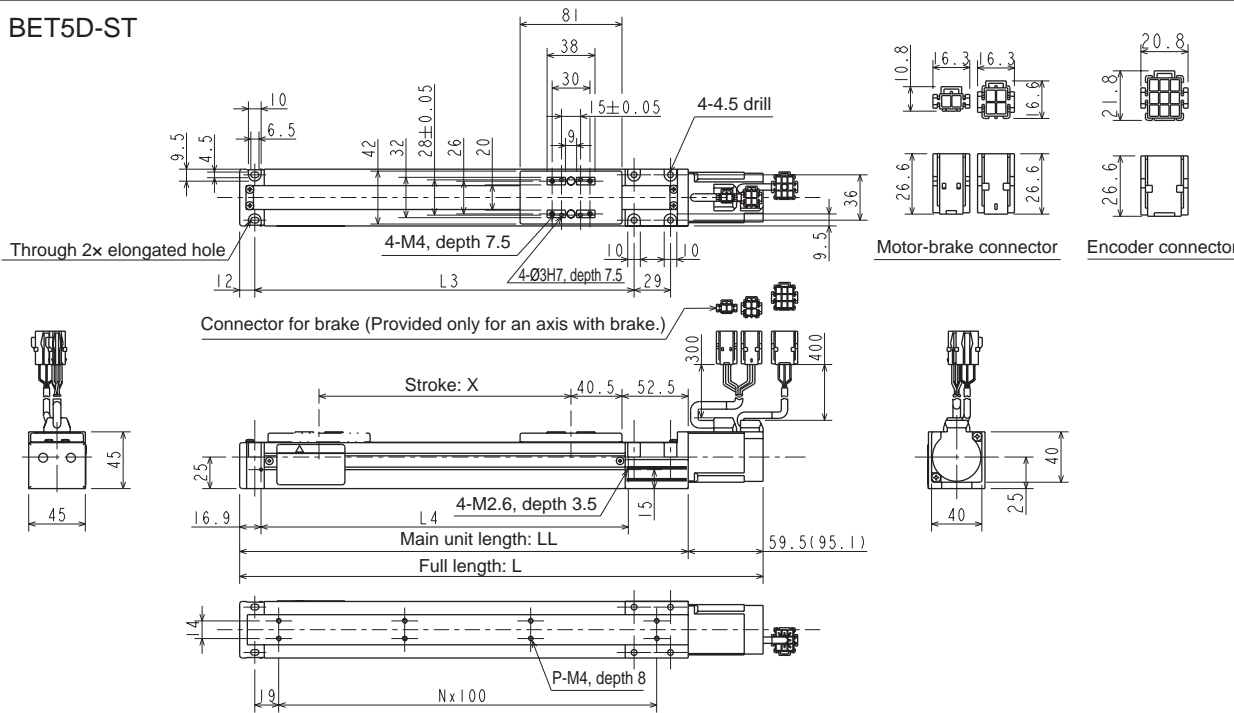

Stroke X (mm)	50	100	150	200	250	300	350	400	450	500
Full length L (mm)	265.5 (301.1)	315.5 (351.1)	365.5 (401.1)	415.5 (451.1)	465.5 (501.1)	515.5 (551.1)	565.5 (601.1)	615.5 (651.1)	665.5 (701.1)	715.5 (751.1)
Main unit length LL (mm)	206	256	306	356	406	456	506	556	606	656
L3 (mm)	151	201	251	301	351	401	451	501	551	601
L4 (mm)	141.6	191.6	241.6	291.6	341.6	391.6	441.6	491.6	541.6	591.6
No. of holes P (q'ty)	4	6	6	8	8	10	10	12	12	14
Intervals between mounting holes N	1	2	2	3	3	4	4	5	5	6
Weight (kg)	1.2 (1.4)	1.3 (1.5)	1.4 (1.6)	1.5 (1.7)	1.6 (1.8)	1.7 (1.9)	1.8 (2.0)	1.9 (2.1)	2.0 (2.2)	2.1 (2.3)

* Values in parentheses are for the axis with brake.

[Set designation]

BA3 – T7D – ST – M 12 N – 40 – 13

Type of slider M : Medium slider	Lead 06 : 6mm 12 : 12mm	Brake N : Without brake B : With brake	Stroke Type designation	Controller (CA25-M10) 0 : None 1 : NPN output specifications Other : See page 19	Cable length 3 : 3m 9 : 9m 5 : 5m B : 11m 7 : 7m D : 13m
-------------------------------------	-------------------------------	--	----------------------------	---	---

[Specifications]

Motor	50 W AC servo motor (absolute)			
Drive system	Precisely rolled ball screw, thread outer diameter 12 mm			
Stroke (mm) (in increments of 50 mm)	Medium slider	50 ~ 550	600	700
	Type designation	05 ~ 55	60	70
Maximum speed (mm/s)	Lead 12 mm	800	680	500
	Lead 6 mm	400	340	250
Maximum payload (kg) Acceleration/deceleration time: 0.3 sec or over	Lead 12 mm	Horizontal transfer: 12 Vertical transfer: 4		
	Lead 6 mm	Horizontal transfer: 30 Vertical transfer: 8		
Positioning repeatability (mm)	± 0.02			
Resolution (mm)	0.01			
Allowable static load moment (N·m)	Medium slider MR : 58 MP : 25.7 MY : 25.7			
Brake	Brake voltage DC24 V			
Master controller	CA25-M10			

- Notes:
- * When using the axis as a vertical axis, select the type with brake.
 - * The maximum payload signifies a load exerted on top of the slider. Also refers to the description on the dynamic load moment appearing later in this document.
 - * The acceleration/deceleration time represents the time until the axis reaches a programmed speed.

[Axis designation]

BET7D – ST – M 12 N – 40

Type of slider M : Medium slider	Lead 06 : 6mm 12 : 12mm	Brake N : Without brake B : With brake	Stroke Type designation
-------------------------------------	-------------------------------	--	----------------------------

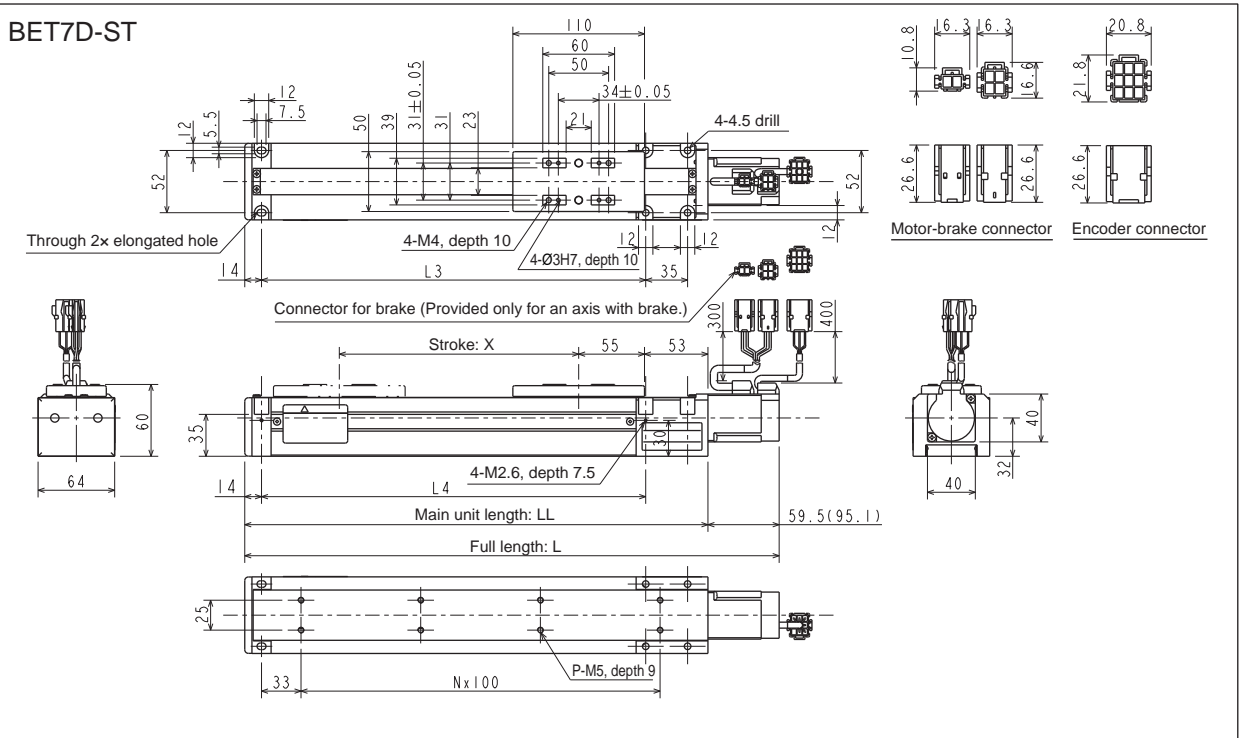

Stroke X (mm)	50	100	150	200	250	300	350	400	450	500	550	600	700
Full length L (mm)	296.5 (332.1)	346.5 (382.1)	396.5 (432.1)	446.5 (482.1)	496.5 (532.1)	546.5 (582.1)	596.5 (632.1)	646.5 (682.1)	696.5 (732.1)	746.5 (782.1)	796.5 (832.1)	846.5 (882.1)	946.5 (982.1)
Main unit length LL (mm)	237	287	337	387	437	487	537	587	637	687	737	787	887
L3 (mm)	171	221	271	321	371	421	471	521	571	621	671	721	821
L4 (mm)	171	221	271	321	371	421	471	521	571	621	671	721	821
No. of holes P (q'ty)	4	6	6	8	8	10	10	12	12	14	14	16	18
Intervals between mounting holes N	1	2	2	3	3	4	4	5	5	6	6	7	8
Weight (kg)	2.3 (2.5)	2.5 (2.7)	2.7 (2.9)	2.9 (3.1)	3.1 (3.3)	3.3 (3.5)	3.5 (3.7)	3.7 (3.9)	3.9 (4.1)	4.1 (4.3)	4.3 (4.5)	4.5 (4.7)	4.9 (5.1)

* Values in parentheses are for the axis with brake.

[Set designation]

BA3 – 10E – ST – M 20 N – 40 – 1 3

Axis structure	Type of slider	Lead	Brake	Stroke	Controller (CA25-M10)	Cable length
ST : Straight axis UR : Right side mounted motor axis UL : Left side mounted motor axis UU : Bottom side mounted motor axis	S : Short slider M : Medium slider	05 : 5mm 10 : 10mm 20 : 20mm	N : Without brake B : With brake	Type designation	0 : None 1 : NPN output specifications Other : See page 19	3 : 3m 9 : 9m 5 : 5m B : 11m 7 : 7m D : 13m

[Specifications]

Motor	100 W AC servo motor (absolute)					
Drive system	Ground ball screw (C7), thread outer diameter 15 mm					
Stroke (mm) (in increments of 100 mm)	Short slider	150~650	750	850	950, 1050	1150, 1250
	Type designation	15~65	75	85	95, A5	B5, C5
	Medium slider	100~600	700	800	900, 1000	1100, 1200
	Type designation	10~60	70	80	90, A0	B0, C0
Maximum speed (mm/s) Values in < > signify the acceleration/deceleration time in seconds when the maximum payload is loaded.	Lead 20 mm	1200<0.36>	1000<0.3>	800<0.24>	600<0.18>	400<0.12>
	Lead 10 mm	600<0.36>	500<0.3>	400<0.24>	300<0.18>	200<0.12>
	Lead 5 mm	300<0.36>	250<0.3>	200<0.24>	150<0.18>	
Maximum payload (kg)	Lead 20 mm	Horizontal transfer: 20		Vertical transfer: 3 (5)		
	Lead 10 mm	Horizontal transfer: 40		Vertical transfer: 8 (12)		
	Lead 5 mm	Horizontal transfer: 80		Vertical transfer: 15 (22)		
Positioning repeatability (mm)	± 0.01					
Resolution (mm)	0.01					
Allowable static load moment (N·m)	Short slider MR : 49 MP : 14 MY : 13 Medium slider MR : 59 MP : 59 MY : 54					
Brake	Brake voltage DC24 V					
Master controller	CA25-M10					

- Notes: * When using the axis as a vertical axis, select the type with brake.
 * The maximum payload signifies a load exerted on top of the slider. Also refers to the description on the dynamic load moment appearing later in this document.
 * The values in parentheses under "Maximum payload" are applicable when a regenerative discharge unit ABSU-2000 is equipped.
 * The acceleration/deceleration time represents the time until the axis reaches a programmed speed.

[Axis designation]

BE10E – ST – M 20 N – 40

Axis structure	Type of slider	Lead	Brake	Stroke
ST : Straight axis UR : Right side mounted motor axis UL : Left side mounted motor axis UU : Bottom side mounted motor axis	S : Short slider M : Medium slider	05 : 5mm 10 : 10mm 20 : 20mm	N : Without brake B : With brake	Type designation

[Dimensions]

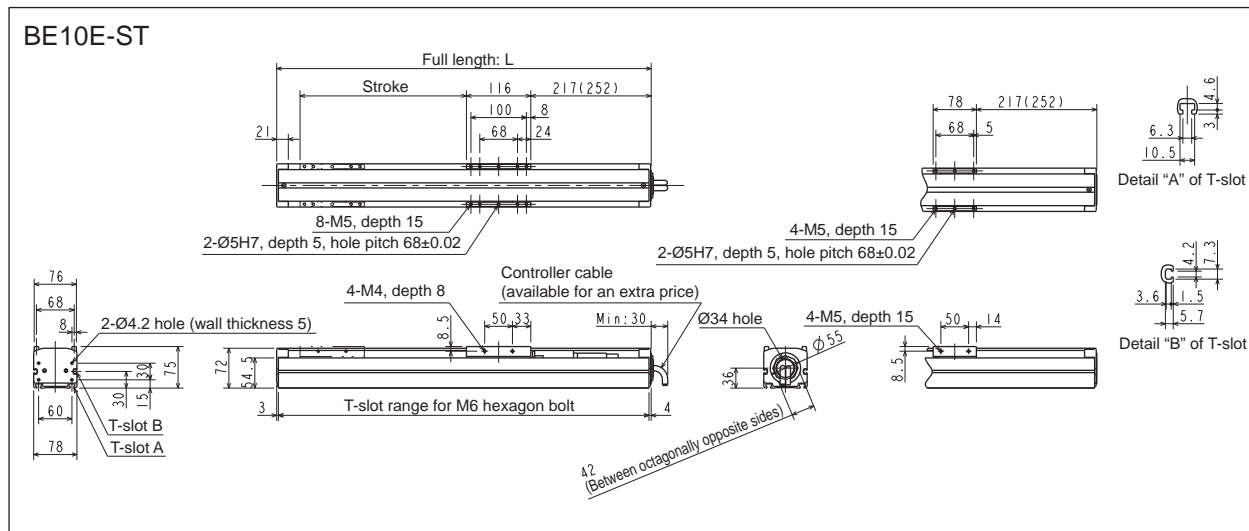

Straight axis

Medium slider stroke (mm)	100	200	300	400	500	600	700	800	900	1000	1100	1200
Full length L (mm)	475 (510)	575 (610)	675 (710)	775 (810)	875 (910)	975 (1010)	1075 (1110)	1175 (1210)	1275 (1310)	1375 (1410)	1475 (1510)	1575 (1610)
Weight (kg)	4.8 (5.1)	5.5 (5.8)	6.2 (6.5)	6.9 (7.2)	7.6 (7.9)	8.3 (8.6)	9.0 (9.3)	9.7 (10.0)	10.4 (10.7)	11.1 (11.4)	11.8 (12.1)	12.5 (12.8)

* Values in parentheses are for the axis with brake.

Short slider stroke (mm)	150	250	350	450	550	650	750	850	950	1050	1150	1250
Full length L (mm)	475 (510)	575 (610)	675 (710)	775 (810)	875 (910)	975 (1010)	1075 (1110)	1175 (1210)	1275 (1310)	1375 (1410)	1475 (1510)	1575 (1610)
Weight (kg)	4.5 (4.8)	5.2 (5.5)	5.9 (6.2)	6.6 (6.9)	7.3 (7.6)	8.0 (8.3)	8.7 (9.0)	9.4 (9.7)	10.1 (10.4)	10.8 (11.1)	11.5 (11.8)	12.2 (12.5)

* Values in parentheses are for the axis with brake.

BE10E-UR

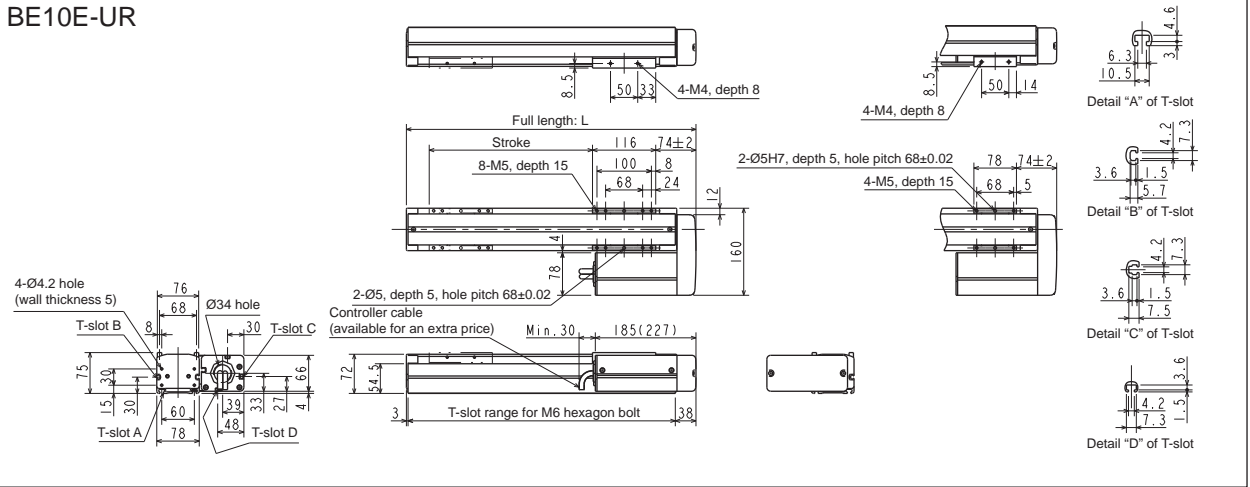

BE10E-UL

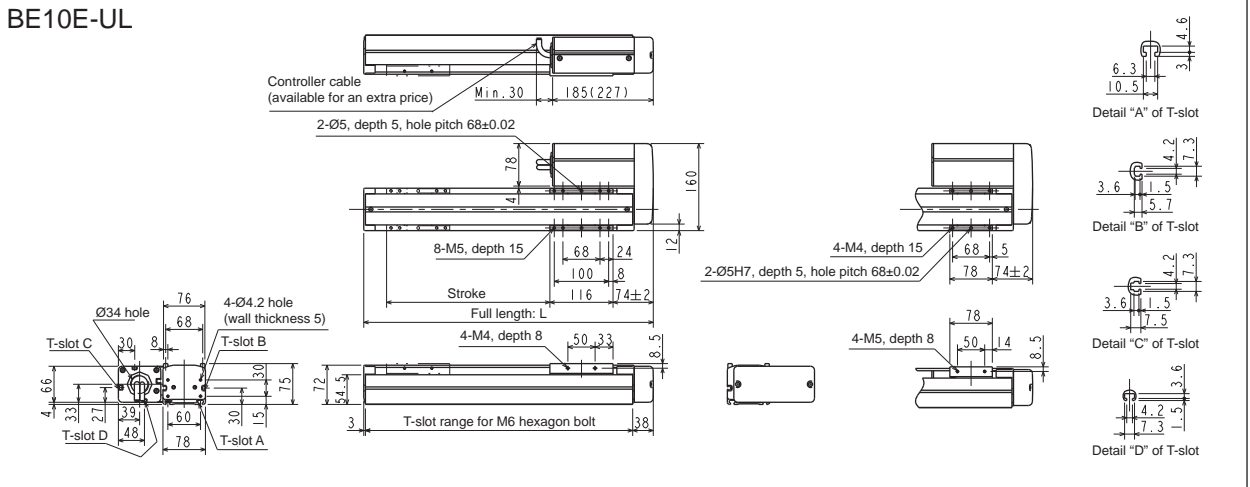

BE10E-UU

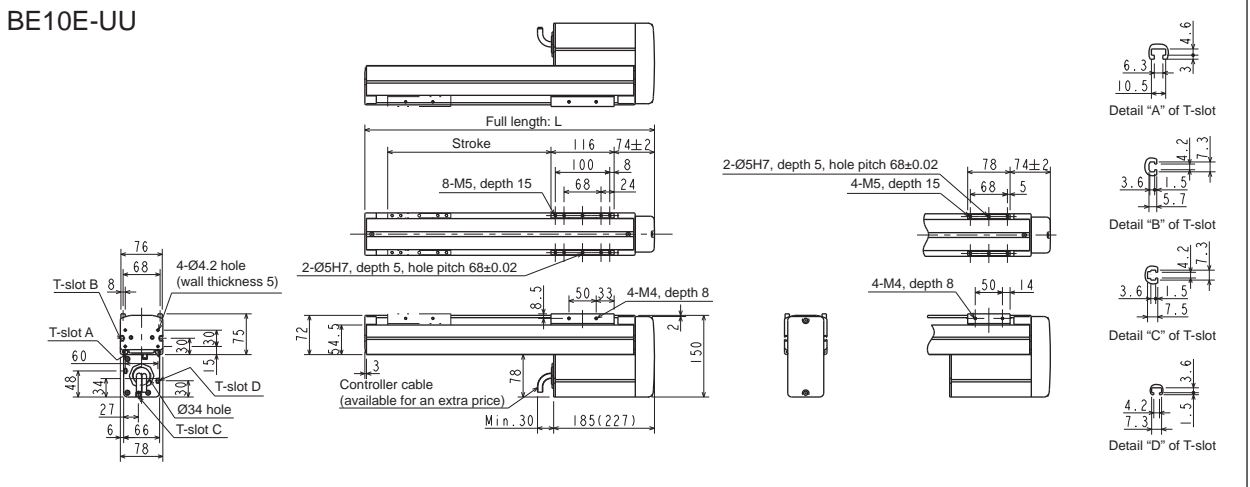

Mounted motor axis

Medium slider stroke (mm)	100	200	300	400	500	600	700	800	900	1000	1100	1200
Full length L (mm)	332	432	532	632	732	832	932	1032	1132	1232	1332	1432
Weight (kg)	5.0 (5.3)	5.7 (6.0)	6.4 (6.7)	7.1 (7.4)	7.8 (8.1)	8.5 (8.8)	9.2 (9.5)	9.9 (10.2)	10.6 (10.9)	11.3 (11.6)	12.0 (12.3)	12.7 (13.0)

Note 1: Values in parentheses are for axis with brake.

Note 2: The BE10-UU type supports strokes of 200 mm or more.

Short slider stroke (mm)	150	250	350	450	550	650	750	850	950	1050	1150	1250
Full length L (mm)	332	432	532	632	732	832	932	1032	1132	1232	1332	1432
Weight (kg)	4.7 (5.0)	5.4 (5.7)	6.1 (6.4)	6.8 (7.1)	7.5 (7.8)	8.2 (8.5)	8.9 (9.2)	9.6 (9.9)	10.3 (10.6)	11.0 (11.3)	11.7 (12.0)	12.4 (12.7)

Note 1: Values in parentheses are for axis with brake.

Note 2: The BE10-UU type supports strokes of 250 mm or more.

[Set designation]

BA3 – 30E – ST – M 20 N – 45 – 13

Axis structure	Type of slider	Lead	Brake	Stroke	Controller (CA25-M10)	Cable length
ST : Straight axis UR : Right side mounted motor axis UL : Left side mounted motor axis UU : Bottom side mounted motor axis	M : Medium slider L : Long slider	05 : 5mm 10 : 10mm 20 : 20mm	N : Without brake B : With brake	Type designation	0 : None 1 : NPN output specifications Other : See page 19	3 : 3m 9 : 9m 5 : 5m B : 11m 7 : 7m D : 13m

[Specifications]

Motor	100 W AC servo motor (absolute)					
Drive system	Ground ball screw (C7), thread outer diameter 15 mm					
Stroke (mm) (in increments of 100 mm)	Medium slider	100~600 [150~650]	700 [750]	800 [850]	900, 1000 [950, 1050]	1100, 1200 [1150, 1250]
	Type designation	10~60 [15~65]	70 [75]	80 [85]	90, A0 [95, A5]	B0, C0 [B5, C5]
Maximum speed (mm/s) Values in <> signify the acceleration/deceleration time in seconds when the maximum payload is loaded.	Long slider	150~550 [150~650]	650 [750]	750 [850]	850, 950 [950, 1050]	1050, 1150 [1150, 1250]
	Type designation	15~55	65 [75]	75 [85]	85, 95 [95, A5]	A5, B5 [B5, C5]
Maximum payload (kg)	Lead 20 mm	Horizontal transfer: 30		Vertical transfer: 3 (5)		
	Lead 10 mm	Horizontal transfer: 55		Vertical transfer: 8 (12)		
	Lead 5 mm	Horizontal transfer: 80		Vertical transfer: 15 (22)		
Positioning repeatability (mm)	± 0.01					
Resolution (mm)	0.01					
Allowable static load moment (N-m)	Medium slider MR : 510 MP : 430 MY : 370 Long slider MR : 510 MP : 750 MY : 650					
Brake	Brake voltage DC24 V					
Master controller	CA25-M10					

- Notes:
- * When using the axis as a vertical axis, select the type with brake.
 - * The maximum payload signifies a load exerted on top of the slider. Also refers to the description on the dynamic load moment appearing later in this document.
 - * The values in parentheses under "Maximum payload" are applicable when a regenerative discharge unit ABSU-2000 is equipped.
 - * The acceleration/deceleration time represents the time until the axis reaches a programmed speed.

[Axis designation]

BE30E – ST – M 20 N – 45

Axis structure	Type of slider	Lead	Brake	Stroke
ST : Straight axis UR : Right side mounted motor axis UL : Left side mounted motor axis UU : Bottom side mounted motor axis	M : Medium slider L : Long slider	05 : 5mm 10 : 10mm 20 : 20mm	N : Without brake B : With brake	Type designation

[Dimensions]

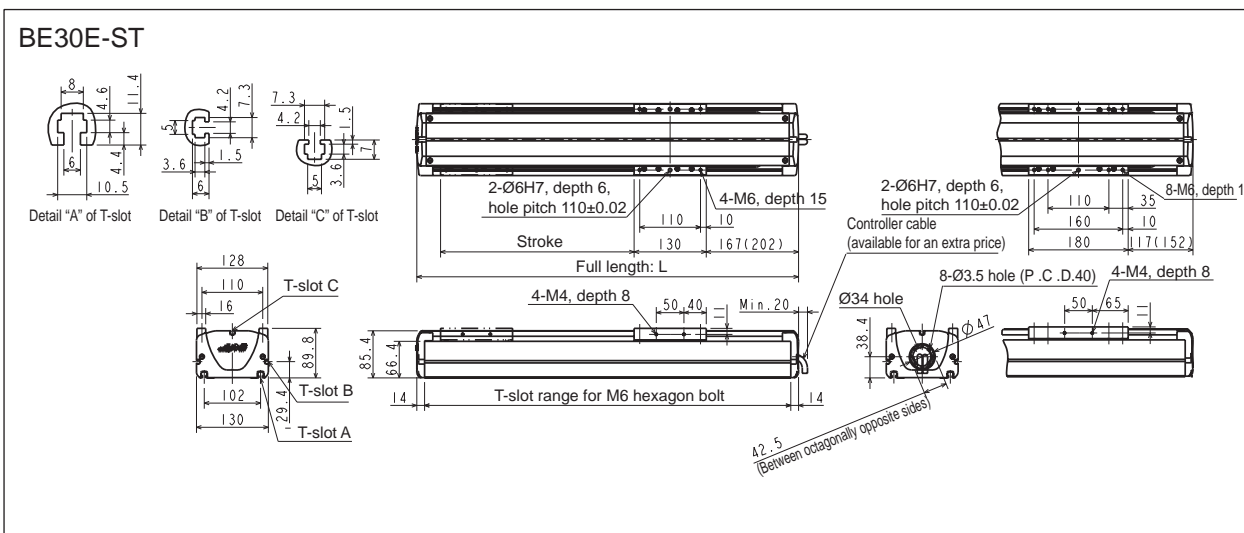

Straight axis

Medium slider stroke (mm)	150	250	350	450	550	650	750	850	950	1050	1150	1250
Full length L (mm)	490 (525)	590 (625)	690 (725)	790 (825)	890 (925)	990 (1025)	1090 (1125)	1190 (1225)	1290 (1325)	1390 (1425)	1490 (1525)	1590 (1625)
Weight (kg)	8.1 (8.6)	9.3 (9.8)	10.5 (11.0)	11.7 (12.2)	12.9 (13.4)	14.1 (14.6)	15.3 (15.8)	16.5 (17.0)	17.7 (18.2)	18.9 (19.4)	20.1 (20.6)	21.3 (21.8)

* Values in parentheses are for the axis with brake.

Long slider stroke (mm)	150	250	350	450	550	650	750	850	950	1050	1150	1250
Full length L (mm)	490 (525)	590 (625)	690 (725)	790 (825)	890 (925)	990 (1025)	1090 (1125)	1190 (1225)	1290 (1325)	1390 (1425)	1490 (1525)	1590 (1625)
Weight (kg)	8.4 (8.9)	9.6 (10.1)	10.8 (11.3)	12.0 (12.5)	13.2 (13.7)	14.4 (14.9)	15.6 (16.1)	16.8 (17.3)	18.0 (18.5)	19.2 (19.7)	20.4 (20.9)	21.6 (22.1)

* Values in parentheses are for the axis with brake.

BE30E-UR

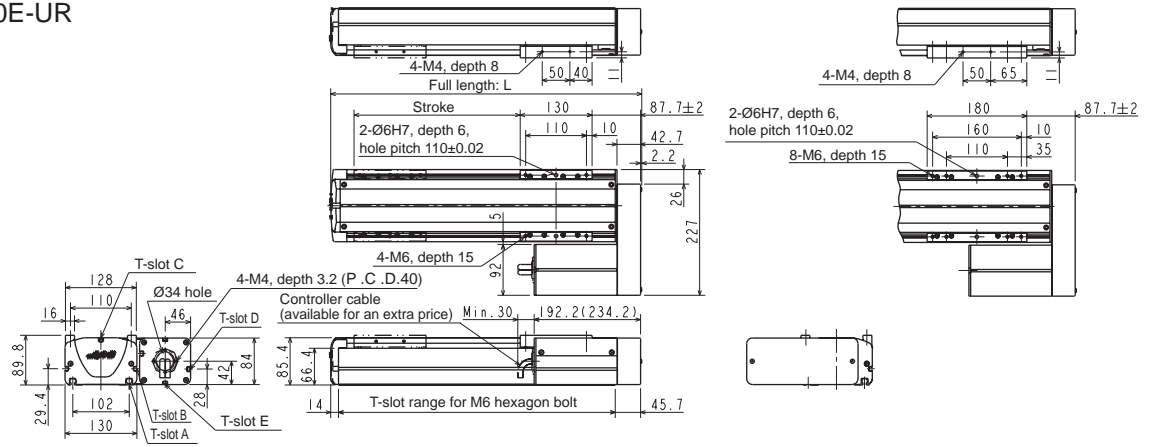

BE30E-UL

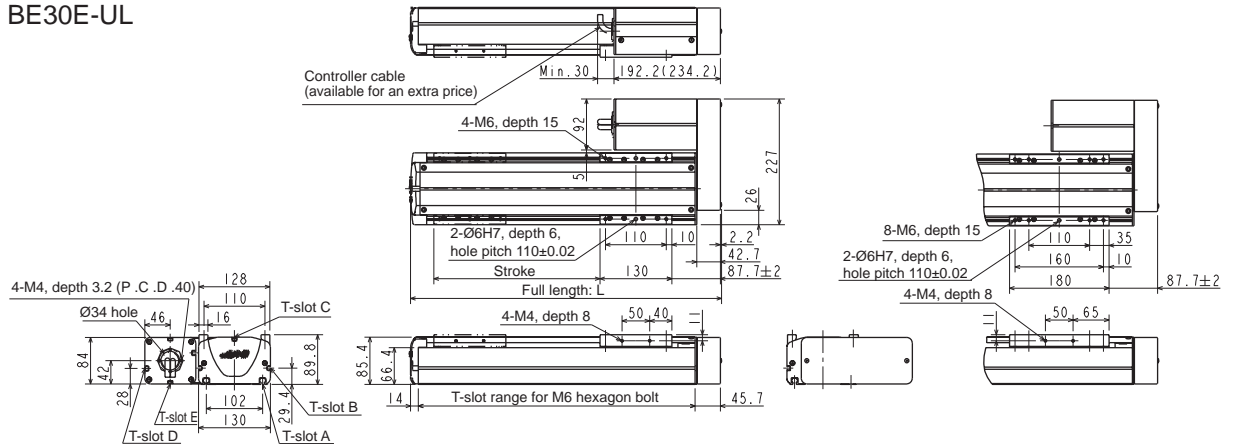

BE30E-UU

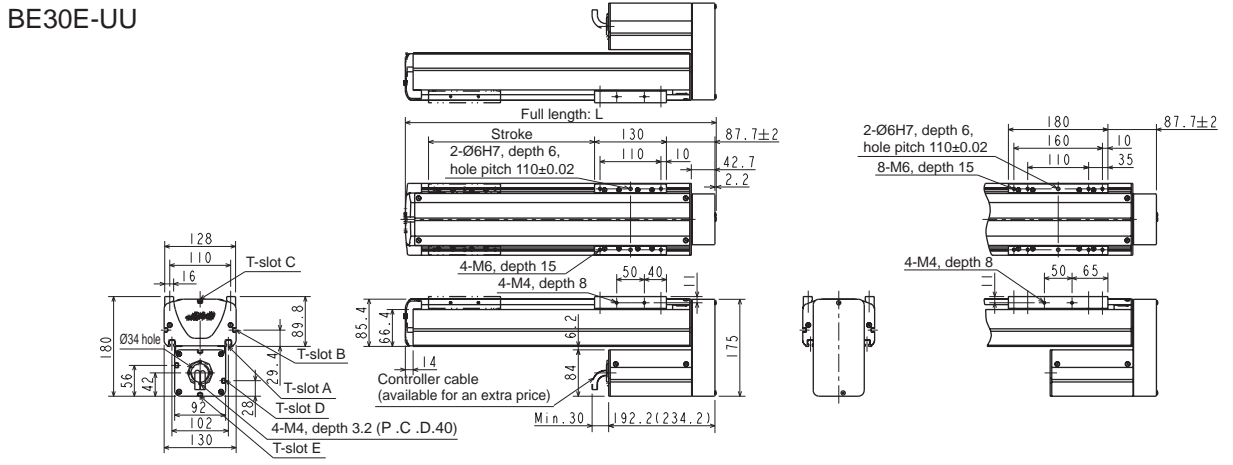

Common to BE30E-UR, UL and UU.

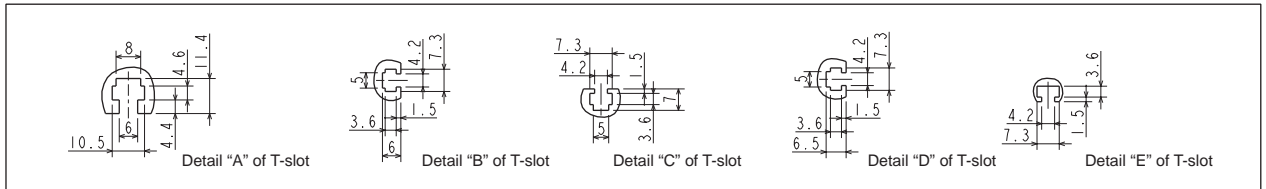

Mounted motor axis

Medium slider stroke (mm)	100	200	300	400	500	600	700	800	900	1000	1100	1200
Full length L (mm)	361.9	461.9	561.9	661.9	761.9	861.9	961.9	1061.9	1161.9	1261.9	1361.9	1461.9
Weight (kg)	7.8 (8.1)	9.0 (9.3)	10.2 (10.5)	11.4 (11.7)	12.6 (12.9)	13.8 (14.1)	15.0 (15.3)	16.2 (16.5)	17.4 (17.7)	18.6 (18.9)	19.8 (20.1)	21.0 (21.3)

* Values in parentheses are for the axis with brake.

Long slider stroke (mm)	150	250	350	450	550	650	750	850	950	1050	1150
Full length L (mm)	461.9	561.9	661.9	761.9	861.9	961.9	1061.9	1161.9	1261.9	1361.9	1461.9
Weight (kg)	9.3 (9.6)	10.5 (10.8)	11.7 (12.0)	12.9 (13.2)	14.1 (14.4)	15.3 (15.6)	16.5 (16.8)	17.7 (18.0)	18.9 (19.2)	20.1 (20.4)	21.3 (21.6)

* Values in parentheses are for the axis with brake.

[Set designation]

BA3 – 30F – ST – M 20 N – 40 – 1 3

Axis structure	Type of slider	Lead	Brake	Stroke	Controller (CA25-M10)	Cable length
ST : Straight axis UR : Right side mounted motor axis UL : Left side mounted motor axis UU : Bottom side mounted motor axis	M : Medium slider L : Long slider	05 : 5mm 10 : 10mm 20 : 20mm	N : Without brake B : With brake	Type designation	0 : None 1 : NPN output specifications Other : See page 19	3 : 3m 9 : 9m 5 : 5m B : 11m 7 : 7m D : 13m

[Specifications]

Motor	200 W AC servo motor (absolute)					
Drive system	Ground ball screw (C7), thread outer diameter 15 mm					
Stroke (mm) (in increments of 100 mm)	Medium slider	100~600	700	800	900, 1000	1100, 1200
	Type designation	10~60	70	80	90, A0	B0, C0
	Long slider	150~550	650	750	850, 950	1050, 1150
	Type designation	15~55	65	75	85, 95	A5, B5
Maximum speed (mm/s) Values in < > signify the acceleration/deceleration time in seconds when the maximum payload is loaded.	Lead 20 mm	1200<0.36>	1000<0.3>	800<0.24>	600<0.18>	400<0.12>
	Lead 10 mm	600<0.36>	500<0.3>	400<0.24>	300<0.18>	200<0.12>
	Lead 5 mm	300<0.36>	250<0.3>	200<0.24>	150<0.18>	
Maximum payload (kg)	Lead 20 mm	Horizontal transfer: 40 Vertical transfer: 3 (10)				
	Lead 10 mm	Horizontal transfer: 80 Vertical transfer: 8 (20)				
	Lead 5 mm	Horizontal transfer: 100 Vertical transfer: 15 (40)				
Positioning repeatability (mm)	± 0.01					
Resolution (mm)	0.01					
Allowable static load moment (N·m)	Medium slider	MR : 510	MP : 430	MY : 370	Long slider	MR : 510 MP : 750 MY : 650
Brake	Brake voltage DC24 V					
Master controller	CA25-M10					

- Notes:
- * When using the axis as a vertical axis, select the type with brake.
 - * The maximum payload signifies a load exerted on top of the slider. Also refers to the description on the dynamic load moment appearing later in this document.
 - * The values in parentheses under "Maximum payload" are applicable when a regenerative discharge unit ABSU-2000 is equipped.
 - * The acceleration/deceleration time represents the time until the axis reaches a programmed speed.

[Axis designation]

BE30F – ST – M 20 N – 40

Axis structure	Type of slider	Lead	Brake	Stroke
ST : Straight axis UR : Right side mounted motor axis UL : Left side mounted motor axis UU : Bottom side mounted motor axis	M : Medium slider L : Long slider	05 : 5mm 10 : 10mm 20 : 20mm	N : Without brake B : With brake	Type designation

[Dimensions]

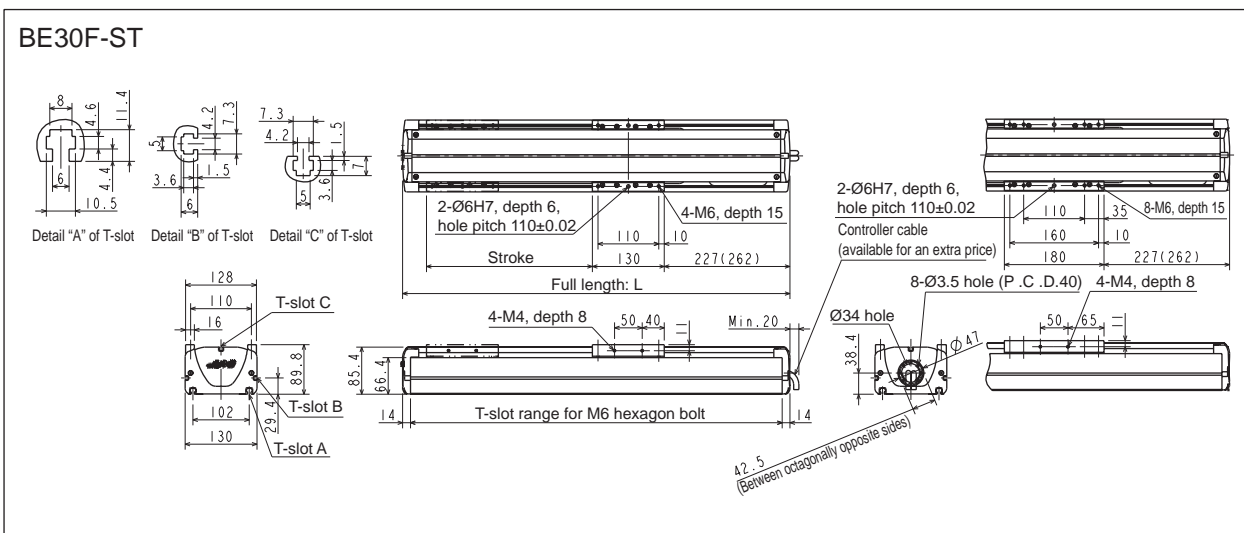

Straight axis

Medium slider stroke (mm)	100	200	300	400	500	600	700	800	900	1000	1100	1200
Full length L (mm)	500 (535)	600 (635)	700 (735)	800 (835)	900 (935)	1000 (1035)	1100 (1135)	1200 (1235)	1300 (1335)	1400 (1435)	1500 (1535)	1600 (1635)
Weight (kg)	9.2 (9.8)	10.4 (11.0)	11.6 (12.2)	12.8 (13.4)	14.0 (14.6)	15.2 (15.8)	16.4 (17.0)	17.6 (18.2)	18.8 (19.4)	20.0 (20.6)	21.2 (21.8)	22.4 (23.0)

* Values in parentheses are for the axis with brake.

Long slider stroke (mm)	150	250	350	450	550	650	750	850	950	1050	1150
Full length L (mm)	600 (635)	700 (735)	800 (835)	900 (935)	1000 (1035)	1100 (1135)	1200 (1235)	1300 (1335)	1400 (1435)	1500 (1535)	1600 (1635)
Weight (kg)	10.7 (11.3)	11.9 (12.5)	13.1 (13.7)	14.3 (14.9)	15.5 (16.1)	16.7 (17.3)	17.9 (18.5)	19.1 (19.7)	20.3 (20.9)	21.5 (22.1)	22.7 (23.3)

* Values in parentheses are for the axis with brake.

BE30F-UR

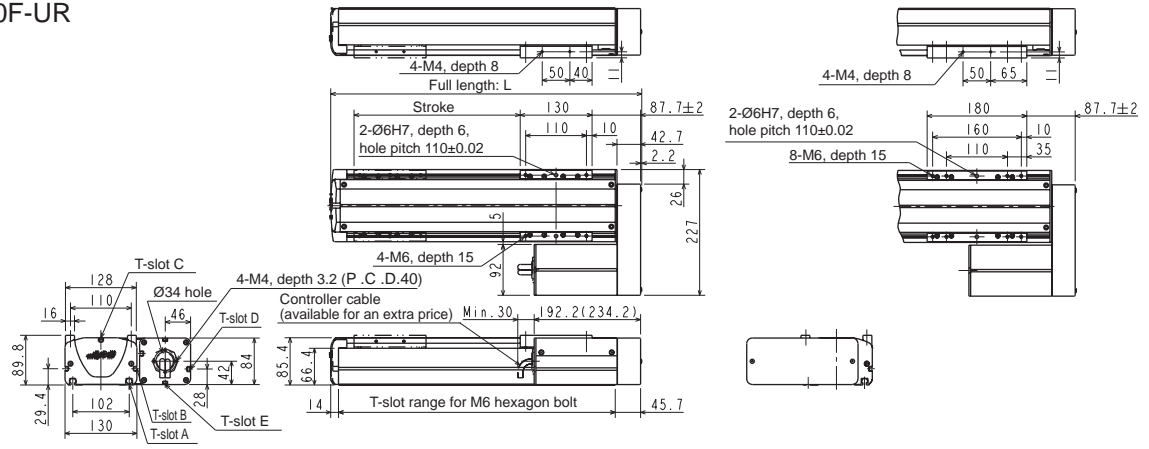

BE30F-UL

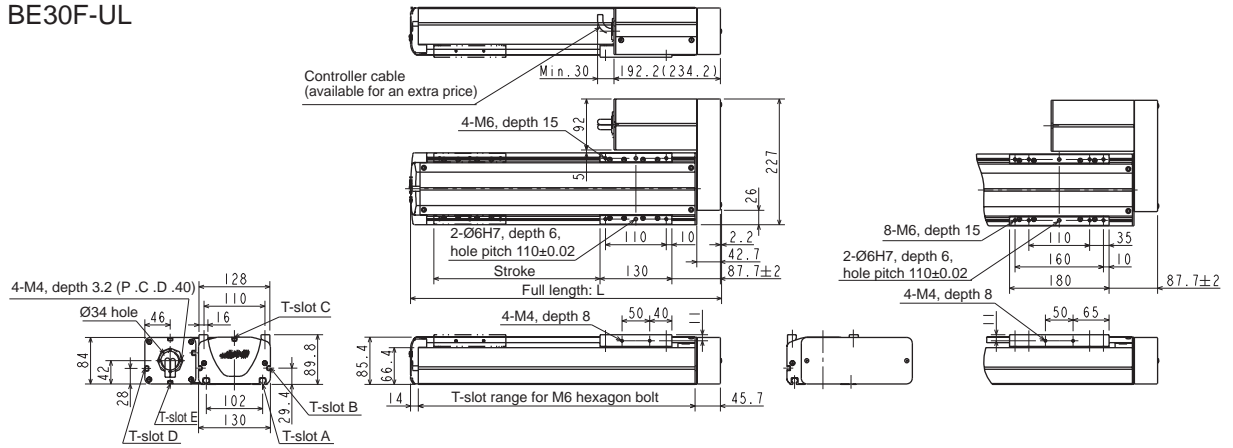

BE30F-UU

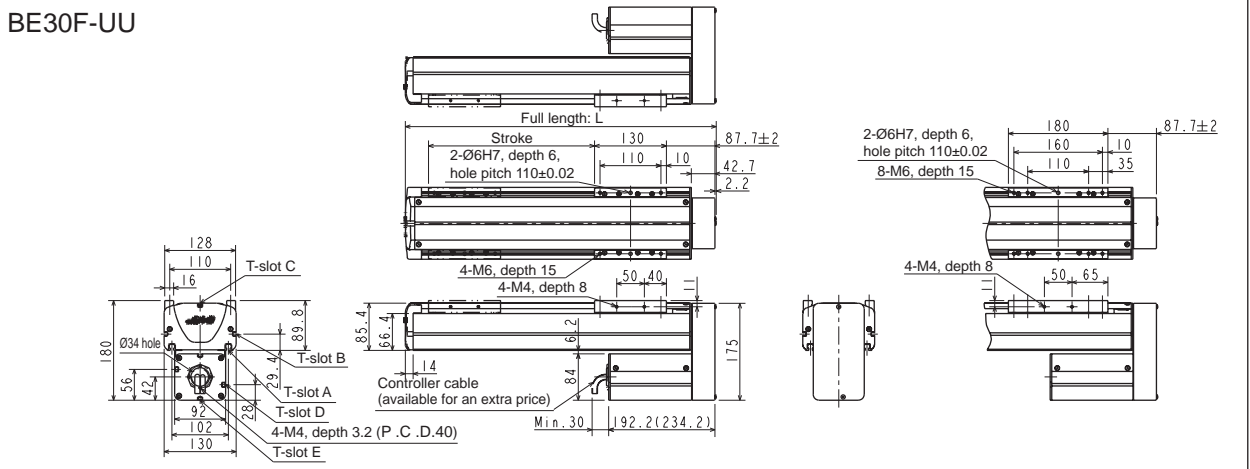

Common to BE30F-UR, UL and UU.

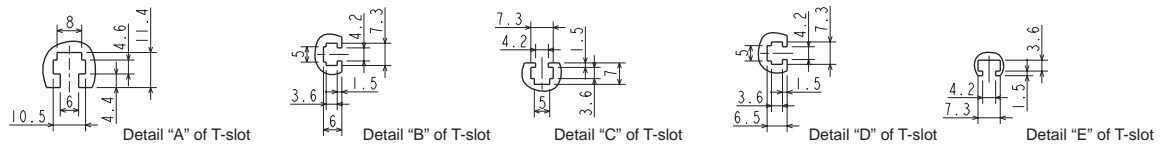

Mounted motor axis

Medium slider stroke (mm)	100	200	300	400	500	600	700	800	900	1000	1100	1200
Full length L (mm)	361.9	461.9	561.9	661.9	761.9	861.9	961.9	1061.9	1161.9	1261.9	1361.9	1461.9
Weight (kg)	8.3 (8.9)	9.5 (10.1)	10.7 (11.3)	11.9 (12.5)	13.1 (13.7)	14.3 (14.9)	15.5 (16.1)	16.7 (17.3)	17.9 (18.5)	19.1 (19.7)	20.3 (20.9)	21.5 (22.1)

* Values in parentheses are for the axis with brake.

Long slider stroke (mm)	150	250	350	450	550	650	750	850	950	1050	1150
Full length L (mm)	461.9	561.9	661.9	761.9	861.9	961.9	1061.9	1161.9	1261.9	1361.9	1461.9
Weight (kg)	9.8 (10.3)	11.0 (11.6)	12.2 (12.8)	13.4 (14.0)	14.6 (15.2)	15.8 (16.4)	17.0 (17.6)	18.2 (18.8)	19.4 (20.0)	20.6 (21.2)	21.8 (22.4)

* Values in parentheses are for the axis with brake.

[Set designation]

BA3 – 50F – ST – M 20 N – 40 – 1 3

Axis structure	Type of slider	Lead	Brake	Stroke	Controller (CA25-M10)	Cable length
ST : Straight axis UR : Right side mounted motor axis UL : Left side mounted motor axis UU : Bottom side mounted motor axis	M : Medium slider L : Long slider	05 : 5mm 10 : 10mm 20 : 20mm	N : Without brake B : With brake	Type designation	0 : None 1 : NPN output specifications Other : See page 19	3 : 3m 9 : 9m 5 : 5m B : 11m 7 : 7m D : 13m

[Specifications]

Motor	200 W AC servo motor (absolute)									
Drive system	Ground ball screw (C7), thread outer diameter 20 mm									
Stroke (mm) (in increments of 100 mm)	Medium slider	200~600	700, 800	900, 1000	1100, 1200	1300	1400	1500	1600	
	Type designation	20~60	70, 80	90, A0	B0, C0	D0	E0	F0	G0	
	Long slider	250~550	650, 750	850, 950	1050, 1150	1250	1350	1450	1550	
Maximum speed (mm/s) Values in < > signify the acceleration/deceleration time in seconds when the maximum payload is loaded.	Type designation	25~55	65, 75	85, 95	A5, B5	C5	D5	E5	F5	
	Lead 20 mm	1200<0.36>	1100<0.33>	1000<0.3>	700<0.21>	500<0.15>	400<0.12>	300<0.1>	300<0.10>	
	Lead 10 mm	600<0.36>	550<0.33>	500<0.3>	350<0.21>	250<0.15>	200<0.12>	150<0.1>	150<0.10>	
Maximum payload (kg)	Lead 5 mm	300<0.36>	280<0.33>	250<0.3>	180<0.21>	130<0.15>	100<0.12>	80<0.1>	80<0.10>	
	Lead 20 mm	Horizontal transfer: 60 (Note 1)			Vertical transfer: 3					
	Lead 10 mm	Horizontal transfer: 100			Vertical transfer: 8 (25)					
Positioning repeatability (mm)	Lead 5 mm	Horizontal transfer: 100			Vertical transfer: 15 (50)					
	±0.01									
Resolution (mm)	0.01									
Allowable static load moment (N·m)	Medium slider MR : 2080 MP : 2160 MY : 1820 Long slider MR : 2080 MP : 3150 MY : 2640									
Brake	Brake voltage DC24 V									
Master controller	CA25-M10									

- Notes: * When using the axis as a vertical axis, select the type with brake.
 * The maximum payload signifies a load exerted on top of the slider. Also refers to the description on the dynamic load moment appearing later in this document.
 * The values in parentheses under "Maximum payload" are applicable when a regenerative discharge unit ABSU-2000 is equipped.
 * The acceleration/deceleration time represents the time until the axis reaches a programmed speed.

Note 1: When master power voltage is 110 to 120 V or 220 V to 240 V with payload larger than 50 kg, a regenerative discharge unit (ABSU-2000) is required. When the axis speed exceeds 1,000 mm/s, allowable payload is 50 kg.

[Axis designation]

BE50F – ST – M 20 N – 40

Axis structure	Type of slider	Lead	Brake	Stroke
ST : Straight axis UR : Right side mounted motor axis UL : Left side mounted motor axis UU : Bottom side mounted motor axis	M : Medium slider L : Long slider	05 : 5mm 10 : 10mm 20 : 20mm	N : Without brake B : With brake	Type designation

[Dimensions]

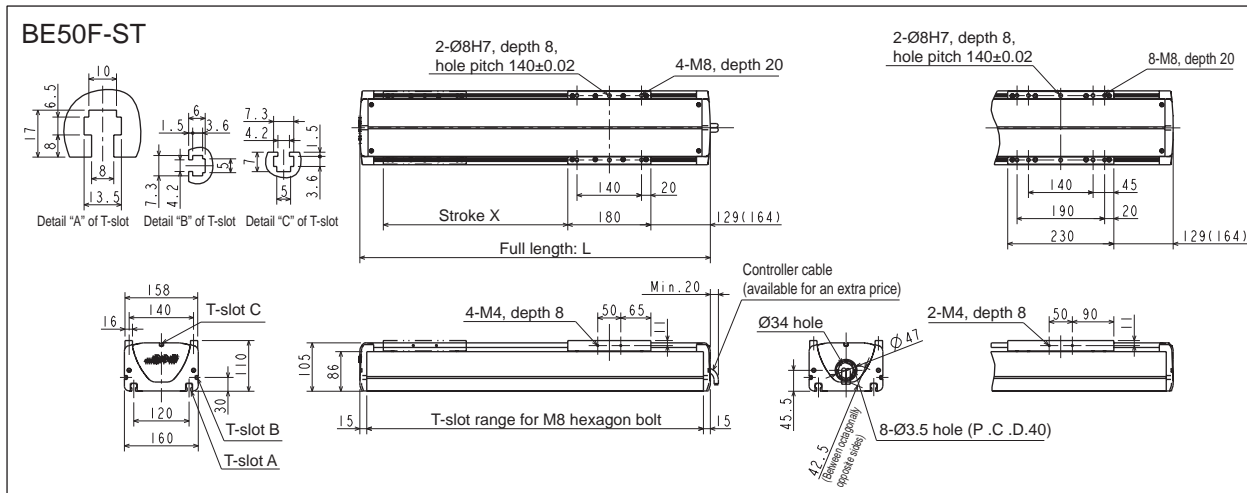

Straight axis

Medium slider stroke (mm)	200	300	400	500	600	700	800	900	1000	1100	1200	1300	1400	1500	1600
Full length L (mm)	560 (595)	660 (695)	760 (795)	860 (895)	960 (995)	1060 (1095)	1160 (1195)	1260 (1295)	1360 (1395)	1460 (1495)	1560 (1595)	1660 (1695)	1760 (1795)	1860 (1895)	1960 (1995)
Weight (kg)	15.6 (16.4)	17.5 (18.3)	19.4 (20.2)	21.3 (22.1)	23.2 (24.0)	25.1 (25.9)	27.0 (27.8)	28.9 (29.7)	30.8 (31.6)	32.7 (33.5)	34.6 (35.4)	36.5 (37.3)	38.4 (39.2)	40.3 (41.1)	42.2 (43.0)

* Values in parentheses are for the axis with brake.

Long slider stroke (mm)	250	350	450	550	650	750	850	950	1050	1150	1250	1350	1450	1550
Full length L (mm)	660 (695)	760 (795)	860 (895)	960 (995)	1060 (1095)	1160 (1195)	1260 (1295)	1360 (1395)	1460 (1495)	1560 (1595)	1660 (1695)	1760 (1795)	1860 (1895)	1960 (1995)
Weight (kg)	18.1 (18.9)	20.0 (20.8)	21.9 (22.7)	23.8 (24.6)	25.7 (26.5)	27.6 (28.4)	29.5 (30.3)	31.4 (32.2)	33.3 (34.1)	35.2 (36.0)	37.1 (37.9)	39.0 (39.8)	40.9 (41.7)	42.8 (43.6)

* Values in parentheses are for the axis with brake.

BE50F-UR

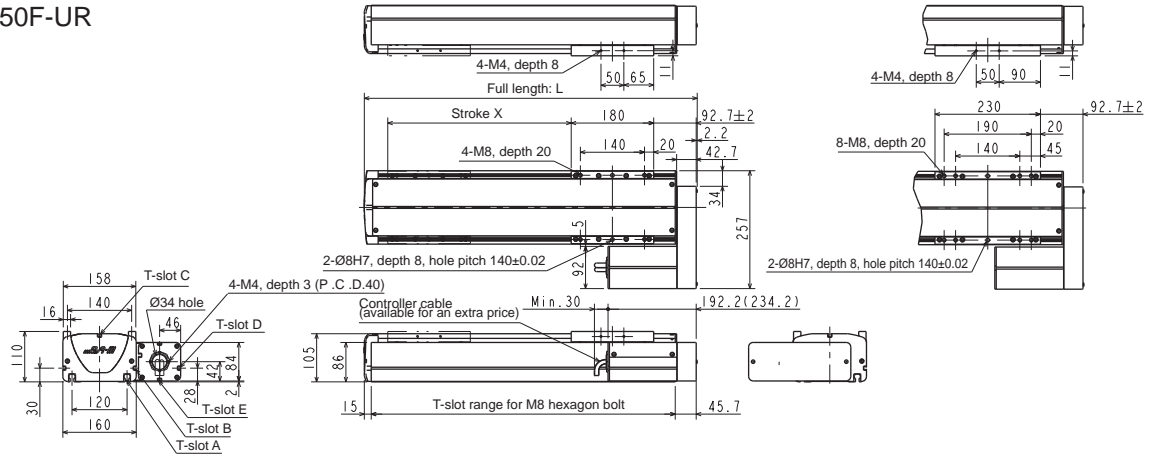

BE50F-UL

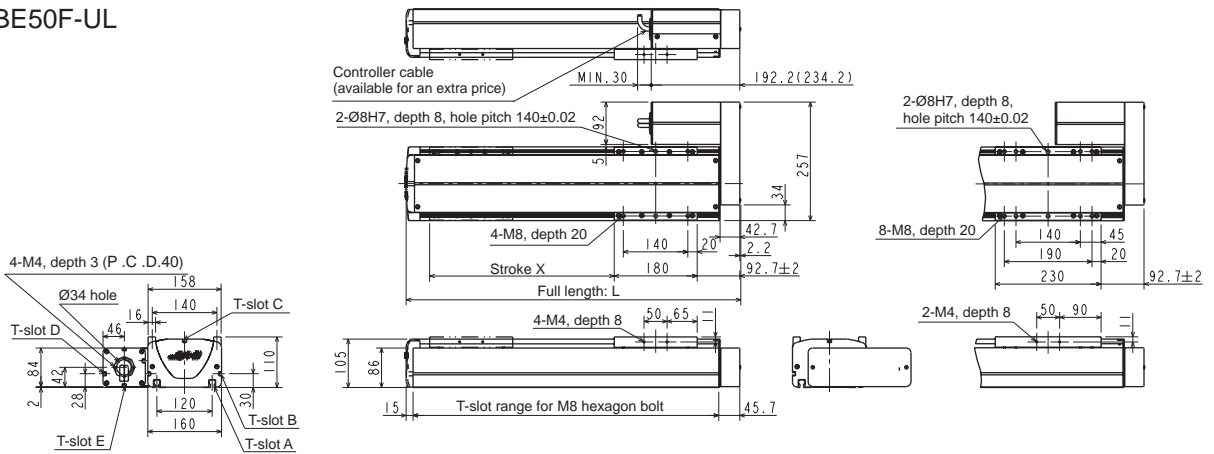

BE50F-UU

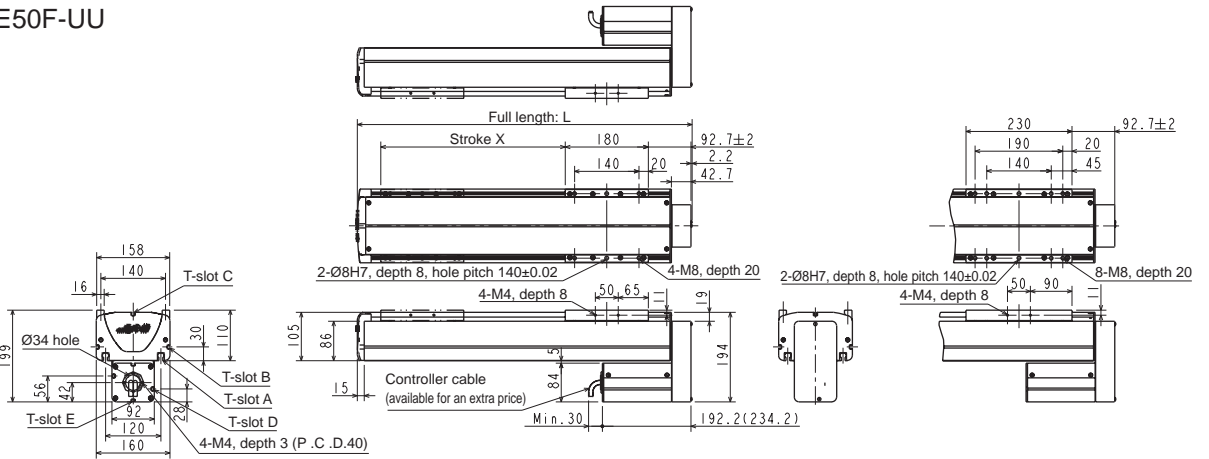

Common to BE50F-UR, UL and UU.

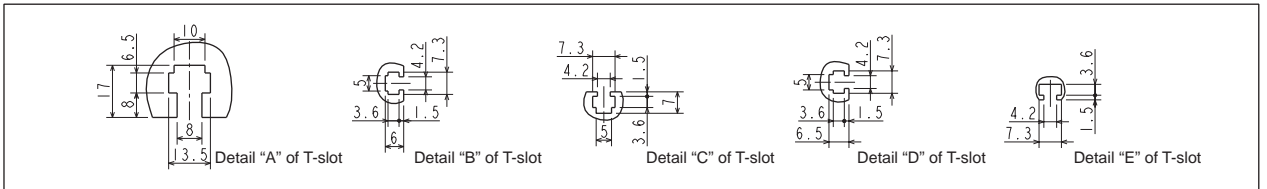

Mounted motor axis

Medium slider stroke (mm)	200	300	400	500	600	700	800	900	1000	1100	1200	1300	1400	1500
Full length L (mm)	525.9	625.9	725.9	825.9	925.9	1025.9	1125.9	1225.9	1325.9	1425.9	1525.9	1625.9	1725.9	1825.9
Weight (kg)	12.3 (12.9)	14.2 (14.8)	16.1 (16.7)	18.0 (18.6)	19.9 (20.5)	21.8 (22.4)	23.7 (24.3)	25.6 (26.2)	27.5 (28.1)	29.4 (30.0)	31.3 (31.9)	33.2 (33.8)	35.1 (35.7)	37.0 (37.6)

* Values in parentheses are for the axis with brake.

Long slider stroke (mm)	250	350	450	550	650	750	850	950	1050	1150	1250	1350	1450
Full length L (mm)	625.9	725.9	825.9	925.9	1025.9	1125.9	1225.9	1325.9	1425.9	1525.9	1625.9	1725.9	1825.9
Weight (kg)	14.8 (15.4)	16.7 (17.3)	18.6 (19.2)	20.5 (21.1)	22.4 (23.0)	24.3 (24.9)	26.2 (26.8)	28.1 (28.7)	30.0 (30.6)	31.9 (32.5)	33.8 (34.4)	35.7 (36.3)	37.6 (38.2)

* Values in parentheses are for the axis with brake.

[Set designation]

BA3 – 50G – ST – M 20 N – 40 – 1 3

Axis structure	Type of slider	Lead	Brake	Stroke	Controller (CA25-M40)	Cable length
ST : Straight axis UR : Right side mounted motor axis UL : Left side mounted motor axis UU : Bottom side mounted motor axis	M : Medium slider L : Long slider	05 : 5mm 10 : 10mm 20 : 20mm	N : Without brake B : With brake	Type designation	0 : None 1 : NPN output specifications Other : See page 19	3 : 3m 9 : 9m 5 : 5m B : 11m 7 : 7m D : 13m

[Specifications]

Motor	200 W AC servo motor (absolute)								
Drive system	Ground ball screw (C7), thread outer diameter 20 mm								
Stroke (mm) (in increments of 100 mm)	Medium slider	200~600	700, 800	900, 1000	1100, 1200	1300	1400	1500	1600
	Type designation	20~60	70, 80	90, A0	B0, C0	D0	E0	F0	G0
	Long slider	250~550	650, 750	850, 950	1050, 1150	1250	1350	1450	1550
	Type designation	25~55	65, 75	85, 95	A5, B5	C5	D5	E5	F5
Maximum speed (mm/s) Values in <> signify the acceleration/deceleration time in seconds when the maximum payload is loaded.	Lead 20 mm	1200<0.36>	1100<0.33>	1000<0.30>	700<0.21>	500<0.15>	400<0.12>	300<0.10>	300<0.10>
	Lead 10 mm	600<0.36>	550<0.33>	500<0.30>	350<0.21>	250<0.15>	200<0.12>	150<0.10>	150<0.10>
	Lead 5 mm	300<0.36>	280<0.33>	250<0.30>	180<0.21>	130<0.15>	100<0.12>	80<0.10>	80<0.10>
Maximum payload (kg)	Lead 20 mm	Horizontal transfer: 100			Vertical transfer: 25				
	Lead 10 mm	Horizontal transfer: 150			Vertical transfer: 50				
	Lead 5 mm	Horizontal transfer: 150			Vertical transfer: 60				
Positioning repeatability (mm)	±0.01								
Resolution (mm)	0.01								
Allowable static load moment (N·m)	Medium slider	MR : 2080	MP : 2160	MY : 1820	Long slider	MR : 2080	MP : 3150	MY : 2640	
Brake	Brake voltage DC24 V								
Master controller	CA25-M40								

- Notes:
- * When using the axis as a vertical axis, select the type with brake.
 - * The maximum payload signifies a load exerted on top of the slider. Also refers to the description on the dynamic load moment appearing later in this document.
 - * The values in parentheses under "Maximum payload" are applicable when a regenerative discharge unit ABSU-4000 is equipped.
 - * The acceleration/deceleration time represents the time until the axis reaches a programmed speed.

[Axis designation]

BE50G – ST – M 20 N – 40

Axis structure	Type of slider	Lead	Brake	Stroke
ST : Straight axis UR : Right side mounted motor axis UL : Left side mounted motor axis UU : Bottom side mounted motor axis	M : Medium slider L : Long slider	05 : 5mm 10 : 10mm 20 : 20mm	N : Without brake B : With brake	Type designation

[Dimensions]

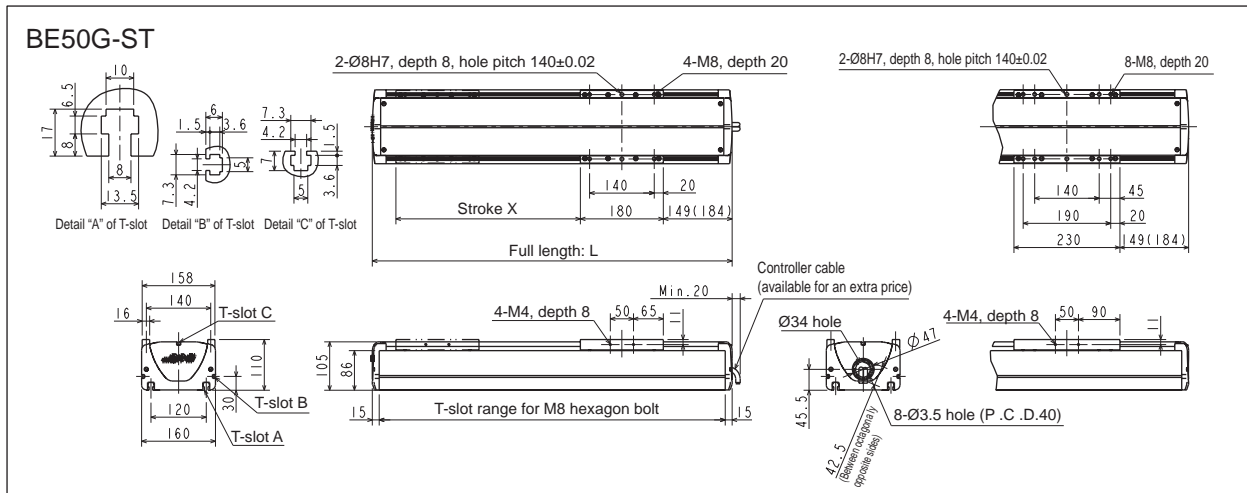

Straight axis

Medium slider stroke (mm)	200	300	400	500	600	700	800	900	1000	1100	1200	1300	1400	1500	1600
Full length L (mm)	580 (615)	680 (715)	780 (815)	880 (915)	980 (1015)	1080 (1115)	1180 (1215)	1280 (1315)	1380 (1415)	1480 (1515)	1580 (1615)	1680 (1715)	1780 (1815)	1880 (1915)	1980 (2015)
Weight (kg)	16.3 (17.2)	18.2 (19.1)	20.1 (21.0)	22.0 (22.9)	23.9 (24.8)	25.8 (26.7)	27.7 (28.6)	29.6 (30.5)	31.5 (32.4)	33.4 (34.3)	35.3 (36.2)	37.2 (38.1)	39.1 (40.0)	41.0 (41.9)	42.9 (43.8)

* Values in parentheses are for the axis with brake.

Long slider stroke (mm)	250	350	450	550	650	750	850	950	1050	1150	1250	1350	1450	1550
Full length L (mm)	680 (715)	780 (815)	880 (915)	980 (1015)	1080 (1115)	1180 (1215)	1280 (1315)	1380 (1415)	1480 (1515)	1580 (1615)	1680 (1715)	1780 (1815)	1880 (1915)	1980 (2015)
Weight (kg)	18.8 (19.7)	20.7 (21.6)	22.6 (23.5)	24.5 (25.4)	26.4 (27.3)	28.3 (29.2)	30.2 (31.1)	32.1 (33.0)	34.0 (34.9)	35.9 (36.8)	37.8 (38.7)	39.7 (40.6)	41.6 (42.5)	43.5 (44.4)

* Values in parentheses are for the axis with brake.

BE50G-UR

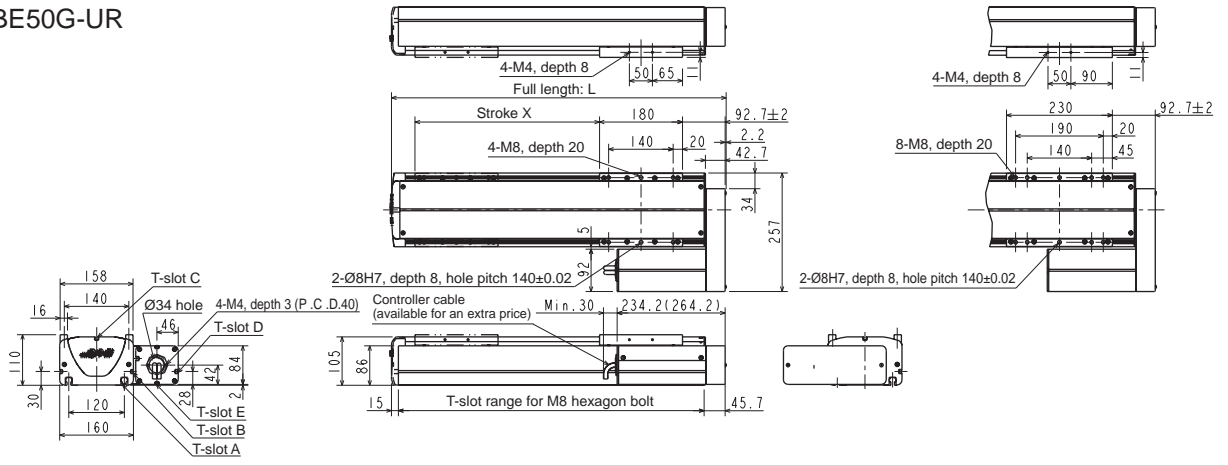

BE50G-UL

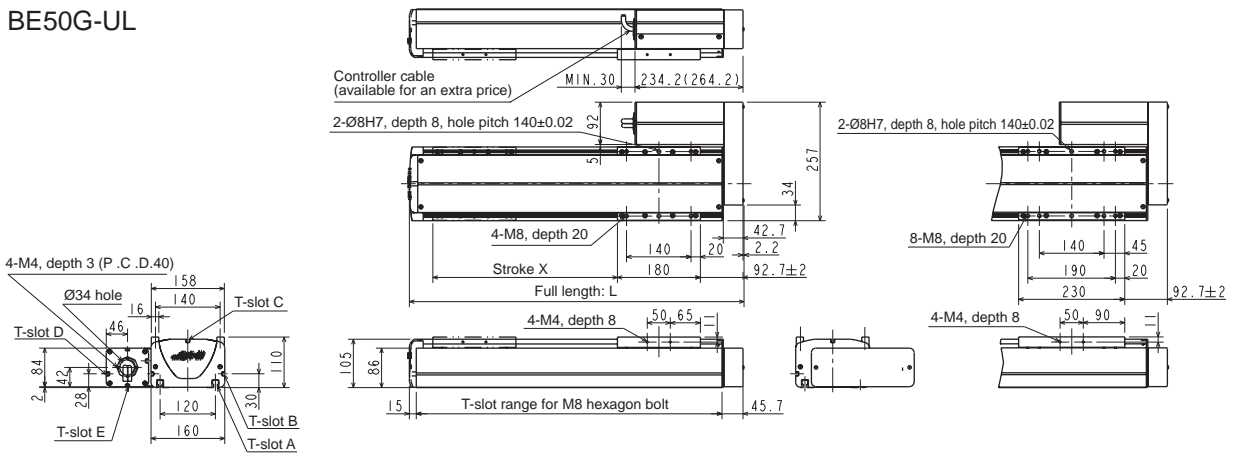

BE50G-UU

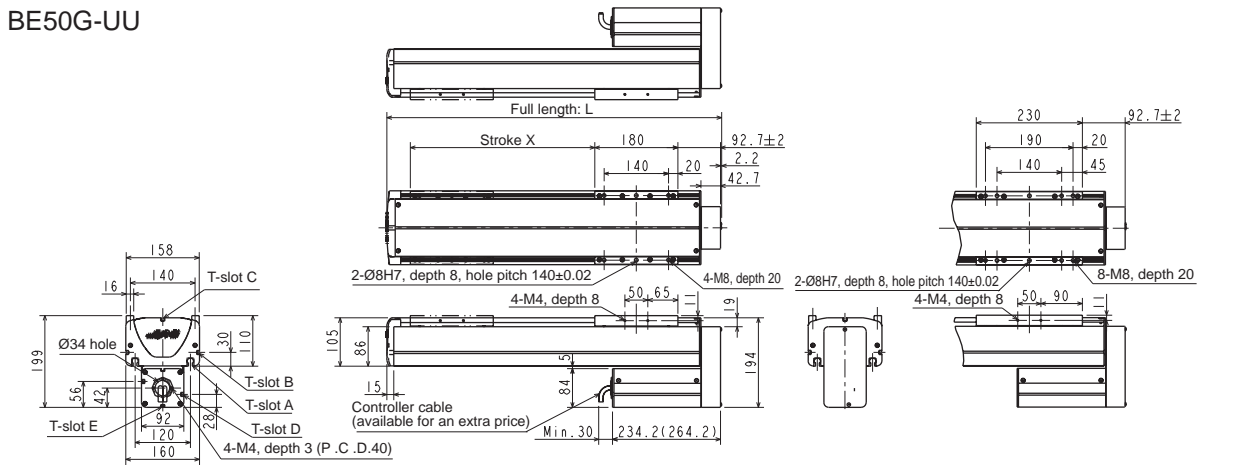

Common to BE50G-UR, UL and UU.

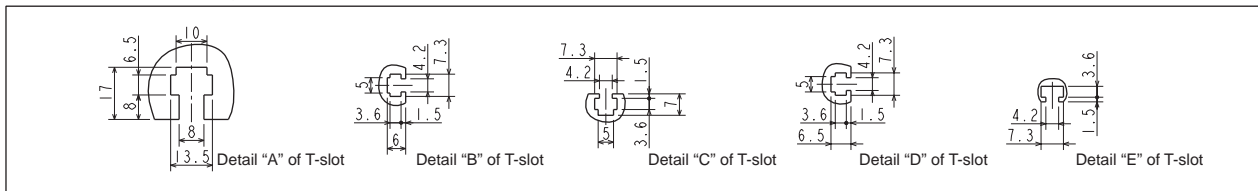

Mounted motor axis

Medium slider stroke (mm)	200	300	400	500	600	700	800	900	1000	1100	1200	1300	1400	1500
Full length L (mm)	525.9	625.9	725.9	825.9	925.9	1025.9	1125.9	1225.9	1325.9	1425.9	1525.9	1625.9	1725.9	1825.9
Weight (kg)	12.8 (13.4)	14.7 (15.3)	16.6 (17.2)	18.5 (19.1)	20.4 (21.0)	22.3 (22.9)	24.2 (24.8)	26.1 (26.7)	28.0 (28.6)	29.9 (30.5)	31.8 (32.4)	33.7 (34.3)	35.6 (36.2)	37.5 (38.1)

* Values in parentheses are for the axis with brake.

Long slider stroke (mm)	250	350	450	550	650	750	850	950	1050	1150	1250	1350	1450
Full length L (mm)	625.9	725.9	825.9	925.9	1025.9	1125.9	1225.9	1325.9	1425.9	1525.9	1625.9	1725.9	1825.9
Weight (kg)	15.3 (15.9)	17.2 (17.8)	19.1 (19.7)	21.0 (21.6)	22.9 (23.5)	24.8 (25.4)	26.7 (27.3)	28.6 (29.2)	30.5 (31.1)	32.4 (33.0)	34.3 (34.9)	36.2 (36.8)	38.1 (38.7)

* Values in parentheses are for the axis with brake.

[Set designation]

BA3 – 60G – ST – M 20 N – 40 – 1 3

Type of slider M : Medium slider L : Long slider	Lead 10 : 10mm 20 : 20mm 40 : 40mm	Brake N : Without brake B : With brake	Stroke Type designation 0 : None 1 : NPN output specifications Other : See page 19	Controller (CA25-M40) 3 : 3m 5 : 5m 7 : 7m	Cable length 9 : 9m 11 : 11m 13 : 13m
--	---	--	--	---	--

[Specifications]

Motor	400 W AC servo motor (absolute)								
Drive system	Ball screw (nut rotation type), thread outer diameter 20 mm								
Stroke (mm) (in increments of 100 mm)	Medium slider	200 ~ 700	800	900	1000	1100	1200	1300	1400,1500
	Type designation	20 ~ 70	80	90	A0	B0	C0	D0	E0,F0
Maximum speed (mm/s) Values in <> signify the acceleration/deceleration time in seconds when the maximum payload is loaded.	Long slider	150 ~ 650	750	850	950	1050	1150	1250	1350,1450
	Type designation	15 ~ 65	75	85	95	A5	B5	C5	D5,E5
Maximum payload (kg)	Lead 20 mm	Horizontal transfer: 100			Vertical transfer: 25				
	Lead 10 mm	Horizontal transfer: 150			Vertical transfer: 50				
Positioning repeatability (mm)	± 0.01								
Resolution (mm)	0.01								
Allowable static load moment (N·m)	Medium slider MR : 2700 MP : 3000 MY : 2250 Long slider MR : 2700 MP : 4750 MY : 3450								
Brake	Brake voltage DC24 V								
Master controller	CA25-M40								

- Notes:
- * When using the axis as a vertical axis, select the type with brake.
 - * The maximum payload signifies a load exerted on top of the slider. Also refers to the description on the dynamic load moment appearing later in this document.
 - * The values in parentheses under "Maximum payload" are applicable when a regenerative discharge unit ABSU-4000 is equipped.
 - * The acceleration/deceleration time represents the time until the axis reaches a programmed speed.

Ball-screw driven

[Axis designation]

BE60G – ST – M 20 N – 40

Type of slider M : Medium slider L : Long slider	Lead 10 : 10mm 20 : 20mm 40 : 40mm	Brake N : Without brake B : With brake	Stroke Type designation
--	---	--	----------------------------

[Dimensions]

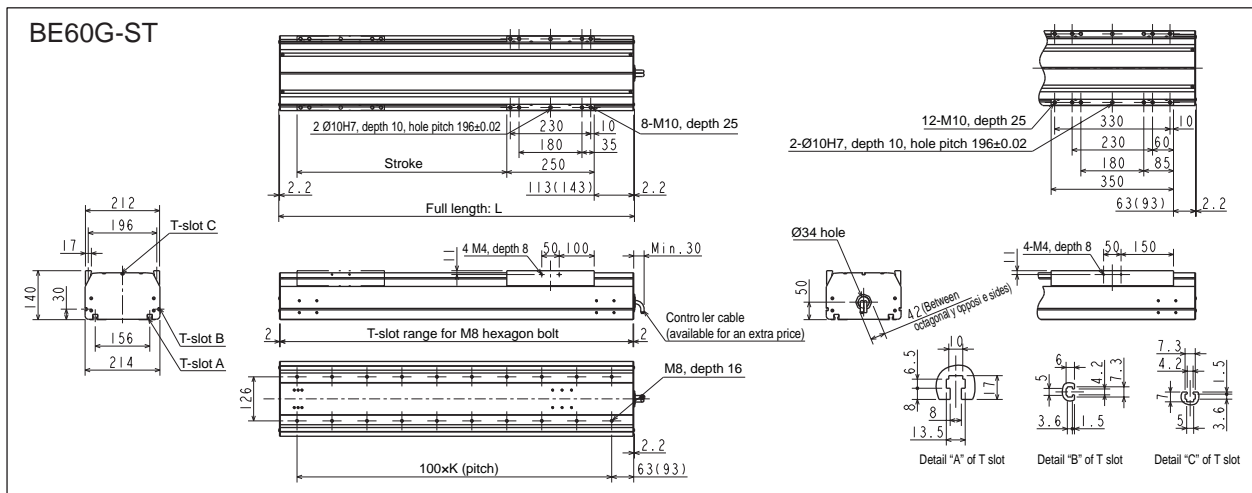

Straight axis

Medium slider stroke (mm)	200	300	400	500	600	700	800	900	1000	1100	1200	1300	1400	1500
Full length L (mm)	617.4 (647.4)	717.4 (747.4)	817.4 (847.4)	917.4 (947.4)	1017.4 (1047.4)	1117.4 (1147.4)	1217.4 (1247.4)	1317.4 (1347.4)	1417.4 (1447.4)	1517.4 (1547.4)	1617.4 (1647.4)	1717.4 (1747.4)	1817.4 (1847.4)	1917.4 (1947.4)
Weight (kg)	24.0 (25.2)	26.8 (28.0)	29.5 (30.7)	32.3 (33.5)	35.0 (36.2)	37.8 (39.0)	40.5 (41.7)	43.3 (44.5)	46.0 (47.2)	48.8 (50.0)	51.5 (52.7)	54.3 (55.5)	57.0 (58.2)	59.8 (61.0)

* Values in parentheses are for the axis with brake.

Long slider stroke (mm)	150	250	350	450	550	650	750	850	950	1050	1150	1250	1350	1450
Full length L (mm)	617.4 (647.4)	717.4 (747.4)	817.4 (847.4)	917.4 (947.4)	1017.4 (1047.4)	1117.4 (1147.4)	1217.4 (1247.4)	1317.4 (1347.4)	1417.4 (1447.4)	1517.4 (1547.4)	1617.4 (1647.4)	1717.4 (1747.4)	1817.4 (1847.4)	1917.4 (1947.4)
Weight (kg)	25.5 (26.7)	28.3 (29.5)	31.0 (32.2)	33.8 (35.0)	36.5 (37.7)	39.3 (40.5)	42.0 (43.2)	44.8 (46.0)	47.5 (48.7)	50.3 (51.5)	53.0 (54.2)	55.8 (57.0)	58.5 (59.7)	61.3 (62.5)

* Values in parentheses are for the axis with brake.

[Set designation]

BA3 – 60J – ST – M 20 N – 40 – 13

Type of slider	Lead	Brake	Stroke	Controller (CA25-M80)	Cable length
M : Medium slider L : Long slider	10 : 10mm 20 : 20mm 50 : 50mm	N : Without brake B : With brake	Type designation	0 : None 1 : NPN output specifications Other : See page 19	3 : 3m 9 : 9m 5 : 5m B : 11m 7 : 7m D : 13m

[Specifications]

Motor	750 W AC servo motor (absolute)						
Drive system	Ground ball screw (C7), thread outer diameter 25 mm						
Stroke (mm) (in increments of 100 mm)	Medium slider	200 ~ 1000	1100	1200	1300	1400,1500	1600,1700
	Type designation	20 ~ A0	B0	C0	D0	E0,F0	G0,H0
Maximum speed (mm/s) Values in < > signify the acceleration/deceleration time in seconds when the maximum payload is loaded.	Long slider	150 ~ 950	1050	1150	1250	1350,1450	1550,1650
	Type designation	15 ~ 95	A5	B5	C5	D5,E5	F5,G5
Maximum payload (kg)	Lead 50 mm	2300<0.27>		1800<0.21>	1500<0.18>	1300<0.15>	1000<0.12>
	Lead 20 mm	900<0.27>		700<0.21>	600<0.18>	500<0.15>	400<0.12>
	Lead 10 mm	450<0.27>		350<0.21>	300<0.18>	250<0.15>	200<0.12>
Positioning repeatability (mm)	Horizontal transfer: 50 Vertical transfer: -						
	Horizontal transfer: 200 Vertical transfer: 50						
	Horizontal transfer: 250 Vertical transfer: 100						
Resolution (mm)	± 0.01						
Allowable static load moment (N·m)	0.01						
Brake	Medium slider MR : 3500 MP : 4000 MY : 3000 Long slider MR : 3500 MP : 6200 MY : 4750						
Master controller	CA25-M80						

- Notes:
- * When using the axis as a vertical axis, select the type with brake.
 - * The maximum payload signifies a load exerted on top of the slider. Also refers to the description on the dynamic load moment appearing later in this document.
 - * The values in parentheses under "Maximum payload" are applicable when a regenerative discharge unit ABSU-8000 is equipped.
 - * The acceleration/deceleration time represents the time until the axis reaches a programmed speed.

[Axis designation]

BE60J – ST – M 20 N – 40

Type of slider	Lead	Brake	Stroke
M : Medium slider L : Long slider	10 : 10mm 20 : 20mm 50 : 50mm	N : Without brake B : With brake	Type designation

[Dimensions]

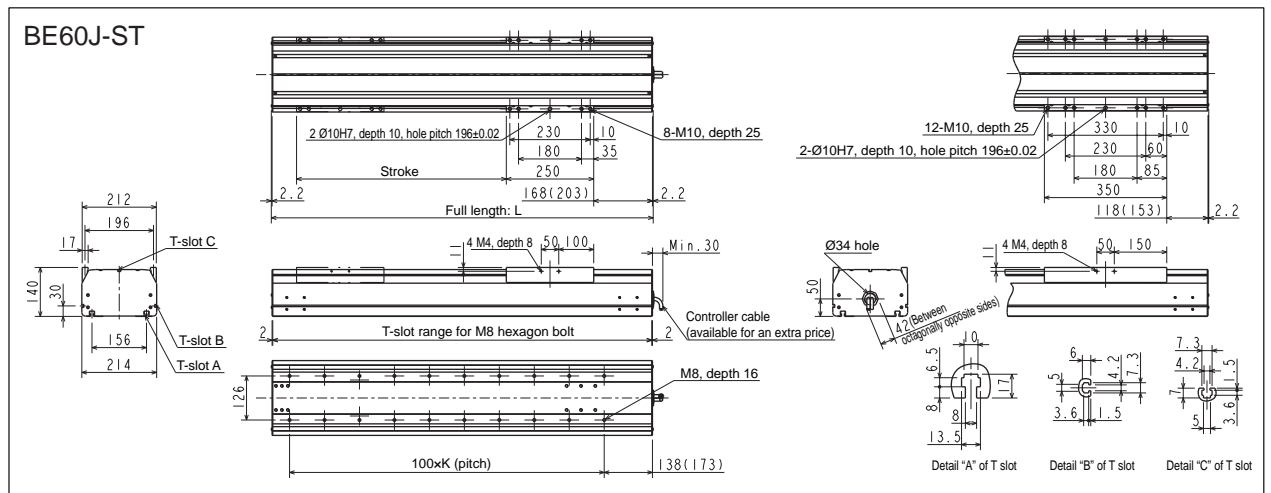

Straight axis

Medium slider stroke (mm)	200	300	400	500	600	700	800	900	1000	1100	1200	1300	1400	1500	1600	1700
Full length L (mm)	692.4 (727.4)	792.4 (827.4)	892.4 (927.4)	992.4 (1027.4)	1092.4 (1127.4)	1192.4 (1227.4)	1292.4 (1327.4)	1392.4 (1427.4)	1492.4 (1527.4)	1592.4 (1627.4)	1692.4 (1727.4)	1792.4 (1827.4)	1892.4 (1927.4)	1992.4 (2027.4)	2092.4 (2127.4)	2192.4 (2227.4)
K	5	6	7	8	9	10	11	12	13	14	15	16	17	18	19	20
Weight (kg)	37.2 (38.8)	40.0 (41.6)	42.7 (44.3)	45.5 (47.1)	48.2 (49.8)	51.0 (52.6)	53.7 (55.3)	56.5 (58.1)	59.2 (60.8)	62.0 (63.6)	64.7 (66.3)	67.5 (69.1)	70.2 (71.8)	73.0 (74.6)	75.7 (77.3)	78.5 (80.1)

* Values in parentheses are for the axis with brake.

Long slider stroke (mm)	150	250	350	450	550	650	750	850	950	1050	1150	1250	1350	1450	1550	1650
Full length L (mm)	692.4 (727.4)	792.4 (827.4)	892.4 (927.4)	992.4 (1027.4)	1092.4 (1127.4)	1192.4 (1227.4)	1292.4 (1327.4)	1392.4 (1427.4)	1492.4 (1527.4)	1592.4 (1627.4)	1692.4 (1727.4)	1792.4 (1827.4)	1892.4 (1927.4)	1992.4 (2027.4)	2092.4 (2127.4)	2192.4 (2227.4)
K	5	6	7	8	9	10	11	12	13	14	15	16	17	18	19	20
Weight (kg)	38.7 (40.3)	41.5 (43.1)	44.2 (45.8)	47.0 (48.6)	49.7 (51.3)	52.5 (54.1)	55.2 (56.8)	58.0 (59.6)	60.7 (62.3)	63.5 (65.1)	66.2 (67.8)	69.0 (70.6)	71.7 (73.3)	74.5 (76.1)	77.2 (78.8)	80.0 (81.6)

* Values in parentheses are for the axis with brake.

[Set designation]

BA3 - 10E - BT - M 21 N - 40 - 1 3

Motor set direction BT : Facing up BR : Facing right BL : Facing left BU : Facing down	Type of slider S : Short slider M : Medium slider	Lead 21 : 21mm	Brake N : Without brake	Stroke Type designation	Controller (CA25-M10) 0 : None 1 : NPN output specifications Other : See page 19	Cable length 3 : 3m 9 : 9m 5 : 5m B : 11m 7 : 7m D : 13m
--	---	-------------------	----------------------------	----------------------------	---	---

[Specifications]

Motor	100 W AC servo motor (absolute)																	
Drive system	Timing belt																	
Ball screw lead (mm)	21																	
Stroke (mm) (in increments of 100 mm)	Short slider	150~950	1050	1150	1250	1350	1450	1550	1650	1750	1850	1950	2050	2150	2250	2350	2450	2550
	Type designation	15~95	A5	B5	C5	D5	E5	F5	G5	H5	J5	K5	L5	M5	N5	P5	Q5	R5
	Medium slider	100~900	1000	1100	1200	1300	1400	1500	1600	1700	1800	1900	2000	2100	2200	2300	2400	2500
	Type designation	10~90	A0	B0	C0	D0	E0	F0	G0	H0	J0	K0	L0	M0	N0	P0	Q0	R0
Maximum speed (mm/s)	1000																	
Maximum payload (kg) Acceleration/deceleration time: 0.3 sec or over	Horizontal transfer: 15																	
Positioning repeatability (mm)	± 0.04																	
Resolution (mm)	0.01																	
Allowable static load moment (N·m)	Short slider MR : 49 MP : 14 MY : 13				Medium slider MR : 59 MP : 59 MY : 54													
Master controller	CA25-M10																	

Notes: * The maximum payload signifies a load exerted on top of the slider. Also refers to the description on the dynamic load moment appearing later in this document.

* The acceleration/deceleration time represents the time until the axis reaches a programmed speed.

Timing Belt Driven

[Axis designation]

BE10E - BT - M 21 N - 40

Motor set direction BT : Facing up BR : Facing right BL : Facing left BU : Facing down	Type of slider S : Short slider M : Medium slider	Lead 21 : 21mm	Brake N : Without brake	Stroke Type designation
--	---	-------------------	----------------------------	----------------------------

[Dimensions]

BE10E-BT

[Note 1] The values in parentheses are applicable when the stroke is 1,100 mm or over.

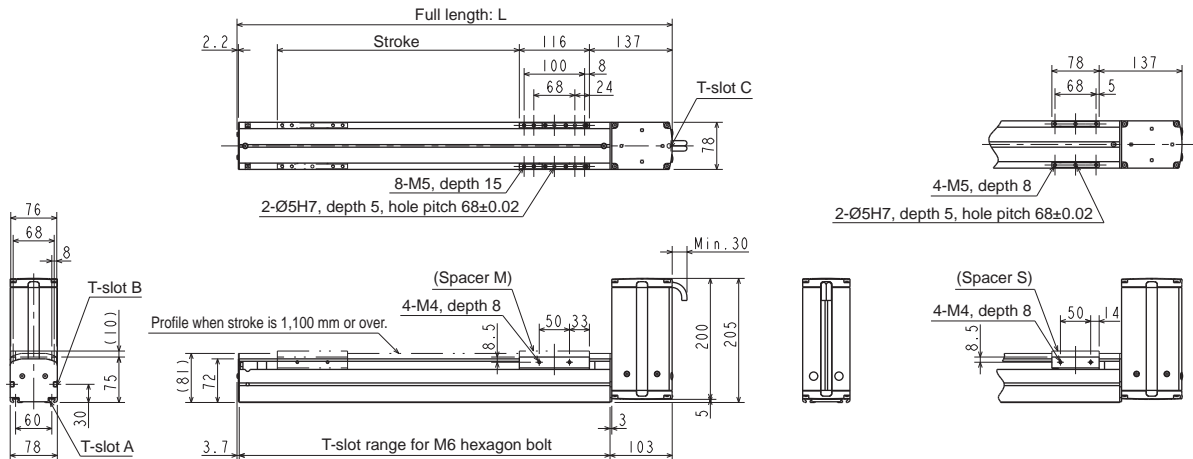

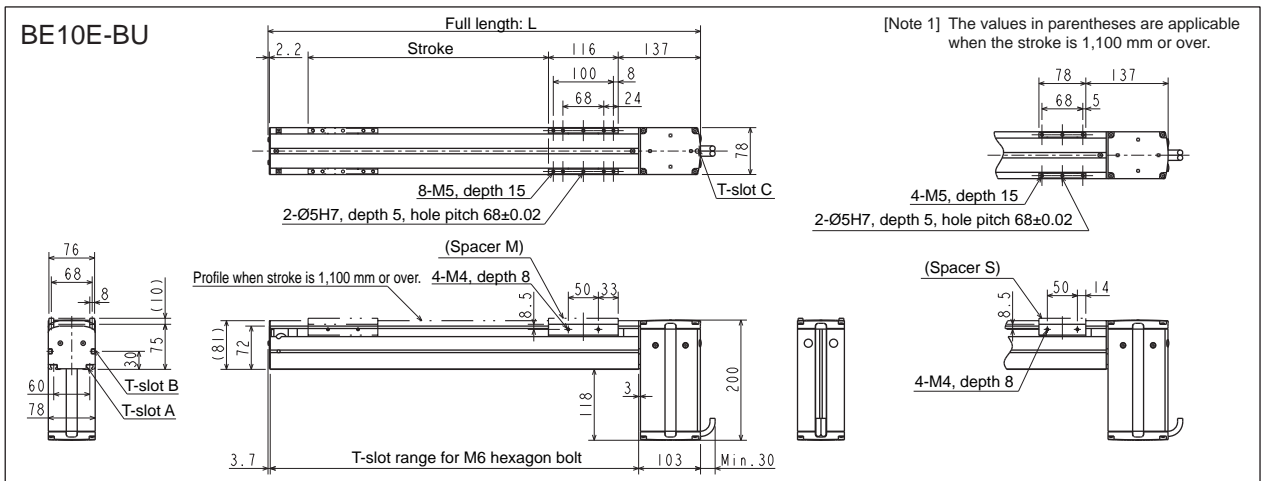
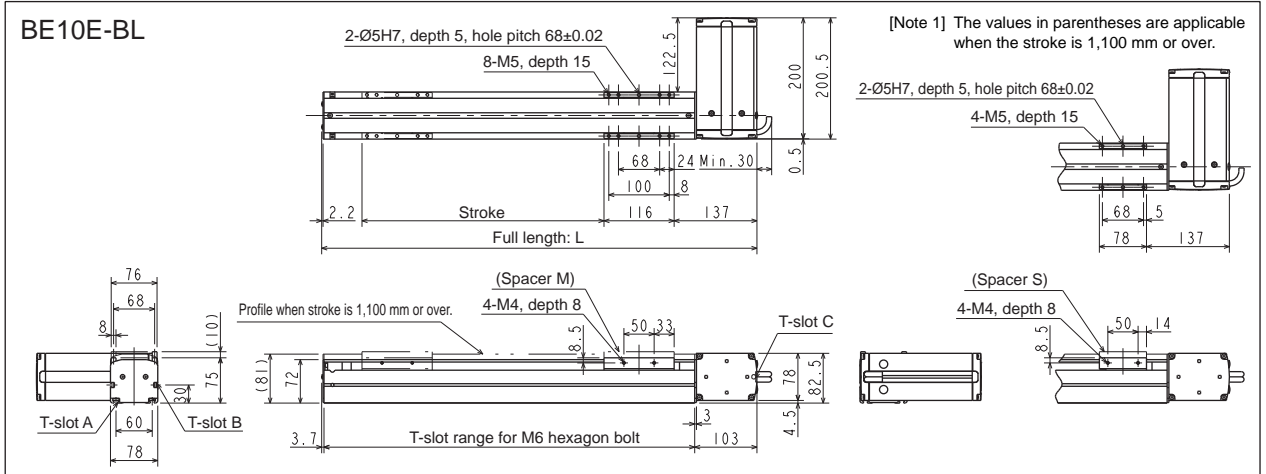
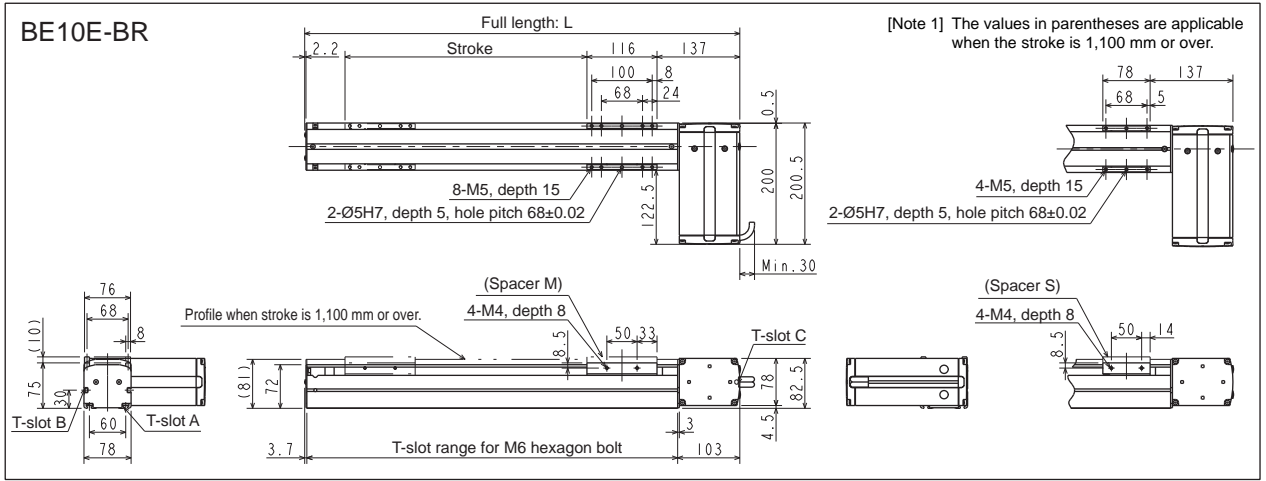

Common to BE10E-BT, BR, BL and BU.

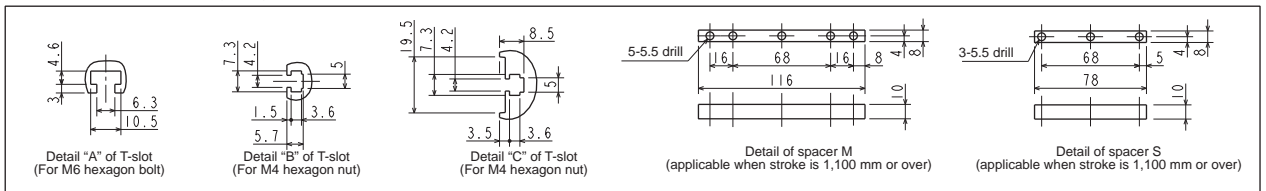

Medium slider Common to BE10E-BT, BR, BL and BU.

Stroke X (mm)	100	200	300	400	500	600	700	800	900	1000	1100	1200	1300	1400	1500	1600	1700	1800	1900	2000	2100	2200	2300	2400	2500
Full length L (mm)	419.7	519.7	619.7	719.7	819.7	919.7	1019.7	1119.7	1219.7	1319.7	1419.7	1519.7	1619.7	1719.7	1819.7	1919.7	2019.7	2119.7	2219.7	2319.7	2419.7	2519.7	2619.7	2719.7	2819.7
Weight (kg)	4.9	5.6	6.2	6.9	7.6	8.2	8.9	9.6	10.2	10.9	12.1	12.8	13.5	14.2	14.9	15.6	16.3	17.0	17.8	18.5	19.2	19.9	20.6	21.3	22.0

Short slider Common to BE10E-BT, BR, BL and BU.

Stroke X (mm)	150	250	350	450	550	650	750	850	950	1050	1150	1250	1350	1450	1550	1650	1750	1850	1950	2050	2150	2250	2350	2450	2550
Full length L (mm)	419.7	519.7	619.7	719.7	819.7	919.7	1019.7	1119.7	1219.7	1319.7	1419.7	1519.7	1619.7	1719.7	1819.7	1919.7	2019.7	2119.7	2219.7	2319.7	2419.7	2519.7	2619.7	2719.7	2819.7
Weight (kg)	4.5	5.2	5.9	6.5	7.2	7.9	8.5	9.2	9.8	10.5	11.7	12.4	13.1	13.8	14.5	15.2	15.9	16.6	17.3	18.0	18.7	19.4	20.1	20.8	21.5

[Set designation]

BA3 - 10F - BT - M 21 N - 40 - 13

Motor set direction BT : Facing up BR : Facing right BL : Facing left BU : Facing down	Type of slider S : Short slider M : Medium slider	Lead 21 : 21mm 42 : 42mm	Brake N : Without brake	Stroke Type designation	Controller (CA25-M10) 0 : None 1 : NPN output specifications Other : See page 19	Cable length 3 : 3m 9 : 9m 5 : 5m B : 11m 7 : 7m D : 13m
--	---	--------------------------------	----------------------------	----------------------------	---	---

[Specifications]

Motor	200 W AC servo motor (absolute)																	
Drive system	Timing belt																	
Ball screw lead (mm)	21, 42																	
Stroke (mm) (in increments of 100 mm)	Short slider	150~950	1050	1150	1250	1350	1450	1550	1650	1750	1850	1950	2050	2150	2250	2350	2450	2550
	Type designation	15~95	A5	B5	C5	D5	E5	F5	G5	H5	J5	K5	L5	M5	N5	P5	Q5	R5
Maximum speed (mm/s)	Lead 21	1000																
	Lead 42	2000																
Maximum payload (kg)	Lead 21	Horizontal transfer: 20, acceleration/deceleration time: 0.3 sec. or over																
	Lead 42	Horizontal transfer: 10, acceleration/deceleration time: 0.5 sec. or over																
Positioning repeatability (mm)	± 0.04																	
Resolution (mm)	0.01																	
Allowable static load moment (N·m)	Short slider MR : 49 MP : 14 MY : 13 Medium slider MR : 59 MP : 59 MY : 54																	
Master controller	CA25-M10																	

Notes: * The maximum payload signifies a load exerted on top of the slider. Also refers to the description on the dynamic load moment appearing later in this document.

* The acceleration/deceleration time represents the time until the axis reaches a programmed speed.

Timing Belt Driven

[Axis designation]

BE10F - BT - M 21 N - 40

Motor set direction BT : Facing up BR : Facing right BL : Facing left BU : Facing down	Type of slider S : Short slider M : Medium slider	Lead 21 : 21mm 42 : 42mm	Brake N : Without brake	Stroke Type designation
--	---	--------------------------------	----------------------------	----------------------------

[Dimensions]

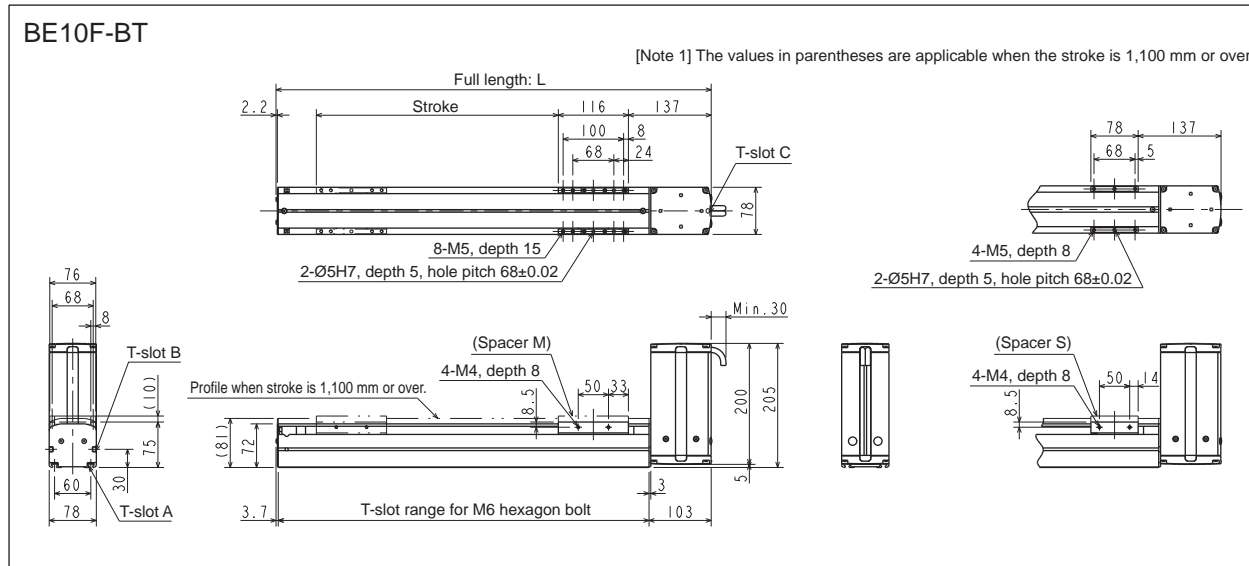

Common to BE10F-BT, BR, BL and BU.

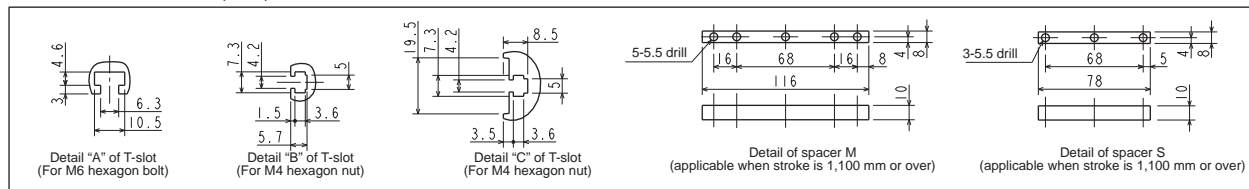

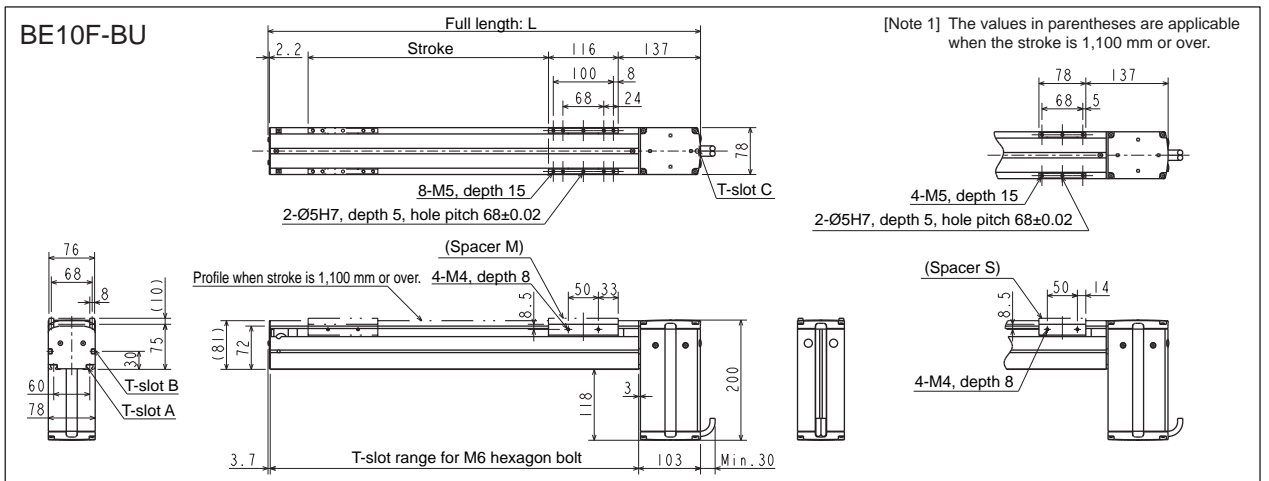
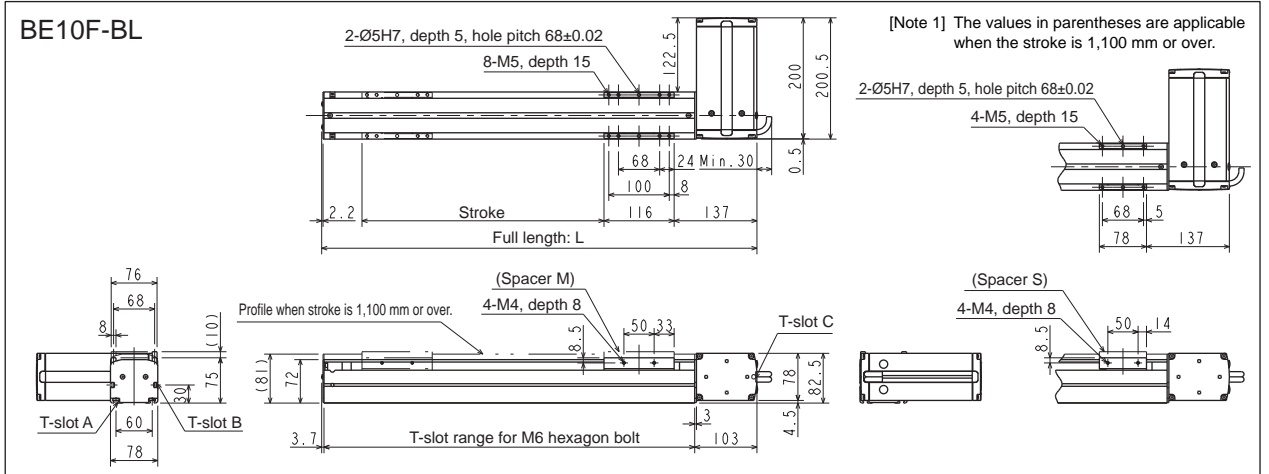
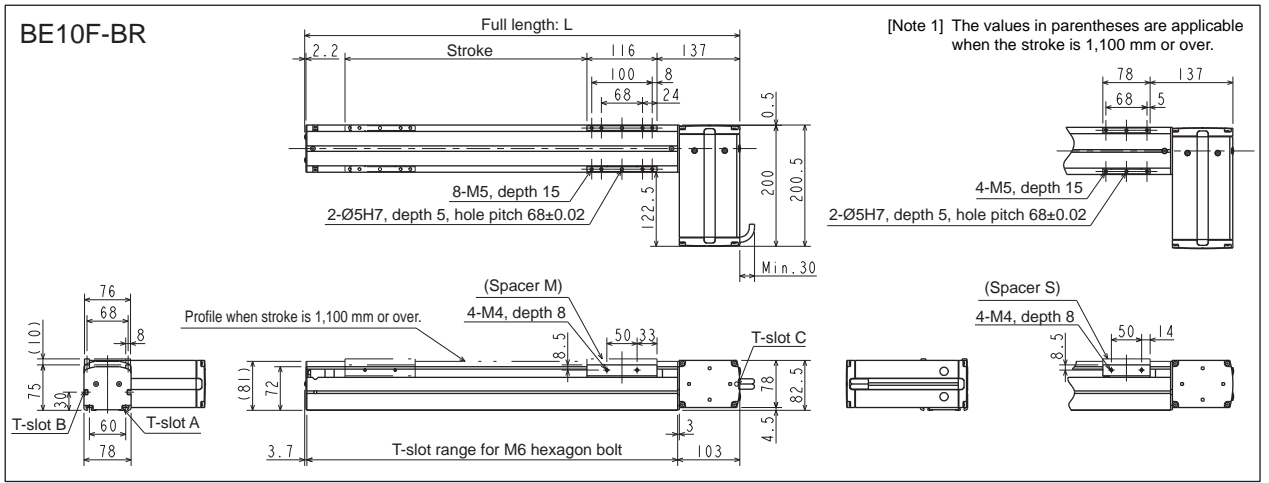

Medium slider Lead 21mm common to BE10F-BT, BR, BL and BU.

Stroke X (mm)	100	200	300	400	500	600	700	800	900	1000	1100	1300	1400	1500	1600	1700	1800	1900	2000	2100	2200	2300	2400	2500	
Full length L (mm)	419.7	519.7	619.7	719.7	819.7	919.7	1019.7	1119.7	1219.7	1319.7	1419.7	1519.7	1619.7	1719.7	1819.7	1919.7	2019.7	2119.7	2219.7	2319.7	2419.7	2519.7	2619.7	2719.7	2819.7
Weight (kg)	5.5	6.2	6.8	7.5	8.2	8.8	9.5	10.2	10.8	11.5	12.7	13.4	14.1	14.8	15.5	16.2	16.9	17.6	18.4	19.1	19.8	20.5	21.2	21.9	22.6

Short slider Lead 21mm common to BE10F-BT, BR, BL and BU.

Stroke X (mm)	150	250	350	450	550	650	750	850	950	1050	1150	1250	1350	1450	1550	1650	1750	1850	1950	2050	2150	2250	2350	2450	2550
Full length L (mm)	419.7	519.7	619.7	719.7	819.7	919.7	1019.7	1119.7	1219.7	1319.7	1419.7	1519.7	1619.7	1719.7	1819.7	1919.7	2019.7	2119.7	2219.7	2319.7	2419.7	2519.7	2619.7	2719.7	2819.7
Weight (kg)	5.1	5.8	6.5	7.1	7.8	8.5	9.1	9.8	10.4	11.1	12.3	13.0	13.7	14.4	15.1	15.8	16.5	17.2	17.9	18.6	19.3	20.0	20.7	21.4	22.1

Medium slider Lead 42mm common to BE10F-BT, BR, BL and BU.

Stroke X (mm)	100	200	300	400	500	600	700	800	900	1000	1100	1200	1300	1400	1500	1600	1700	1800	1900	2000	2100	2200	2300	2400	2500
Full length L (mm)	419.7	519.7	619.7	719.7	819.7	919.7	1019.7	1119.7	1219.7	1319.7	1419.7	1519.7	1619.7	1719.7	1819.7	1919.7	2019.7	2119.7	2219.7	2319.7	2419.7	2519.7	2619.7	2719.7	2819.7
Weight (kg)	4.9	5.6	6.2	6.9	7.6	8.2	8.9	9.6	10.2	10.9	12.1	12.8	13.5	14.2	14.9	15.6	16.3	17.0	17.8	18.5	19.2	19.9	20.6	21.3	22.0

Short slider Lead 42mm common to BE10F-BT, BR, BL and BU.

Stroke X (mm)	150	250	350	450	550	650	750	850	950	1050	1150	1250	1350	1450	1550	1650	1750	1850	1950	2050	2150	2250	2350	2450	2550
Full length L (mm)	419.7	519.7	619.7	719.7	819.7	919.7	1019.7	1119.7	1219.7	1319.7	1419.7	1519.7	1619.7	1719.7	1819.7	1919.7	2019.7	2119.7	2219.7	2319.7	2419.7	2519.7	2619.7	2719.7	2819.7
Weight (kg)	4.5	5.2	5.9	6.5	7.2	7.9	8.5	9.2	9.8	10.5	11.7	12.4	13.1	13.8	14.5	15.2	15.9	16.6	17.3	18.0	18.7	19.4	20.1	20.8	21.5

[Set designation]

BA3 – 30E – BT – M 21 N – 40 – 1 3

Motor set direction	Type of slider	Lead	Brake	Stroke	Controller (CA25-M10)	Cable length
BT : Facing up BR : Facing right BL : Facing left BU : Facing down	M : Medium slider L : Long slider	21 : 21mm	N : Without brake	Type designation	0 : None 1 : NPN output specifications Other : See page 19	3 : 3m 9 : 9m 5 : 5m B : 11m 7 : 7m D : 13m

[Specifications]

Motor	100 W AC servo motor (absolute)																								
Drive system	Timing belt																								
Ball screw lead (mm)	21																								
Stroke (mm) (in increments of 100 mm)	Medium slider	100~900	1000	1100	1200	1300	1400	1500	1600	1700	1800	1900	2000	2100	2200	2300	2400	2500	2600	2700	2800	2900	3000	3100	3200
	Type designation	10~90	A0	B0	C0	D0	E0	F0	G0	H0	JO	KO	LO	MO	NO	PO	Q0	R0	S0	T0	U0	V0	W00	W10	W20
	Long slider	150~950	1050	1150	1250	1350	1450	1550	1650	1750	1850	1950	2050	2150	2250	2350	2450	2550	2650	2750	2850	2950	3050	3150	
	Type designation	15~95	A5	B5	C5	D5	E5	F5	G5	H5	J5	K5	L5	M5	N5	P5	Q5	R5	S5	T5	U5	V5	W05	W15	
Maximum speed (mm/s)	1000																								
Maximum payload (kg) Acceleration/deceleration time: 0.3 sec or over	Horizontal transfer: 15																								
Positioning repeatability (mm)	± 0.04																								
Resolution (mm)	0.01																								
Allowable static load moment (N-m)	Medium slider MR : 510 MP : 430 MY : 370 Long slider MR : 510 MP : 750 MY : 650																								
Master controller	CA25-M10																								

Notes: * The maximum payload signifies a load exerted on top of the slider. Also refers to the description on the dynamic load moment appearing later in this document.
* The acceleration/deceleration time represents the time until the axis reaches a programmed speed.

Timing Belt Driven

[Axis designation]

BE30E – BT – M 21 N – 40

Motor set direction	Type of slider	Lead	Brake	Stroke
BT : Facing up BR : Facing right BL : Facing left BU : Facing down	M : Medium slider L : Long slider	21 : 21mm	N : Without brake	Type designation

[Dimensions]

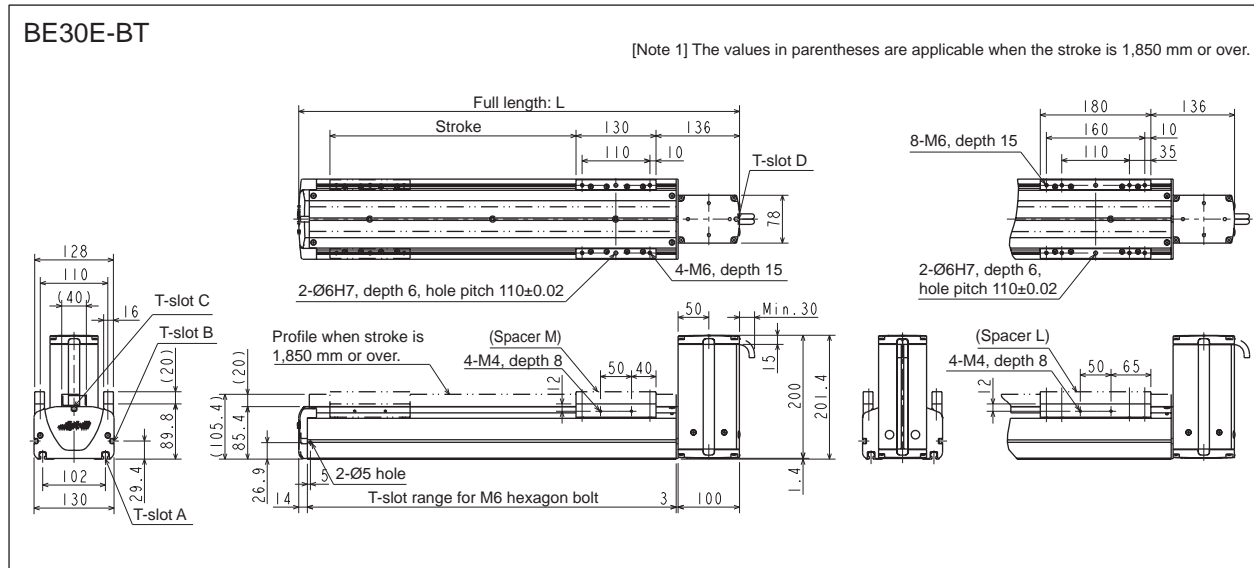

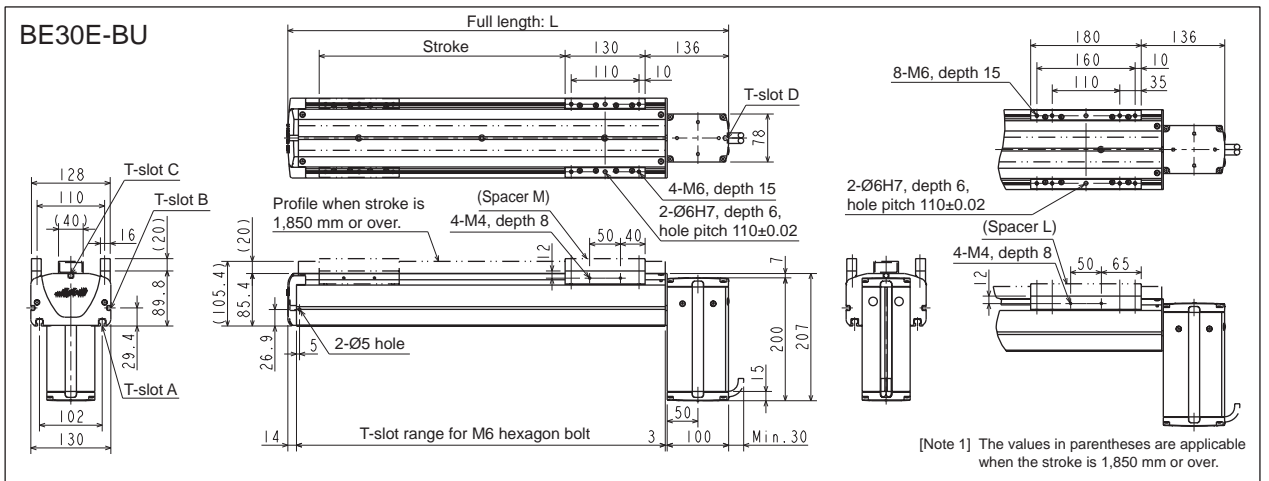
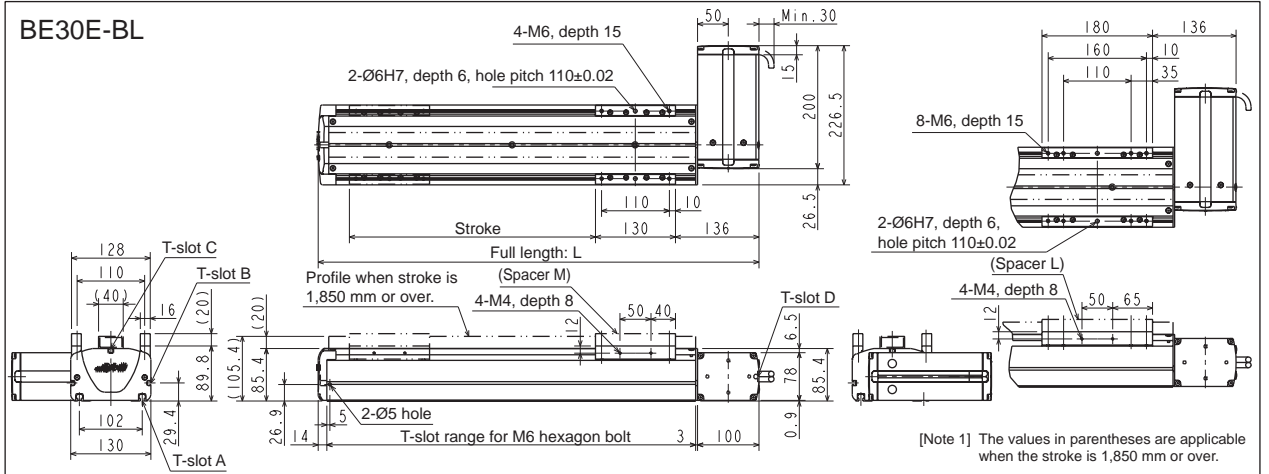
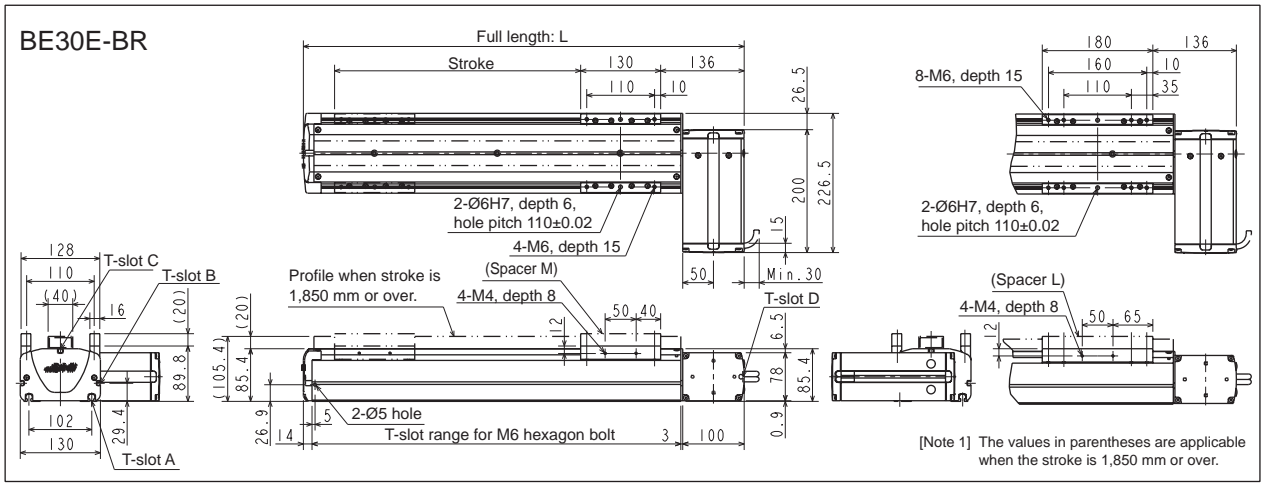

Common to BE30E-BT, BR, BL and BU.

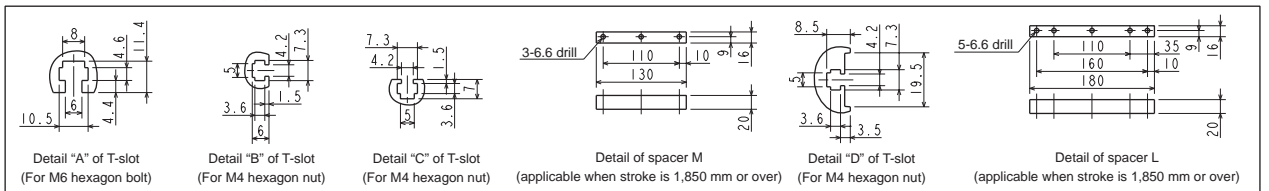

Medium slider Common to BE30E-BT, BR, BL and BU.

Stroke X (mm)	100	200	300	400	500	600	700	800	900	1000	1100	1200	1300	1400	1500	1600	1700	1800	1900	2000	2100	2200	2300	2400	2500	2600	2700	2800	2900	3000	3100	3200
Full length L (mm)	417	517	617	717	817	917	1017	1117	1217	1317	1417	1517	1617	1717	1817	1917	2017	2117	2217	2317	2417	2517	2617	2717	2817	2917	3017	3117	3217	3317	3417	3517
Weight (kg)	9.2	10.2	11.2	12.2	13.2	14.1	15.1	16.1	17.1	18.1	19.1	20.1	21.1	22.1	23.0	24.0	25.0	26.0	28.3	29.3	30.4	31.4	32.5	33.5	34.6	35.6	36.7	37.7	38.8	39.8	40.9	41.9

Long slider Common to BE30E-BT, BR, BL and BU.

Stroke X (mm)	150	250	350	450	550	650	750	850	950	1050	1150	1250	1350	1450	1550	1650	1750	1850	1950	2050	2150	2250	2350	2450	2550	2650	2750	2850	2950	3050	3150
Full length L (mm)	517	617	717	817	917	1017	1117	1217	1317	1417	1517	1617	1717	1817	1917	2017	2117	2217	2317	2417	2517	2617	2717	2817	2917	3017	3117	3217	3317	3417	3517
Weight (kg)	10.5	11.5	12.5	13.5	14.4	15.4	16.4	17.4	18.4	19.4	20.4	21.4	22.4	23.3	24.3	25.3	26.3	28.6	29.6	30.7	31.7	32.8	33.8	34.9	35.9	37.0	38.0	39.1	40.1	41.2	42.2

[Set designation]

BA3 - 30F - BT - M 21 N - 40 - 13

Motor set direction	Type of slider	Lead	Brake	Stroke	Controller (CA25-M10)	Cable length
BT : Facing up BR : Facing right BL : Facing left BU : Facing down	M : Medium slider L : Long slider	21 : 21mm 42 : 42mm	N : Without brake	Type designation	0 : None 1 : NPN output specifications Other : See page 19	3 : 3m 9 : 9m 5 : 5m B : 11m 7 : 7m D : 13m

[Specifications]

Motor	200 W AC servo motor (absolute)																								
Drive system	Timing belt																								
Ball screw lead (mm)	21, 42																								
Stroke (mm) (in increments of 100 mm)	Medium slider	100~900	1000	1100	1200	1300	1400	1500	1600	1700	1800	1900	2000	2100	2200	2300	2400	2500	2600	2700	2800	2900	3000	3100	3200
	Type designation	10~90	A0	B0	C0	D0	E0	F0	G0	H0	J0	K0	L0	M0	N0	P0	Q0	R0	S0	T0	U0	V0	W00	W10	W20
	Long slider	150~950	1050	1150	1250	1350	1450	1550	1650	1750	1850	1950	2050	2150	2250	2350	2450	2550	2650	2750	2850	2950	3050	3150	
Type designation	15~95	A5	B5	C5	D5	E5	F5	G5	H5	J5	K5	L5	M5	N5	P5	Q5	R5	S5	T5	U5	V5	W05	W15		
Maximum speed (mm/s)	Lead 21	1000																							
	Lead 42	2000																							
Maximum payload (kg)	Lead 21	Horizontal transfer: 40, acceleration/deceleration time: 0.3 sec. or over																							
	Lead 42	Horizontal transfer: 20, acceleration/deceleration time: 0.5 sec. or over																							
Positioning repeatability (mm)	± 0.04																								
Resolution (mm)	0.01																								
Allowable static load moment (N·m)	Medium slider MR : 510 MP : 430 MY : 370 Long slider MR : 510 MP : 750 MY : 650																								
Master controller	CA25-M10																								

Notes: * The maximum payload signifies a load exerted on top of the slider. Also refers to the description on the dynamic load moment appearing later in this document.

* The acceleration/deceleration time represents the time until the axis reaches a programmed speed.

[Axis designation]

BE30F - BT - M 21 N - 40

Motor set direction	Type of slider	Lead	Brake	Stroke
BT : Facing up BR : Facing right BL : Facing left BU : Facing down	M : Medium slider L : Long slider	21 : 21mm 42 : 42mm	N : Without brake	Type designation

Timing Belt Driven

[Dimensions]

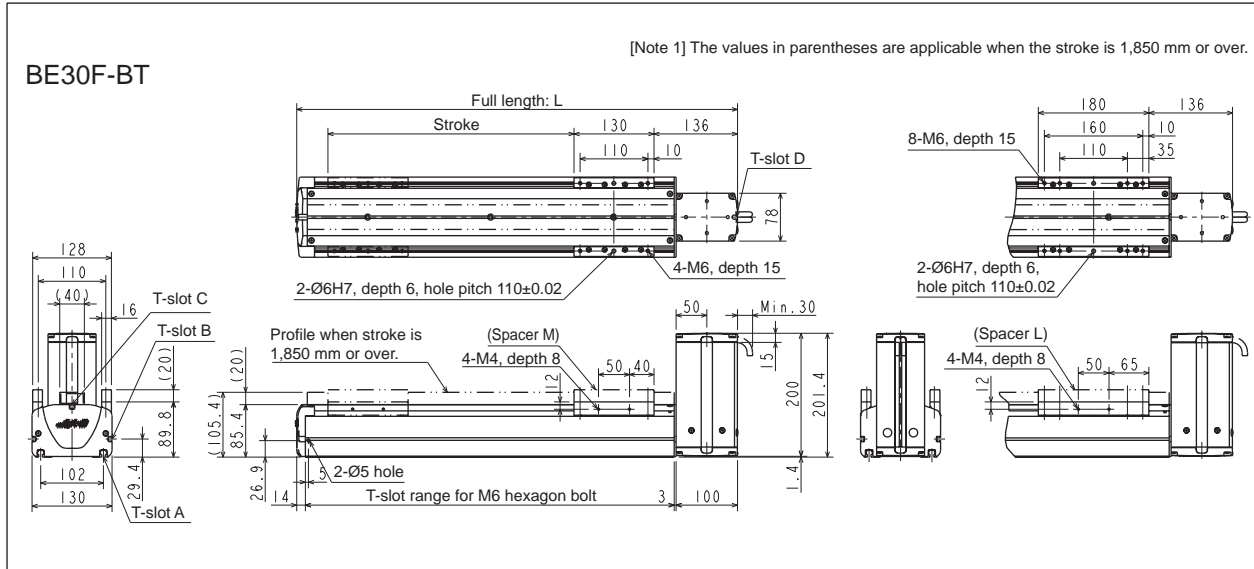

Common to BE30F-BT, BR, BL and BU.

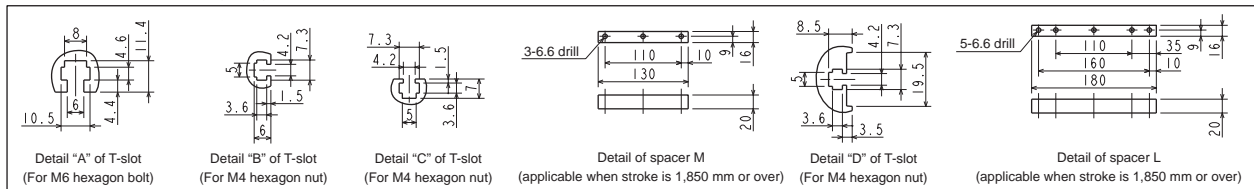

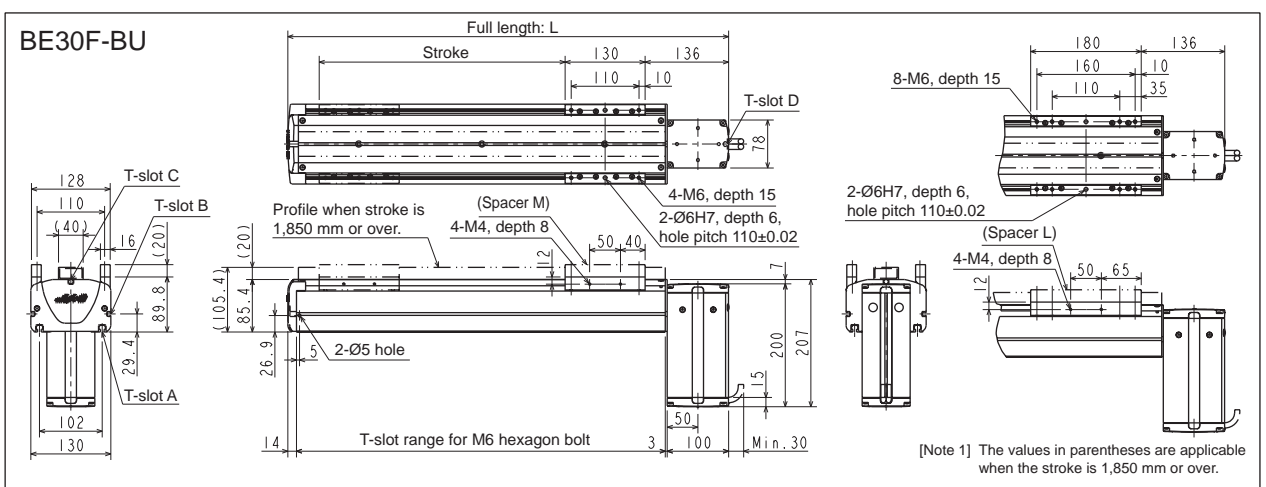
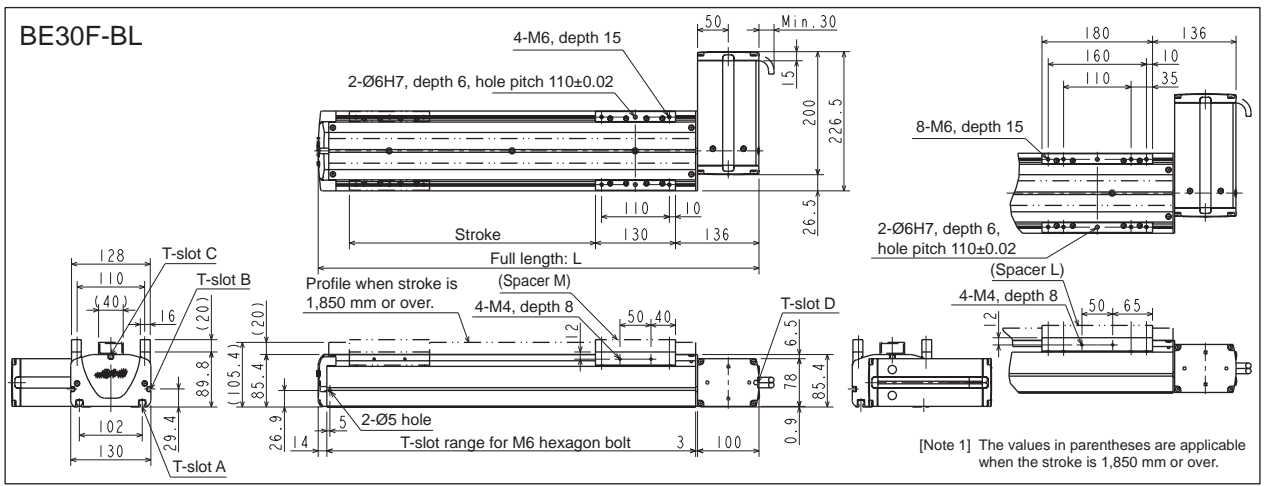
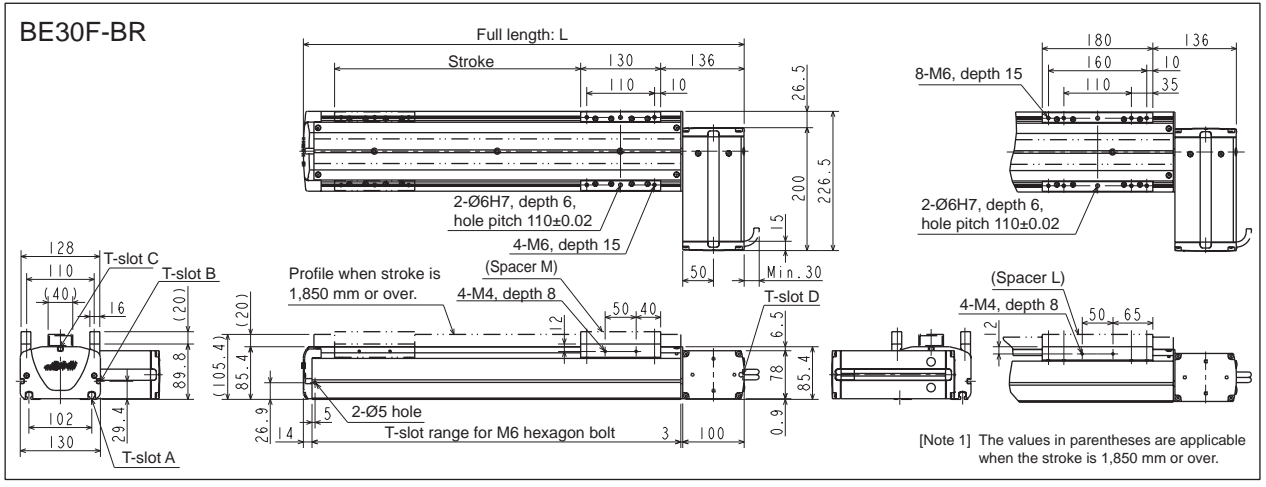

Medium slider Lead 21mm common to BE30F-BT, BR, BL and BU.

Stroke X (mm)	100	200	300	400	500	600	700	800	900	1000	1100	1200	1300	1400	1500	1600	1700	1800	1900	2000	2100	2200	2300	2400	2500	2600	2700	2800	2900	3000	3100	3200
Full length L (mm)	417	517	617	717	817	917	1017	1117	1217	1317	1417	1517	1617	1717	1817	1917	2017	2117	2217	2317	2417	2517	2617	2717	2817	2917	3017	3117	3217	3317	3417	3517
Weight (kg)	9.8	10.8	11.8	12.8	13.8	14.7	15.7	16.7	17.7	18.7	19.7	20.7	21.7	22.7	23.6	24.6	25.6	26.6	28.9	29.9	31.0	32.0	33.1	34.1	35.2	36.2	37.2	38.2	39.3	40.3	41.4	42.4

Long slider Lead 21mm common to BE30F-BT, BR, BL and BU.

Stroke X (mm)	150	250	350	450	550	650	750	850	950	1050	1150	1250	1350	1450	1550	1650	1750	1850	1950	2050	2150	2250	2350	2450	2550	2650	2750	2850	2950	3050	3150
Full length L (mm)	517	617	717	817	917	1017	1117	1217	1317	1417	1517	1617	1717	1817	1917	2017	2117	2217	2317	2417	2517	2617	2717	2817	2917	3017	3117	3217	3317	3417	3517
Weight (kg)	11.1	12.1	13.1	14.1	15.0	16.0	17.0	18.0	19.0	20.0	21.0	22.0	23.0	23.9	24.9	25.9	26.9	29.2	30.2	31.3	32.3	33.4	34.4	35.5	36.5	37.6	38.6	39.7	40.7	41.8	42.8

Medium slider Lead 42mm common to BE30F-BT, BR, BL and BU.

Stroke X (mm)	100	200	300	400	500	600	700	800	900	1000	1100	1200	1300	1400	1500	1600	1700	1800	1900	2000	2100	2200	2300	2400	2500	2600	2700	2800	2900	3000	3100	3200
Full length L (mm)	417	517	617	717	817	917	1017	1117	1217	1317	1417	1517	1617	1717	1817	1917	2017	2117	2217	2317	2417	2517	2617	2717	2817	2917	3017	3117	3217	3317	3417	3517
Weight (kg)	9.2	10.2	11.2	12.2	13.2	14.1	15.1	16.1	17.1	18.1	19.1	20.1	21.1	22.1	23.0	24.0	25.0	26.0	28.3	29.3	30.4	31.4	32.5	33.5	34.6	35.6	36.7	37.7	38.8	39.8	40.9	41.9

Long slider Lead 42mm common to BE30F-BT, BR, BL and BU.

Stroke X (mm)	150	250	350	450	550	650	750	850	950	1050	1150	1250	1350	1450	1550	1650	1750	1850	1950	2050	2150	2250	2350	2450	2550	2650	2750	2850	2950	3050	3150
Full length L (mm)	517	617	717	817	917	1017	1117	1217	1317	1417	1517	1617	1717	1817	1917	2017	2117	2217	2317	2417	2517	2617	2717	2817	2917	3017	3117	3217	3317	3417	3517
Weight (kg)	10.5	11.5	12.5	13.5	14.4	15.4	16.4	17.4	18.4	19.4	20.4	21.4	22.4	23.3	24.3	25.3	26.3	28.6	29.6	30.7	31.7	32.8	33.8	34.9	35.9	37.0	38.0	39.1	40.1	41.2	42.2

Timing Belt Driven

[Set designation]

BA3 – 50F – BT – M 21 N – 40 – 1 3

Motor set direction BT : Facing up BR : Facing right BL : Facing left BU : Facing down	Type of slider M : Medium slider L : Long slider	Lead 21 : 21mm	Brake N : Without brake	Stroke Type designation	Controller (CA25-M10) 0 : None 1 : NPN output specifications Other : See page 19	Cable length 3 : 3m 9 : 9m 5 : 5m B : 11m 7 : 7m D : 13m
--	--	-------------------	----------------------------	----------------------------	---	---

[Specifications]

Motor	200 W AC servo motor (absolute)																																
Drive system	Timing belt																																
Ball screw lead (mm)	21																																
Stroke (mm) (in increments of 100 mm)	Medium slider	200~900	1000	1100	1200	1300	1400	1500	1600	1700	1800	1900	2000	2100	2200	2300	2400	2500	2600	2700	2800	2900	3000	3100	3200	3300	3400	3500					
	Type designation	20~90	A0	B0	C0	D0	E0	F0	G0	H0	J0	K0	L0	M0	N0	P0	Q0	R0	S0	T0	U0	V0	W00	W10	W20	W30	W40	W50					
	Long slider	250~950	1050	1150	1250	1350	1450	1550	1650	1750	1850	1950	2050	2150	2250	2350	2450	2550	2650	2750	2850	2950	3050	3150	3250	3350	3450						
Maximum speed (mm/s)	1000																																
Maximum payload (kg) Acceleration/deceleration time: 0.3 sec or over	Horizontal transfer : 40																																
Positioning repeatability (mm)	± 0.04																																
Resolution (mm)	0.01																																
Allowable static load moment (N·m)	Medium slider	MR : 2080	MP : 2160	MY : 1820	Long slider																					MR : 2080	MP : 3150	MY : 2640					
Master controller	CA25-M10																																

Notes: * The maximum payload signifies a load exerted on top of the slider. Also refers to the description on the dynamic load moment appearing later in this document.

* The acceleration/deceleration time represents the time until the axis reaches a programmed speed.

Timing Belt Driven

[Axis designation]

BE50F – BT – M 21 N – 40

Motor set direction BT : Facing up BR : Facing right BL : Facing left BU : Facing down	Type of slider M : Medium slider L : Long slider	Lead 21 : 21mm	Brake N : Without brake	Stroke Type designation
--	--	-------------------	----------------------------	----------------------------

[Dimensions]

BE50F-BT

[Note 1] The values in parentheses are applicable when the stroke is 1,850 mm or over.

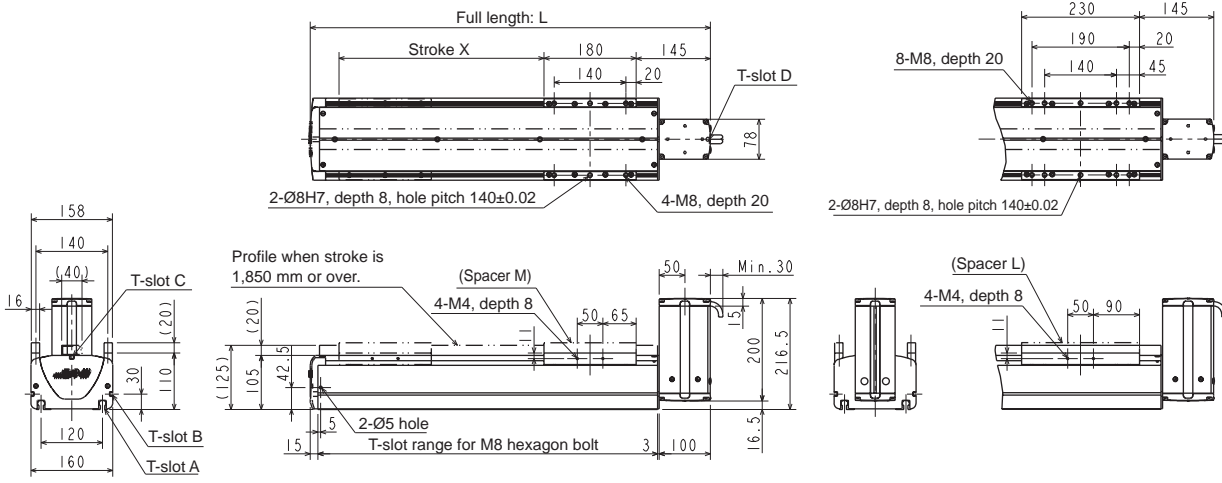

BE50F-BR

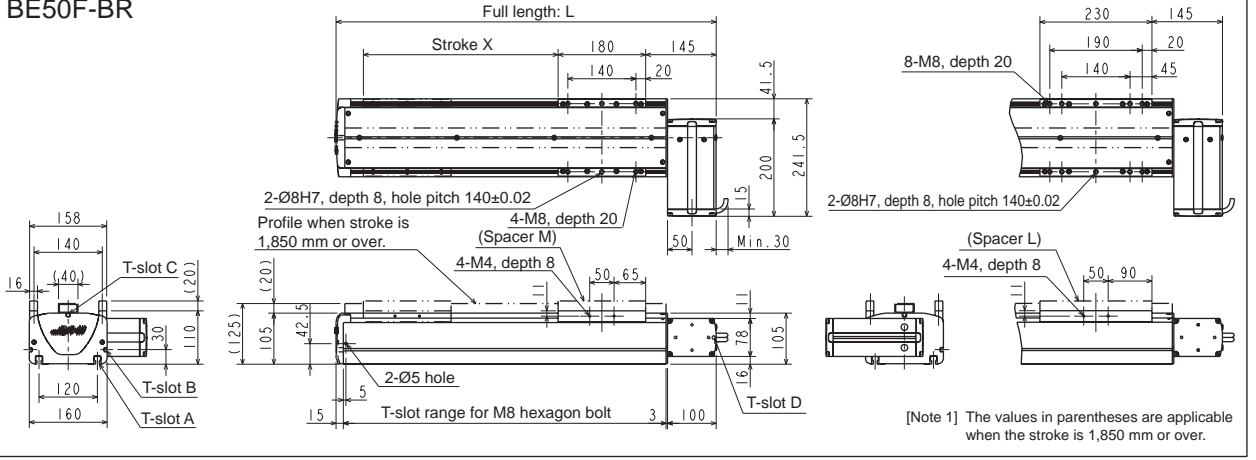

BE50F-BL

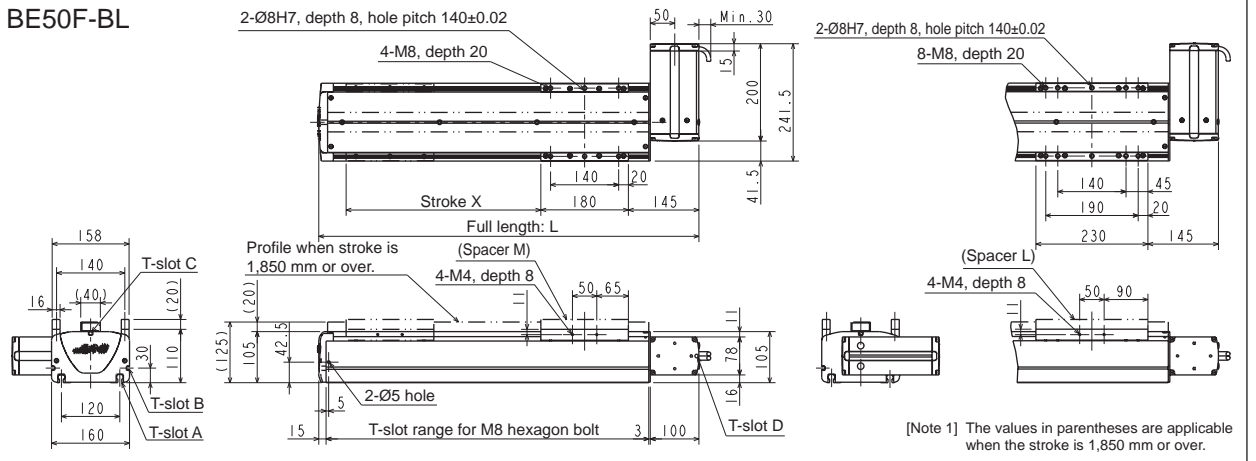

BE50F-BU

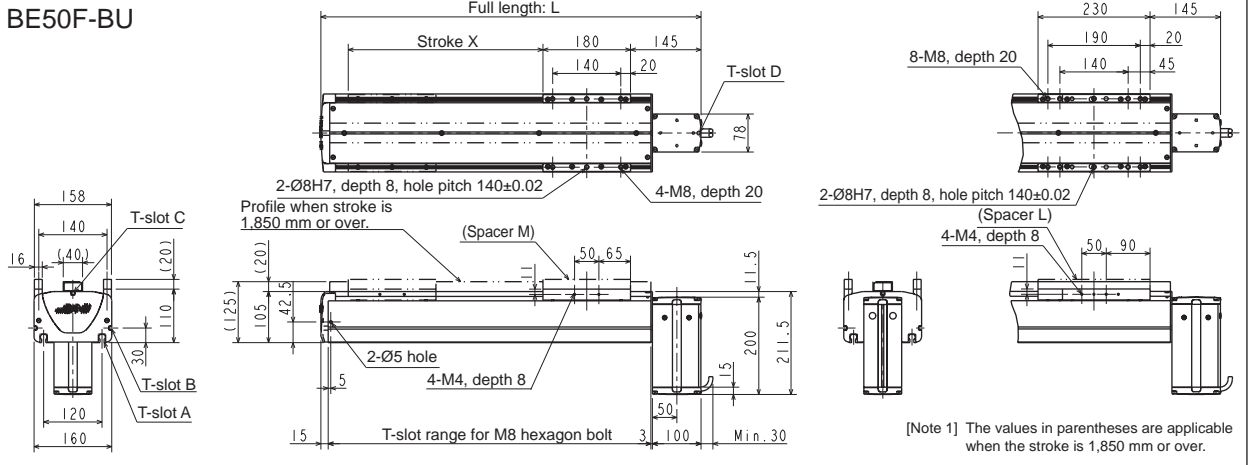

Common to BE50F-BT, BR, BL and BU.

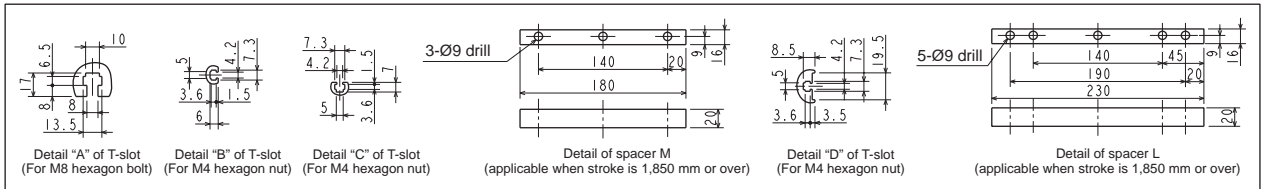

Medium slider Common to BE50F-BT, BR, BL and BU.

Stroke X (mm)	200	300	400	500	600	700	800	900	1000	1100	1200	1300	1400	1500	1600	1700	1800	1900	2000	2100	2200	2300	2400	2500	2600	2700	2800	2900	3000	3100	3200	3300	3400	3500
Full length L (mm)	581	681	781	881	981	1081	1181	1281	1381	1481	1581	1681	1781	1881	1981	2081	2181	2281	2381	2481	2581	2681	2781	2881	2981	3081	3181	3281	3381	3481	3581	3681	3781	3881
Weight (kg)	15.0	16.5	18.0	19.5	21.0	22.5	24.0	25.5	27.0	28.5	30.0	31.5	33.0	34.5	36.0	37.5	39.0	41.8	43.4	44.9	46.5	48.1	49.6	51.2	52.7	54.3	55.9	57.4	59.0	60.6	62.1	63.7	65.2	66.8

Long slider Common to BE50F-BT, BR, BL and BU.

Stroke X (mm)	250	350	450	550	650	750	850	950	1050	1150	1250	1350	1450	1550	1650	1750	1850	1950	2050	2150	2250	2350	2450	2550	2650	2750	2850	2950	3050	3150	3250	3350	3450
Full length L (mm)	681	781	881	981	1081	1181	1281	1381	1481	1581	1681	1781	1881	1981	2081	2181	2281	2381	2481	2581	2681	2781	2881	2981	3081	3181	3281	3381	3481	3581	3681	3781	3881
Weight (kg)	17.1	18.6	20.1	21.6	23.1	24.6	26.1	27.6	29.1	30.6	32.1	33.6	35.1	36.6	38.1	39.6	42.4	44.0	45.5	47.1	48.4	50.2	51.8	53.3	54.9	56.5	58.0	59.6	61.2	62.7	64.3	65.8	67.4

[Set designation]

BA3 – 50G – BT – M 42 N – 40 – 1 3

Motor set direction BT : Facing up BR : Facing right BL : Facing left BU : Facing down	Type of slider M : Medium slider L : Long slider	Lead 42 : 42mm	Brake N : Without brake	Stroke Type designation	Controller (CA25-M40) 0 : None 1 : NPN output specifications Other : See page 19	Cable length 3 : 3m 9 : 9m 5 : 5m B : 11m 7 : 7m D : 13m
--	--	-------------------	----------------------------	----------------------------	---	---

[Specifications]

Motor	400 W AC servo motor (absolute)																											
Drive system	Timing belt																											
Ball screw lead (mm)	42																											
Stroke (mm) (in increments of 100 mm)	Medium slider	200~900	1000	1100	1200	1300	1400	1500	1600	1700	1800	1900	2000	2100	2200	2300	2400	2500	2600	2700	2800	2900	3000	3100	3200	3300	3400	3500
	Type designation	20~90	A0	B0	C0	D0	E0	F0	G0	H0	J0	K0	L0	M0	N0	P0	Q0	R0	S0	T0	U0	V0	W00	W10	W20	W30	W40	W50
	Long slider	250~950	1050	1150	1250	1350	1450	1550	1650	1750	1850	1950	2050	2150	2250	2350	2450	2550	2650	2750	2850	2950	3050	3150	3250	3350	3450	
	Type designation	25~95	A5	B5	C5	D5	E5	F5	G5	H5	J5	K5	L5	M5	N5	P5	Q5	R5	S5	T5	U5	V5	W05	W15	W25	W35	W45	
Maximum speed (mm/s)	2000																											
Maximum payload (kg) Acceleration/deceleration time: 0.5 sec or over	Horizontal transfer : 20																											
Positioning repeatability (mm)	± 0.04																											
Resolution (mm)	0.01																											
Allowable static load moment (N·m)	Medium slider MR : 2080 MP : 2160 MY : 1820 Long slider MR : 2080 MP : 3150 MY : 2640																											
Master controller	CA25-M40																											

Notes: * The maximum payload signifies a load exerted on top of the slider. Also refers to the description on the dynamic load moment appearing later in this document.

* The acceleration/deceleration time represents the time until the axis reaches a programmed speed.

* The regenerative discharge unit ABSU-4000 is required regardless of the payload.

Timing Belt Driven

[Axis designation]

BE50G – BT – M 42 N – 40

Motor set direction BT : Facing up BR : Facing right BL : Facing left BU : Facing down	Type of slider M : Medium slider L : Long slider	Lead 42 : 42mm	Brake N : Without brake	Stroke Type designation
--	--	-------------------	----------------------------	----------------------------

[Dimensions]

BE50G-BT

[Note 1] The values in parentheses are applicable when the stroke is 1,850 mm or over.

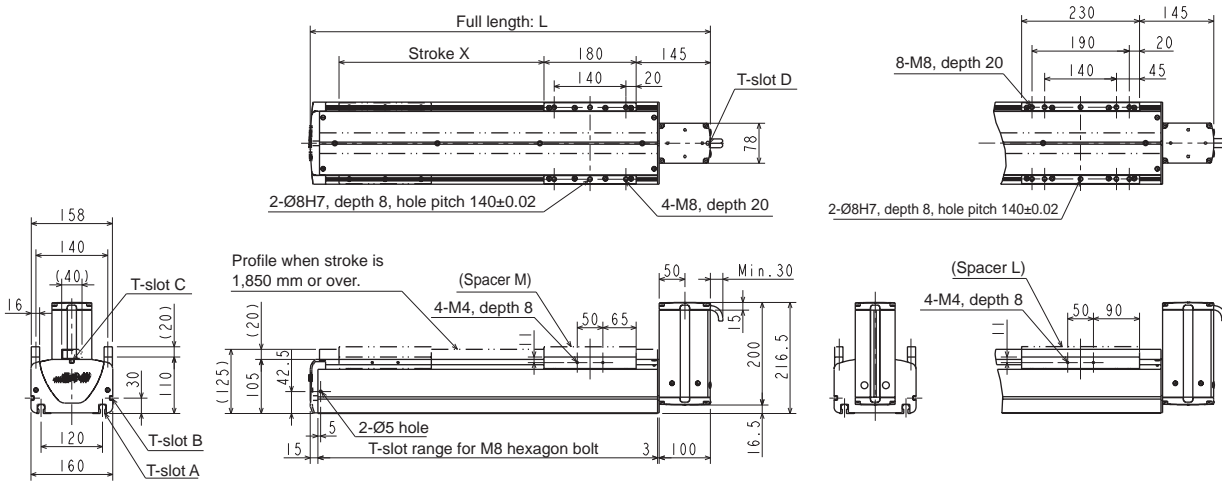

BE50G-BR

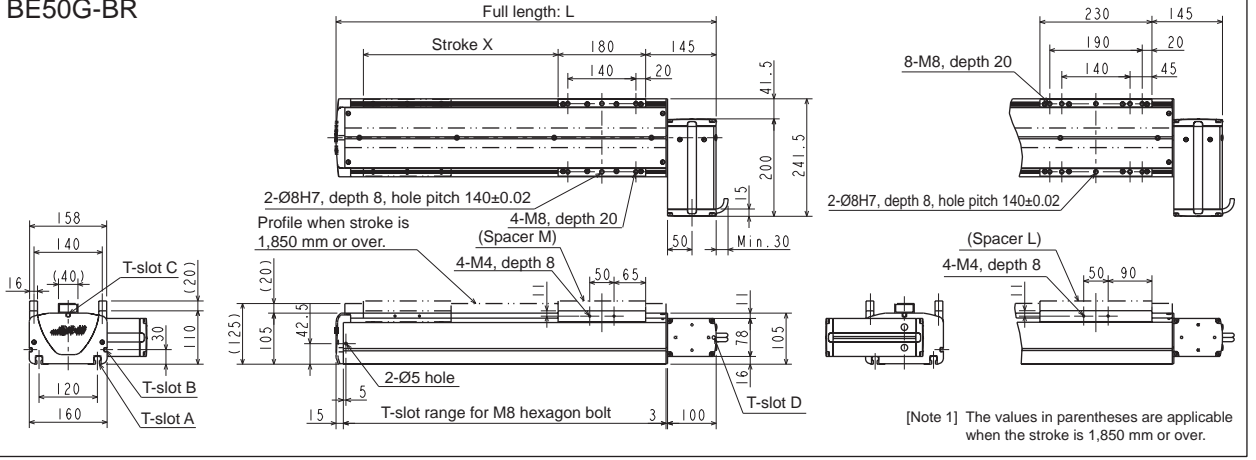

BE50G-BL

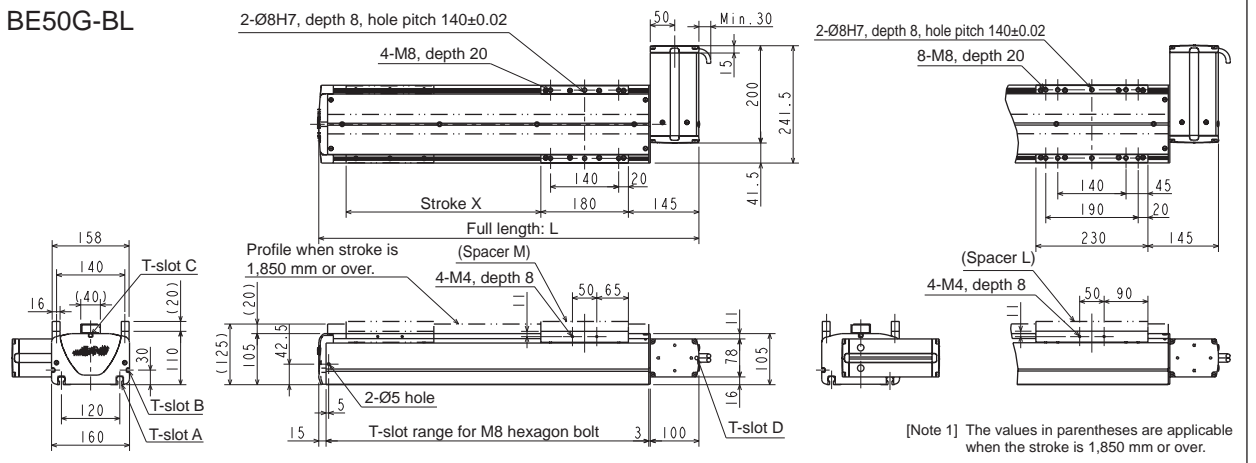

BE50G-BU

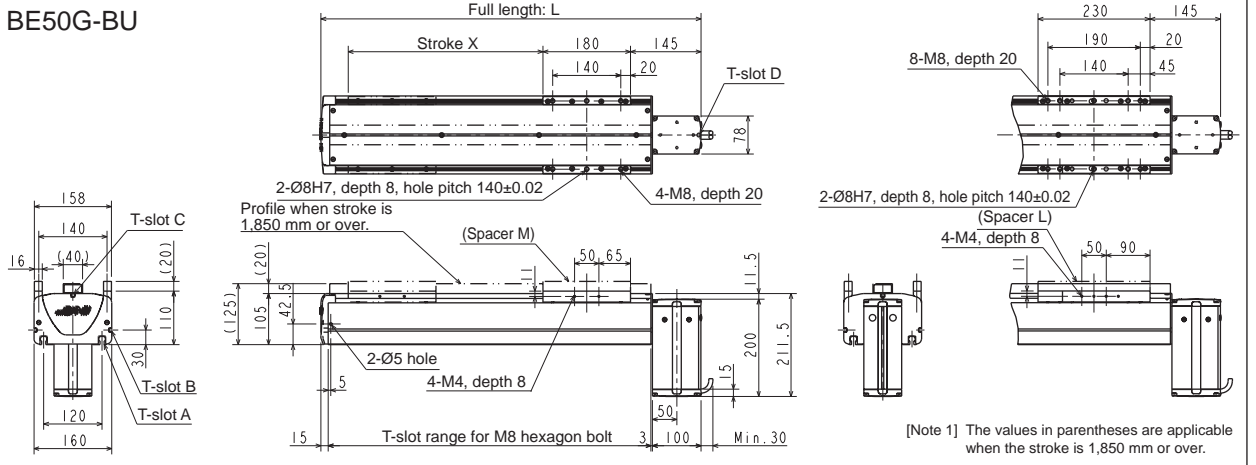

Common to BE50G-BT, BR, BL and BU.

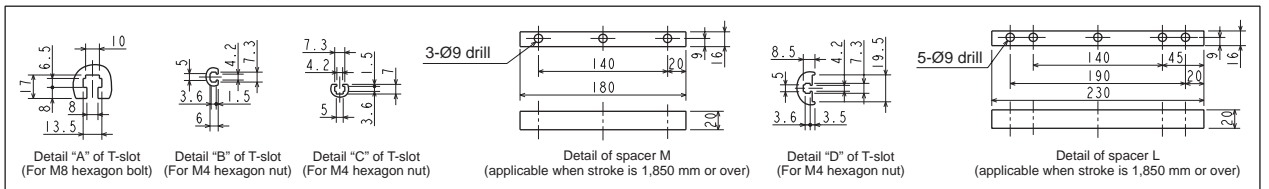

Medium slider Common to BE50G-BT, BR, BL and BU.

Stroke X (mm)	200	300	400	500	600	700	800	900	1000	1100	1200	1300	1400	1500	1600	1700	1800	1900	2000	2100	2200	2300	2400	2500	2600	2700	2800	2900	3000	3100	3200	3300	3400	3500
Full length L (mm)	581	681	781	881	981	1081	1181	1281	1381	1481	1581	1681	1781	1881	1981	2081	2181	2281	2381	2481	2581	2681	2781	2881	2981	3081	3181	3281	3381	3481	3581	3681	3781	3881
Weight (kg)	15.0	16.5	18.0	19.5	21.0	22.5	24.0	25.5	27.0	28.5	30.0	31.5	33.0	34.5	36.0	37.5	39.0	41.8	43.4	44.9	46.5	48.1	49.6	51.2	52.7	54.3	55.9	57.4	59.0	60.6	62.1	63.7	65.2	66.8

Long slider Common to BE50G-BT, BR, BL and BU.

Stroke X (mm)	250	350	450	550	650	750	850	950	1050	1150	1250	1350	1450	1550	1650	1750	1850	1950	2050	2150	2250	2350	2450	2550	2650	2750	2850	2950	3050	3150	3250	3350	3450
Full length L (mm)	681	781	881	981	1081	1181	1281	1381	1481	1581	1681	1781	1881	1981	2081	2181	2281	2381	2481	2581	2681	2781	2881	2981	3081	3181	3281	3381	3481	3581	3681	3781	3881
Weight (kg)	17.1	18.6	20.1	21.6	23.1	24.6	26.1	27.6	29.1	30.6	32.1	33.6	35.1	36.6	38.1	39.6	42.4	44.0	45.5	47.1	48.4	50.2	51.8	53.3	54.9	56.5	58.0	59.6	61.2	62.7	64.3	65.8	67.4

[Set designation]

BA3 – 50G – BT – L 19 N – A5 – 1 3

Type of slider
L : Long slider

Stroke
Type designation

Controller (CA25-M40)
0 : None
1 : NPN output specifications
Other : See page 19

Cable length
3 : 3m 9 : 9m
5 : 5m B : 11m
7 : 7m D : 13m

[Specifications]

Motor	400 W AC servo motor (absolute)	
Drive system	Timing belt	
Ball screw lead (mm)	19.555	
Maximum speed (mm/s)	1000	
Maximum payload (kg) Acceleration/deceleration time: 0.3 sec or over (Note 1)	Horizontal transfer : 100	
Stroke (mm) (in increments of 100 mm)	Long slider	150-950 1050 1150 1250 1350 1450 1550 1650 1750 1850 1950 2050 2150 2250 2350 2450 2550 2650 2750 2850 2950 3050 3150 3250 3350 3450 3550 3650 3750 3850 3950 4050 4150 4250 4350 4450
Allowable static load moment (N·m)	Long slider MR : 1800 MP : 2700 MY : 2150	
Positioning repeatability (mm)	±0.05	
Resolution (mm)	0.01	
Master controller	CA25-M40	

- Notes:
- * The acceleration/deceleration time represents the time until the axis reaches a programmed speed.
 - * The maximum payload signifies a load exerted on top of the slider. Also refers to the description on the dynamic load moment appearing later in this document.
 - * The regenerative discharge unit ABSU-4000 is required regardless of the payload.
- Note 1: A stroke of 1050 mm or more results in an acceleration time of 0.6 seconds or longer.

Timing Belt Driven

[Axis designation]

BE 50 G – BT – L 19 N – A5

Type of slider
L : Long slider

Stroke
Type designation

[Dimensions]

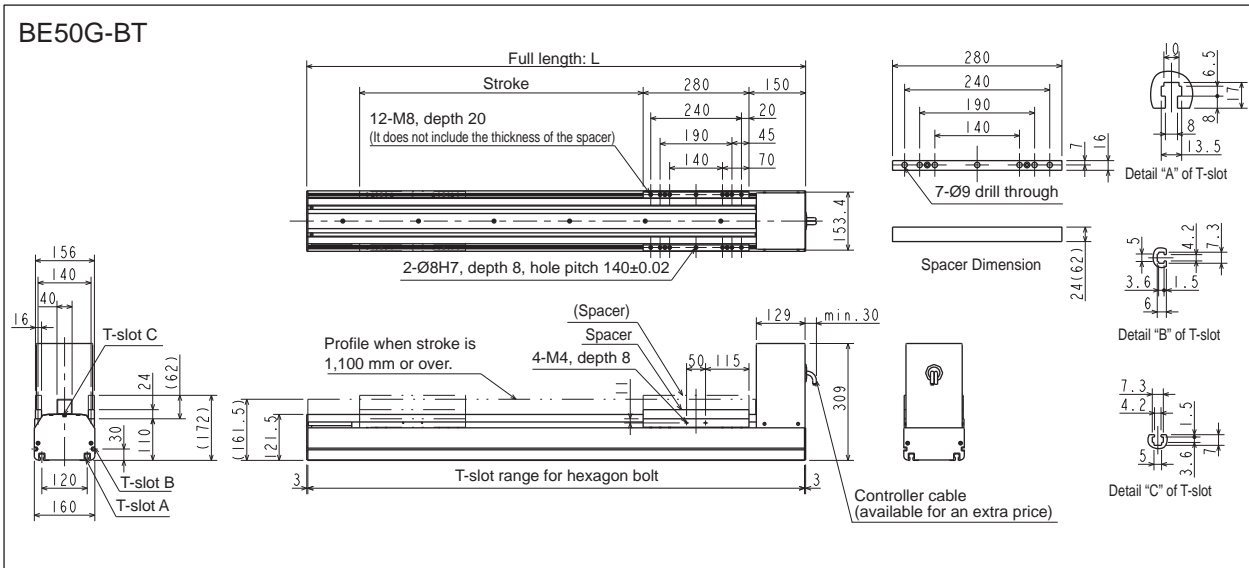

Long slider BE50G-BT-L19N

Stroke X (mm)	150	250	350	450	550	650	750	850	950	1050	1150	1250	1350	1450	1550	1650	1750	1850	1950	2050	2150	2250
Full length L (mm)	720	820	920	1020	1120	1220	1320	1420	1520	1620	1720	1820	1920	2020	2120	2220	2320	2420	2520	2620	2720	2820
Weight (kg)	26.6	28.0	29.3	30.7	32.0	33.4	34.7	36.1	37.4	37.2	40.2	41.5	42.9	44.2	45.6	46.9	48.3	49.6	51.0	52.3	53.7	55.0
Stroke X (mm)	2350	2450	2550	2650	2750	2850	2950	3050	3150	3250	3350	3450	3550	3650	3750	3850	3950	4050	4150	4250	4350	4450
Full length L (mm)	2920	3020	3120	3220	3320	3420	3520	3620	3720	3820	3920	4020	4120	4220	4320	4420	4520	4620	4720	4820	4920	5020
Weight (kg)	56.4	57.7	59.1	60.4	61.8	63.1	64.5	65.9	67.2	68.6	69.9	71.3	72.6	74.0	75.3	76.7	78.0	79.1	80.7	82.1	83.4	84.8

[Set designation]

BA3 – 60J – BT – M 19 N – A5 – 1 3

Type of slider

M : Medium slider
L : Long slider

Stroke

Type designation

Controller (CA25-M80)

0 : None
1 : NPN output specifications
Other : See page 19

Cable length

3 : 3m 9 : 9m
5 : 5m B : 11m
7 : 7m D : 13m

[Specifications]

Motor	750 W AC servo motor (absolute)																																				
Drive system	Timing belt																																				
Ball screw lead (mm)	19.555																																				
Maximum speed (mm/s)	1000																																				
Maximum payload (kg) Acceleration/deceleration time: 0.3 sec or over (Note 1)	Horizontal transfer : 200																																				
Stroke (mm) (in increments of 100 mm)	Medium, Long slider	150-95	1050	1150	1250	1350	1450	1550	1650	1750	1850	1950	2050	2150	2250	2350	2450	2550	2650	2750	2850	2950	3050	3150	3250	3350	3450	3550	3650	3750	3850	3950	4050	4150	4250	4350	4450 (Note: 1)
Allowable static load moment (N·m)	Type designation	15-95	A5	B5	C5	D5	E5	F5	G5	H5	J5	K5	L5	M5	N5	P5	Q5	R5	S5	T5	U5	V5	W05	W15	W25	W35	W45	W55	W65	W75	W85	W95	X05	X15	X25	X35	X45
Positioning repeatability (mm)	±0.05																																				
Resolution (mm)	0.01																																				
Master controller	CA25-M80																																				

- Notes: * The acceleration/deceleration time represents the time until the axis reaches a programmed speed.
 * The maximum payload signifies a load exerted on top of the slider. Also refers to the description on the dynamic load moment appearing later in this document.
 * The regenerative discharge unit ABSU-8000 is required regardless of the payload.
 Note 1: The long slider does not have a stroke of 4450 mm.

[Axis designation]

BE 60 J – BT – M 19 N – A5

Type of slider

M : Medium slider
L : Long slider

Stroke

Type designation

[Dimensions]

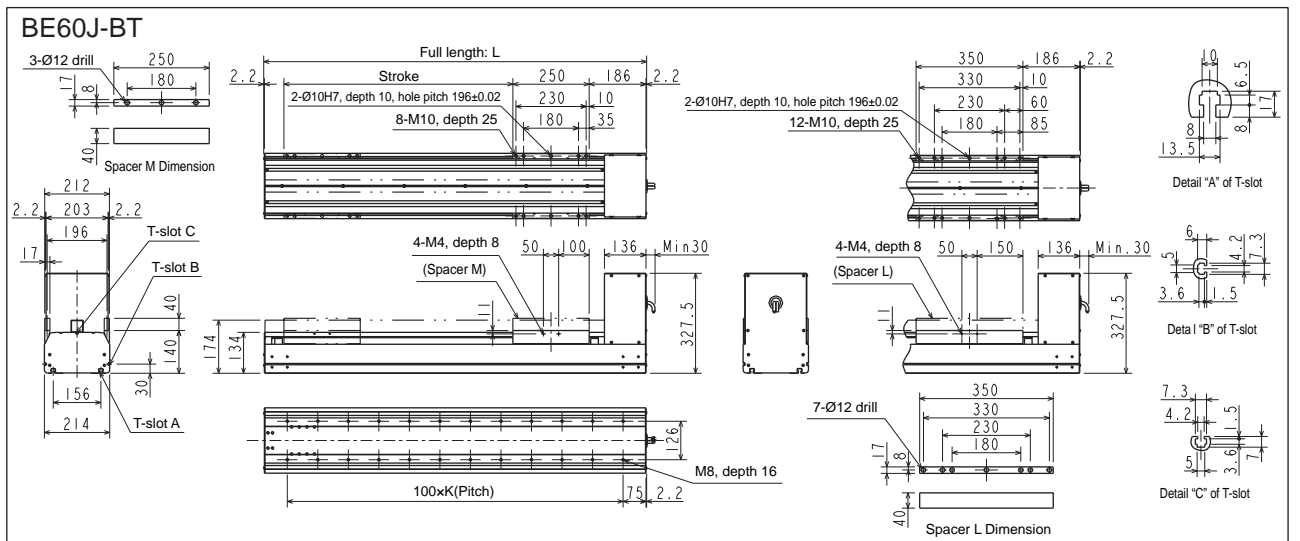

Medium slider BE60J-BT-M19N

Stroke X (mm)	150	250	350	450	550	650	750	850	950	1050	1150	1250	1350	1450	1550	1650	1750	1850	1950	2050	2150	2250
Full length L (mm)	650	750	850	950	1050	1150	1250	1350	1450	1550	1650	1750	1850	1950	2050	2150	2250	2350	2450	2550	2650	2750
K	5	6	7	8	9	10	11	12	13	14	15	16	17	18	19	20	21	22	23	24	25	26
Weight (kg)	40.8	43.1	45.4	47.7	50.0	52.3	54.6	56.9	59.2	61.5	63.8	66.1	68.4	70.7	73.0	75.3	77.6	79.9	82.2	84.5	86.9	89.2

Stroke X (mm)	2350	2450	2550	2650	2750	2850	2950	3050	3150	3250	3350	3450	3550	3650	3750	3850	3950	4050	4150	4250	4350	4450
Full length L (mm)	2850	2950	3050	3150	3250	3350	3450	3550	3650	3750	3850	3950	4050	4150	4250	4350	4450	4550	4650	4750	4850	4950
K	27	28	29	30	31	32	33	34	35	36	37	38	39	40	41	42	43	44	45	46	47	48
Weight (kg)	91.5	93.8	96.1	98.4	100.7	103.0	105.3	107.6	109.9	112.2	114.5	116.8	119.1	121.4	123.7	126.0	128.3	130.6	132.9	135.2	137.6	139.9

Long slider BE60J-BT-M19N

Stroke X (mm)	150	250	350	450	550	650	750	850	950	1050	1150	1250	1350	1450	1550	1650	1750	1850	1950	2050	2150	2250
Full length L (mm)	750	850	950	1050	1150	1250	1350	1450	1550	1650	1750	1850	1950	2050	2150	2250	2350	2450	2550	2650	2750	2850
K	6	7	8	9	10	11	12	13	14	15	16	17	18	19	20	21	22	23	24	25	26	27
Weight (kg)	44.1	46.4	48.7	51.0	53.3	55.6	57.9	60.2	62.5	64.8	67.1	69.4	71.7	74.0	76.3	78.6	80.9	83.2	85.5	87.9	90.2	92.5

Stroke X (mm)	2350	2450	2550	2650	2750	2850	2950	3050	3150	3250	3350	3450	3550	3650	3750	3850	3950	4050	4150	4250	4350	4450
Full length L (mm)	2950	3050	3150	3250	3350	3450	3550	3650	3750	3850	3950	4050	4150	4250	4350	4450	4550	4650	4750	4850	4950	5050
K	28	29	30	31	32	33	34	35	36	37	38	39	40	41	42	43	44	45	46	47	48	49
Weight (kg)	94.8	97.1	99.4	101.7	104.0	106.3	108.6	110.9	113.2	115.5	117.8	120.1	122.4	124.7	127.0	129.3	131.6	133.9	136.2	138.6	140.9	143.2

[Set designation]

BA3 - 00D - RH - A 00N - 36 - 1 3

Drive system RH: Harmonic	Mounting A: L-shaped bracket F: Flange type	Range of rotation 360°	Controller (CA25-M10) 0 : None 1 : NPN output specifications Other : See page 19	Cable length 3 : 3m 9 : 9m 5 : 5m B : 11m 7 : 7m D : 13m
------------------------------	---	---------------------------	---	---

[Specifications]

Motor	50 W AC servo motor (absolute)	
Drive system	Harmonic drive	
Reduction ratio (deg.)	1/50	
Range of rotation (deg.)	360	
Maximum speed (deg./s)	360	
Maximum payload (kg)	10	
Acceleration/deceleration time: 0.3 sec. or over		
Rated output torque (N·m)	5.4	
Allowable load inertia (kg·m ²)	0.0485	
Allowable thrust load on axis (N)	98	
Allowable radial load on axis (N)	196	
Allowable load moment on axis (N·m)	1.3	
Positioning repeatability (deg.)	± 0.025	
Resolution (deg.)	0.01	
Mass of axis (kg)	L-shaped bracket	1.9
	Flange type	1.7
Master controller	CA25-M10	

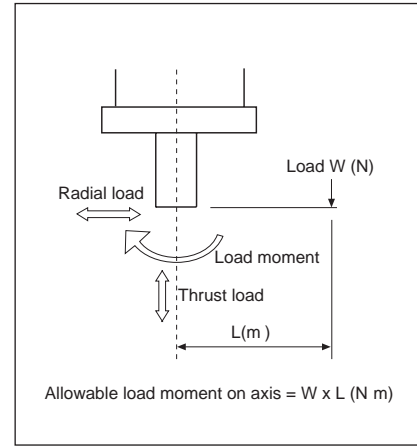

Notes: * The maximum payload signifies a load measured when only thrust load is exerted on the vertically installed axis.
* The acceleration/deceleration time represents the time until the axis reaches a programmed speed.

R-AXIS

[Axis designation]

BE00D - RH - A

Drive system RH: Harmonic	Mounting A: L-shaped bracket F: Flange type
------------------------------	---

[Dimensions]

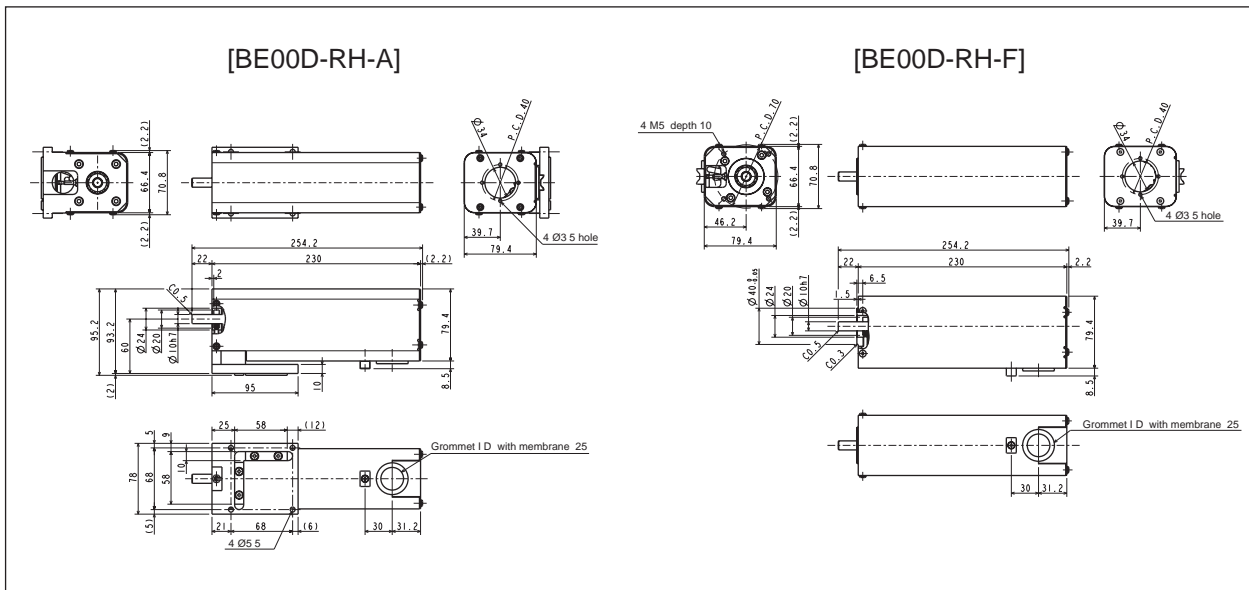

[Set designation]

BA3 – T3D – ST – C 12 N – 10 – 13

Type of slider C : Pushrod type	Lead 12 : 12mm	Brake N : Without brake B : With brake	Stroke Type designation	Controller (CA25-M10) 0 : None 1 : NPN output specifications Other : See page 19	Cable length 3 : 3m 9 : 9m 5 : 5m B : 11m 7 : 7m D : 13m
------------------------------------	-------------------	--	----------------------------	---	---

[Specifications]

Motor	50 W AC servo motor (absolute)	
Drive system	Precisely rolled ball screw, thread outer diameter 8 mm	
Stroke (mm) (in increments of 50 mm)	Pushrod	50 ~ 150
	Type designation	05 ~ 15
Maximum speed (mm/s)	600	
Maximum payload (kg) Acceleration/deceleration time: 0.3 sec or over	Horizontal transfer: 4 Vertical transfer: 1.9	
Positioning repeatability (mm)	± 0.02	
Resolution (mm)	0.01	
Allowable static load moment (N·m)	Do not apply load moment to the rod	
Brake	Brake voltage DC24 V	
Master controller	CA25-M10	

- Notes: * When using the axis as a vertical axis, select the type with brake.
 * A dynamic moment of inertia for the load cannot be applied to the rod. Take precautions by using together with a linear guide and other components to ensure that a radial load is not applied to the rod.
 * The acceleration/deceleration time represents the time until the axis reaches a programmed speed.

[Axis designation]

BET3D – ST – C 12 N – 10

Type of slider C : Pushrod type	Lead 12 : 12mm	Brake N : Without brake B : With brake	Stroke Type designation
------------------------------------	-------------------	--	----------------------------

Pushrod

BET3D-ST

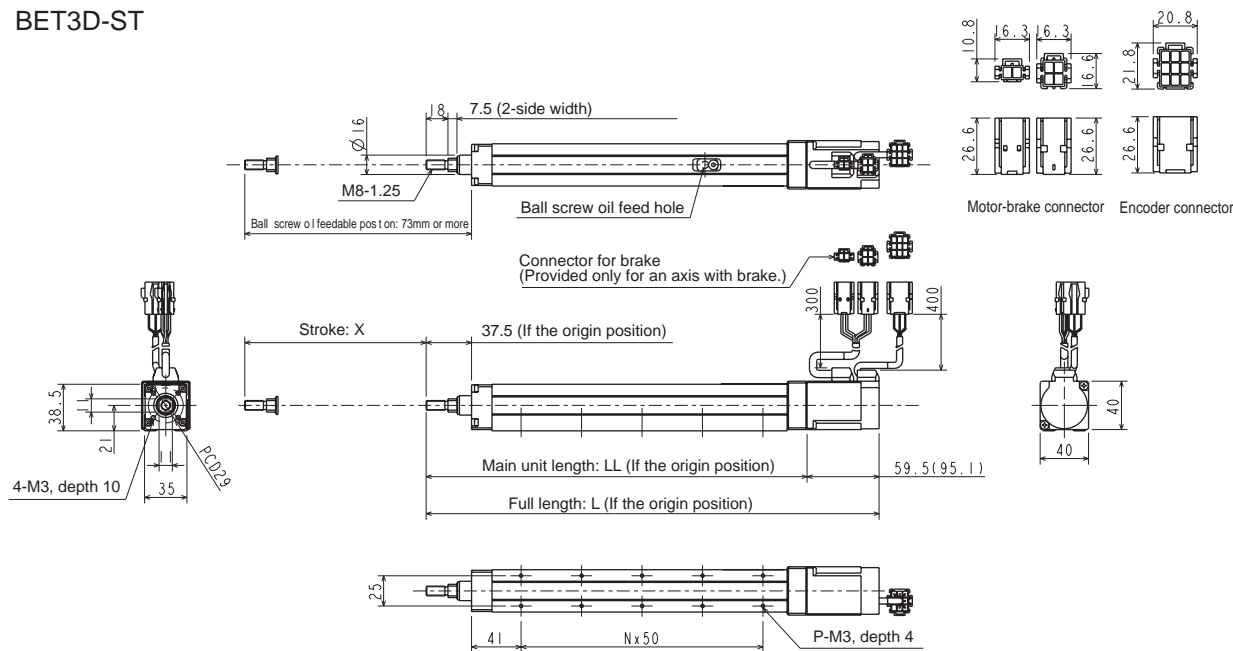

Stroke X (mm)	50	100	150
Full length L (mm)	274.5 (310.1)	324.5 (360.1)	374.5 (410.1)
Main unit length LL (mm)	215	265	315
No. of holes P (q'ty)	6	8	10
Intervals between mounting holes N	2	3	4
Weight (kg)	1.0 (1.2)	1.2 (1.4)	1.3 (1.5)

* Values in parentheses are for axis with brake.

[Set designation]

BA3 – T4D – ST – C 12 N – 10 – 13

Type of slider C : Pushrod type	Lead 12 : 12mm	Brake N : Without brake B : With brake	Stroke Type designation	Controller (CA25-M10) 0 : None 1 : NPN output specifications Other : See page 19	Cable length 3 : 3m 9 : 9m 5 : 5m B : 11m 7 : 7m D : 13m
------------------------------------	-------------------	--	----------------------------	---	---

[Specifications]

Motor	50 W AC servo motor (absolute)	
Drive system	Precisely rolled ball screw, thread outer diameter 8 mm	
Stroke (mm) (in increments of 50 mm)	Pushrod	50 ~ 200
	Type designation	05 ~ 20
Maximum speed (mm/s)	600	
Maximum payload (kg) Acceleration/deceleration time: 0.3 sec or over	Horizontal transfer: 7 Vertical transfer: 3.1	
Positioning repeatability (mm)	± 0.02	
Resolution (mm)	0.01	
Allowable static load moment (N·m)	Do not apply load moment to the rod	
Brake	Brake voltage DC24 V	
Master controller	CA25-M10	

Notes: * When using the axis as a vertical axis, select the type with brake.

* A dynamic moment of inertia for the load cannot be applied to the rod. Take precautions by using together with a linear guide and other components to ensure that a radial load is not applied to the rod.

* The acceleration/deceleration time represents the time until the axis reaches a programmed speed.

[Axis designation]

BET4D – ST – C 12 N – 10

Type of slider C : Pushrod type	Lead 12 : 12mm	Brake N : Without brake B : With brake	Stroke Type designation
------------------------------------	-------------------	--	----------------------------

Pushrod

BET4D-ST

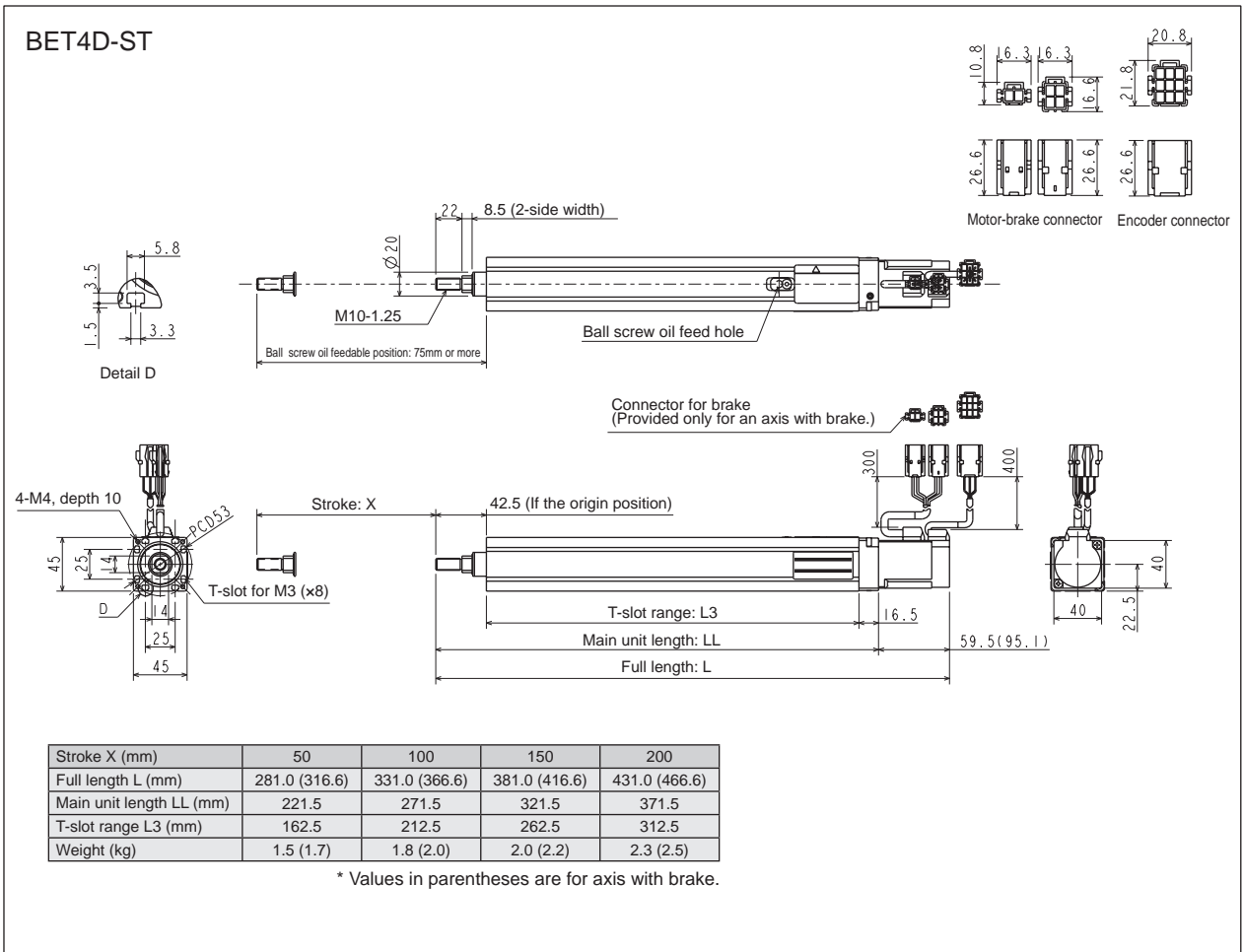

[Set designation]

BA3 – T5E – ST – C 12 N – 10 – 13

Type of slider C : Pushrod type	Lead 12 : 12mm	Brake N : Without brake B : With brake	Stroke Type designation 05 ~ 25	Controller (CA25-M10) 0 : None 1 : NPN output specifications Other : See page 19	Cable length 3 : 3m 9 : 9m 5 : 5m B : 11m 7 : 7m D : 13m
------------------------------------	-------------------	--	---------------------------------------	---	---

[Specifications]

Motor	100 W AC servo motor (absolute)		
Drive system	Precisely rolled ball screw, thread outer diameter 12 mm		
Stroke (mm) (in increments of 50 mm)	Pushrod	50 ~ 250	300
	Type designation	05 ~ 25	30
Maximum speed (mm/s)	Lead12mm	600	470
Maximum payload (kg) Acceleration/deceleration time: 0.3 sec or over	Horizontal transfer: 25 Vertical transfer: 6.5		
Positioning repeatability (mm)	± 0.02		
Resolution (mm)	0.01		
Allowable static load moment (N·m)	Do not apply load moment to the rod		
Brake	Brake voltage DC24 V		
Master controller	CA25-M10		

- Notes:
- * When using the axis as a vertical axis, select the type with brake.
 - * A dynamic moment of inertia for the load cannot be applied to the rod. Take precautions by using together with a linear guide and other components to ensure that a radial load is not applied to the rod.
 - * The acceleration/deceleration time represents the time until the axis reaches a programmed speed.

[Axis designation]

BET5E – ST – C 12 N – 10

Type of slider C : Pushrod type	Lead 12 : 12mm	Brake N : Without brake B : With brake	Stroke Type designation
------------------------------------	-------------------	--	----------------------------

Pushrod

BET5E-ST

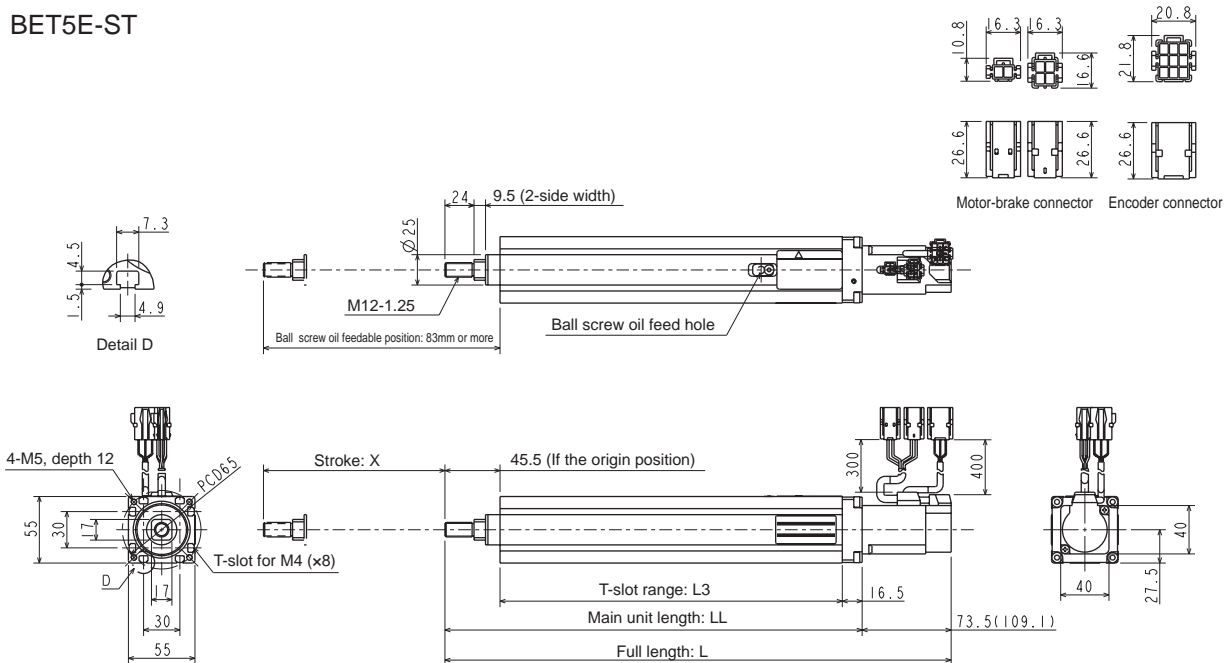

Stroke X (mm)	50	100	150	200	250	300
Full length L (mm)	318.5 (354.1)	368.5 (404.1)	418.5 (454.1)	468.5 (504.1)	518.5 (554.1)	568.5 (604.1)
Main unit length LL (mm)	245.0	295.0	345.0	395.0	445.0	495.0
T-slot range L3 (mm)	183.0	233.0	283.0	333.0	383.0	433.0
Weight (kg)	2.2 (2.4)	2.6 (2.8)	3.0 (3.2)	3.3 (3.5)	3.7 (3.9)	4.1 (4.3)

* Values in parentheses are for axis with brake.

Cartesian Axes Specifications

2-Axis Specifications

X-Y Combination

Ball screw type56

Timing belt type.....70

X-Z Combination

Ball screw type.....77

Timing belt type.....83

Y-Z Combination

Ball screw type89

Timing belt type.....96

Z-Y Combination

Ball screw type.....102

Timing belt type.....107

3-Axis Specifications

X-Y-Z Combination

Ball screw type.....113

Timing belt type.....129

4-Axis Specifications

X-Y-Z-R Combination

Harmonic drive type134

Planet gear type138

[Set designation]

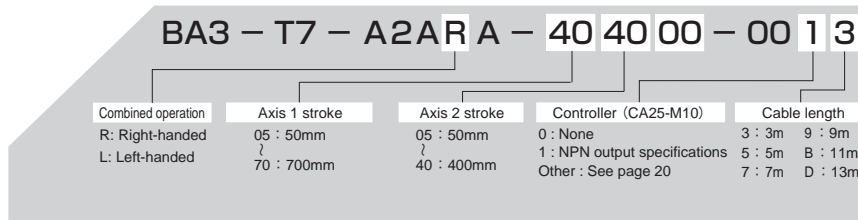

Ball screw type

X-axis: Ball screw driven
Motor straight

Y-axis: Ball screw driven
Motor straight

[Specifications]

	X-axis	Y-axis
Type of axis	BET7D-ST-M12N- □□	BET5D-ST-M12N- □□
Stroke (mm) (in increments of 50 mm)	50 ~ 600, 700	50 ~ 400
Maximum speed (mm/s)	800 (Note 1)	800
Positioning repeatability (mm)	± 0.02	
Lead of ball screw (mm)	12	12
Motor output	50W	50W
Resolution (mm)	0.01	

Note 1: When the stroke is as given below, the maximum speed differs.

	Stroke (mm)	Maximum speed (mm/s)
X-axis	50~550	800
	600	680
	700	500

Acceleration/deceleration time when the maximum speed is set: 0.3 sec. or over

Maximum payload (kg)	Y-axis stroke							
	50mm	100mm	150mm	200mm	250mm	300mm	350mm	400mm
	5.0	5.0	4.0	4.0	2.0	2.0	1.0	1.0

R: Right-handed

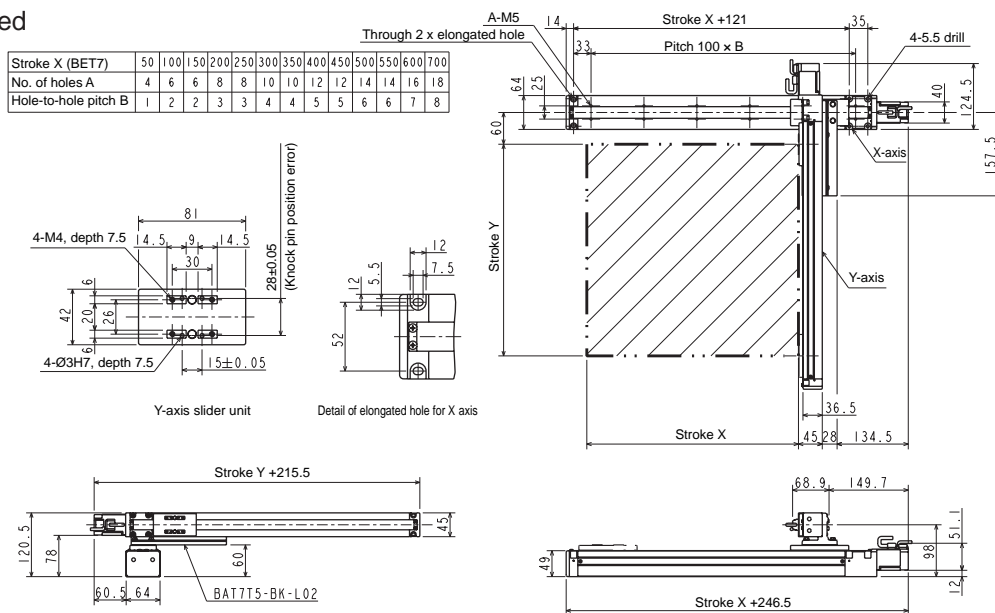

L: Left-handed

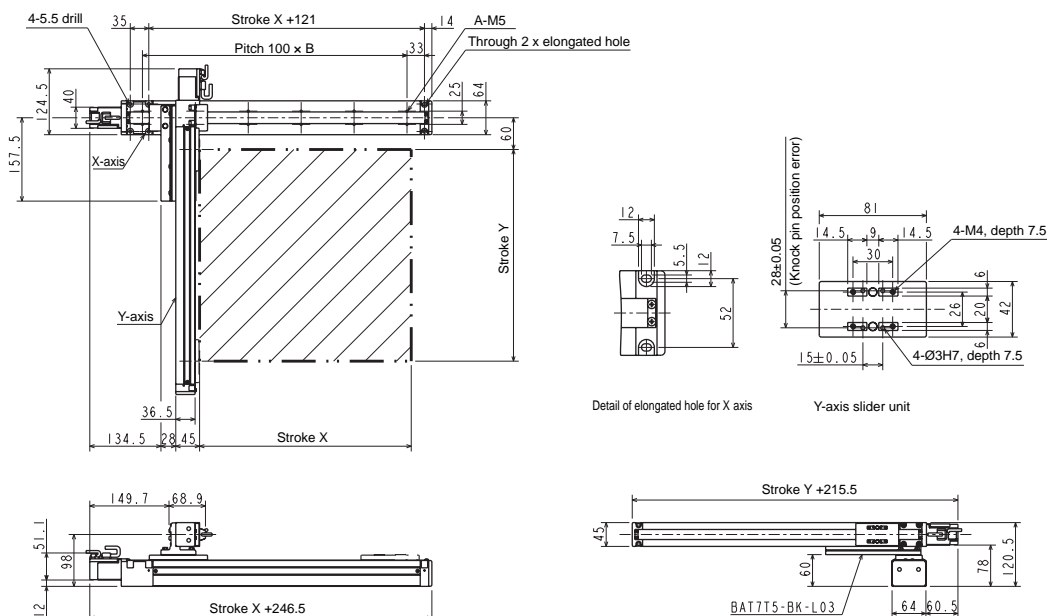

A-X

[Set designation]

BA3 – A1 – A2ER A – 45 40 00 – OF 1 3

Combined operation R: Right-handed L: Left-handed	Axis 1 stroke 15 : 150mm 95 : 950mm A5 : 1050mm C5 : 1250mm	Axis 2 stroke 05 : 50mm 40 : 400mm	Controller (CA25-M10) 0 : None 1 : NPN output specifications Other : See page 20	Cable length 3 : 3m 9 : 9m 5 : 5m B : 11m 7 : 7m D : 13m
---	---	--	---	---

Ball screw type

X-axis: Ball screw driven
Motor straight

Y-axis: Ball screw driven
Motor straight

[Specifications]

	X-axis	Y-axis
Type of axis	BE10E-ST-S20N-□5	BET7D-ST-M12N-□□
Stroke (mm) (in increments of 100 mm for X-axis, 50 mm for Y-axis)	150 ~ 1250	50 ~ 400
Maximum speed (mm/s)	1200 (Note 1)	800
Positioning repeatability (mm)	±0.01	±0.02
Lead of ball screw (mm)	20	12
Motor output	100W	50W
Resolution (mm)	0.01	

Note 1: When the stroke is as given below, the maximum speed differs.

	Stroke (mm)	Maximum speed (mm/s)
X-axis	750	1000
	850	800
	950~1050	600
	1150~1250	400

Acceleration/deceleration time when the maximum speed is set: 0.36 sec. or over

Maximum payload (kg)	Y-axis stroke							
	50mm	100mm	150mm	200mm	250mm	300mm	350mm	400mm
	10.5	10.5	6.5	6.5	3.0	3.0	0.5	0.5

R: Right-handed

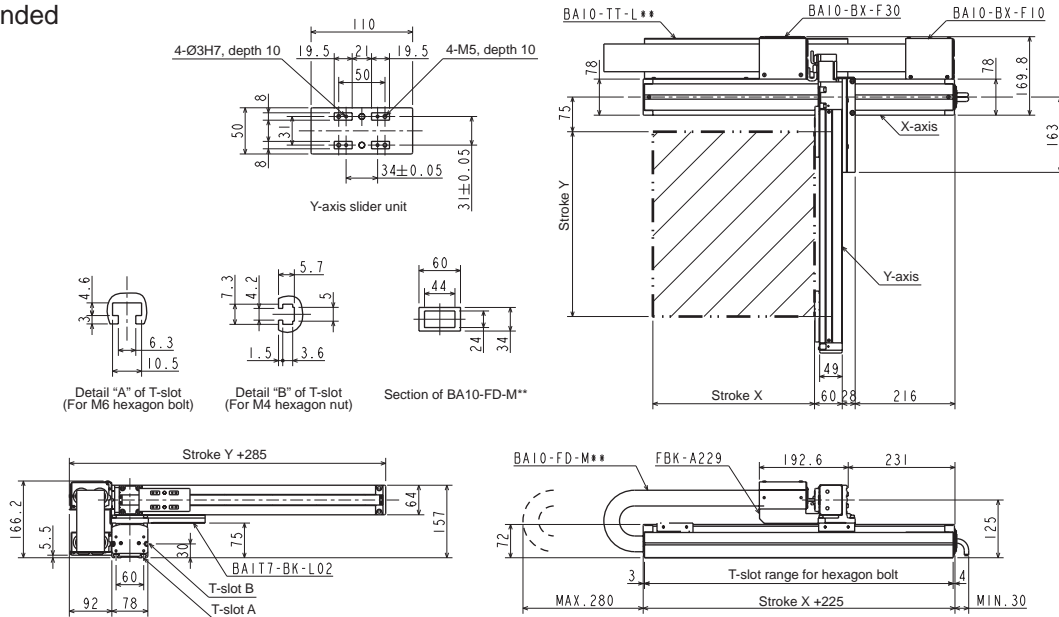

L: Left-handed

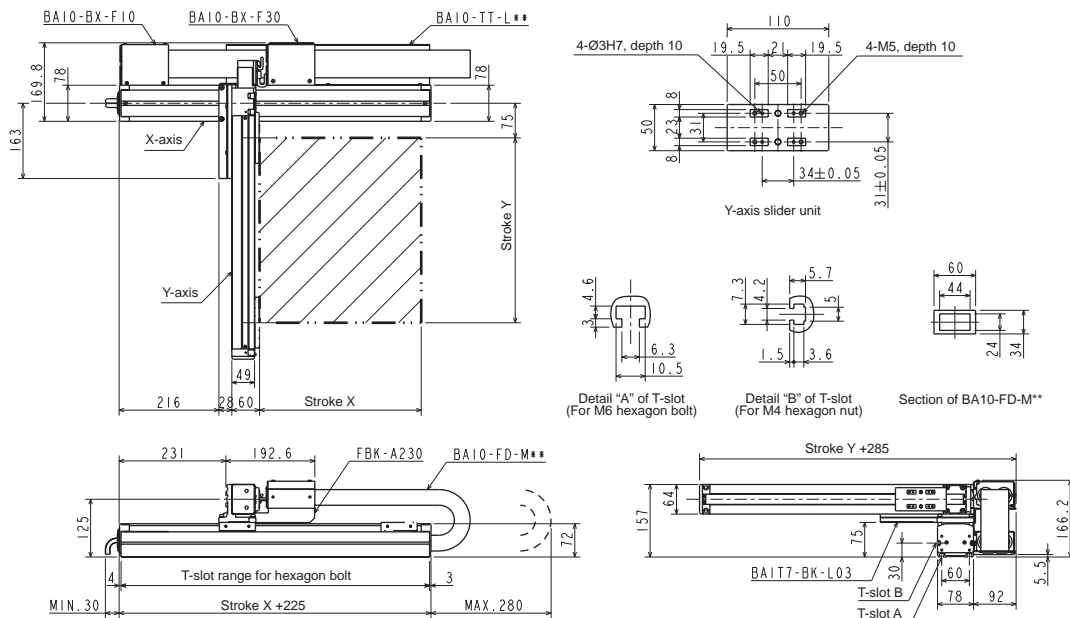

[Set designation]

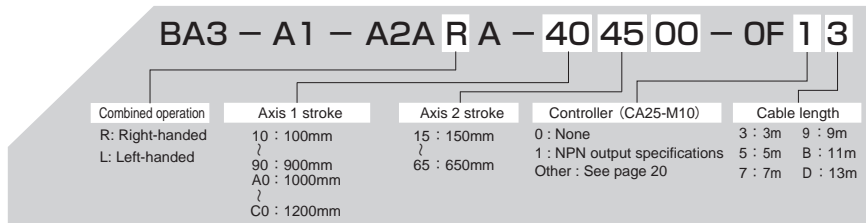

Ball screw type

X-axis: Ball screw driven
Motor straight

Y-axis: Ball screw driven
Motor straight

[Specifications]

	X-axis	Y-axis
Type of axis	BE10E-ST-M20N-□0	BE10E-ST-S20N-□5
Stroke (mm) (in increments of 100 mm for X-axis, 50 mm for Y-axis)	100 ~ 1200mm	150 ~ 650mm
Maximum speed (mm/s)	1200mm/s (Note 1)	1200mm/s
Positioning repeatability (mm)	±0.01mm	
Lead of ball screw (mm)	20mm	20mm
Motor output	100W	100W
Resolution (mm)	0.01mm	

Note 1: When the stroke is as given below, the maximum speed differs.

	Stroke (mm)	Maximum speed (mm/s)
X-axis	700	1000
	800	800
	900~1000	600
	1100~1200	400

Acceleration/deceleration time when the maximum speed is set: 0.36 sec. or over

Maximum payload (kg)	Y-axis stroke					
	150mm	250mm	350mm	450mm	550mm	650mm
	9.0	8.0	6.5	5.0	3.0	1.0

R: Right-handed

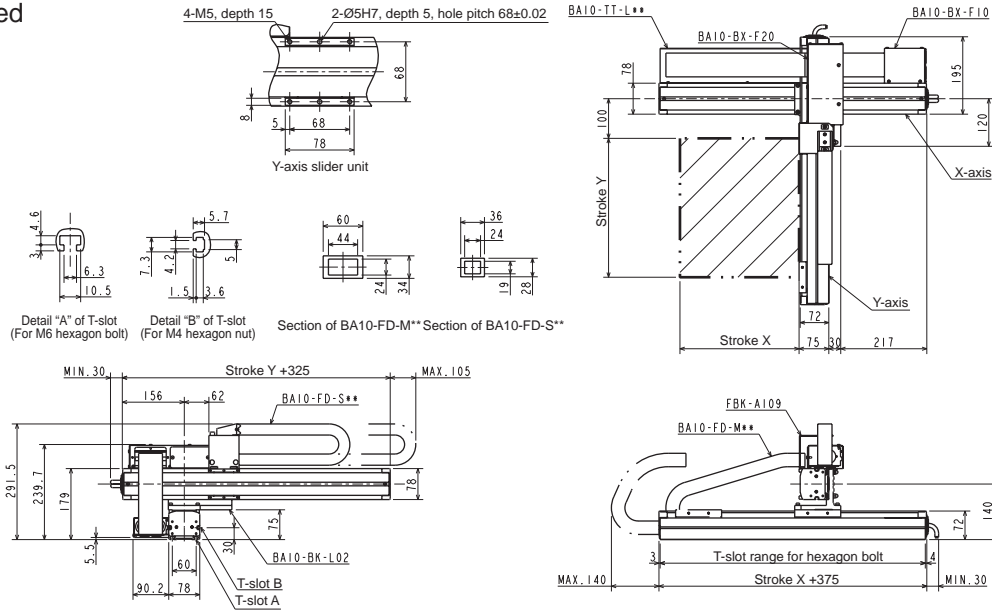

L: Left-handed

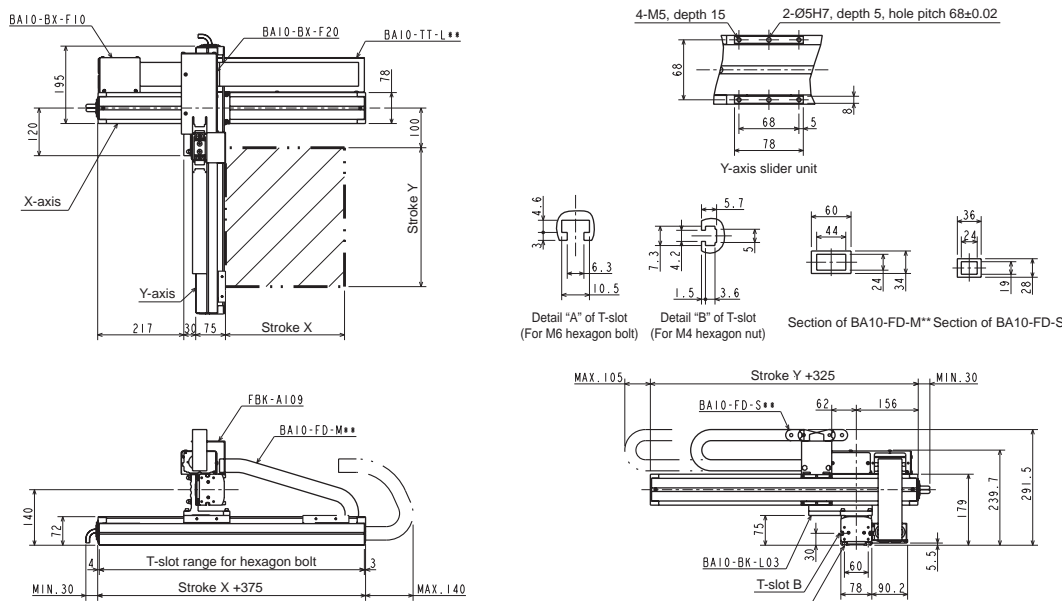

[Set designation]

BA3 - A1 - A2A RE - 40 45 00 - OF 1 3

Combined operation R: Right-handed L: Left-handed	Axis 1 stroke 10 : 100mm 90 : 900mm A0 : 1000mm C0 : 1200mm	Axis 2 stroke 15 : 150mm 65 : 650mm	Controller (CA25-M10) 0 : None 1 : NPN output specifications Other : See page 20	Cable length 3 : 3m 9 : 9m 5 : 5m B : 11m 7 : 7m D : 13m
---	---	---	---	---

Ball screw type

X-axis: Ball screw driven
Side mounted motor

Y-axis: Ball screw driven
Side mounted motor

[Specifications]

	X-axis	Y-axis
Type of axis	BE10E-U □ -M20N- □ 0	BE10E-U □ -S20N- □ 5
Stroke (in increments of 100 mm)	100 ~ 1200mm	150 ~ 650mm
Maximum speed	1200mm/s (Note 1)	1200mm/s
Positioning repeatability	± 0.01mm	
Lead of ball screw	20mm	20mm
Motor output	100W	100W
Resolution	0.01mm	

Note 1: When the stroke is as given below, the maximum speed differs.

	Stroke (mm)	Maximum speed (mm/s)
X-axis	700	1000
	800	800
	900~1000	600
	1100~1200	400

Acceleration/deceleration time when the maximum speed is set: 0.36 sec. or over

Maximum payload (kg)	Y-axis stroke					
	150mm	250mm	350mm	450mm	550mm	650mm
	9.0	8.0	6.5	5.0	3.0	1.0

R: Right-handed

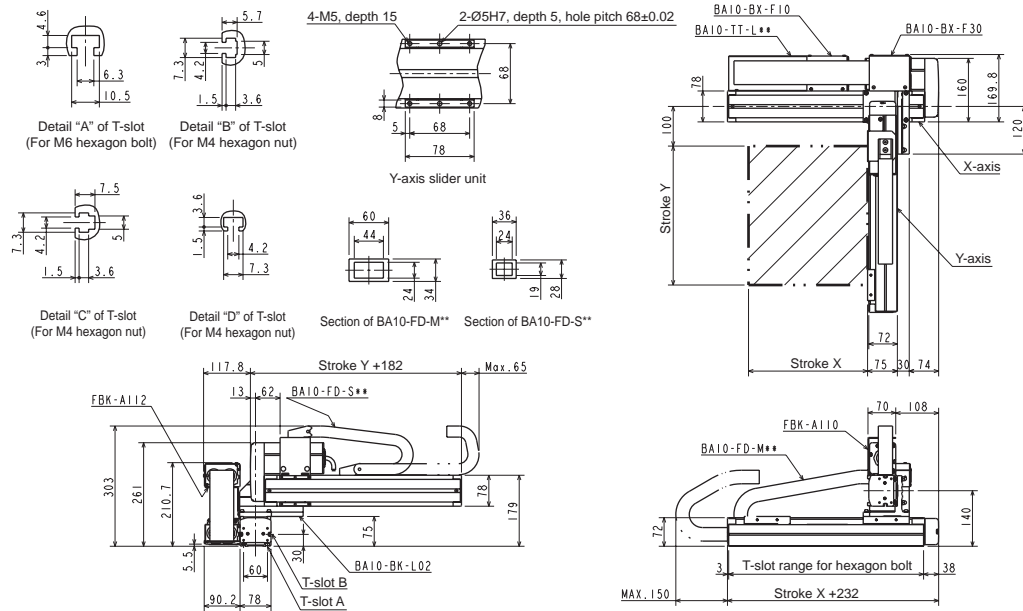

L: Left-handed

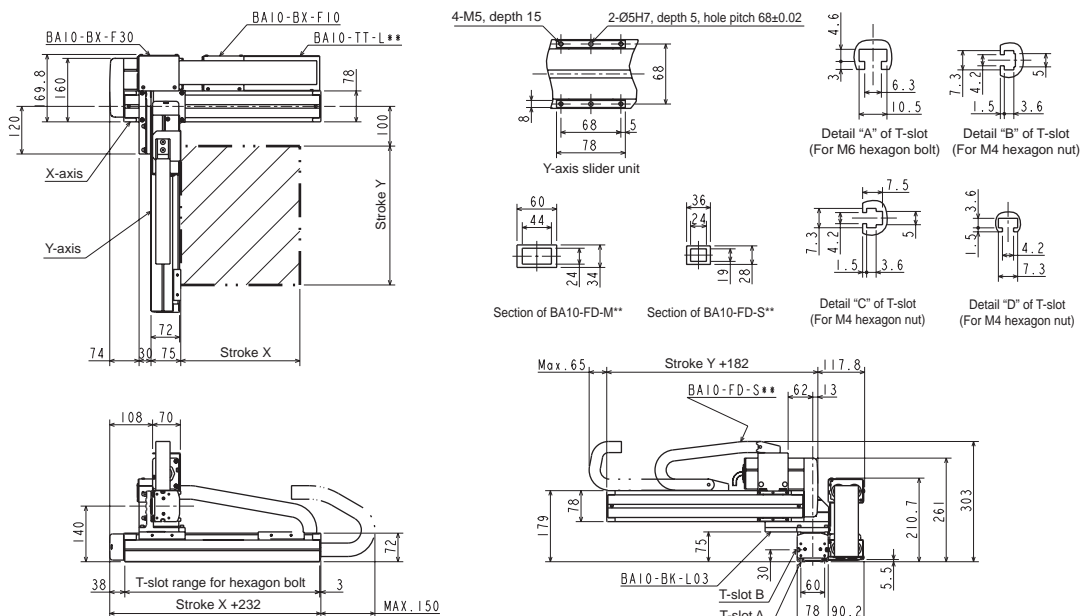

[Set designation]

BA3 - A3 - A2A R A - 45 40 00 - OF 1 3

Combined operation	Axis 1 stroke	Axis 2 stroke	Controller (CA25-M10)	Cable length
R: Right-handed L: Left-handed	15 : 150mm 95 : 950mm A5 : 1050mm C5 : 1250mm	10 : 100mm 80 : 800mm	0 : None 1 : NPN output specifications Other : See page 20	3 : 3m 9 : 9m 5 : 5m B : 11m 7 : 7m D : 13m

Ball screw type

X-axis: Ball screw driven
Motor straight

Y-axis: Ball screw driven
Motor straight

[Specifications]

	X-axis	Y-axis
Type of axis	BE30E-ST-M20N-□ 5	BE10E-ST-M20N-□ 0
Stroke (in increments of 100 mm)	150 ~ 1250mm	100 ~ 800mm
Maximum speed	1200mm/s (Note 1)	1200mm/s (Note 1)
Positioning repeatability	± 0.01mm	
Lead of ball screw	20mm	20mm
Motor output	100W	100W
Resolution	0.01mm	

Note 1: When the stroke is as given below, the maximum speed differs.

	Stroke (mm)	Maximum speed (mm/s)
X-axis	750	1000
	850	800
	950~1050	600
	1150~1250	400
Y-axis	700	1000
	800	800

Acceleration/deceleration time when the maximum speed is set: 0.48 sec. or over

Maximum payload (kg)	Y-axis stroke							
	100mm	200mm	300mm	400mm	500mm	600mm	700mm	800mm
	13.0	12.0	11.0	10.0	8.0	6.0	3.0	2.0

R: Right-handed

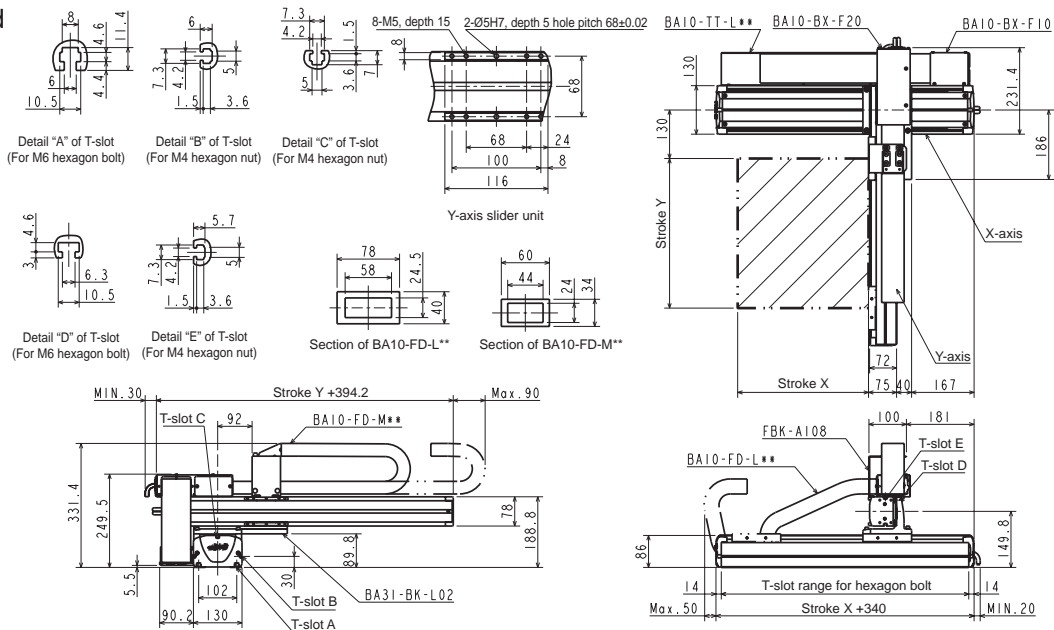

L: Left-handed

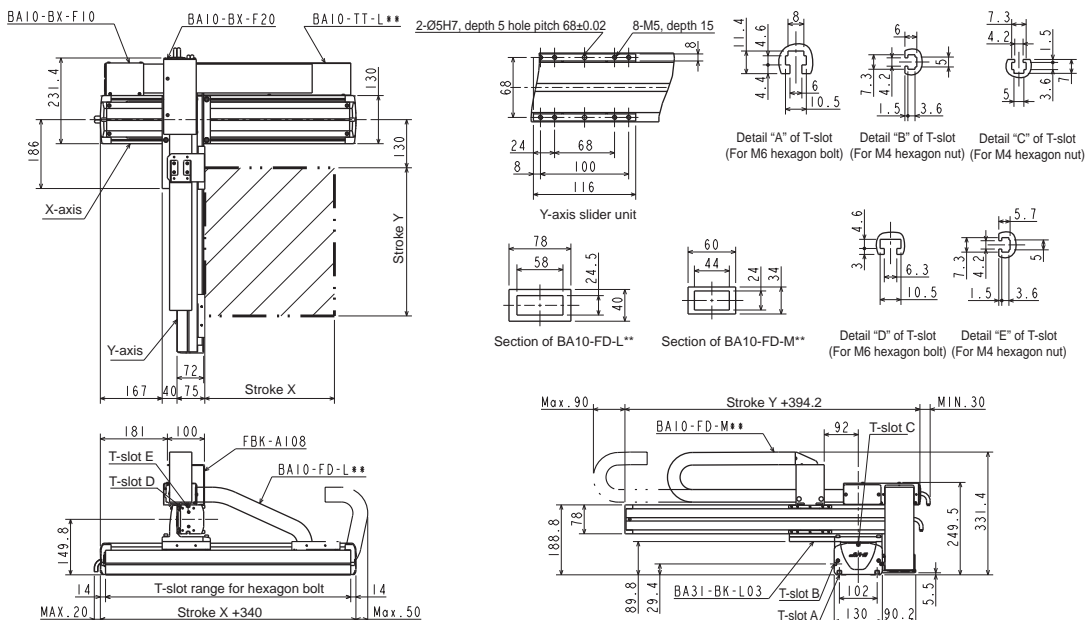

[Set designation]

BA3 - A3 - A2A R E - 40 40 00 - OF 1 3

Combined operation R: Right-handed L: Left-handed	Axis 1 stroke 10 : 100mm 90 : 900mm A0 : 1000mm C0 : 1200mm	Axis 2 stroke 10 : 100mm 80 : 800mm	Controller (CA25-M10) 0 : None 1 : NPN output specifications Other : See page 20	Cable length 3 : 3m 9 : 9m 5 : 5m B : 11m 7 : 7m D : 13m
---	---	---	---	---

Ball screw type

- X-axis: Ball screw driven
Side mounted motor
- Y-axis: Ball screw driven
Side mounted motor

[Specifications]

	X-axis	Y-axis
Type of axis	BE30E-U □ -M20N- □ 0	BE10E-U □ -M20N- □ 0
Stroke (in increments of 100 mm)	100 ~ 1200mm	100 ~ 800mm
Maximum speed	1200mm/s (Note 1)	1200mm/s (Note 1)
Positioning repeatability	± 0.01 mm	
Lead of ball screw	20mm	20mm
Motor output	100W	100W
Resolution	0.01 mm	

Note 1: When the stroke is as given below, the maximum speed differs.

	Stroke (mm)	Maximum speed (mm/s)
X-axis	700	1000
	800	800
	900~1000	600
Y-axis	1100~1200	400
	700	1000
	800	800

Acceleration/deceleration time when the maximum speed is set: 0.48 sec. or over

Maximum payload (kg)	Y-axis stroke							
	100mm	200mm	300mm	400mm	500mm	600mm	700mm	800mm
	13.0	12.0	11.0	10.0	8.0	6.0	3.0	2.0

R: Right-handed

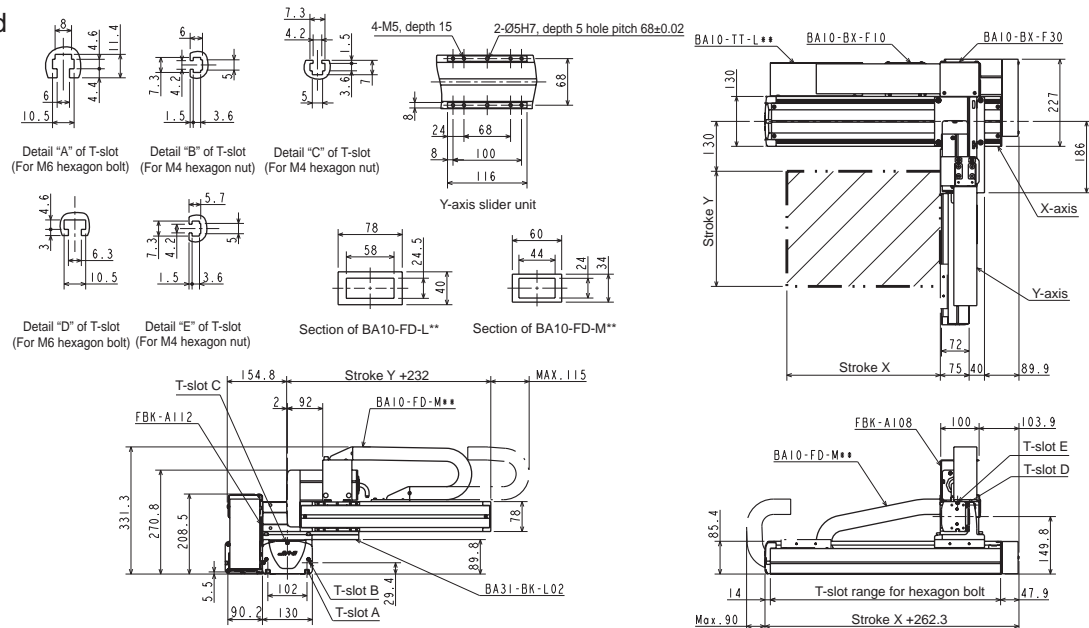

L: Left-handed

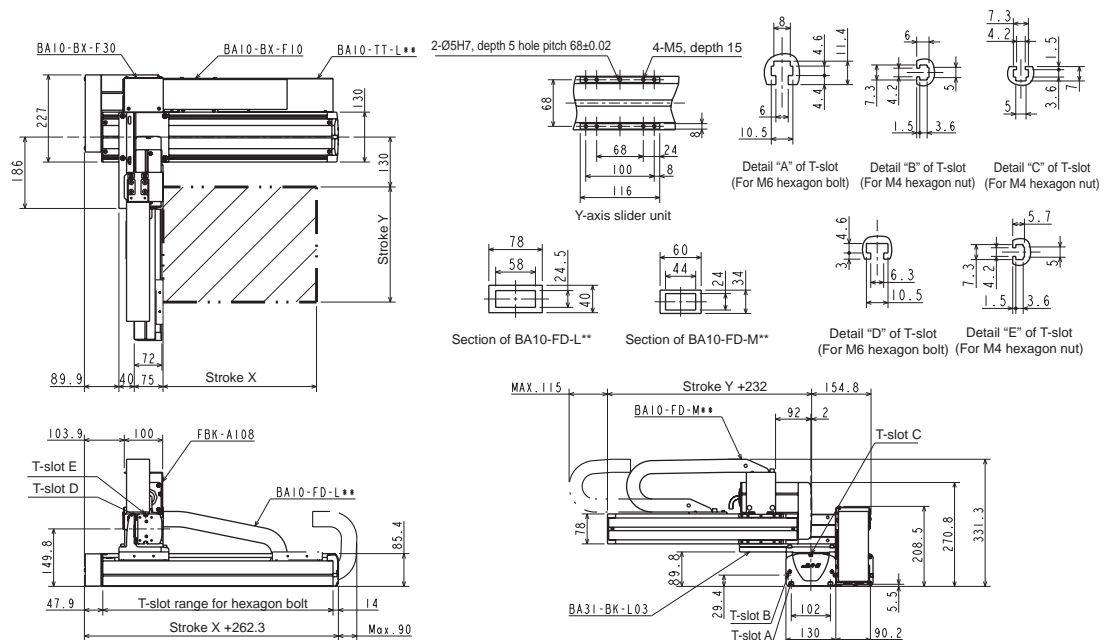

[Set designation]

BA3 - A3 - A2B R A - 40 40 00 - OF 1 3

Combined operation R: Right-handed L: Left-handed	Axis 1 stroke 10 : 100mm 90 : 900mm A0 : 1000mm C0 : 1200mm	Axis 2 stroke 10 : 100mm 80 : 800mm	Controller (CA25-M10) 0 : None 1 : NPN output specifications Other : See page 20	Cable length 3 : 3m 9 : 9m 5 : 5m B : 11m 7 : 7m D : 13m
---	---	---	---	---

Ball screw type

X-axis: Ball screw driven
Motor straight

Y-axis: Ball screw driven
Motor straight

[Specifications]

	X-axis	Y-axis
Type of axis	BE30F-ST-M20N-□ 0	BE10E-ST-M20N-□ 0
Stroke (in increments of 100 mm)	100 ~ 1200mm	100 ~ 800mm
Maximum speed	1200mm/s (Note 1)	1200mm/s (Note 1)
Positioning repeatability	± 0.01mm	
Lead of ball screw	20mm	20mm
Motor output	200W	100W
Resolution	0.01mm	

Note 1: When the stroke is as given below, the maximum speed differs.

	Stroke (mm)	Maximum speed (mm/s)
X-axis	700	1000
	800	800
	900~1000	600
	1100~1200	400
Y-axis	700	1000
	800	800

Acceleration/deceleration time when the maximum speed is set: 0.36 sec. or over

Maximum payload (kg)	Y-axis stroke							
	100mm	200mm	300mm	400mm	500mm	600mm	700mm	800mm
	15.0	15.0	14.0	11.0	8.0	6.0	4.0	2.0

R: Right-handed

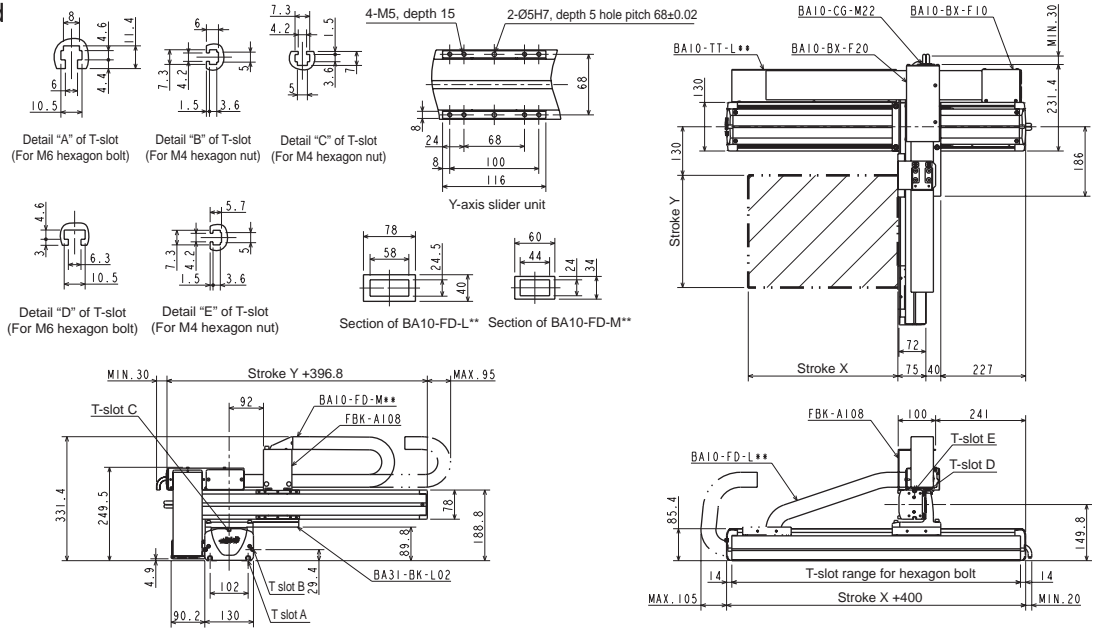

L: Left-handed

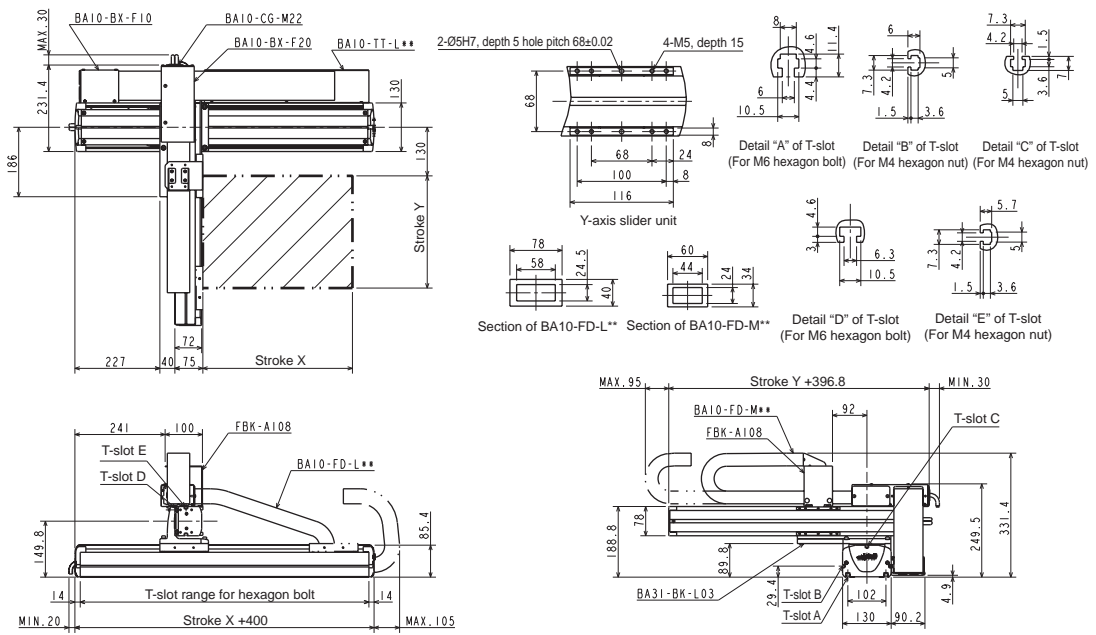

X-Y Flexible-duct Spec.

[Set designation]

BA3 - A3 - A2B R E - 40 40 00 - OF 1 3

Combined operation R: Right-handed L: Left-handed	Axis 1 stroke 10 : 100mm 90 : 900mm A0 : 1000mm C0 : 1200mm	Axis 2 stroke 10 : 100mm 80 : 800mm	Controller (CA25-M10) 0 : None 1 : NPN output specifications Other : See page 20	Cable length 3 : 3m 9 : 9m 5 : 5m B : 11m 7 : 7m D : 13m
---	---	---	---	---

Ball screw type

X-axis: Ball screw driven
Side mounted motor

Y-axis: Ball screw driven
Side mounted motor

[Specifications]

	X-axis	Y-axis
Type of axis	BE30F-U □ -M20N- □ 0	BE10E-U □ -M20N- □ 0
Stroke (in increments of 100 mm)	100 ~ 1200mm	100 ~ 800mm
Maximum speed	1200mm/s (Note 1)	1200mm/s (Note 1)
Positioning repeatability	± 0.01mm	
Lead of ball screw	20mm	20mm
Motor output	200W	100W
Resolution	0.01mm	

Acceleration/deceleration time when the maximum speed is set: 0.36 sec. or over

Note 1: When the stroke is as given below, the maximum speed differs.

	Stroke (mm)	Maximum speed (mm/s)
X-axis	700	1000
	800	800
	900~1000	600
Y-axis	1100~1200	400
	700	1000
	800	800

Maximum payload (kg)	Y-axis stroke							
	100mm	200mm	300mm	400mm	500mm	600mm	700mm	800mm
	15.0	15.0	14.0	11.0	8.0	6.0	4.0	2.0

R: Right-handed

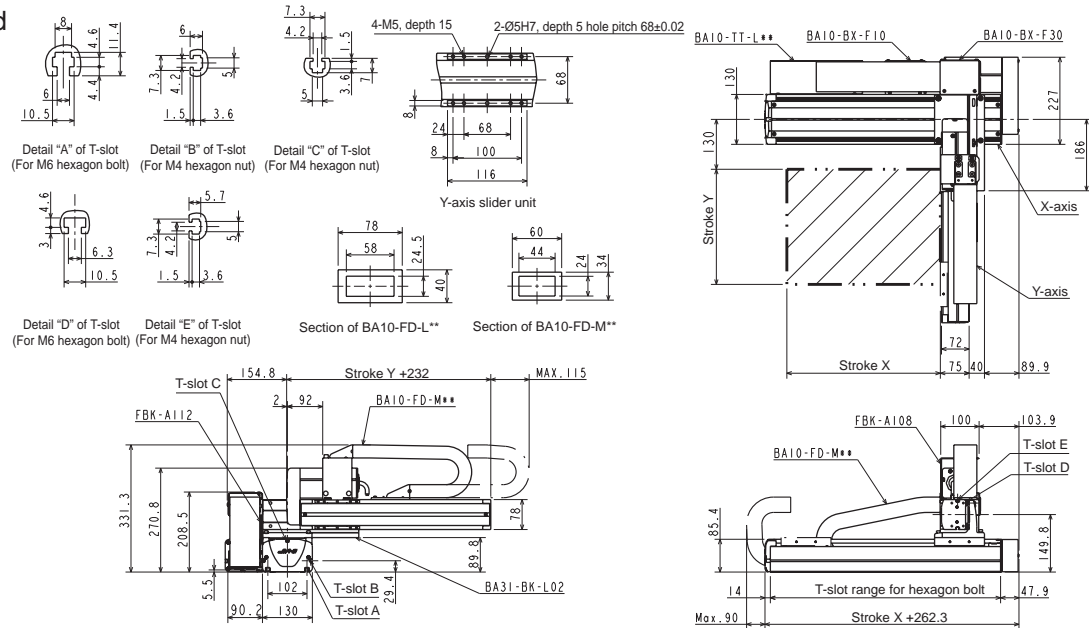

L: Left-handed

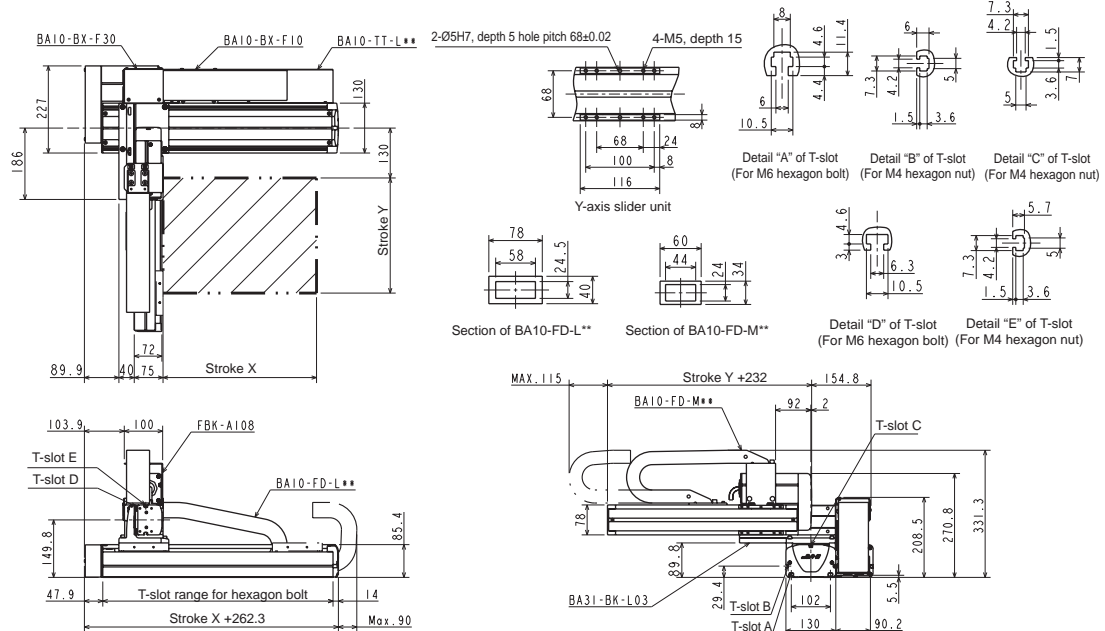

[Set designation]

BA3 - A5 - A2A R A - 40 45 00 - OF 1 3

Combined operation R: Right-handed L: Left-handed	Axis 1 stroke 20 : 200mm 90 : 900mm A0 : 1000mm G0 : 1600mm	Axis 2 stroke 15 : 150mm 95 : 950mm A5 : 1050mm	Controller (CA25-M10) 0 : None 1 : NPN output specifications Other : See page 20	Cable length 3 : 3m 9 : 9m 5 : 5m B : 11m 7 : 7m D : 13m
---	---	--	---	---

Ball screw type

X-axis: Ball screw driven
Motor straight

Y-axis: Ball screw driven
Motor straight

Note 1: When the stroke is as given below, the maximum speed differs.

[Specifications]

	X-axis	Y-axis
Type of axis	BE50F-ST-M20N-□ 0	BE30E-ST-M20N-□ 5
Stroke (in increments of 100 mm)	200 ~ 1600mm	150 ~ 1050mm
Maximum speed	1200mm/s (Note 1)	1200mm/s (Note 1)
Positioning repeatability	±0.01mm	
Lead of ball screw	20mm	20mm
Motor output	200W	100W
Resolution	0.01mm	

Acceleration/deceleration time when the maximum speed is set: 0.36 sec. or over

	Stroke (mm)	Maximum speed (mm/s)
X-axis	700~800	1100
	900~1000	1000
	1100~1200	700
	1300	500
	1400	400
	1500	300
Y-axis	1600	300
	750	1000
	850	800
	950~1050	600

Maximum payload (kg)	Y-axis stroke									
	150mm	250mm	350mm	450mm	550mm	650mm	750mm	850mm	950mm	1050mm
	20.0	20.0	20.0	20.0	20.0	20.0	19.0	17.0	14.0	11.0

R: Right-handed

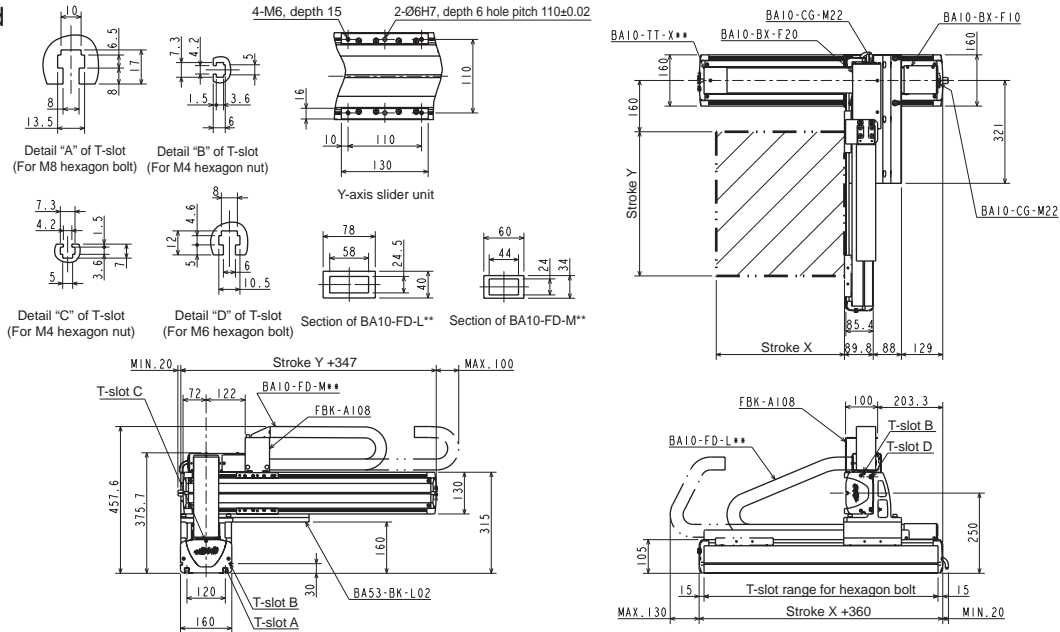

L: Left-handed

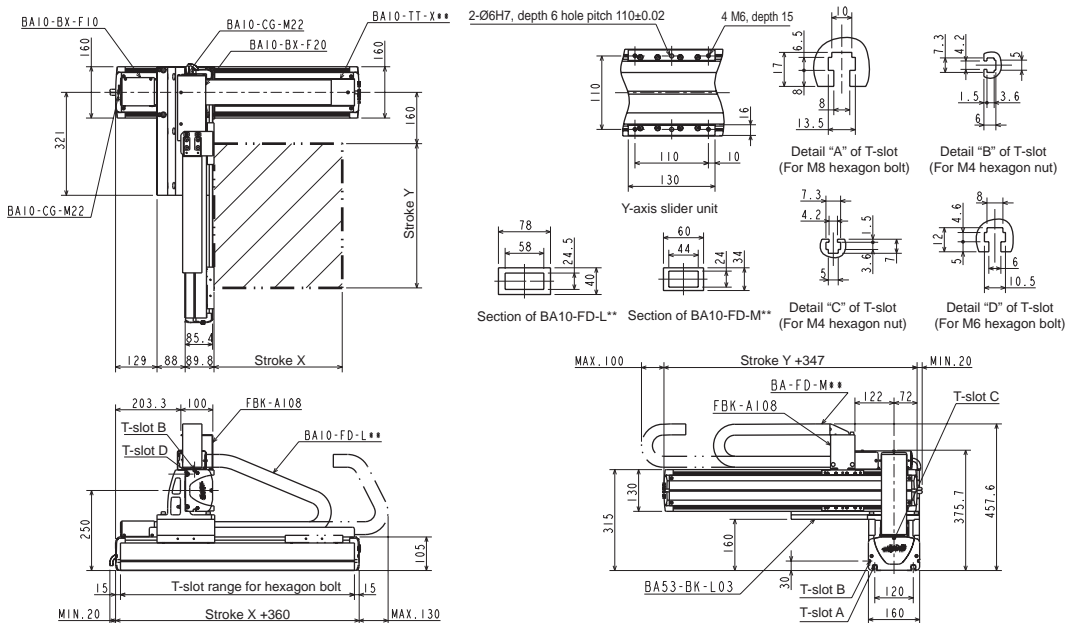

X-Y Flexible-duct Spec.

[Set designation]

BA3 - A5 - A2A R G - 40 45 00 - OF 1 3

Combined operation R: Right-handed L: Left-handed	Axis 1 stroke 20 : 200mm 90 : 900mm A0 : 1000mm G0 : 1600mm	Axis 2 stroke 15 : 150mm 95 : 950mm A5 : 1050mm	Controller (CA25-M10) 0 : None 1 : NPN output specifications Other : See page 20	Cable length 3 : 3m 9 : 9m 5 : 5m B : 11m 7 : 7m D : 13m
---	---	--	---	---

Ball screw type

X-axis: Ball screw driven
Side mounted motor

Y-axis: Ball screw driven
Motor straight

Note 1: When the stroke is as given below, the maximum speed differs.

[Specifications]

	X-axis	Y-axis
Type of axis	BE50F-U □ -M20N- □ 0	BE30E-ST-M20N- □ 5
Stroke (in increments of 100 mm)	200 ~ 1600mm	150 ~ 1050mm
Maximum speed	1200mm/ s (Note 1)	1200mm/ s (Note 1)
Positioning repeatability	± 0.01mm	
Lead of ball screw	20mm	20mm
Motor output	200W	100W
Resolution	0.01mm	

Acceleration/deceleration time when the maximum speed is set: 0.36 sec. or over

	Stroke (mm)	Maximum speed (mm/s)
X-axis	700~800	1100
	900~1000	1000
	1100~1200	700
	1300	500
	1400	400
	1500	300
Y-axis	1600	300
	750	1000
	850	800
	950~1050	600

Maximum payload (kg)	Y-axis stroke									
	150mm	250mm	350mm	450mm	550mm	650mm	750mm	850mm	950mm	1050mm
	20.0	20.0	20.0	20.0	20.0	20.0	19.0	17.0	14.0	11.0

R: Right-handed

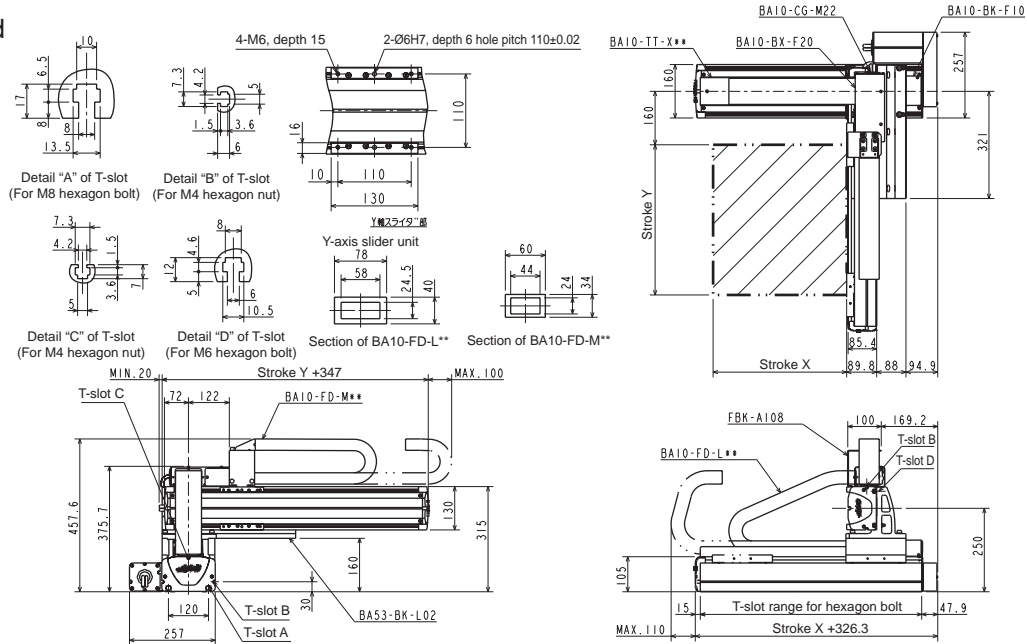

L: Left-handed

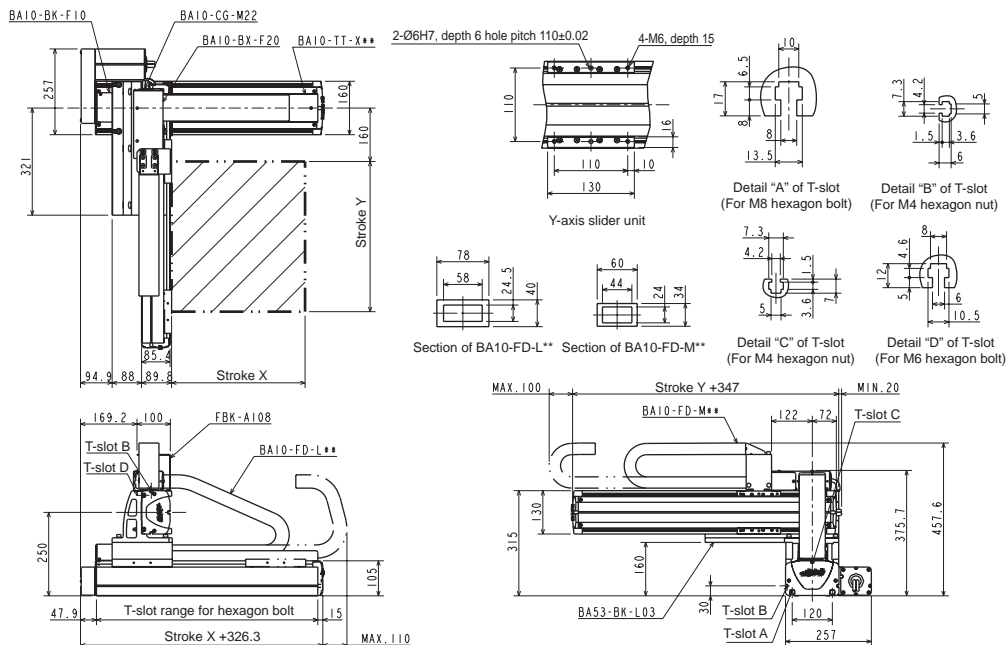

[Set designation]

BA3 - A5 - A2B R A - 40 40 00 - OF 1 3

Combined operation	Axis 1 stroke	Axis 2 stroke	Controller (CA25-M10)	Cable length
R: Right-handed	20 : 200mm	10 : 100mm	0 : None	3 : 3m 9 : 9m
L: Left-handed	90 : 900mm	90 : 900mm	1 : NPN output specifications	5 : 5m B : 11m
	A0 : 1000mm	A0 : 1000mm	Other : See page 20	7 : 7m D : 13m
	G0 : 1600mm			

Ball screw type

X-axis: Ball screw driven
Motor straight

Y-axis: Ball screw driven
Motor straight

Note 1: When the stroke is as given below, the maximum speed differs.

[Specifications]

	X-axis	Y-axis
Type of axis	BE50F-ST-M20N-□ 0	BE30F-ST-M20N-□ 0
Stroke (in increments of 100 mm)	200 ~ 1600mm	100 ~ 1000mm
Maximum speed	1200mm/s (Note 1)	1200mm/s (Note 1)
Positioning repeatability	±0.01mm	
Lead of ball screw	20mm	20mm
Motor output	200W	200W
Resolution	0.01mm	

Acceleration/deceleration time when the maximum speed is set: 0.36 sec. or over

	Stroke (mm)	Maximum speed (mm/s)
X-axis	700~800	1100
	900~1000	1000
	1100~1200	700
	1300	500
	1400	400
	1500	300
Y-axis	1600	300
	700	1000
	800	800
	900~1000	600

Maximum payload (kg)	Y-axis stroke									
	100mm	200mm	300mm	400mm	500mm	600mm	700mm	800mm	900mm	1000mm
	40.0 (31.0)	40.0 (30.0)	33.0 (29.0)	31.0 (28.0)	27.0	23.0	20.0	17.0	14.0	12.0

When the X-axis speed exceeds 1,000 mm/s, the values in parentheses are used for the maximum payload.

R: Right-handed

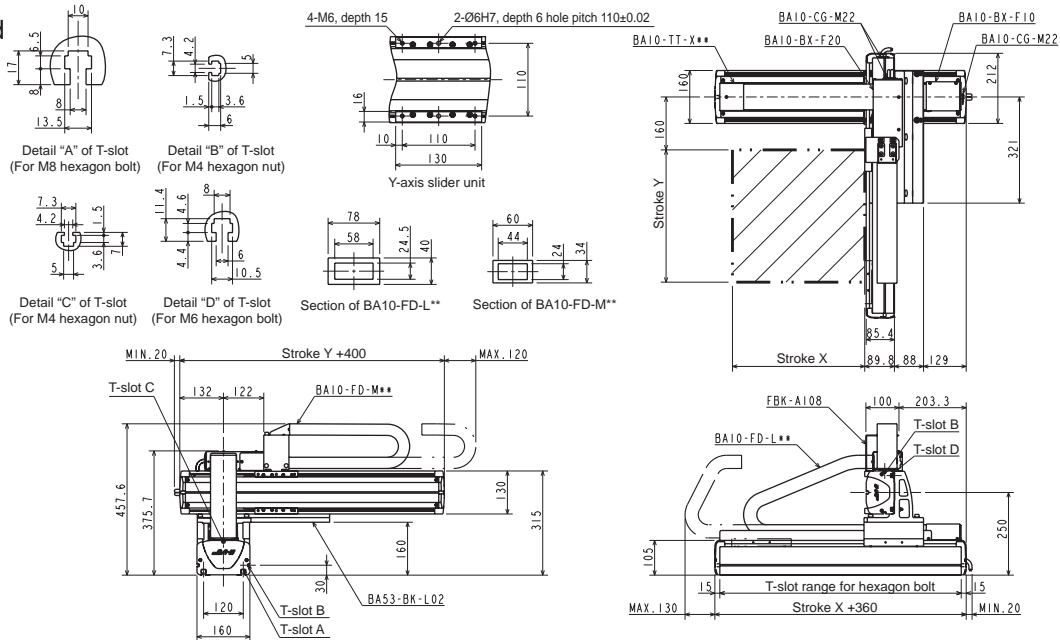

L: Left-handed

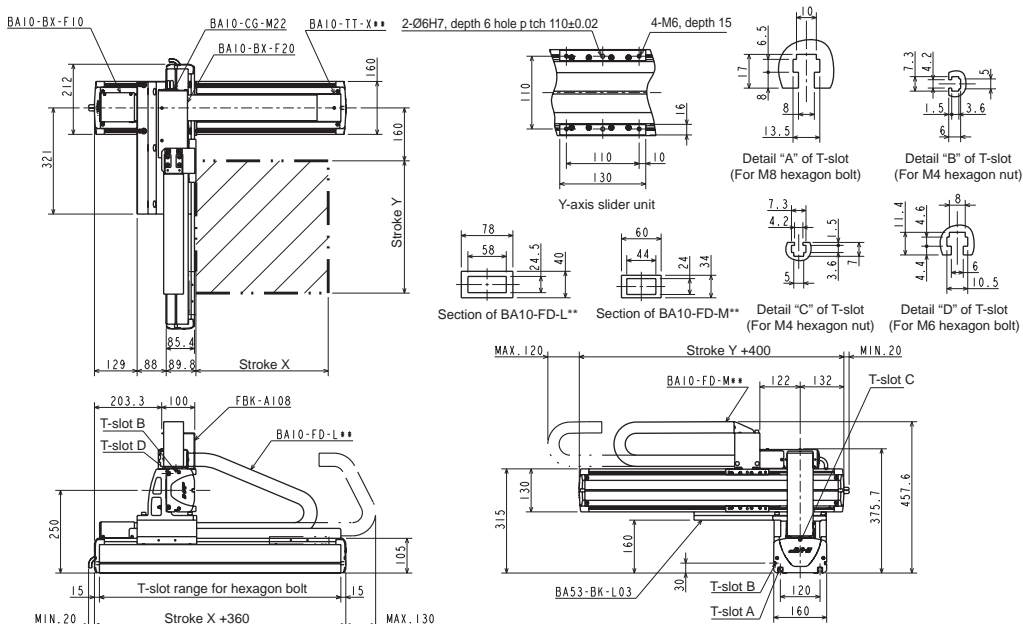

[Set designation]

BA3 - A5 - A2B R G - 40 40 00 - OF 1 3

Combined operation R: Right-handed L: Left-handed	Axis 1 stroke 20 : 200mm 90 : 900mm A0 : 1000mm G0 : 1600mm	Axis 2 stroke 10 : 100mm 90 : 900mm A0 : 1000mm	Controller (CA25-M10) 0 : None 1 : NPN output specifications Other : See page 20	Cable length 3 : 3m 9 : 9m 5 : 5m B : 11m 7 : 7m D : 13m
---	---	--	---	---

Ball screw type

X-axis: Ball screw driven
Side mounted motor

Y-axis: Ball screw driven
Motor straight

Note 1: When the stroke is as given below, the maximum speed differs.

[Specifications]

	X-axis	Y-axis
Type of axis	BE50F-U □ -M20N- □ 0	BE30F-ST-M20N- □ 0
Stroke (in increments of 100 mm)	200 ~ 1600mm	100 ~ 1000mm
Maximum speed	1200mm/s (Note 1)	1200mm/s (Note 1)
Positioning repeatability	± 0.01mm	
Lead of ball screw	20mm	20mm
Motor output	200W	200W
Resolution	0.01mm	

Acceleration/deceleration time when the maximum speed is set: 0.36 sec. or over

	Stroke (mm)	Maximum speed (mm/s)
X-axis	700~800	1100
	900~1000	1000
	1100~1200	700
	1300	500
	1400	400
	1500	300
Y-axis	1600	300
	700	1000
	900~1000	600

Maximum payload (kg)	Y-axis stroke									
	100mm	200mm	300mm	400mm	500mm	600mm	700mm	800mm	900mm	1000mm
	40.0 (31.0)	40.0 (30.0)	33.0 (29.0)	31.0 (28.0)	27.0	23.0	20.0	17.0	14.0	12.0

When the X-axis speed exceeds 1,000 mm/s, the values in parentheses are used for the maximum payload.

R: Right-handed

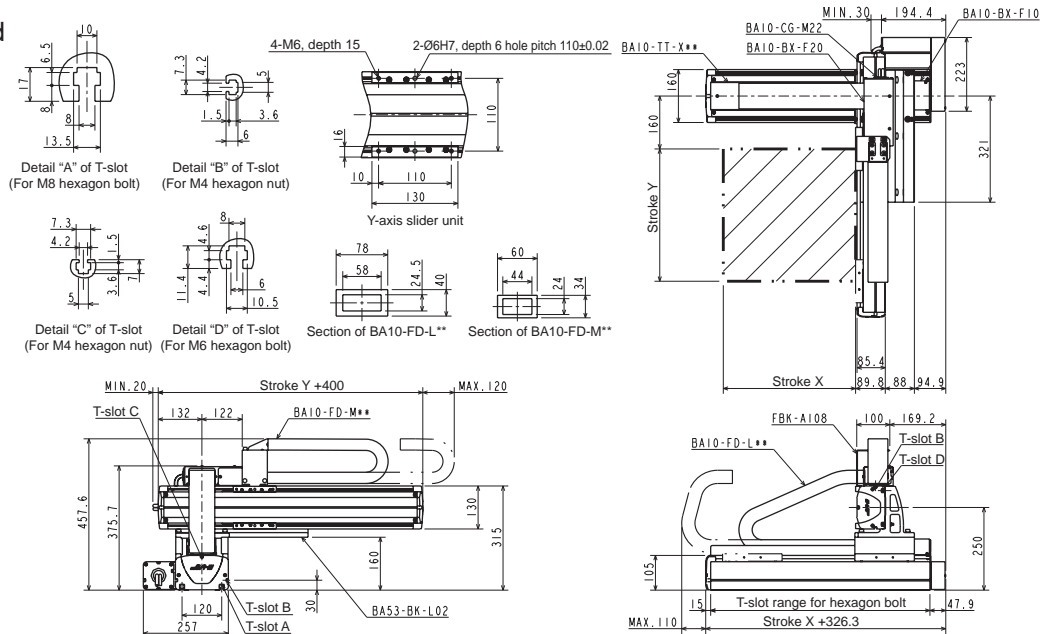

L: Left-handed

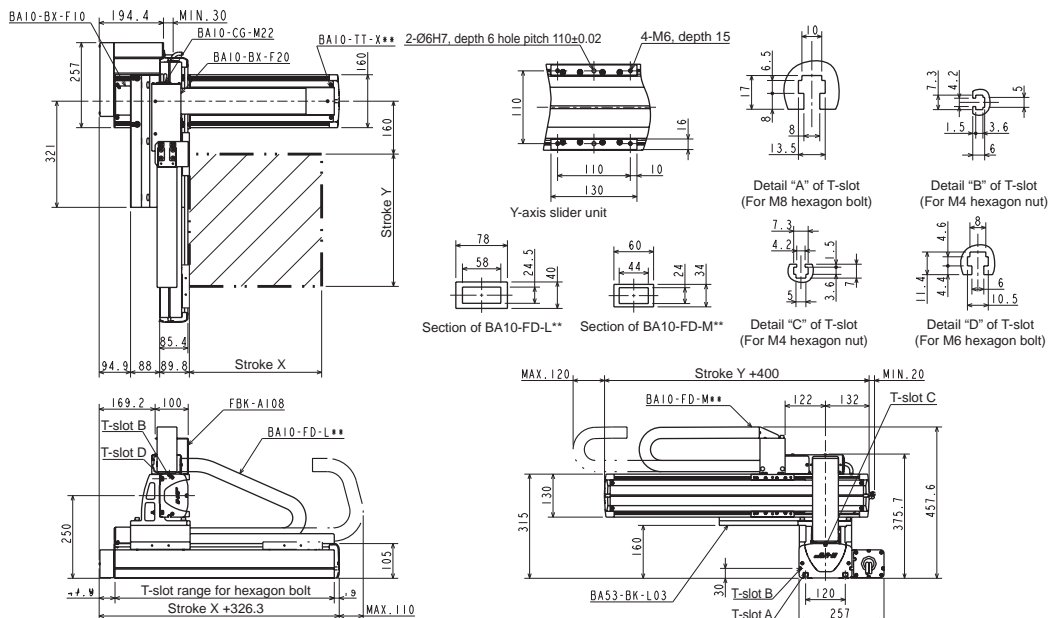

[Set designation]

BA3 - A5 - A2 F R A - 40 40 00 - OF 1 3

Combined operation R: Right-handed L: Left-handed	Axis 1 stroke 20 : 200mm 90 : 900mm A0 : 1000mm G0 : 1600mm	Axis 2 stroke 20 : 200mm 90 : 900mm A0 : 1000mm	Controller (CA25-M40) 0 : None 1 : NPN output specifications Other : See page 20	Cable length 3 : 3m 9 : 9m 5 : 5m B : 11m 7 : 7m D : 13m
---	---	--	---	---

Ball screw type

X-axis: Ball screw driven
Motor straight

Y-axis: Ball screw driven
Motor straight

Note 1: When the stroke is as given below, the maximum speed differs.

[Specifications]

	X-axis	Y-axis
Type of axis	BE50G-ST-M20N-□ 0	BE50F-ST-M20N-□ 0
Stroke (mm) (in increments of 100 mm)	200 ~ 1600	200 ~ 1000
Maximum speed (mm/s)	1200 (Note 1)	1200 (Note 1)
Positioning repeatability (mm)	± 0.01	
Lead of ball screw (mm)	20	20
Motor output	400W	200W
Resolution (mm)	0.01	

	Stroke (mm)	Maximum speed (mm/s)
X-axis	700~800	1100
	900~1000	1000
	1100~1200	700
	1300	500
	1400	400
	1500	300
Y-axis	1600	300
	700~800	1100
	900~1000	1000

Acceleration/deceleration time when the maximum speed is set: 0.36 sec. or over

Maximum payload (kg)	Y-axis stroke								
	200mm	300mm	400mm	500mm	600mm	700mm	800mm	900mm	1000mm
	60.0 (50.0)	53.5 (50.0)	45.0	38.0	32.5	27.5	23.0	19.0	13.0

The regenerative discharge unit ABSU-4000 is required for X-axis.
When the X-axis speed exceeds 1,000 mm/s, the values in parentheses are used for the maximum payload.

R: Right-handed

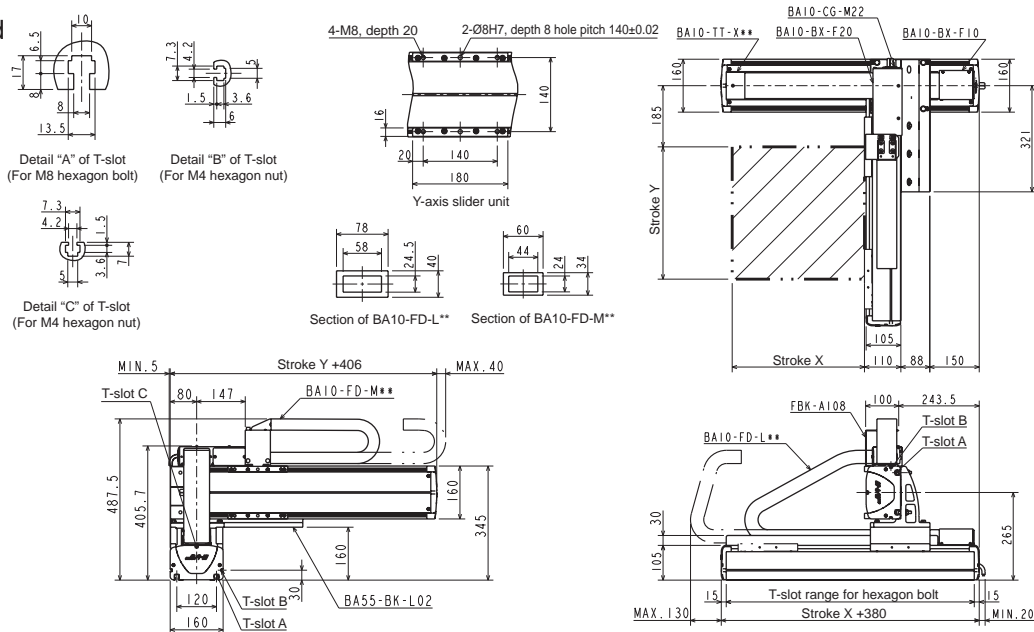

L: Left-handed

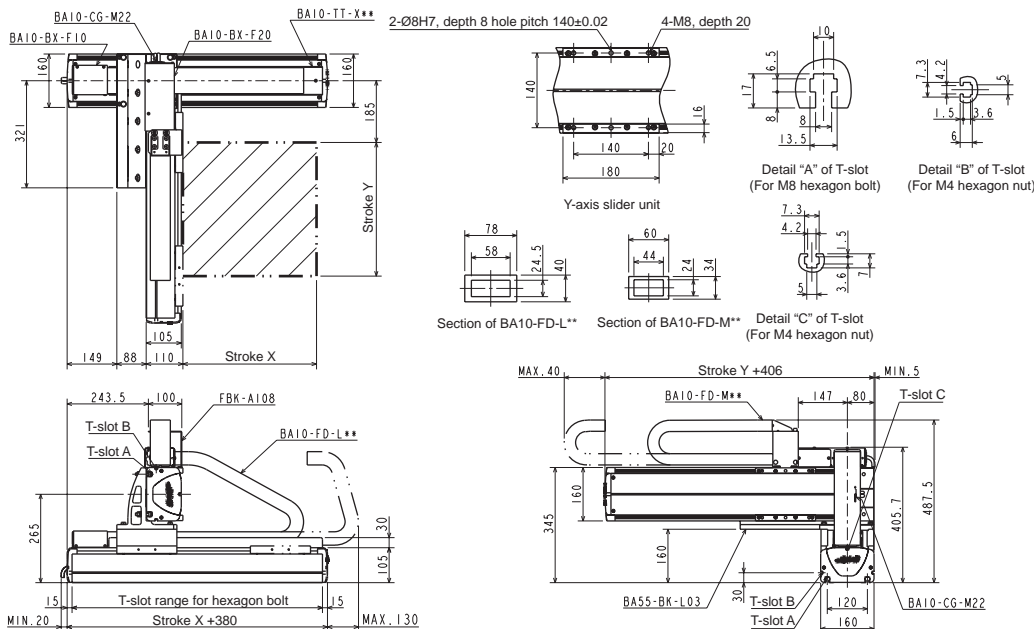

[Set designation]

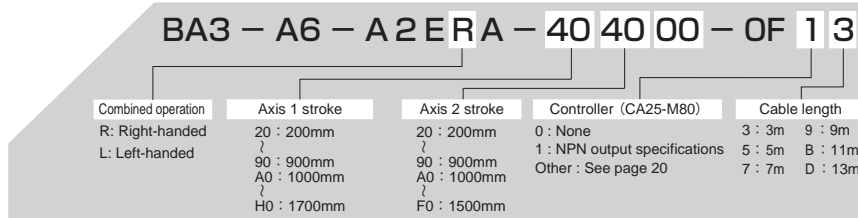

Ball screw type

X-axis: Ball screw driven
Motor straight

Y-axis: Ball screw driven
Motor straight

Note 1: When the stroke is as given below, the maximum speed differs.

[Specifications]

	X-axis	Y-axis
Type of axis	BE60J-ST-M20N- □ 0	BE50G-ST-M20N- □ 0
Stroke (mm) (in increments of 100 mm)	200 ~ 1700	200 ~ 1500
Maximum speed (mm/s)	900 (Note 1)	1200 (Note 1)
Positioning repeatability (mm)	± 0.01	
Lead of ball screw (mm)	20	20
Motor output	750W	400W
Resolution (mm)	0.01	

	Stroke (mm)	Maximum speed (mm/s)
X-axis	1100	700
	1200	600
	1300	500
	1400~1500	400
	1600~1700	300
Y-axis	700~800	1100
	900~1000	1000
	1100~1200	700
	1300	500
	1400	400
	1500	300

Acceleration/deceleration time when the maximum speed is set: 0.36 sec. or over

Maximum payload (kg)	Y-axis stroke														
	200mm	300mm	400mm	500mm	600mm	700mm	800mm	900mm	1000mm	1100mm	1200mm	1300mm	1400mm	1500mm	
	100.0	100.0	89.0	77.5	68.0	60.0	53.0	47.0	42.0	33.0	26.0	21.0	17.0	14.0	

Regenerative discharge units are required for all axes.

- 1) X-axis: Regenerative discharge unit Model: ABSU-8000
- 2) Y-axis: Regenerative discharge unit Model: ABSU-4000

R: Right-handed

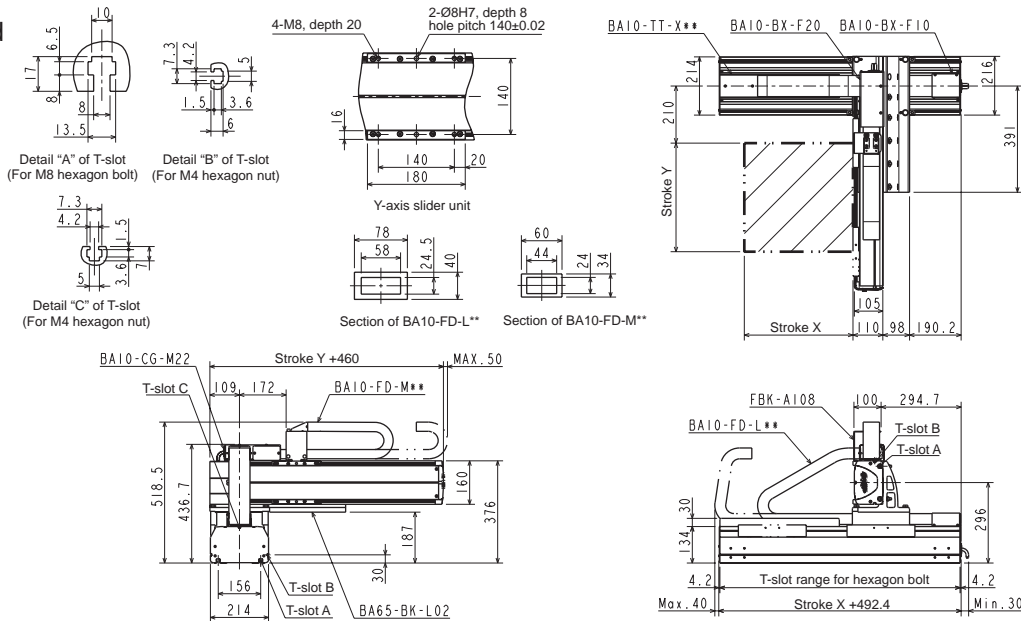

L: Left-handed

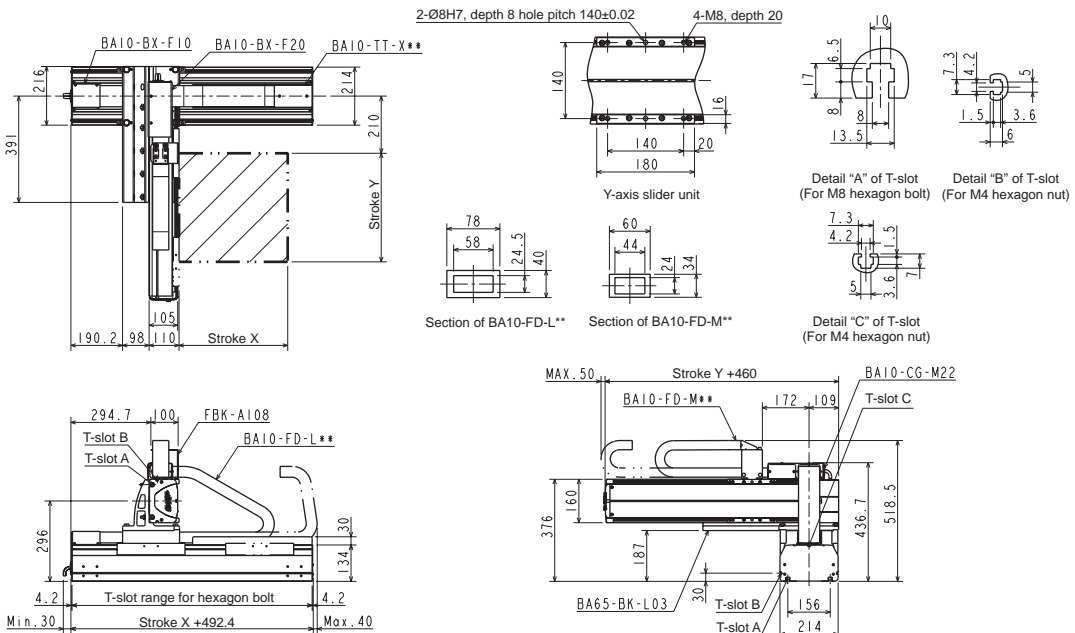

[Set designation]

BA3 - L1 - A2A RC - 40 45 00 - OF 1 3

Combined operation R: Right-handed L: Left-handed	Axis 1 stroke 10 : 100mm 90 : 900mm A0 : 1000mm H0 : 1700mm	Axis 2 stroke 15 : 150mm 65 : 650mm	Controller (CA25-M10) 0 : None 1 : NPN output specifications Other : See page 20	Cable length 3 : 3m 5 : 5m 7 : 7m	9 : 9m B : 11m D : 13m
	J0 : 1800mm N0 : 2200mm P0 : 2300mm R0 : 2500mm				

Timing belt type

- X-axis: Timing belt driven
Side mounted motor
- Y-axis: Timing belt driven
Side mounted motor

[Specifications]

	X-axis	Y-axis
Type of axis	BE10E-BT-M21N-□ 0	BE10E-B□ -S21N-□ 5
Stroke (in increments of 100 mm)	100 ~ 2500mm	150 ~ 650mm
Maximum speed	1000mm/ s	1000mm/ s
Positioning repeatability	± 0.04mm	
Lead	21 mm	21 mm
Motor output	100W	100W
Resolution	0.01mm	

Acceleration/deceleration time when the maximum speed is set: 0.4 sec. or over

Maximum payload (kg)	Y-axis stroke					
	150mm	250mm	350mm	450mm	550mm	650mm
	8.0	8.0	6.0	5.0	3.0	1.0

R: Right-handed

The values in parentheses are applicable when the X-axis stroke is 1,050 mm or over.

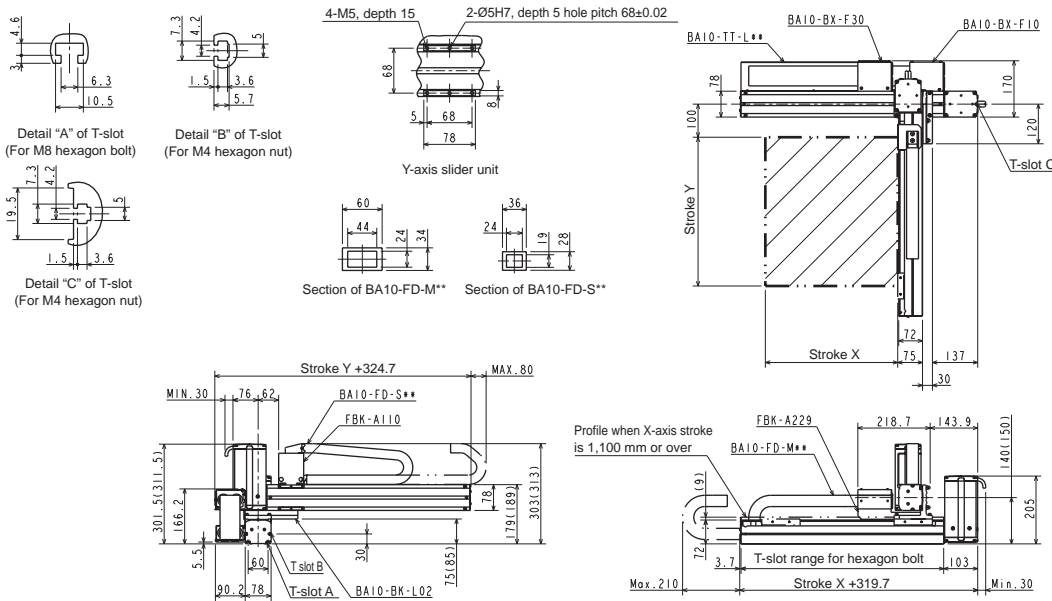

L: Left-handed

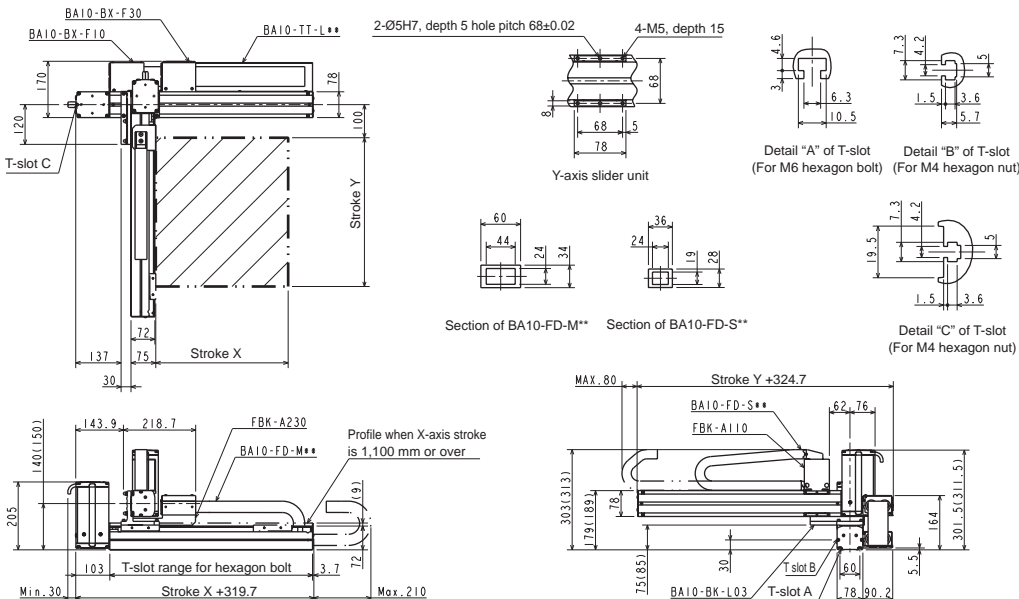

[Set designation]

BA3 - L1 - A2B RC - 40 45 00 - OF 1 3

Combined operation R: Right-handed L: Left-handed	Axis 1 stroke 10: 100mm 90: 900mm A0: 1000mm H0: 1700mm	Axis 2 stroke J0: 1800mm N0: 2200mm P0: 2300mm R0: 2500mm	Axis 2 stroke 15: 150mm 65: 650mm	Controller (CA25-M10) 0: None 1: NPN output specifications Other: See page 20	Cable length 3: 3m 5: 5m 7: 7m 9: 9m B: 11m D: 13m
---	---	---	---	--	--

Timing belt type

X-axis: Timing belt driven
Side mounted motor

Y-axis: Timing belt driven
Side mounted motor

[Specifications]

	X-axis	Y-axis
Type of axis	BE10F-BT-M21N-□ 0	BE10E-B□ -S21N-□ 5
Stroke (in increments of 100 mm)	100 ~ 2500mm	150 ~ 650mm
Maximum speed	1000mm/ s	1000mm/ s
Positioning repeatability	± 0.04mm	
Lead	21mm	21mm
Motor output	200W	100W
Resolution	0.01mm	

Acceleration/deceleration time when the maximum speed is set: 0.3 sec. or over

Maximum payload (kg)	Y-axis stroke					
	150mm	250mm	350mm	450mm	550mm	650mm
	9.0	8.0	6.0	5.0	3.0	1.0

R: Right-handed

The values in parentheses are applicable when the X-axis stroke is 1,050 mm or over.

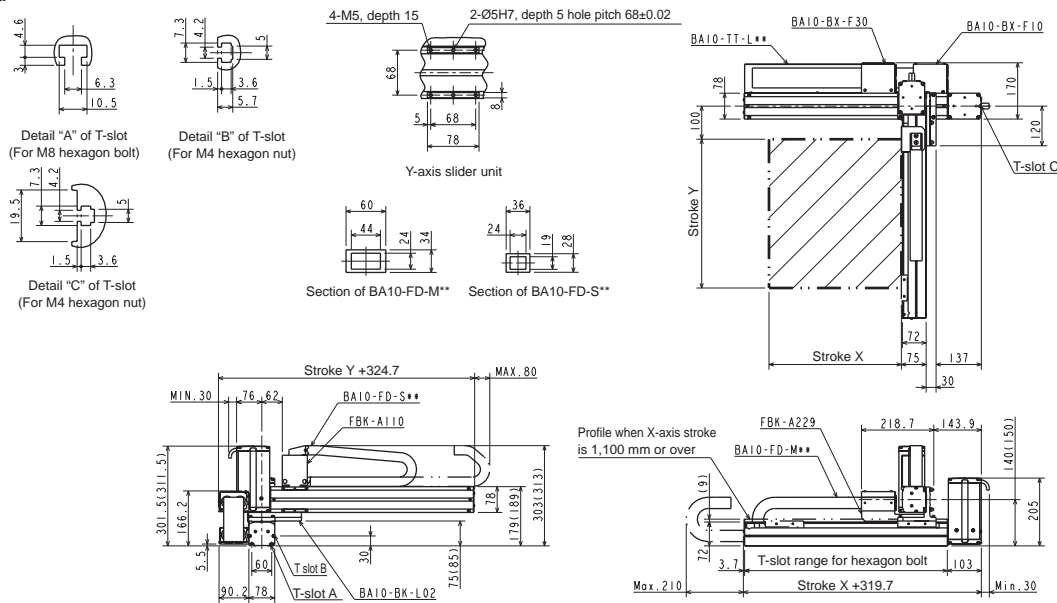

L: Left-handed

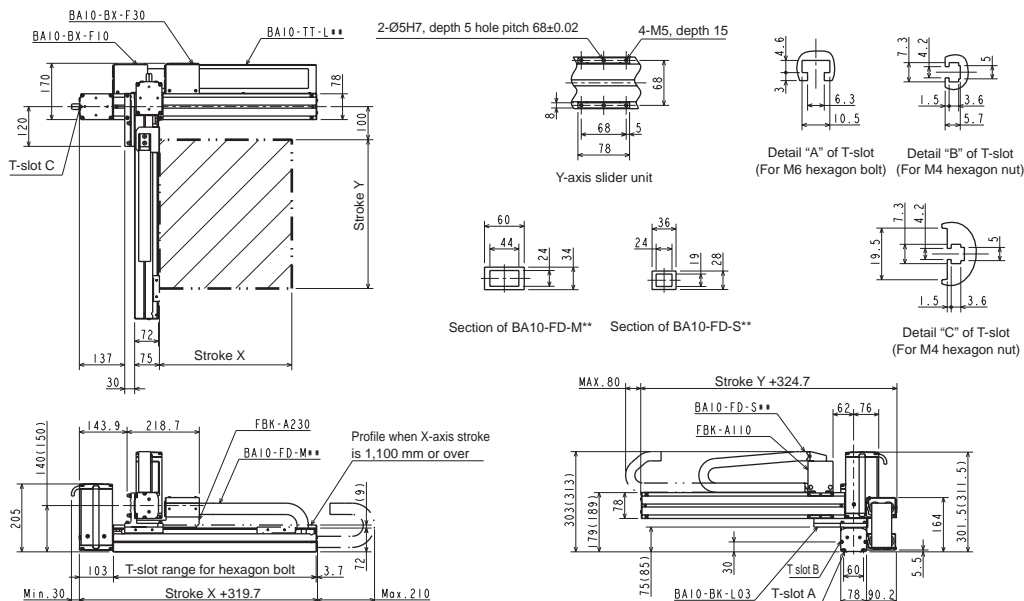

[Set designation]

BA3 - L3 - A2A R C - 40 40 00 - OF 1 3

Combined operation	Axis 1 stroke	Axis 2 stroke	Controller (CA25-M10)	Cable length
R: Right-handed	10 : 100mm	JO : 1800mm	0 : None	3 : 3m 9 : 9m
L: Left-handed	90 : 900mm	NO : 2200mm	1 : NPN output specifications	5 : 5m B : 11m
	A0 : 1000mm	PO : 2300mm	Other : See page 20	7 : 7m D : 13m
	H0 : 1700mm	V0 : 2900mm		
	W0 : 3000mm			
	W20 : 3200mm			

Timing belt type

X-axis: Timing belt driven
Side mounted motor

Y-axis: Timing belt driven
Side mounted motor

[Specifications]

	X-axis	Y-axis
Type of axis	BE30E-BT-M21N-□ 0	BE10E-B□ -M21N-□ 0
Stroke (in increments of 100 mm)	100 ~ 3200mm	100 ~ 800mm
Maximum speed	1000mm/s	1000mm/s
Positioning repeatability	±0.04mm	
Lead	21mm	21mm
Motor output	100W	100W
Resolution	0.01mm	

Acceleration/deceleration time when the maximum speed is set: 0.3 sec. or over

Maximum payload (kg)	Y-axis stroke							
	100mm	200mm	300mm	400mm	500mm	600mm	700mm	800mm
	8.0	7.0	6.0	6.0	5.0	5.0	1.0	1.0

R: Right-handed

The values in parentheses are applicable when the X-axis stroke is 1,850 mm or over.

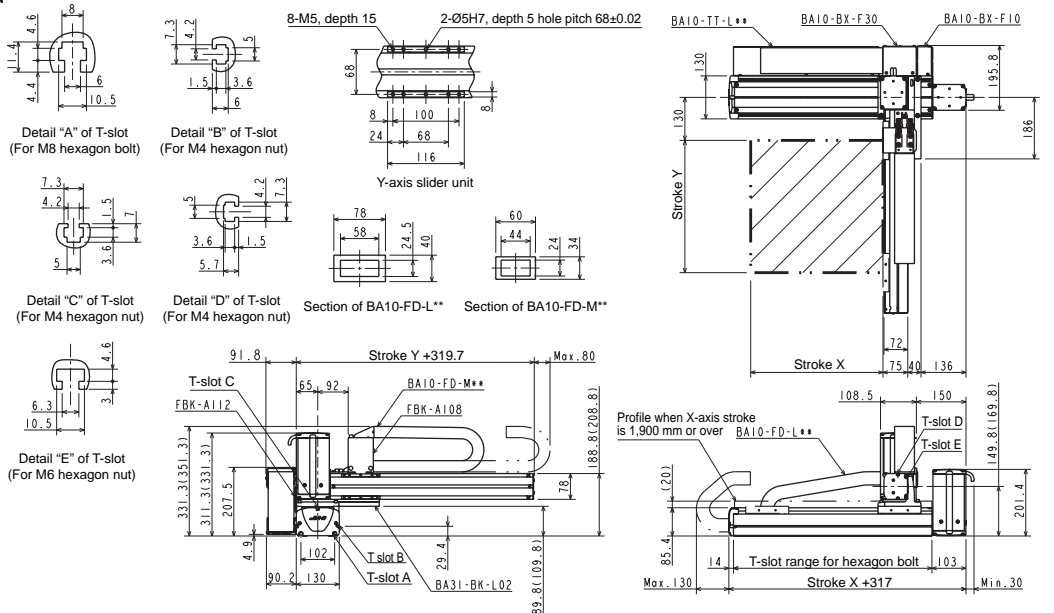

L: Left-handed

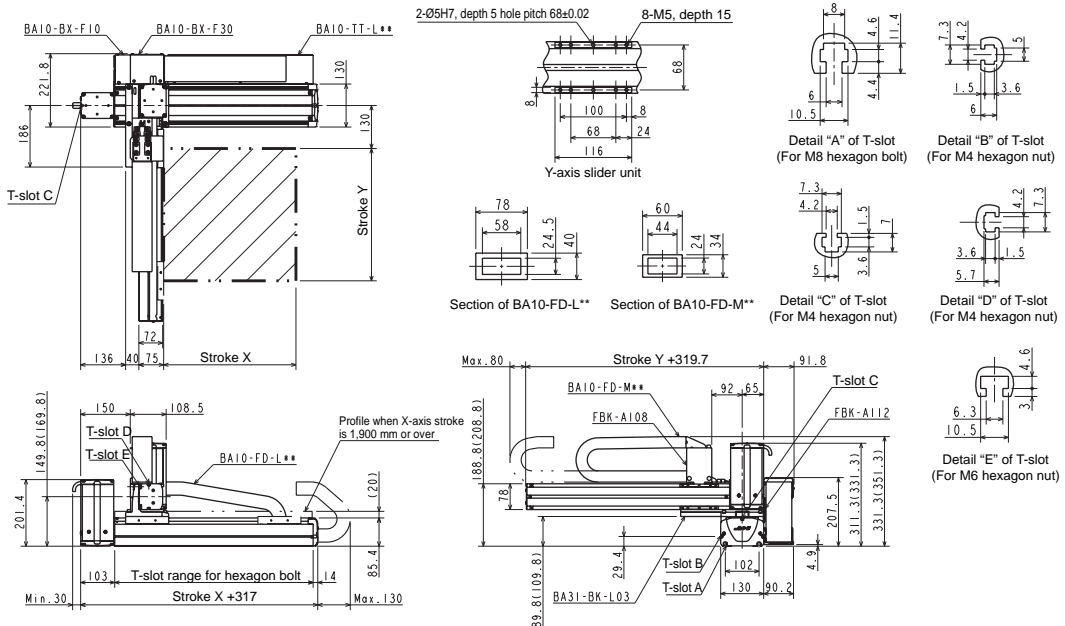

[Set designation]

BA3 - L3 - A2B R C - 40 40 00 - OF 1 3

Combined operation	Axis 1 stroke	Axis 2 stroke	Controller (CA25-M10)	Cable length
R: Right-handed	10 : 100mm JO : 1800mm	10 : 100mm	0 : None	3 : 3m 9 : 9m
L: Left-handed	90 : 900mm AO : 1000mm HO : 1700mm	NO : 2200mm PO : 2300mm VO : 2900mm W0 : 3000mm W20 : 3200mm	1 : NPN output specifications Other : See page 20	5 : 5m B : 11m 7 : 7m D : 13m

Timing belt type

X-axis: Timing belt driven
Side mounted motor

Y-axis: Timing belt driven
Side mounted motor

[Specifications]

	X-axis	Y-axis
Type of axis	BE30F-BT-M21N-□ 0	BE10E-B□ -M21N-□ 0
Stroke (in increments of 100 mm)	100 ~ 3200mm	100 ~ 800mm
Maximum speed	1000mm/s	1000mm/s
Positioning repeatability	± 0.04mm	
Lead	21 mm	21 mm
Motor output	200W	100W
Resolution	0.01 mm	

Acceleration/deceleration time when the maximum speed is set: 0.3 sec. or over

Maximum payload (kg)	Y-axis stroke							
	100mm	200mm	300mm	400mm	500mm	600mm	700mm	800mm
	15.0	15.0	14.0	11.0	8.0	6.0	4.0	2.0

R: Right-handed

The values in parentheses are applicable when the X-axis stroke is 1,850 mm or over.

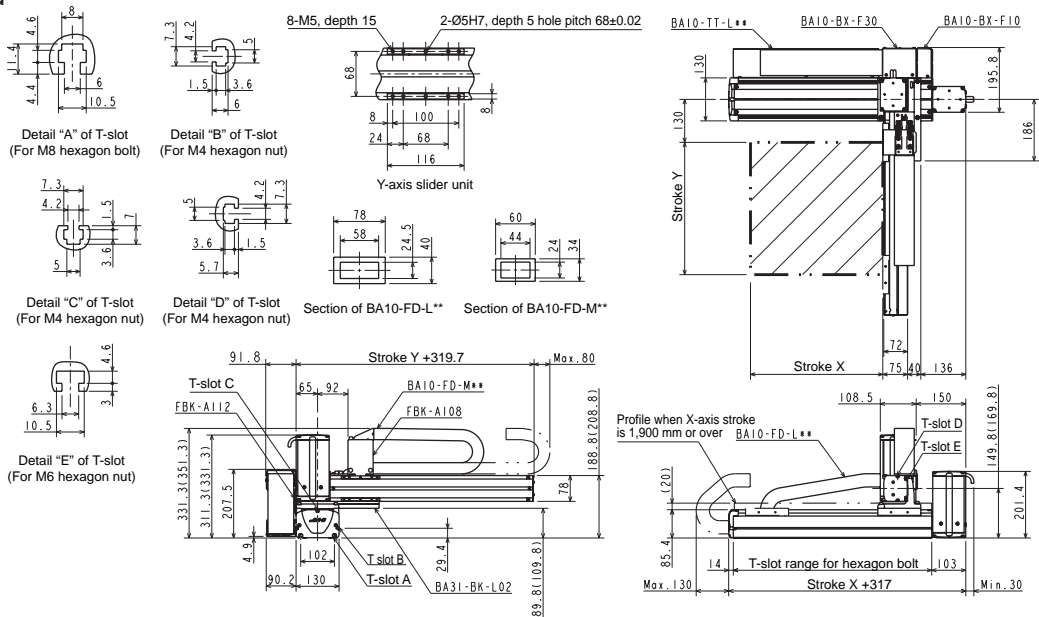

L: Left-handed

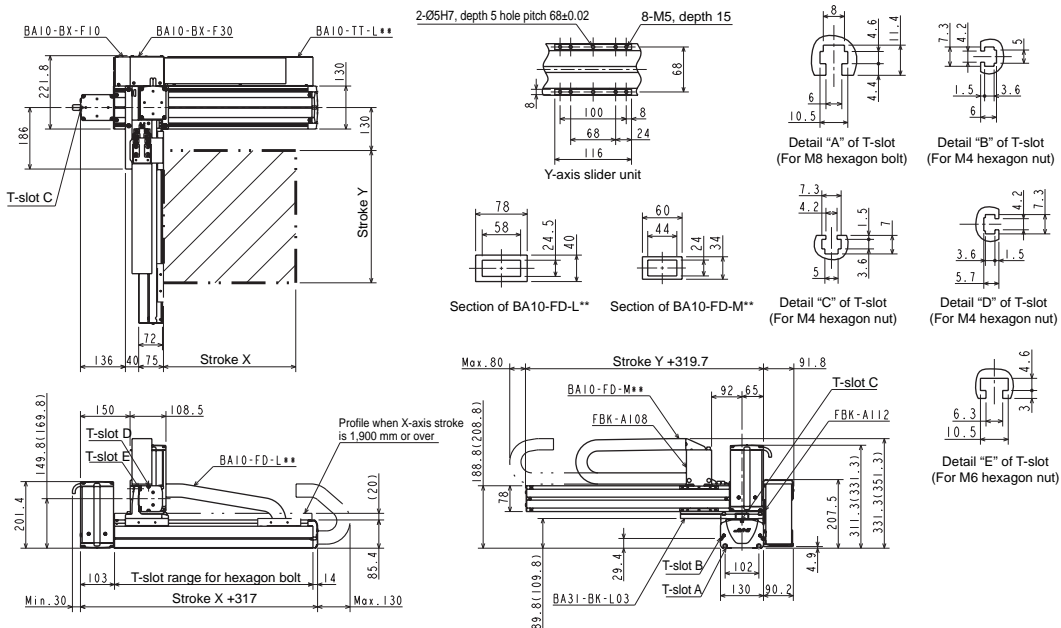

[Set designation]

BA3 - L3 - A2C R C - 40 40 00 - OF 1 3

Combined operation	Axis 1 stroke	Axis 2 stroke	Controller (CA25-M10)	Cable length
R: Right-handed	10 : 100mm	JO : 1800mm	0 : None	3 : 3m 9 : 9m
L: Left-handed	90 : 900mm	NO : 2200mm	1 : NPN output specifications	5 : 5m B : 11m
	A0 : 1000mm	PO : 2300mm	Other : See page 20	7 : 7m D : 13m
	H0 : 1700mm	V0 : 2900mm		
	W0 : 3000mm	W20 : 3200mm		

Timing belt type

X-axis: Timing belt driven
Side mounted motor

Y-axis: Timing belt driven
Side mounted motor

[Specifications]

	X-axis	Y-axis
Type of axis	BE30F-BT-M21N-□ 0	BE10F-B□ -M21N-□ 0
Stroke (in increments of 100 mm)	100 ~ 3200mm	100 ~ 800mm
Maximum speed	1000mm/s	1000mm/s
Positioning repeatability	±0.04mm	
Lead	21mm	21mm
Motor output	200W	200W
Resolution	0.01mm	

Acceleration/deceleration time when the maximum speed is set: 0.3 sec. or over

Maximum payload (kg)	Y-axis stroke							
	100mm	200mm	300mm	400mm	500mm	600mm	700mm	800mm
	20.0	18.0	14.0	11.0	8.0	6.0	4.0	2.0

R: Right-handed

The values in parentheses are applicable when the X-axis stroke is 1,850 mm or over.

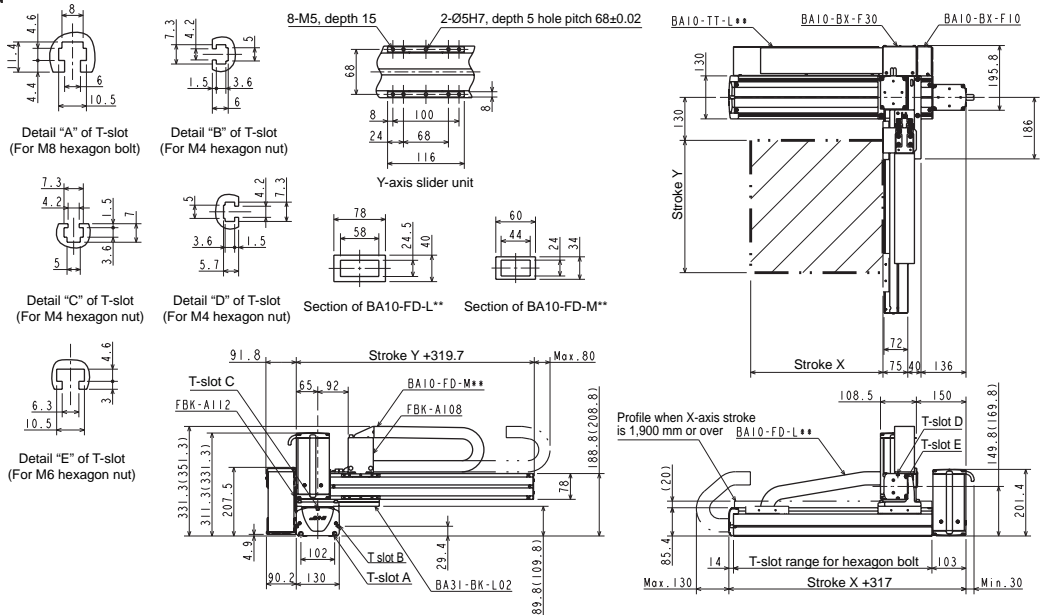

L: Left-handed

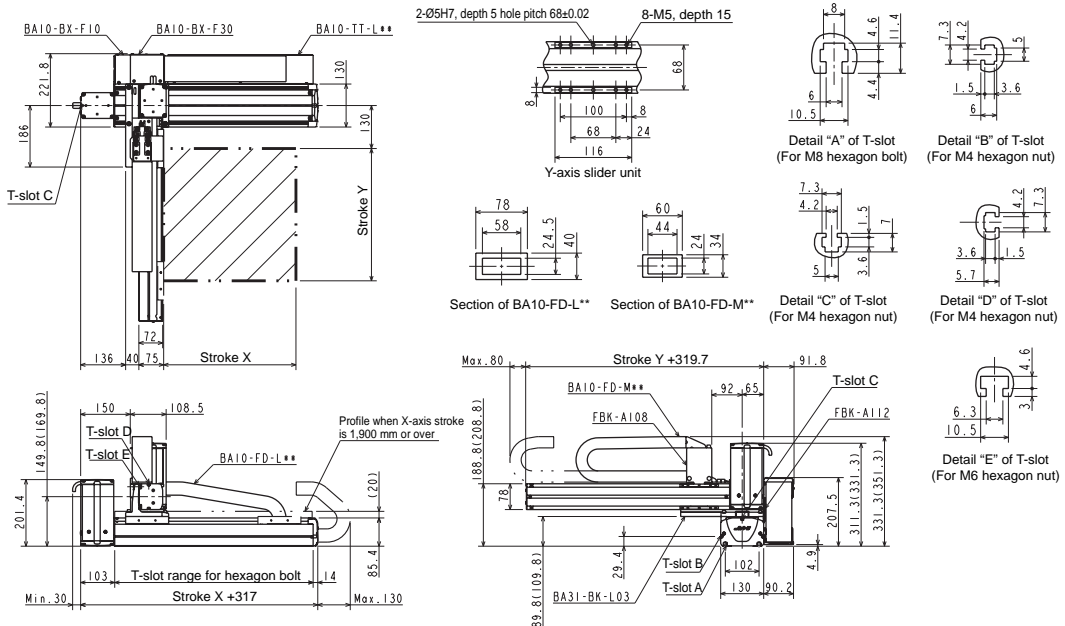

[Set designation]

BA3 - L5 - A2A R C - 40 40 00 - OF 1 3

Combined operation	Axis 1 stroke	Axis 2 stroke	Controller (CA25-M10)	Cable length	
R: Right-handed	10 : 100mm 90 : 900mm A0 : 1000mm H0 : 1700mm	J0 : 1800mm N0 : 2200mm P0 : 2300mm V0 : 2900mm W0 : 3000mm W60 : 3500mm	10 : 100mm 90 : 900mm A0 : 1000mm	0 : None 1 : NPN output specifications Other : See page 20	3 : 3m 9 : 9m 5 : 5m B : 11m 7 : 7m D : 13m

Timing belt type

X-axis: Timing belt driven
Side mounted motor

Y-axis: Timing belt driven
Side mounted motor

[Specifications]

	X-axis	Y-axis
Type of axis	BE50F-BT-M21N-□ 0	BE30E-B□-M21N-□ 0
Stroke (in increments of 100 mm)	200 ~ 3500mm	100 ~ 1000mm
Maximum speed	1000mm/s	1000mm/s
Positioning repeatability	±0.04mm	
Lead	21 mm	21 mm
Motor output	200W	100W
Resolution	0.01 mm	

Acceleration/deceleration time when the maximum speed is set: 0.3 sec. or over

Maximum payload (kg)	Y-axis stroke									
	100mm	200mm	300mm	400mm	500mm	600mm	700mm	800mm	900mm	1000mm
	15.0	15.0	15.0	15.0	15.0	15.0	15.0	13.0	12.0	11.0

R: Right-handed

The values in parentheses are applicable when the X-axis stroke is 1,850 mm or over.

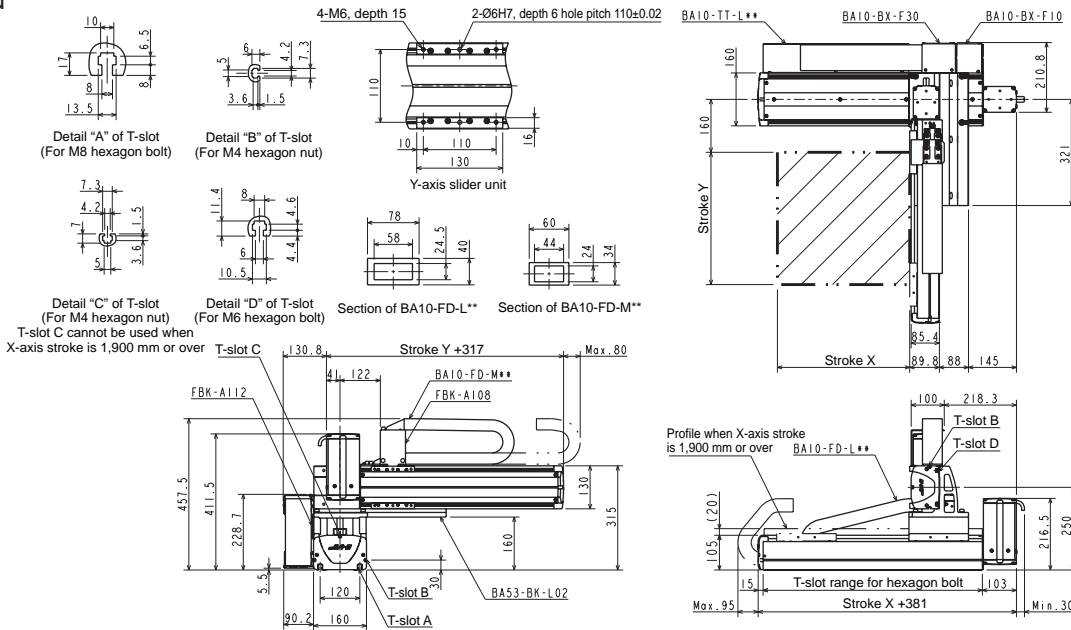

L: Left-handed

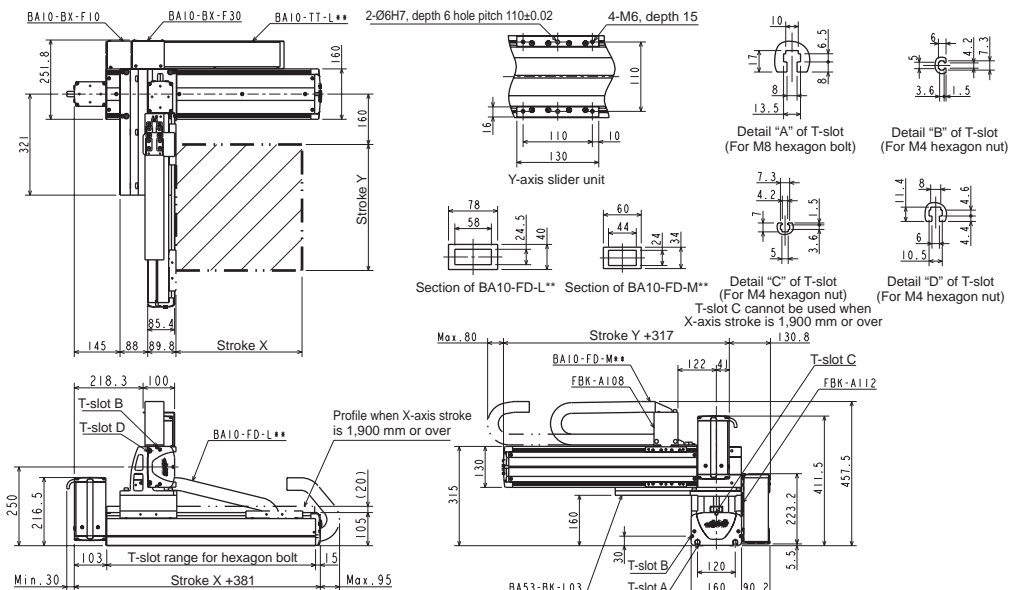

[Set designation]

BA3 - L5 - A2B R C - 40 40 00 - OF 1 3

Combined operation	Axis 1 stroke	Axis 2 stroke	Controller (CA25-M10)	Cable length	
R: Right-handed	10 : 100mm 90 : 900mm A0 : 1000mm H0 : 1700mm	JO : 1800mm NO : 2200mm PO : 2300mm V0 : 2900mm W0 : 3000mm W50 : 3500mm	10 : 100mm 90 : 900mm A0 : 1000mm	0 : None 1 : NPN output specifications Other : See page 20	3 : 3m 9 : 9m 5 : 5m B : 11m 7 : 7m D : 13m

Timing belt type

X-axis: Timing belt driven
Side mounted motor

Y-axis: Timing belt driven
Side mounted motor

[Specifications]

	X-axis	Y-axis
Type of axis	BE50F-BT-M21N-□ 0	BE30F-B □ -M21N-□ 0
Stroke (in increments of 100 mm)	200 ~ 3500mm	100 ~ 1000mm
Maximum speed	1000mm/s	1000mm/s
Positioning repeatability	±0.04mm	
Lead	21mm	21mm
Motor output	200W	200W
Resolution	0.01mm	

Acceleration/deceleration time when the maximum speed is set: 0.3 sec. or over

Maximum payload (kg)	Y-axis stroke									
	100mm	200mm	300mm	400mm	500mm	600mm	700mm	800mm	900mm	1000mm
	20.0	19.0	18.0	17.0	16.0	15.0	14.0	13.0	12.0	10.0

R: Right-handed

The values in parentheses are applicable when the X-axis stroke is 1,850 mm or over.

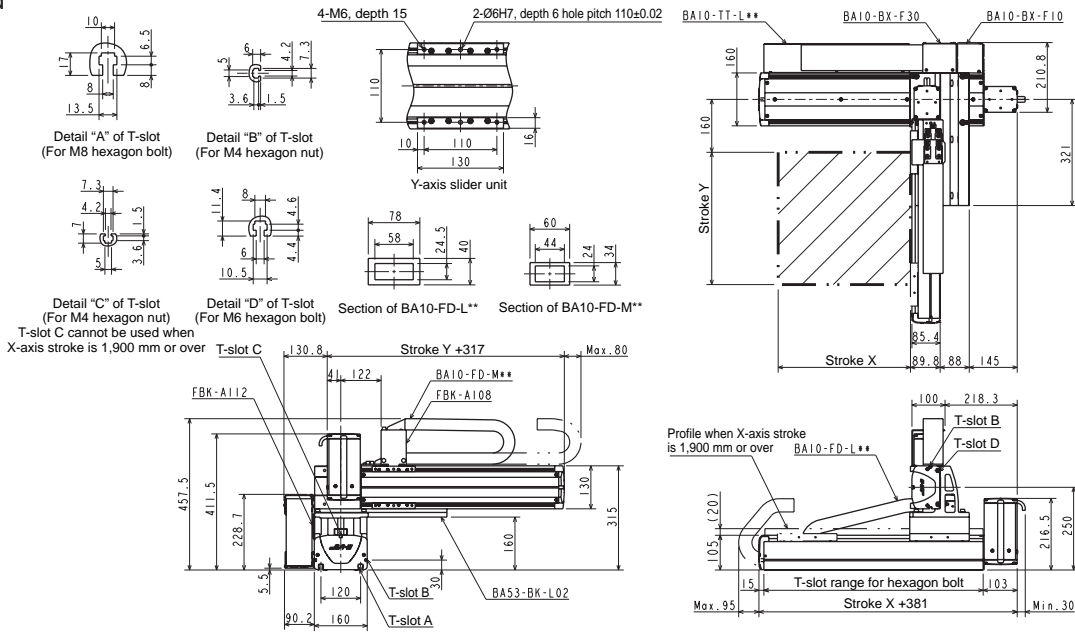

L: Left-handed

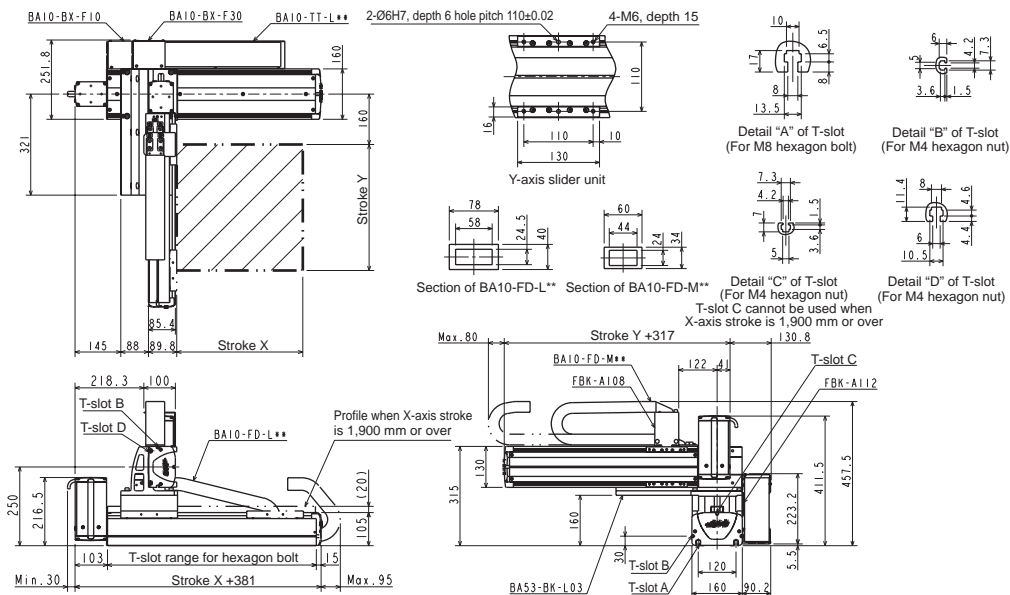

[Set designation]

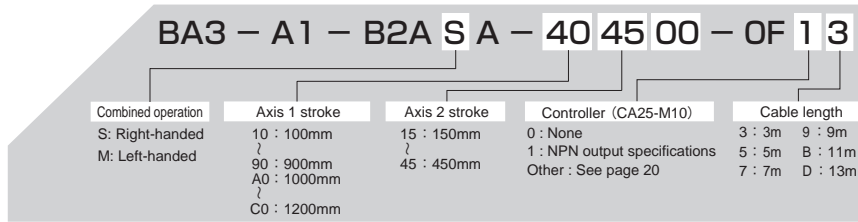

Ball screw type

X-axis: Ball screw driven
Motor straight

Z-axis: Ball screw driven
Motor straight

[Specifications]

	X-axis	Z-axis
Type of axis	BE10E-ST-M20N-□0	BE10E-ST-S10B-□5
Stroke (in increments of 100 mm)	100 ~ 1200mm	150 ~ 450mm
Maximum speed	1200mm/s (Note 1)	600mm/s
Positioning repeatability	±0.01mm	
Lead	20mm	10mm
Motor output	100W	100W, with brake
Resolution	0.01mm	

Note 1: When the stroke is as given below, the maximum speed differs.

	Stroke (mm)	Maximum speed (mm/s)
X-axis	700	1000
	800	800
	900~1000	600
	1100~1200	400

Acceleration/deceleration time when the maximum speed is set: 0.36 sec. or over

Maximum payload (kg) (Note 2)	Z-axis stroke			
	150mm	250mm	350mm	450mm
	8.0	6.0	4.0	2.0

Note 2: Payload when a regenerative discharge unit (ABSU-2000) is used.

S: Right-handed

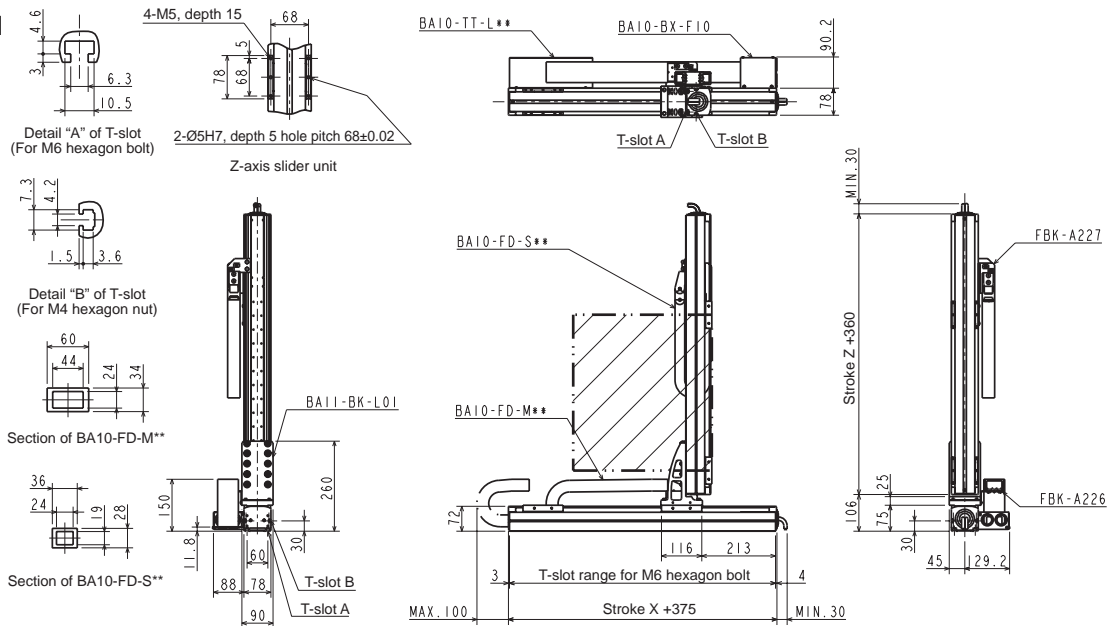

M: Left-handed

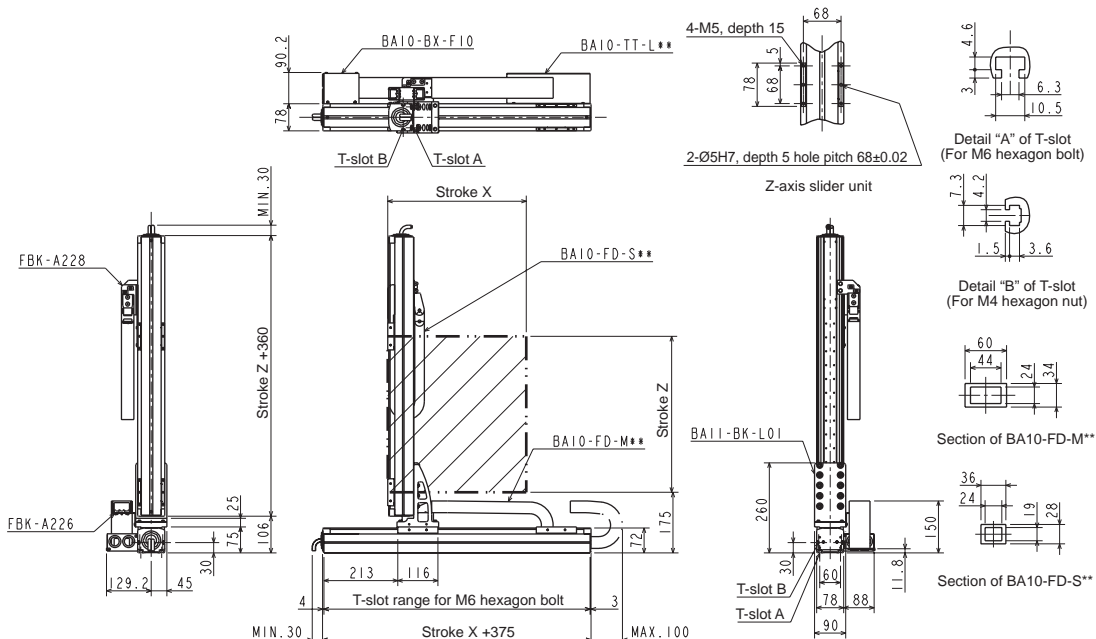

[Set designation]

BA3 - A3 - B2A S A - 45 40 00 - OF 1 3

Combined operation S: Right-handed M: Left-handed	Axis 1 stroke 10 : 100mm 95 : 950mm A5 : 1050mm C5 : 1250mm	Axis 2 stroke 10 : 100mm 70 : 700mm	Controller (CA25-M10) 0 : None 1 : NPN output specifications Other : See page 20	Cable length 3 : 3m 9 : 9m 5 : 5m B : 11m 7 : 7m D : 13m
---	---	---	---	---

Ball screw type

X-axis: Ball screw driven
Motor straight

Z-axis: Ball screw driven
Motor straight

[Specifications]

	X-axis	Z-axis
Type of axis	BE30E-ST-M20N-□5	BE10E-ST-M10B-□0
Stroke (in increments of 100 mm)	150 ~ 1250mm	100 ~ 700mm
Maximum speed	1200mm/s (Note 1)	600mm/s (Note 1)
Positioning repeatability	±0.01mm	
Lead	20mm	10mm
Motor output	100W	100W, with brake
Resolution	0.01mm	

Note 1: When the stroke is as given below, the maximum speed differs.

	Stroke (mm)	Maximum speed (mm/s)
X-axis	750	1000
	850	800
	950~1050	600
Z-axis	1150~1250	400
Z-axis	700	500

Acceleration/deceleration time when the maximum speed is set: 0.6 sec. or over

Maximum payload (kg) (Note 2)	Z-axis stroke						
	100mm	200mm	300mm	400mm	500mm	600mm	700mm
	9.0	8.0	8.0	8.0	6.0	4.0	2.0

Note 2: Payload when a regenerative discharge unit (ABSU-2000) is used.

S: Right-handed

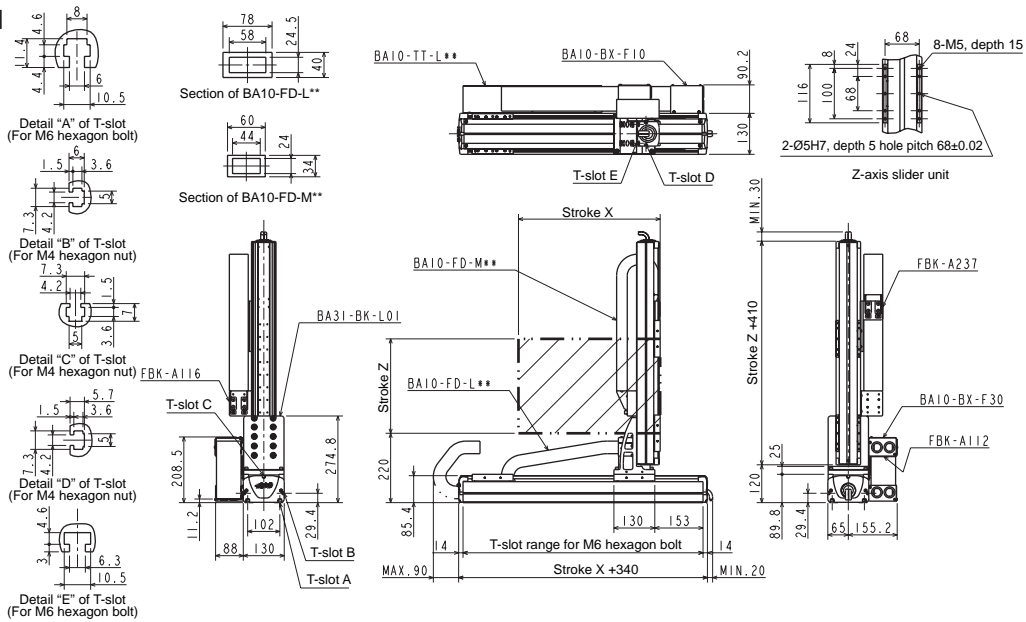

M: Left-handed

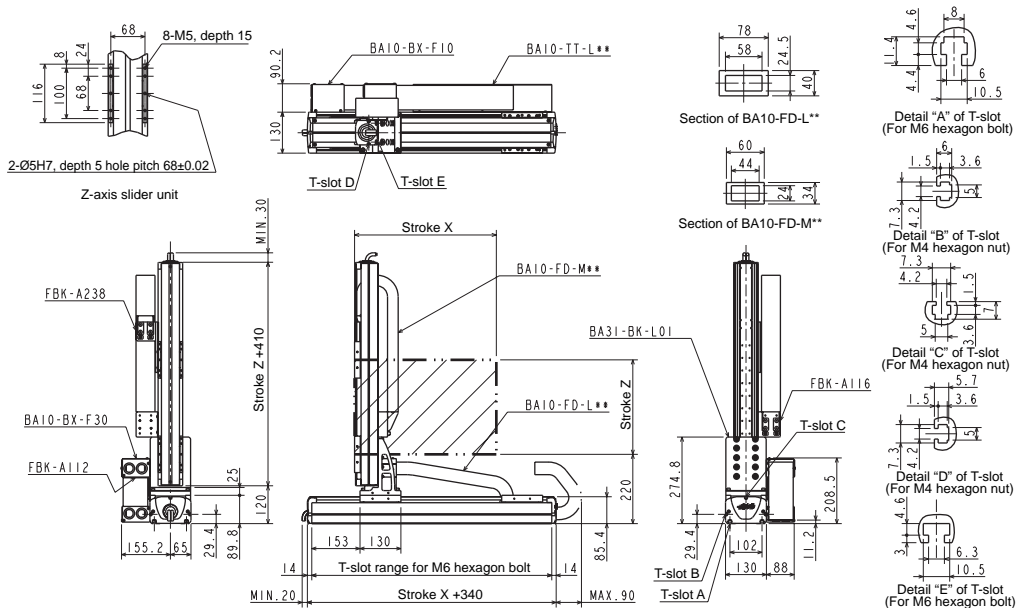

[Set designation]

BA3 - A3 - B2B S A - 40 40 00 - OF 1 3

Combined operation S: Right-handed M: Left-handed	Axis 1 stroke 10 : 100mm 90 : 900mm A0 : 1000mm C0 : 1200mm	Axis 2 stroke 10 : 100mm 90 : 900mm	Controller (CA25-M10) 0 : None 1 : NPN output specifications Other : See page 20	Cable length 3 : 3m 9 : 9m 5 : 5m B : 11m 7 : 7m D : 13m
---	---	---	---	---

Ball screw type

X-axis: Ball screw driven
Motor straight

Z-axis: Ball screw driven
Motor straight

Note 1: When the stroke is as given below, the maximum speed differs.

	Stroke (mm)	Maximum speed (mm/s)
X-axis	700	1000
	800	800
	900~1000	600
	1100~1200	400
Z-axis	700	500
	800	400
	900	300

[Specifications]

	X-axis	Z-axis
Type of axis	BE30F-ST-M20N-□ 0	BE10E-ST-M10B-□ 0
Stroke (in increments of 100 mm)	100 ~ 1200mm	100 ~ 900mm
Maximum speed	1200mm/s (Note 1)	600mm/s (Note 1)
Positioning repeatability	± 0.01mm	
Lead	20mm	10mm
Motor output	200W	100W, with brake
Resolution	0.01mm	

Acceleration/deceleration time when the maximum speed is set: 0.36 sec. or over

Maximum payload (kg) (Note 2)	Z-axis stroke								
	100mm	200mm	300mm	400mm	500mm	600mm	700mm	800mm	900mm
	12.0	12.0	12.0	12.0	12.0	10.0	4.0	2.0	2.0

Note 2: Payload when a regenerative discharge unit (ABSU-2000) is used.

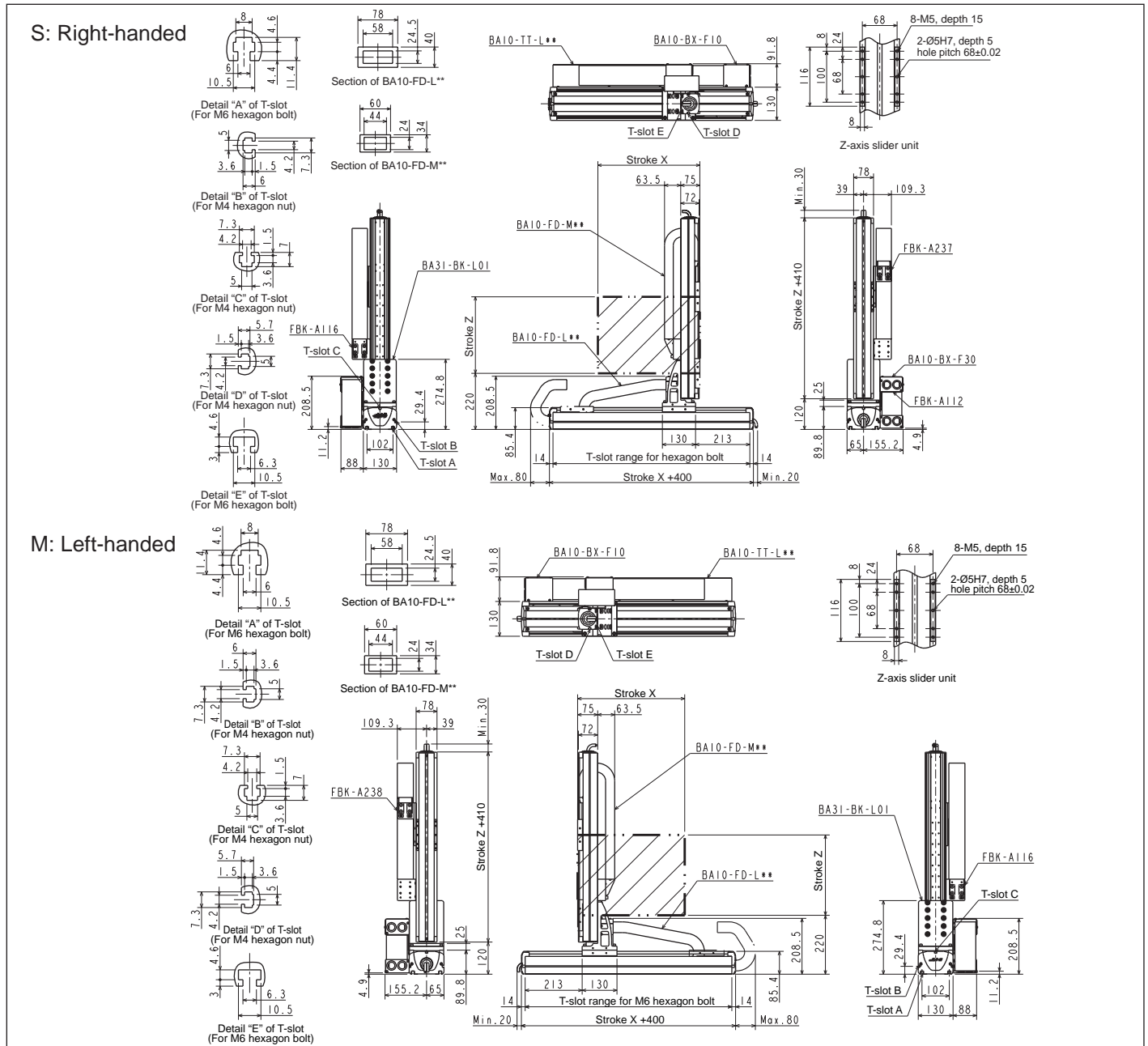

X-Z Flexible-duct Spec.

[Set designation]

BA3 – A5 – B2A S A – 40 45 00 – OF 1 3

Combined operation S: Right-handed M: Left-handed	Axis 1 stroke 20 : 200mm 90 : 900mm A0 : 1000mm G0 : 1600mm	Axis 2 stroke 15 : 150mm 95 : 950mm A5 : 1050mm	Controller (CA25-M10) 0 : None 1 : NPN output specifications Other : See page 20	Cable length 3 : 3m 9 : 9m 5 : 5m B : 11m 7 : 7m D : 13m
---	---	--	---	---

Ball screw type

X-axis: Ball screw driven
Motor straight

Z-axis: Ball screw driven
Motor straight

Note 1: When the stroke is as given below, the maximum speed differs.

[Specifications]

	X-axis	Z-axis
Type of axis	BE50F-ST-M20N-□ 0	BE30E-ST-M10B-□ 0
Stroke (in increments of 100 mm)	200 ~ 1600mm	150 ~ 1050mm
Maximum speed	1200mm/s (Note 1)	600mm/s (Note 1)
Positioning repeatability	± 0.01mm	
Lead	20mm	10mm
Motor output	200W	100W, with brake
Resolution	0.01mm	

Acceleration/deceleration time when the maximum speed is set: 0.36 sec. or over

	Stroke (mm)	Maximum speed (mm/s)
X-axis	700~800	1100
	900~1000	1000
	1100~1200	700
	1300	500
	1400	400
	1500	300
Z-axis	1600	200
	750	500
	850	400
	950~1050	300

Maximum payload (kg) (Note 2)	Z-axis stroke									
	150mm	250mm	350mm	450mm	550mm	650mm	750mm	850mm	950mm	1050mm
	12.0	12.0	12.0	12.0	12.0	12.0	12.0	12.0	12.0	8.0

Note 2: Payload when a regenerative discharge unit (ABSU-2000) is used.

S: Right-handed

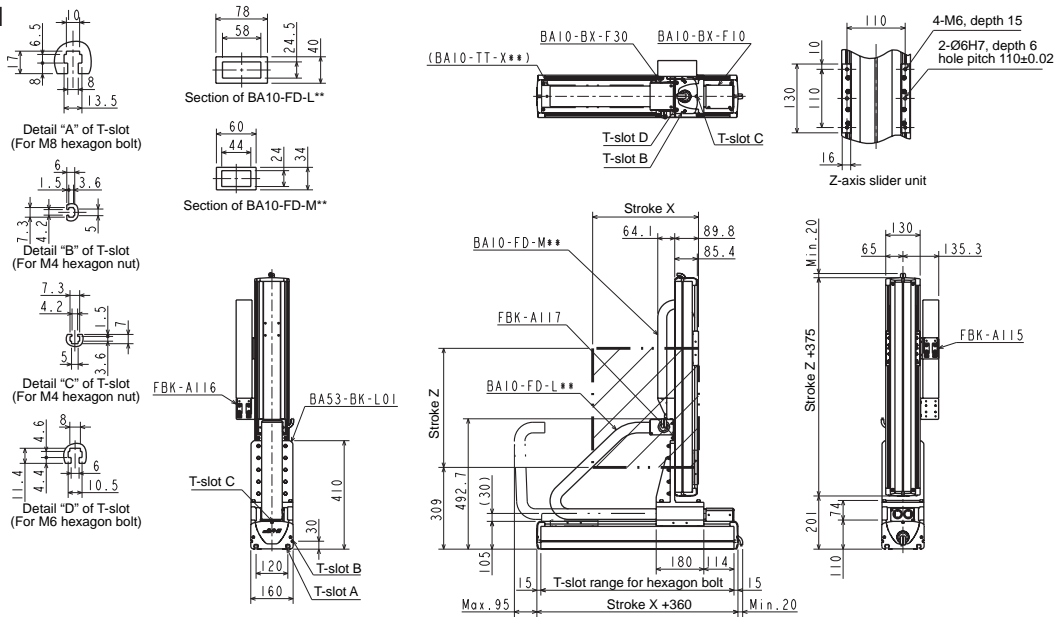

M: Left-handed

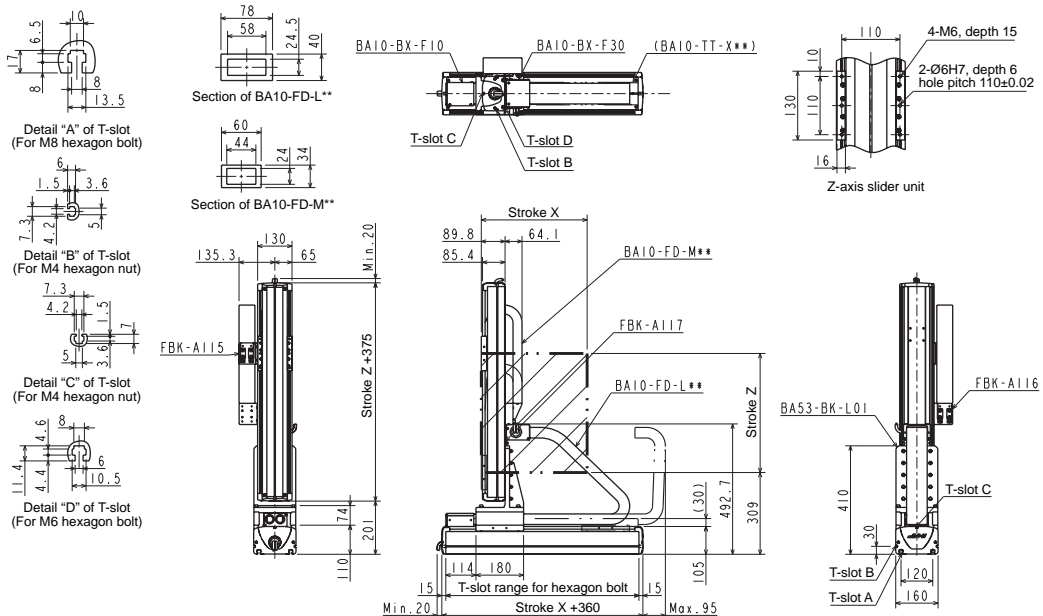

[Set designation]

BA3 – A5 – B2B S A – 40 40 00 – OF 1 3

Combined operation S: Right-handed M: Left-handed	Axis 1 stroke 20 : 200mm 90 : 900mm A0 : 1000mm G0 : 1600mm	Axis 2 stroke 10 : 100mm 90 : 900mm A0 : 1000mm	Controller (CA25-M10) 0 : None 1 : NPN output specifications Other : See page 20	Cable length 3 : 3m 9 : 9m 5 : 5m B : 11m 7 : 7m D : 13m
---	---	--	---	---

Ball screw type

X-axis: Ball screw driven
Motor straight

Z-axis: Ball screw driven
Motor straight

Note 1: When the stroke is as given below, the maximum speed differs.

[Specifications]

	X-axis	Z-axis
Type of axis	BE50F-ST-M20N-□ 0	BE30F-ST-M10B-□ 0
Stroke (in increments of 100 mm)	200 ~ 1600mm	100 ~ 1000mm
Maximum speed	1200mm/s (Note 1)	600mm/s (Note 1)
Positioning repeatability	± 0.01mm	
Lead	20mm	10mm
Motor output	200W	200W, with brake
Resolution	0.01mm	

Acceleration/deceleration time when the maximum speed is set: 0.36 sec. or over

	Stroke (mm)	Maximum speed (mm/s)
X-axis	700~800	1100
	900~1000	1000
	1100~1200	700
	1300	500
	1400	400
	1500	300
Z-axis	1600	200
	700	500
	800~1000	400
	900~1000	300

Maximum payload (kg) (Note 2)	Z-axis stroke									
	100mm	200mm	300mm	400mm	500mm	600mm	700mm	800mm	900mm	1000mm
	20.0	20.0	20.0	20.0	20.0	20.0	16.0	13.0	9.0	7.0

Note 2: Payload when a regenerative discharge unit (ABSU-2000) is used.

S: Right-handed

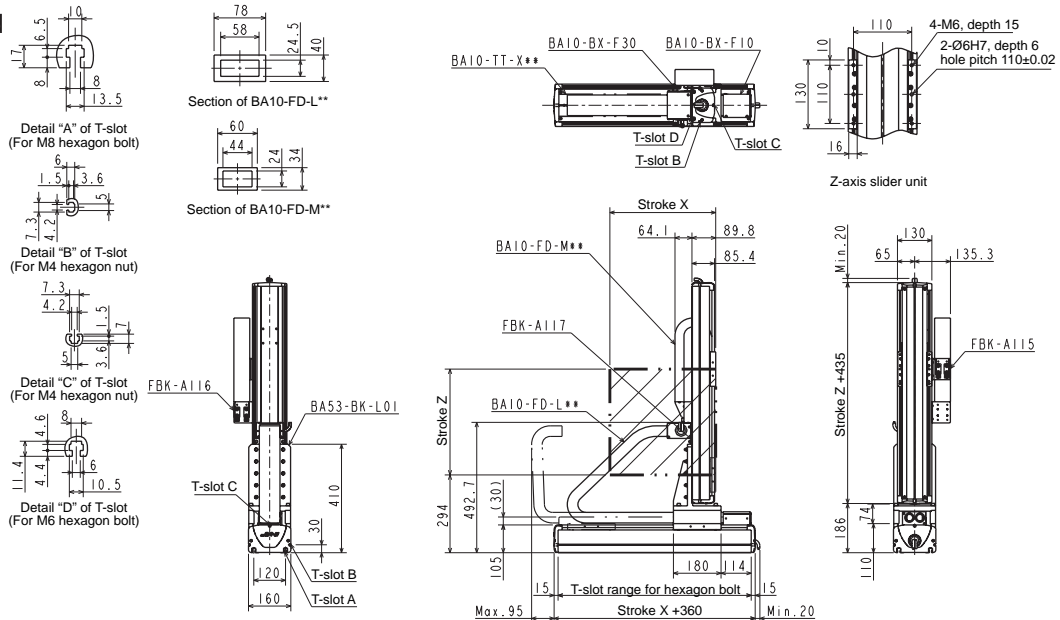

M: Left-handed

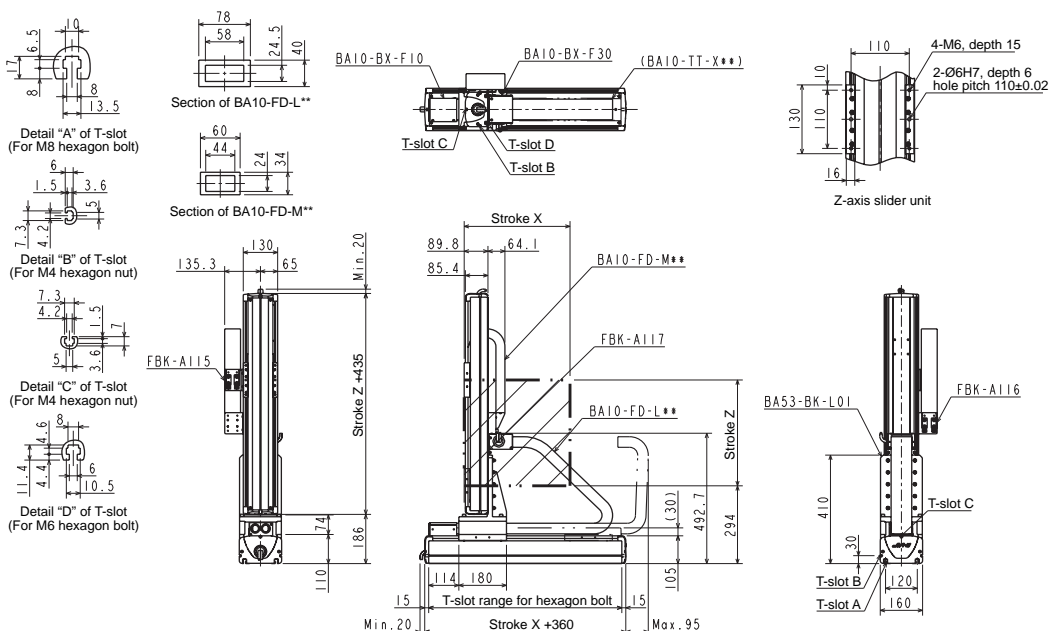

[Set designation]

BA3 – A5 – B2C S A – 40 40 00 – OF 1 3

Combined operation S: Right-handed M: Left-handed	Axis 1 stroke 20 : 200mm 90 : 900mm A0 : 1000mm G0 : 1600mm	Axis 2 stroke 20 : 200mm 90 : 900mm A0 : 1000mm	Controller (CA25-M10) 0 : None 1 : NPN output specifications Other : See page 20	Cable length 3 : 3m 9 : 9m 5 : 5m B : 11m 7 : 7m D : 13m
---	---	--	---	---

Ball screw type

X-axis: Ball screw driven
Motor straight

Z-axis: Ball screw driven
Motor straight

Note 1: When the stroke is as given below, the maximum speed differs.

[Specifications]

	X-axis	Z-axis
Type of axis	BE50F-ST-M20N-□ 0	BE50F-ST-M10B-□ 0
Stroke (in increments of 100 mm)	200 ~ 1600mm	200 ~ 1000mm
Maximum speed	1200mm/s (Note 1)	600mm/s (Note 1)
Positioning repeatability	± 0.01mm	
Lead	20mm	10mm
Motor output	200W	200W, with brake
Resolution	0.01mm	

Acceleration/deceleration time when the maximum speed is set: 0.6 sec. or over

	Stroke (mm)	Maximum speed (mm/s)
X-axis	700~800	1100
	900~1000	1000
	1100~1200	700
	1300	500
	1400	400
	1500	300
Z-axis	1600	200
	750	500
	850	400
	950~1050	300

Maximum payload (kg) (Note 2)	Z-axis stroke								
	200mm	300mm	400mm	500mm	600mm	700mm	800mm	900mm	1000mm
	20.0	20.0	20.0	20.0 (19.0)	20.0 (17.0)	20.0 (15.0)	19.0 (13.0)	12.0 (11.0)	10.0

Note 2: Payload when a regenerative discharge unit (ABSU-2000) is used.

When the X-axis speed exceeds 1,000 mm/s, the values in parentheses are used for the maximum payload.

S: Right-handed

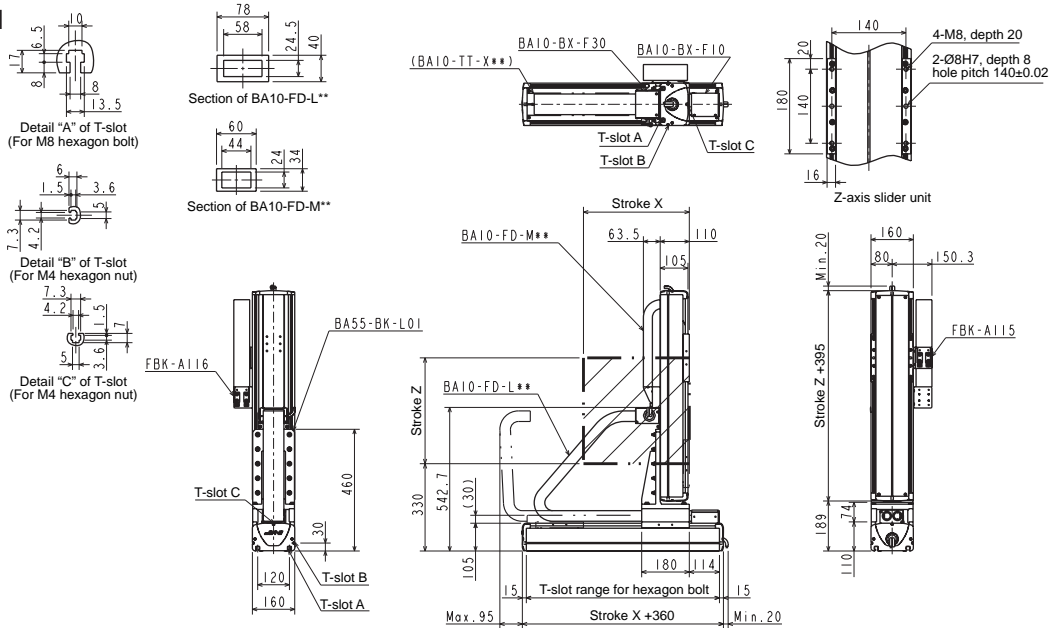

M: Left-handed

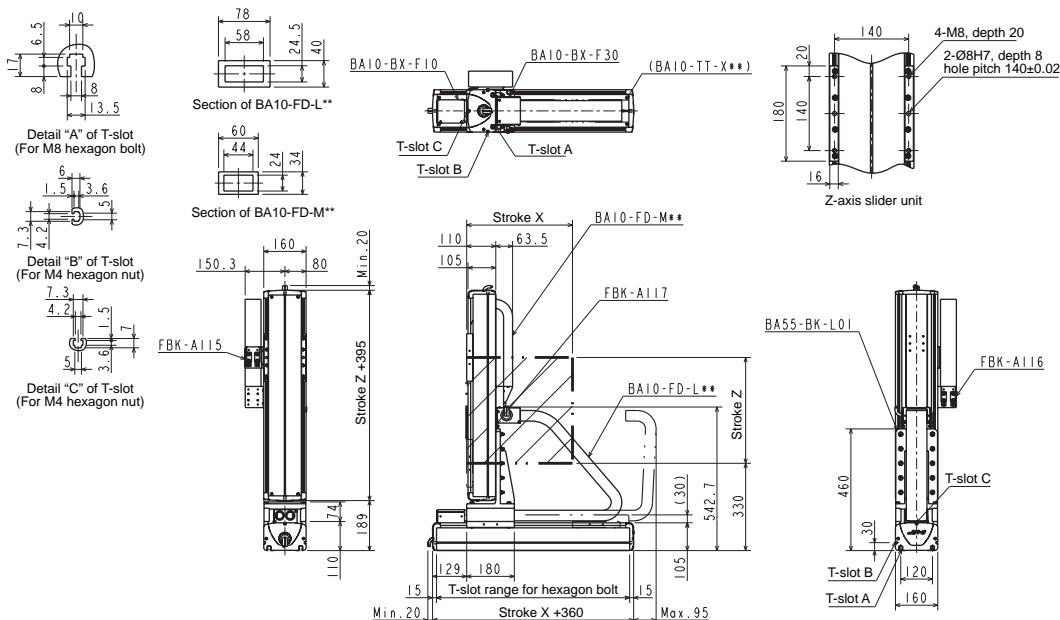

[Set designation]

BA3 - L1 - B2A S S - 40 45 00 - OF 1 3

Combined operation S: Right-handed M: Left-handed	Axis 1 stroke 10 : 100mm 90 : 900mm A0 : 1000mm H0 : 1700mm	Axis 2 stroke JO : 1800mm N0 : 2200mm PO : 2300mm R0 : 2500mm	Axis 2 stroke 15 : 150mm 45 : 450mm	Controller (CA25-M10) 0 : None 1 : NPN output specifications Other : See page 20	Cable length 3 : 3m 5 : 5m 7 : 7m 9 : 9m B : 11m D : 13m
---	---	---	---	---	--

Timing belt type

X-axis: Timing belt driven
Side mounted motor

Z-axis: Ball screw driven
Motor straight

[Specifications]

	X-axis	Z-axis
Type of axis	BE10E-B □ -M21N- □ 0	BE10E-ST-S10B- □ 5
Stroke (in increments of 100 mm)	100 ~ 2500mm	150 ~ 450mm
Maximum speed	1000mm/ s	600mm/ s
Positioning repeatability	± 0.04mm	± 0.01mm
Lead	21 mm (lead converted into ball screw)	10mm
Motor output	100W	100W, with brake
Resolution	0.01mm	

Acceleration/deceleration time when the maximum speed is set: 0.5 sec. or over

Maximum payload (kg)	Z-axis stroke			
	150mm	250mm	350mm	450mm
	7.0	6.0	4.0	2.0

S: Right-handed

The values in parentheses are applicable when the X-axis stroke is 1,050 mm or over.

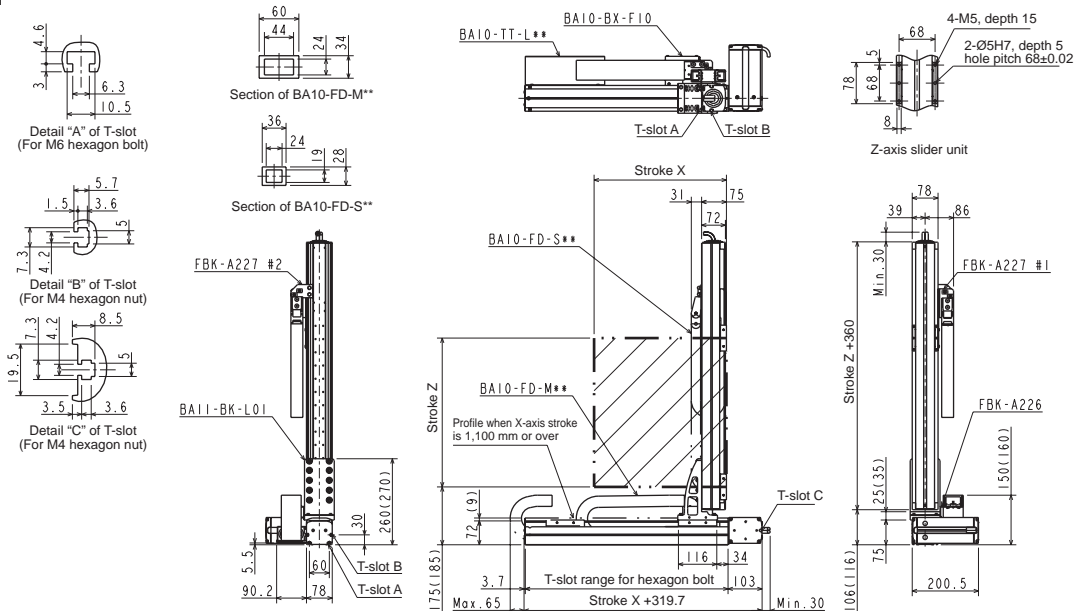

M: Left-handed

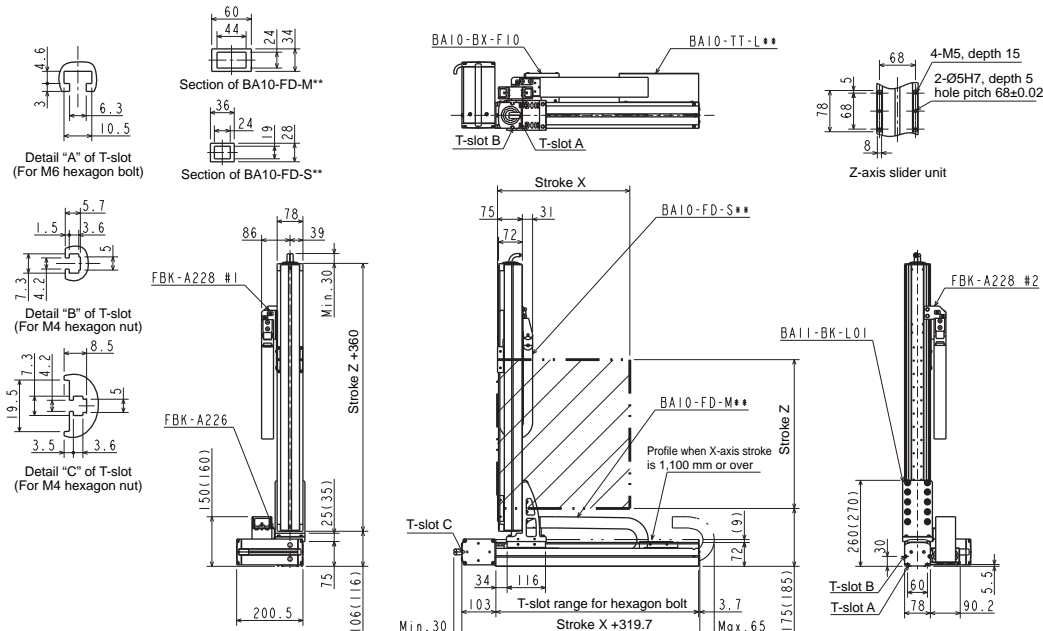

[Set designation]

BA3 - L1 - B2B S S - 40 45 00 - OF 1 3

Combined operation S: Right-handed M: Left-handed	Axis 1 stroke 10 : 100mm 90 : 900mm A0 : 1000mm H0 : 1700mm	Axis 2 stroke 15 : 150mm 45 : 450mm	Controller (CA25-M10) 0 : None 1 : NPN output specifications Other : See page 20	Cable length 3 : 3m 5 : 5m 7 : 7m	9 : 9m B : 11m D : 13m
---	---	---	---	--	------------------------------

Timing belt type

X-axis: Timing belt driven
Side mounted motor

Z-axis: Ball screw driven
Motor straight

[Specifications]

	X-axis	Z-axis
Type of axis	BE10F-B □ -M21N- □ 0	BE10E-ST-S10B- □ 5
Stroke (in increments of 100 mm)	100 ~ 2500mm	150 ~ 450mm
Maximum speed	1000mm/ s	600mm/ s
Positioning repeatability	± 0.04mm	± 0.01mm
Lead of ball screw	21 mm (lead converted into ball screw)	10mm
Motor output	200W	100W, with brake
Resolution	0.01mm	

Acceleration/deceleration time when the maximum speed is set: 0.36 sec. or over

Maximum payload (kg)	Z-axis stroke			
	150mm	250mm	350mm	450mm
	8.0	6.0	4.0	2.0

S: Right-handed

The values in parentheses are applicable when the X-axis stroke is 1,050 mm or over.

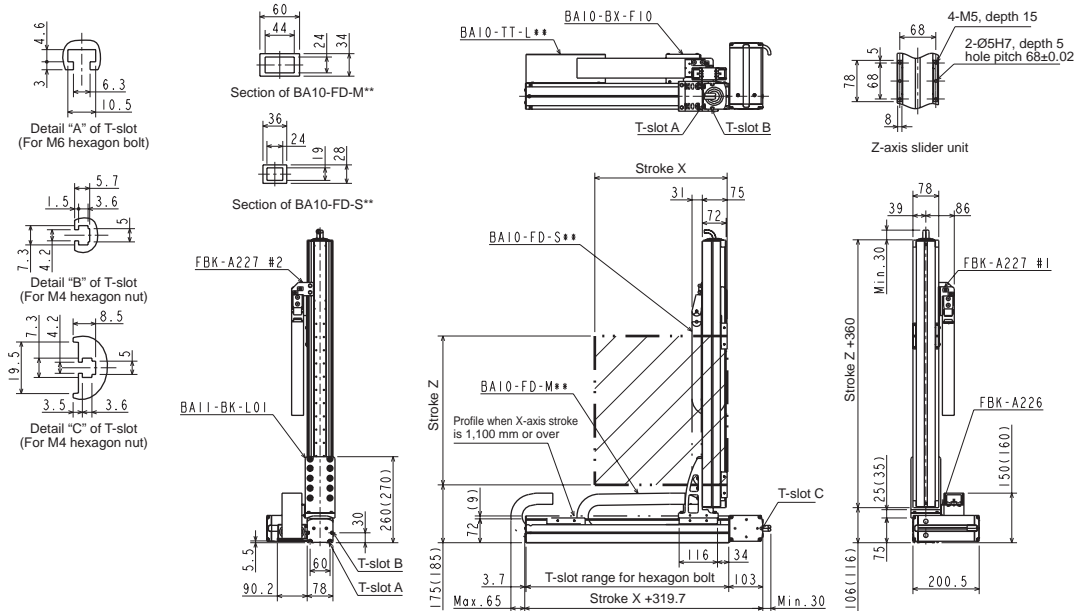

M: Left-handed

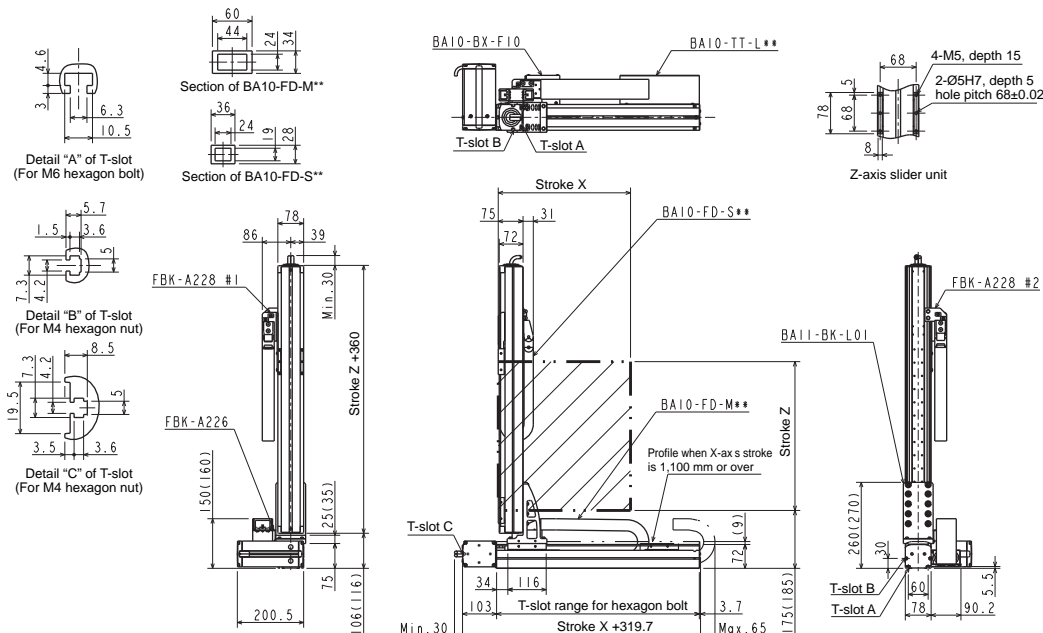

[Set designation]

BA3 - L3 - B2A S S - 40 40 00 - OF 1 3

Combined operation	Axis 1 stroke	Axis 2 stroke	Controller (CA25-M10)	Cable length
S: Right-handed	10 : 100mm JO : 1800mm	10 : 100mm	0 : None	3 : 3m 9 : 9m
M: Left-handed	90 : 900mm AO : 1000mm HO : 1700mm	NO : 2200mm PO : 2300mm VO : 2900mm W0 : 3000mm W20 : 3200mm	1 : NPN output specifications Other : See page 20	5 : 5m B : 11m 7 : 7m D : 13m

Timing belt type

X-axis: Timing belt driven
Side mounted motor

Z-axis: Ball screw driven
Motor straight

[Specifications]

	X-axis	Z-axis
Type of axis	BE30E-B □ -M21N- □ 0	BE10E-ST-M10B- □ 0
Stroke (in increments of 100 mm)	100 ~ 3200mm	100 ~ 700mm
Maximum speed	1000mm/s	600mm/s (Note 1)
Positioning repeatability	± 0.04mm	± 0.01mm
Lead	21mm(lead converted into ball screw)	10mm
Motor output	100W	100W, with brake
Resolution	0.01mm	

Note 1: When the stroke is as given below, the maximum speed differs.

	Stroke (mm)	Maximum speed (mm/s)
Z-axis	700	500

Acceleration/deceleration time when the maximum speed is set: 0.5 sec. or over

Maximum payload (kg)	Z-axis stroke						
	100mm	200mm	300mm	400mm	500mm	600mm	700mm
	5.0	4.0	4.0	3.0	2.0	2.0	1.0

S: Right-handed

The values in parentheses are applicable when the X-axis stroke is 1,850 mm or over.

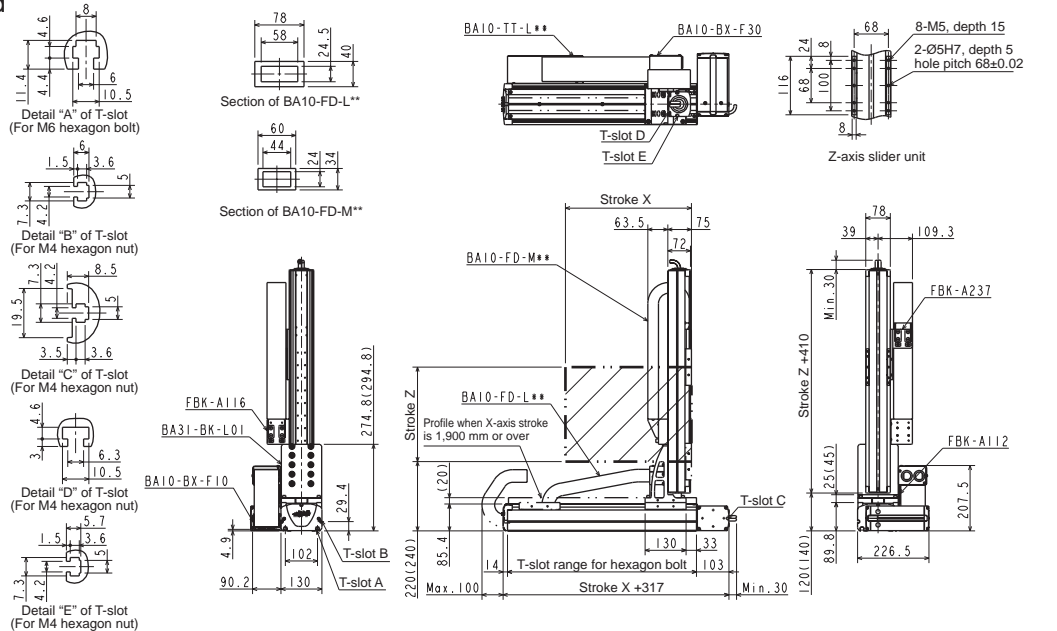

M: Left-handed

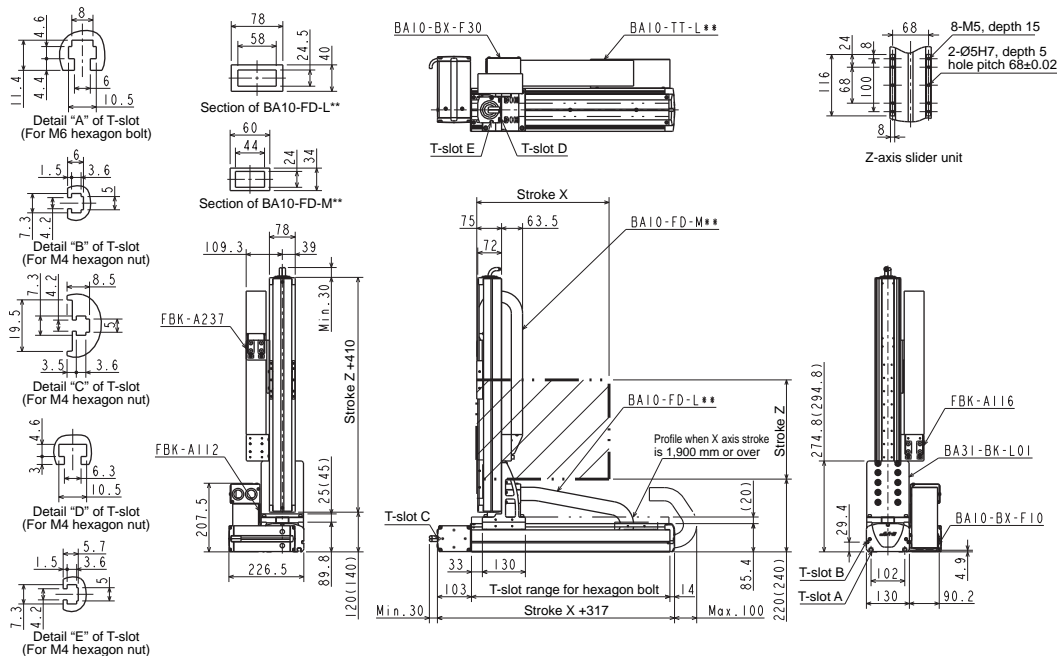

[Set designation]

BA3 - L3 - B2B S S - 40 40 00 - OF 1 3

Combined operation	Axis 1 stroke	Axis 2 stroke	Controller (CA25-M10)	Cable length
S: Right-handed	10 : 100mm JO : 1800mm	10 : 100mm	0 : None	3 : 3m 9 : 9m
M: Left-handed	90 : 900mm NO : 2200mm AO : 1000mm PO : 2300mm HO : 1700mm VO : 2900mm W0 : 3000mm W20 : 3200mm	90 : 900mm	1 : NPN output specifications Other : See page 20	5 : 5m B : 11m 7 : 7m D : 13m

Timing belt type

X-axis: Timing belt driven
Side mounted motor

Z-axis: Ball screw driven
Motor straight

[Specifications]

	X-axis	Z-axis
Type of axis	BE30F-B □ -M21N- □ 0	BE10E-ST-M10B- □ 0
Stroke (in increments of 100 mm)	100 ~ 3200mm	100 ~ 900mm
Maximum speed	1000mm/s	600mm/s (Note 1)
Positioning repeatability	±0.04mm	±0.01mm
Lead	21mm (lead converted into ball screw)	10mm
Motor output	200W	100W, with brake
Resolution	0.01mm	

Note 1: When the stroke is as given below, the maximum speed differs.

Z-axis	Stroke (mm)	Maximum speed (mm/s)
	700	500
	800	400
	900	300

Acceleration/deceleration time when the maximum speed is set: 0.36 sec. or over

Maximum payload (kg) (Note 2)	Z-axis stroke								
	100mm	200mm	300mm	400mm	500mm	600mm	700mm	800mm	900mm
	12.0	12.0	12.0	12.0	12.0	10.0	4.0	2.0	2.0

Note 2: Payload when a regenerative discharge unit (ABSU-2000) is used.

S: Right-handed

The values in parentheses are applicable when the X-axis stroke is 1,850 mm or over.

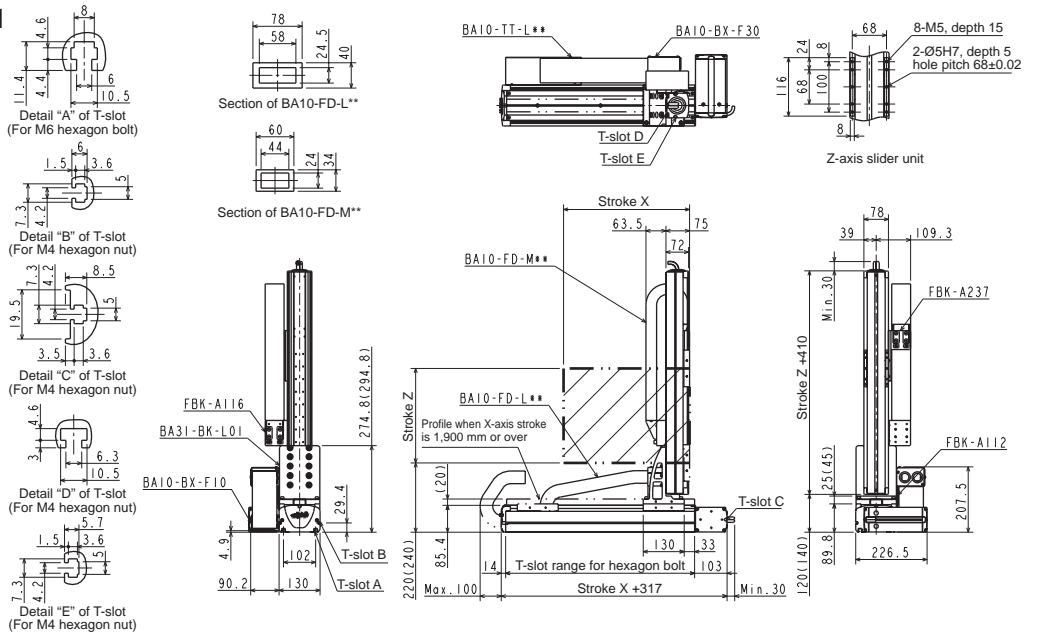

M: Left-handed

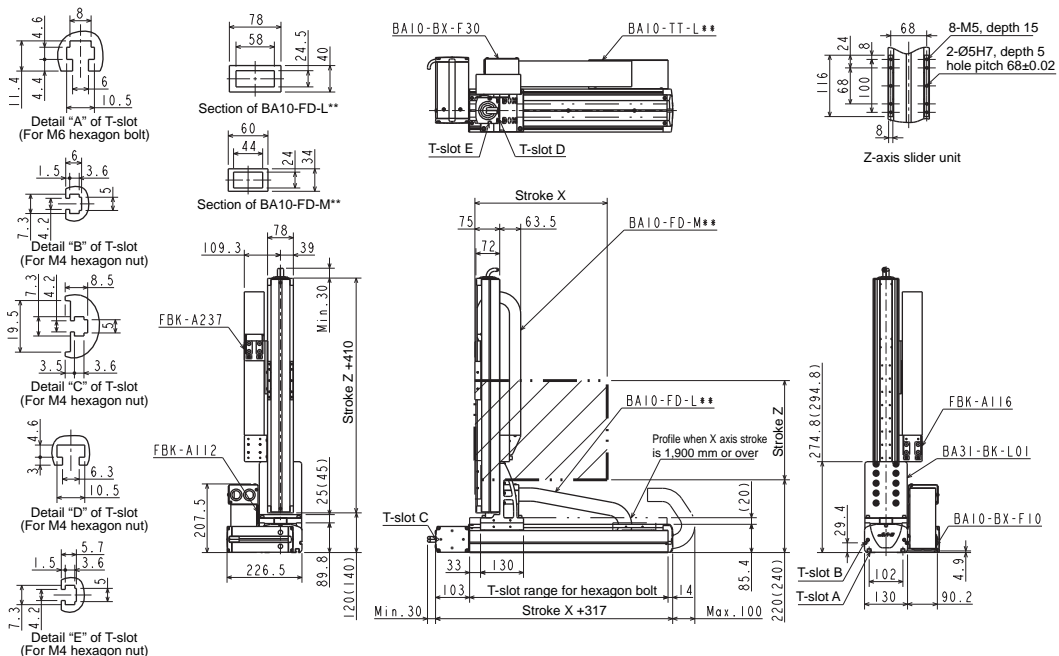

[Set designation]

BA3 - L5 - B2A S S - 40 45 00 - OF 1 3

Combined operation	Axis 1 stroke	Axis 2 stroke	Controller (CA25-M10)	Cable length	
S: Right-handed M: Left-handed	20 : 200mm 90 : 900mm A0 : 1000mm H0 : 1700mm	JO : 1800mm NO : 2200mm PO : 2300mm VO : 2900mm W0 : 3000mm W50 : 3500mm	15 : 150mm 95 : 950mm A5 : 1050mm	0 : None 1 : NPN output specifications Other : See page 20	3 : 3m 5 : 5m 7 : 7m 9 : 9m B : 11m D : 13m

Timing belt type

X-axis: Timing belt driven
Side mounted motor

Z-axis: Ball screw driven
Motor straight

[Specifications]

	X-axis	Z-axis
Type of axis	BE50F-B □ -M21N- □ 0	BE30E-ST-M10B- □ 5
Stroke (in increments of 100 mm)	200 ~ 3500mm	150 ~ 1050mm
Maximum speed	1000mm/s	600mm/s (Note 1)
Positioning repeatability	±0.04mm	±0.01mm
Lead	21mm (lead converted into ball screw)	10mm
Motor output	200W	100W, with brake
Resolution	0.01mm	

Note 1: When the stroke is as given below, the maximum speed differs.

Z-axis	Stroke (mm)	Maximum speed (mm/s)
	750	500
	850	400
	950~1050	300

Acceleration/deceleration time when the maximum speed is set: 0.36 sec. or over

Maximum payload (kg) (Note 2)	Z-axis stroke									
	150mm	250mm	350mm	450mm	550mm	650mm	750mm	850mm	950mm	1050mm
	12.0	12.0	12.0	12.0	12.0	12.0	12.0	12.0	12.0	8.0

Note 2: Payload when a regenerative discharge unit (ABSU-2000) is used.

S: Right-handed

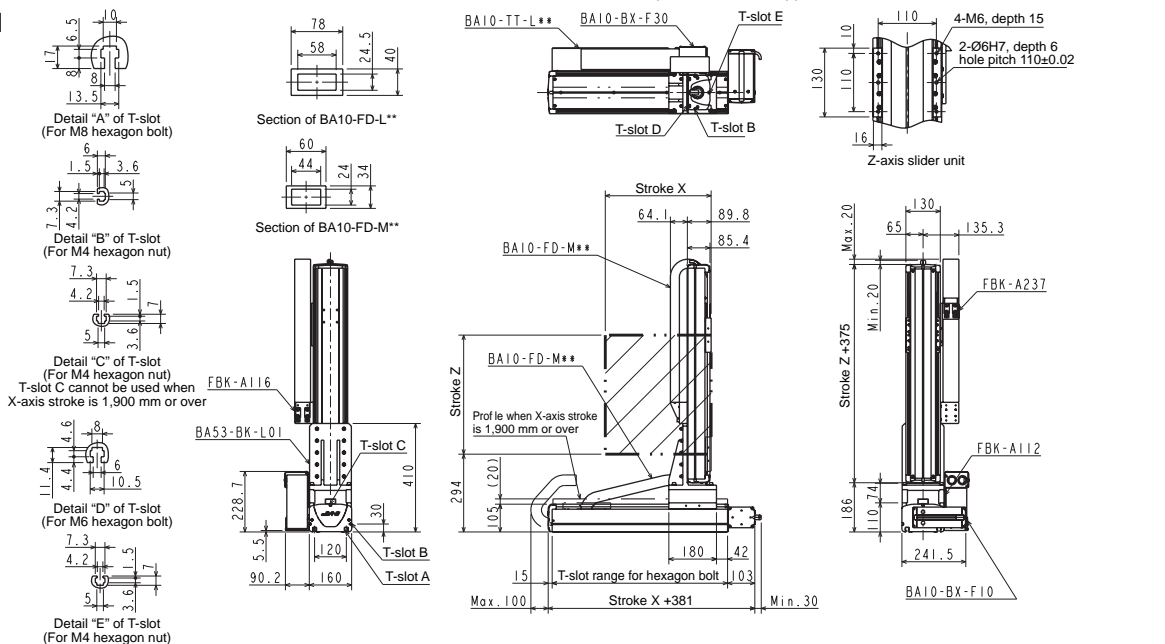

M: Left-handed

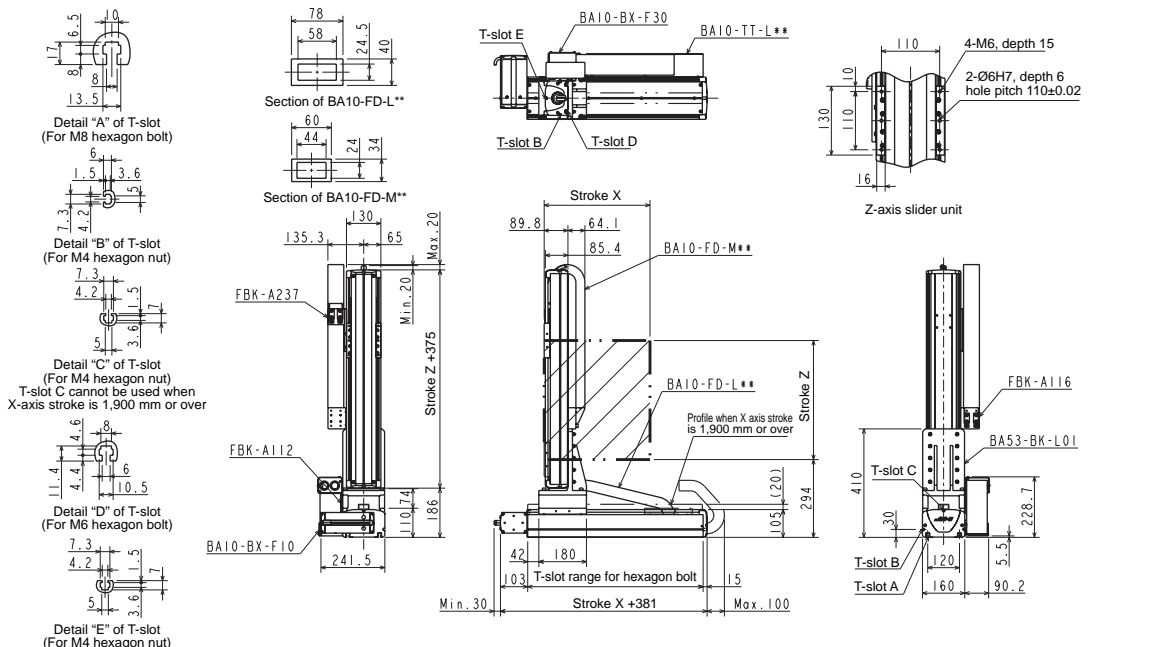

X-Z Flexible-duct Spec.

[Set designation]

BA3 - L5 - B2B S S - 40 40 00 - OF 1 3

Combined operation S: Right-handed M: Left-handed	Axis 1 stroke 20 : 200mm 90 : 900mm A0 : 1000mm H0 : 1700mm	Axis 2 stroke JO : 1800mm NO : 2200mm PO : 2300mm VO : 2900mm W0 : 3000mm W50 : 3500mm	Controller (CA25-M10) 0 : None 1 : NPN output specifications Other : See page 20	Cable length 3 : 3m 5 : 5m 7 : 7m 9 : 9m B : 11m D : 13m
---	---	--	---	--

Timing belt type

X-axis: Timing belt driven
Side mounted motor

Z-axis: Ball screw driven
Motor straight

[Specifications]

	X-axis	Z-axis
Type of axis	BE50F-B □ -M21N- □ 0	BE30F-ST-M10B- □ 0
Stroke (in increments of 100 mm)	200 ~ 3500mm	100 ~ 1000mm
Maximum speed	1000 mm/s	600 mm/s (Note 1)
Positioning repeatability	± 0.04mm	± 0.01 mm
Lead	21 mm (lead converted into ball screw)	10mm
Motor output	200W	200W, with brake
Resolution	0.01mm	

Note 1: When the stroke is as given below, the maximum speed differs.

	Stroke (mm)	Maximum speed (mm/s)
Z-axis	700	500
	800	400
	900~1000	300

Acceleration/deceleration time when the maximum speed is set: 0.36 sec. or over

Maximum payload (kg) (Note 2)	Z-axis stroke									
	100mm	200mm	300mm	400mm	500mm	600mm	700mm	800mm	900mm	1000mm
	20.0	20.0	20.0	19.0	18.0	17.0	16.0	13.0	9.0	7.0

Note 2: Payload when a regenerative discharge unit (ABSU-2000) is used.

S: Right-handed

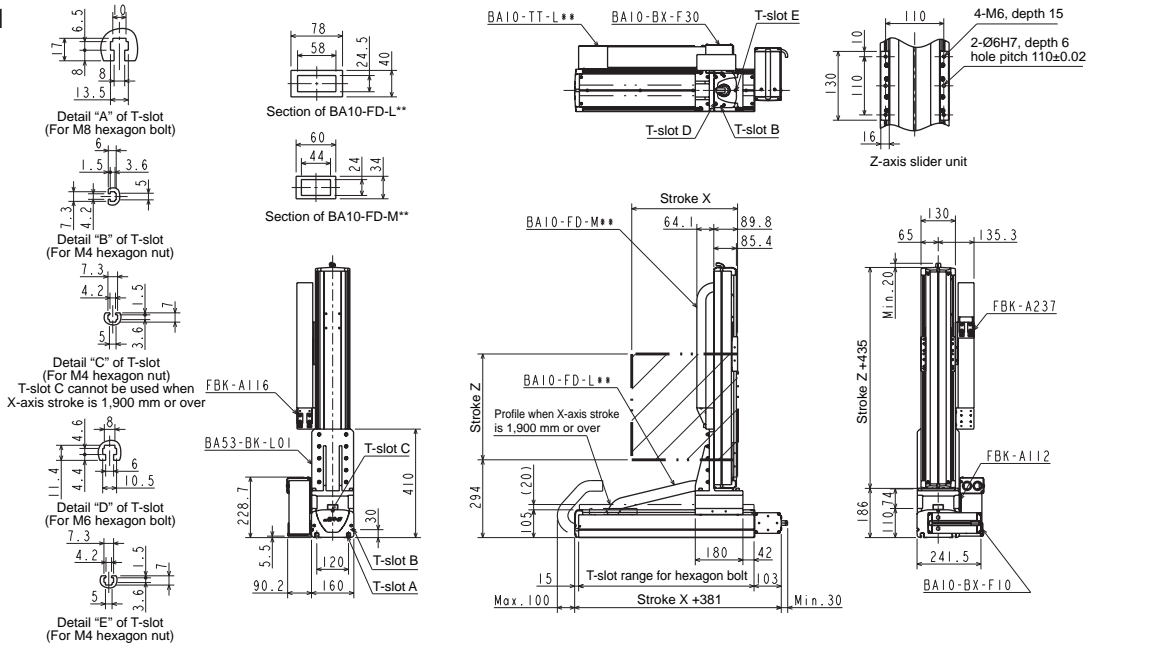

M: Left-handed

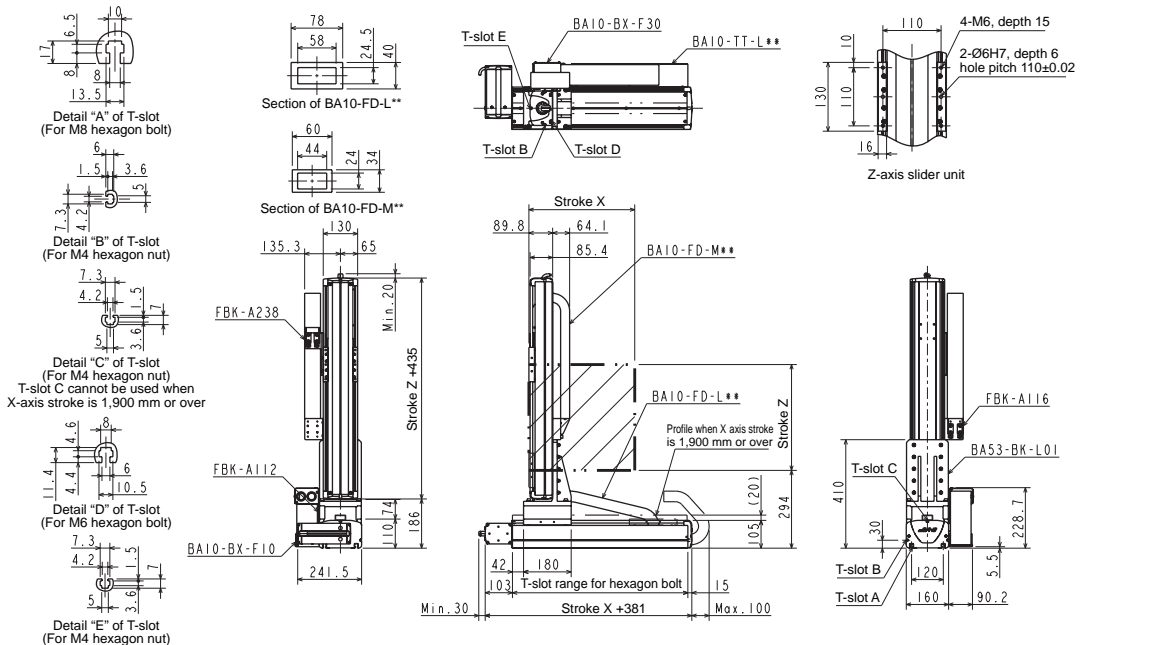

[Set designation]

BA3 - T7 - H2AR A - 40 40 00 - 00 1 3

Combined operation R: Right-handed L: Left-handed	Axis 1 stroke 05 : 50mm 70 : 700mm	Axis 2 stroke 05 : 50mm 50 : 500mm	Controller (CA25-M10) 0 : None 1 : NPN output specifications Other : See page 20	Cable length 3 : 3m 9 : 9m 5 : 5m B : 11m 7 : 7m D : 13m
---	--	--	---	---

Ball screw type

Y-axis: Ball screw driven
Motor straight

Z-axis: Ball screw driven
Motor straight

[Specifications]

	Y-axis	Z-axis
Type of axis	BET7D-ST-M12N-□□	BET5D-ST-M06B-□□
Stroke (mm) (in increments of 50 mm)	50 ~ 600, 700	50 ~ 500
Maximum speed (mm/s)	800 (Note 1)	400 (Note 1)
Positioning repeatability (mm)	± 0.02	
Lead of ball screw (mm)	12	6
Motor output	50W	50W, with brake
Resolution (mm)	0.01	

Note 1: When the stroke is as given below, the maximum speed differs.

	Stroke (mm)	Maximum speed (mm/s)
Y-axis	50~550	800
	600	680
	700	500
Z-axis	500	340

Acceleration/deceleration time when the maximum speed is set: 0.3 sec. or over

Maximum payload (kg)	Z-axis stroke									
	50mm	100mm	150mm	200mm	250mm	300mm	350mm	400mm	450mm	500mm
	3.0	3.0	3.0	3.0	3.0	3.0	2.0	2.0	1.0	1.0

R: Right-handed

Stroke X (BET7)	50	100	150	200	250	300	350	400	450	500	550	600	700
No. of holes A	4	6	6	8	8	10	10	12	12	14	14	16	18
Hole-to-hole pitch B	1	2	2	3	3	4	4	5	5	6	6	7	8

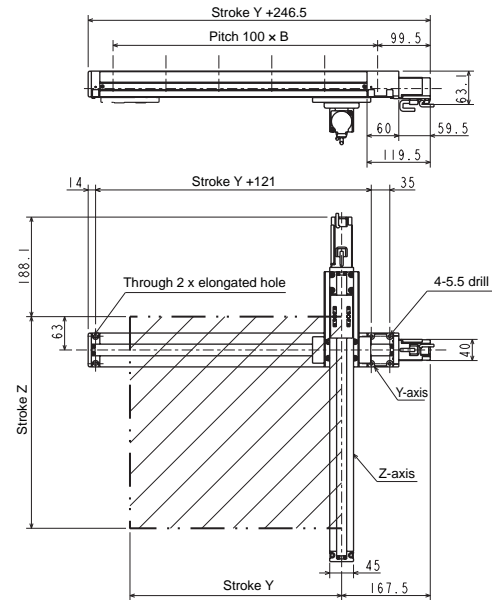
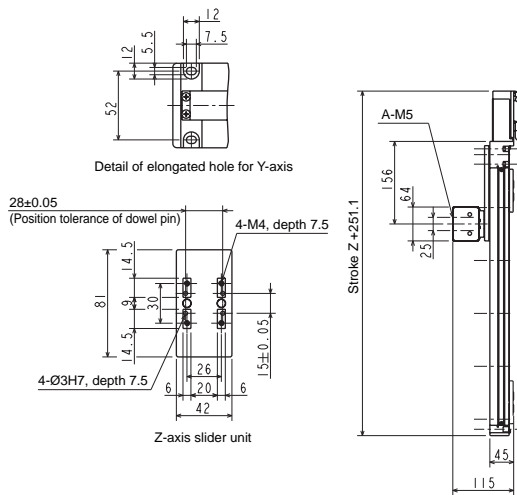

L: Left-handed

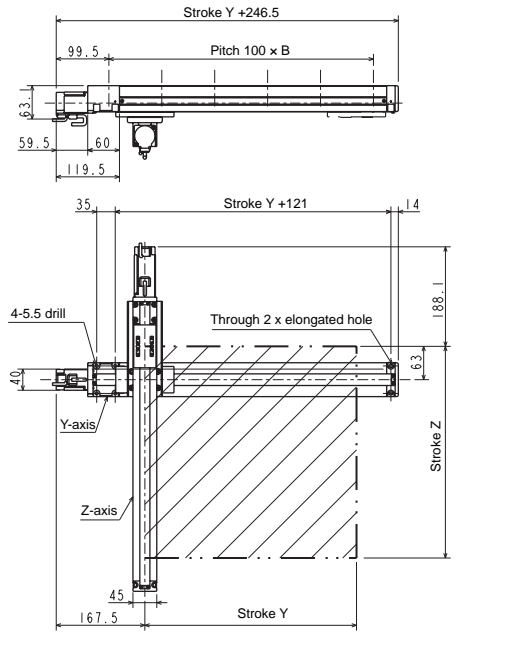

Stroke X (BET7)	50	100	150	200	250	300	350	400	450	500	550	600	700
No. of holes A	4	6	6	8	8	10	10	12	12	14	14	16	18
Hole-to-hole pitch B	1	2	2	3	3	4	4	5	5	6	6	7	8

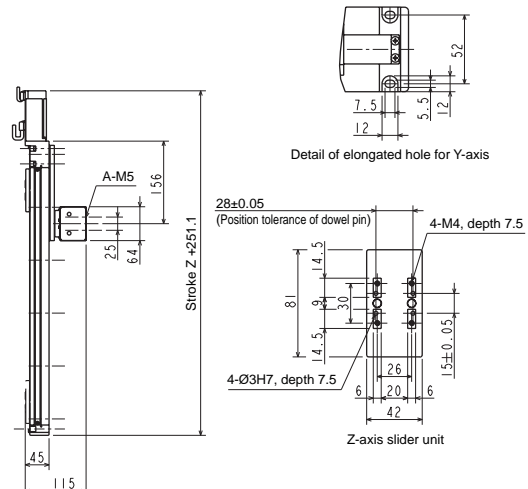

Z-Y

[Set designation]

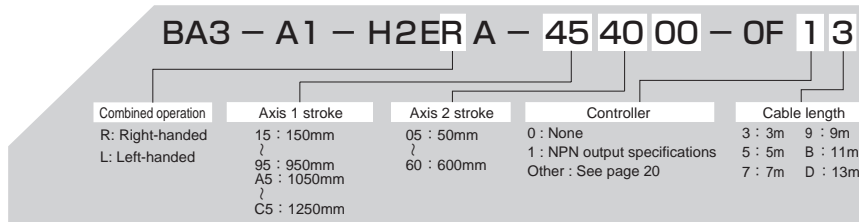

Ball screw type

Y-axis: Ball screw driven
Motor straight

Z-axis: Ball screw driven
Motor straight

[Specifications]

	Y-axis	Z-axis
Type of axis	BE10E-ST-S20N-□5	BET7D-ST-M06B-□□
Stroke (mm) (in increments of 100 mm for Y-axis, 50 mm for Z-axis)	150 ~ 1250	50 ~ 600
Maximum speed (mm/s)	1200 (Note 1)	400 (Note 1)
Positioning repeatability (mm)	±0.01	±0.02
Lead of ball screw (mm)	20	6
Motor output	100W	50W with brake
Resolution (mm)	0.01	

Note 1: When the stroke is as given below, the maximum speed differs.

	Stroke (mm)	Maximum speed (mm/s)
Y-axis	750	1000
	850	800
	950~1050	600
	1150~1250	400
Z-axis	600	340

Acceleration/deceleration time when the maximum speed is set: 0.36 sec. or over

Maximum payload (kg)	Z-axis stroke											
	50mm	100mm	150mm	200mm	250mm	300mm	350mm	400mm	450mm	500mm	550mm	600mm
	4.0	4.0	4.0	4.0	4.0	4.0	4.0	4.0	3.5	3.5	2	2

R: Right-handed

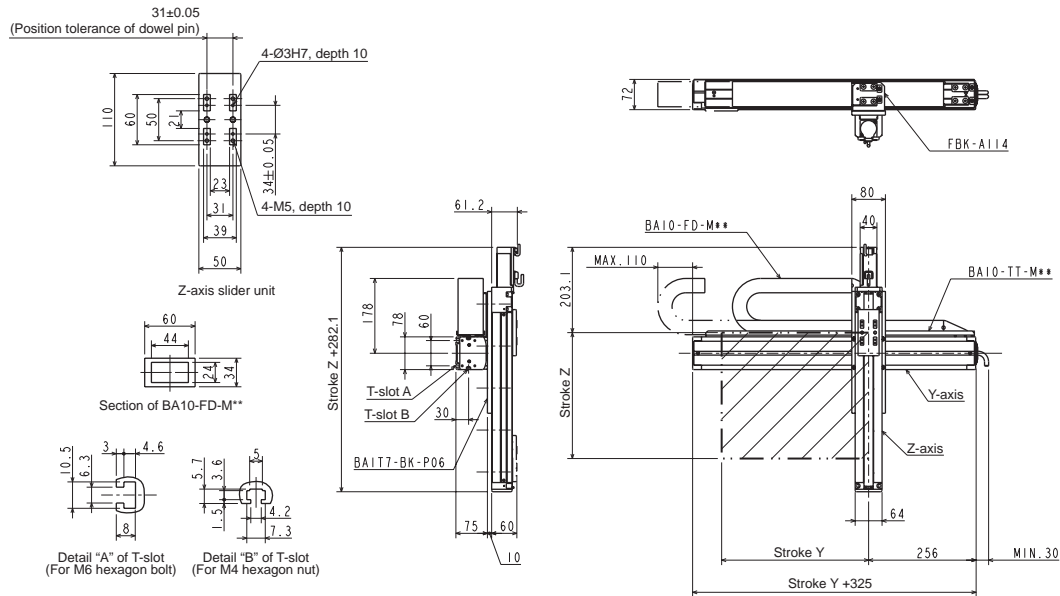

L: Left-handed

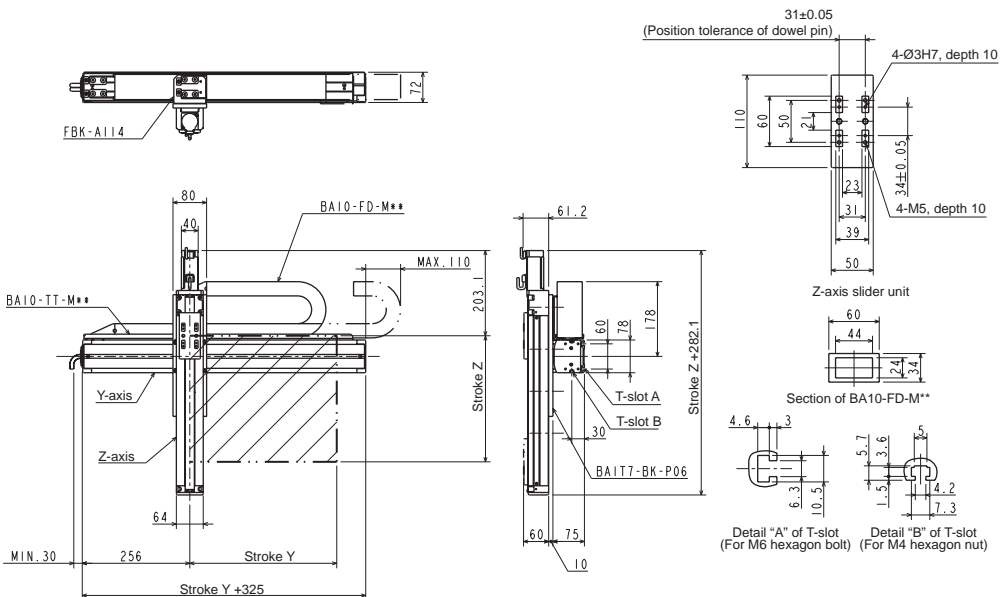

[Set designation]

BA3 - A1 - H2A R C - 40 45 00 - OF 1 3

Combined operation R: Right-handed L: Left-handed	Axis 1 stroke 10 : 100mm ? : 900mm A0 : 1000mm C0 : 1200mm	Axis 2 stroke 15 : 150mm ? : 550mm	Controller (CA25-M10) 0 : None 1 : NPN output specifications Other : See page 20	Cable length 3 : 3m 9 : 9m 5 : 5m B : 11m 7 : 7m D : 13m
---	--	--	---	---

Ball screw type

- Y-axis: Ball screw driven
Motor straight
- Z-axis: Ball screw driven
Side mounted motor

[Specifications]

	Y-axis	Z-axis
Type of axis	BE10E-ST-M20N-□ 0	BE10E-U □ -S10B-□ 5
Stroke (in increments of 100 mm)	100 ~ 1200mm	150 ~ 550mm
Maximum speed	1200mm/s (Note 1)	600mm/s
Positioning repeatability	± 0.01mm	
Lead of ball screw	20mm	10mm
Motor output	100W	100W, with brake
Resolution	0.01mm	

Note 1: When the stroke is as given below, the maximum speed differs.

Y-axis	Stroke (mm)	Maximum speed (mm/s)
	700	1000
	800	800
	900~1000	600
	1100~1200	400

Acceleration/deceleration time when the maximum speed is set: 0.36 sec. or over

Maximum payload (kg) (Note 2)	Z-axis stroke				
	150mm	250mm	350mm	450mm	550mm
	8.0	8.0	6.5	5.0	3.0

Note 2: Payload when a regenerative discharge unit (ABSU-2000) is used.

R: Right-handed

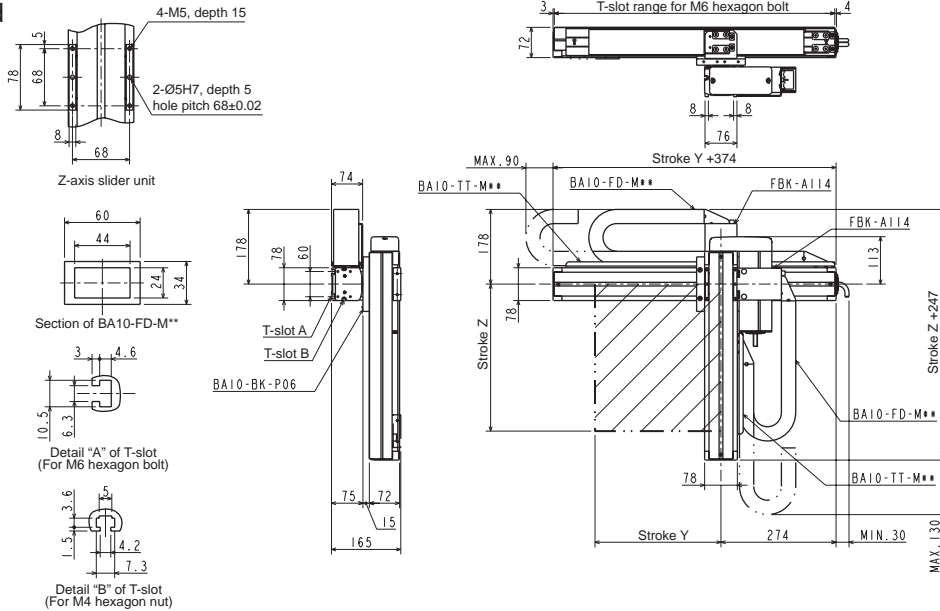

L: Left-handed

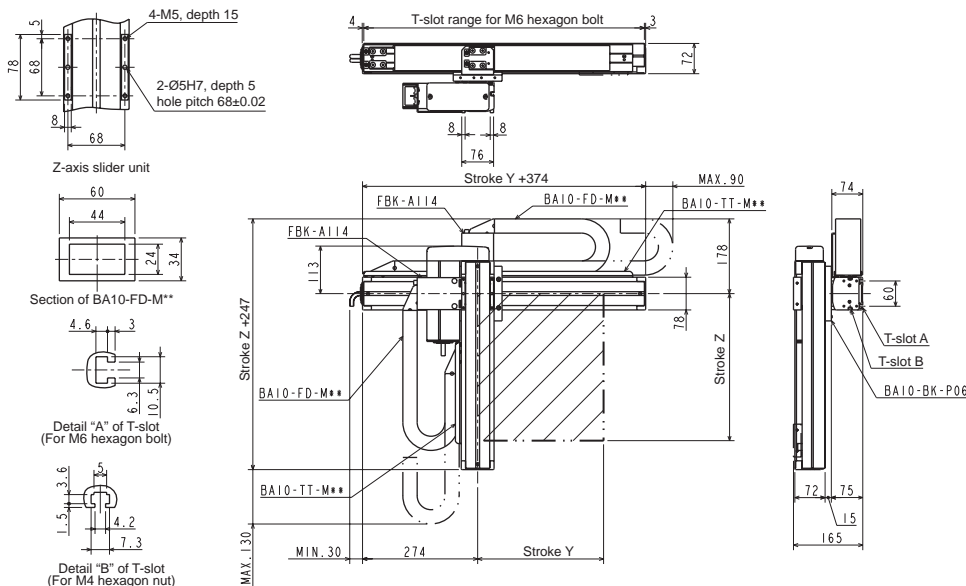

[Set designation]

BA3 - A3 - H2AR C - 45 40 00 - OF 1 3

Combined operation R: Right-handed L: Left-handed	Axis 1 stroke 15 : 150mm 95 : 950mm A5 : 1050mm C5 : 1250mm	Axis 2 stroke 10 : 100mm 80 : 800mm	Controller (CA25-M10) 0 : None 1 : NPN output specifications Other : See page 20	Cable length 3 : 3m 9 : 9m 5 : 5m B : 11m 7 : 7m D : 13m
---	---	---	---	---

Ball screw type

- Y-axis: Ball screw driven
Motor straight
- Z-axis: Ball screw driven
Side mounted motor

[Specifications]

	Y-axis	Z-axis
Type of axis	BE30E-ST-M20N-□ 5	BE10E-U □ -M10B-□ 0
Stroke (in increments of 100 mm)	150 ~ 1250mm	100 ~ 800mm
Maximum speed	1200mm/s (Note 1)	600mm/s (Note 1)
Positioning repeatability	±0.01mm	
Lead of ball screw	20mm	10mm
Motor output	100W	100W, with brake
Resolution	0.01mm	

Note 1: When the stroke is as given below, the maximum speed differs.

	Stroke (mm)	Maximum speed (mm/s)
Y-axis	750	1000
	850	800
	950~1050	600
	1150~1250	400
Z-axis	700	500
	800	400

Acceleration/deceleration time when the maximum speed is set: 0.48 sec. or over

Maximum payload (kg) (Note 2)	Z-axis stroke							
	100mm	200mm	300mm	400mm	500mm	600mm	700mm	800mm
	12.0	11.0	9.0	9.0	6.0	5.0	1.0	1.0

Note 2: Payload when a regenerative discharge unit (ABSU-2000) is used.

R: Right-handed

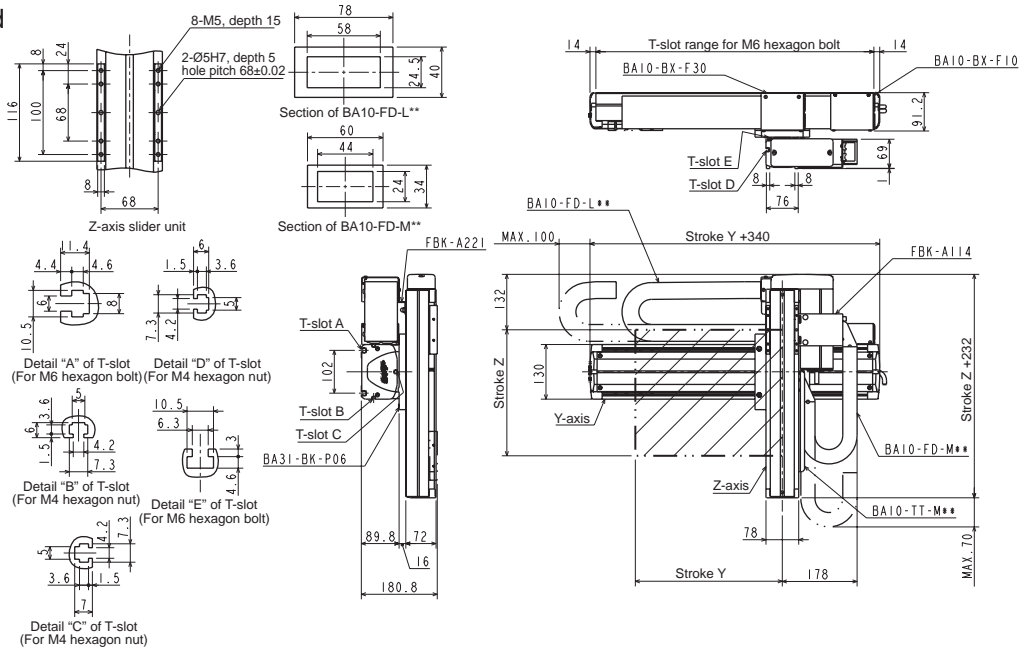

L: Left-handed

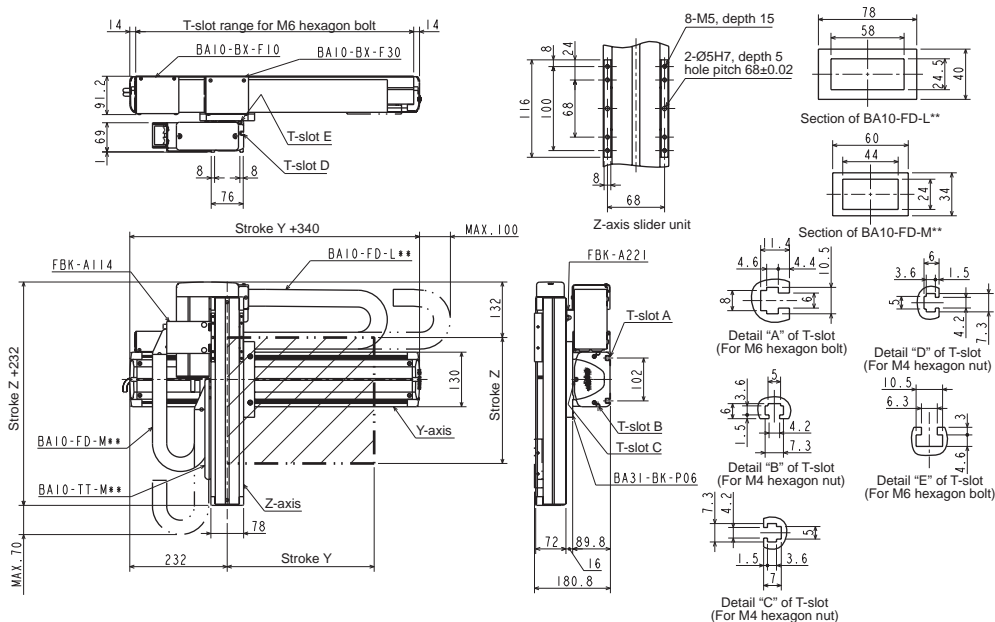

[Set designation]

BA3 - A5 - H2AR C - 40 40 00 - OF 1 3

Combined operation R: Right-handed L: Left-handed	Axis 1 stroke 20 : 200mm 90 : 900mm A0 : 1000mm G0 : 1600mm	Axis 2 stroke 10 : 100mm 90 : 900mm A0 : 1000mm	Controller (CA25-M10) 0 : None 1 : NPN output specifications Other : See page 20	Cable length 3 : 3m 9 : 9m 5 : 5m B : 11m 7 : 7m D : 13m
---	---	--	---	---

Ball screw type

- Y-axis: Ball screw driven
Motor straight
- Z-axis: Ball screw driven
Side mounted motor

Note 1: When the stroke is as given below, the maximum speed differs.

[Specifications]

	Y-axis	Z-axis
Type of axis	BE50F-ST-M20N-□ 0	BE30E-U □ -M10B-□ 0
Stroke (in increments of 100 mm)	200 ~ 1600mm	100 ~ 1000mm
Maximum speed	1200mm/s (Note 1)	600mm/s (Note 1)
Positioning repeatability	± 0.01mm	
Lead of ball screw	20mm	10mm
Motor output	200W	100W, with brake
Resolution	0.01mm	

Acceleration/deceleration time when the maximum speed is set: 0.36 sec. or over

	Stroke (mm)	Maximum speed (mm/s)
Y-axis	700~800	1100
	900~1000	1000
	1100~1200	700
	1300	500
	1400	400
	1500	300
Z-axis	1600	300
	700	500
	800	400
	900~1000	300

Maximum payload (kg) (Note 2)	Z-axis stroke									
	100mm	200mm	300mm	400mm	500mm	600mm	700mm	800mm	900mm	1000mm
	12.0	12.0	12.0	12.0	12.0	12.0	12.0	12.0	12.0	12.0

Note 2: Payload when a regenerative discharge unit (ABSU-2000) is used.

R: Right-handed

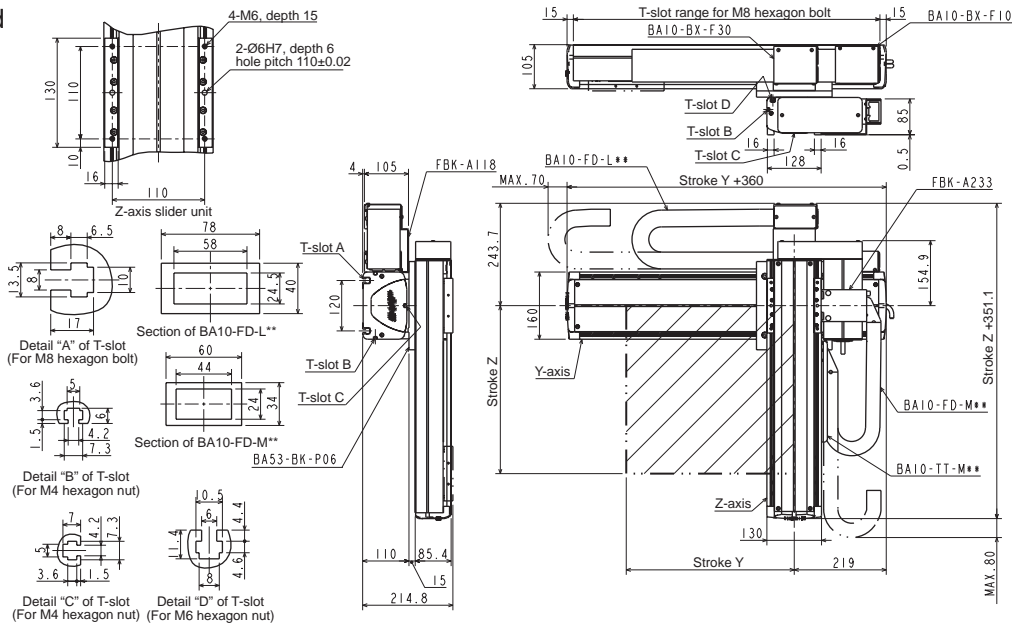

L: Left-handed

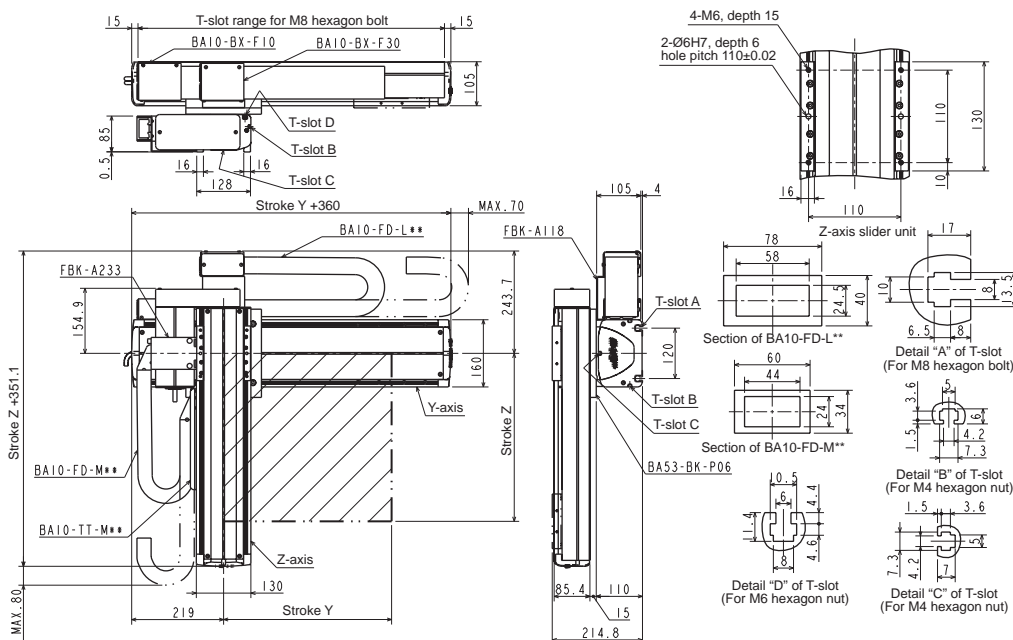

[Set designation]

BA3 - L1 - H2JR S - 45 40 00 - OF 1 3

Combined operation	Axis 1 stroke		Axis 2 stroke	Controller (CA25-M10)	Cable length			
R: Right-handed	15 : 150mm	J5 : 1850mm	05 : 50mm	0 : None	3 : 3m	9 : 9m		
L: Left-handed	95 : 950mm	N5 : 2250mm	60 : 600mm	1 : NPN output specifications	5 : 5m	B : 11m		
	A5 : 1050mm	P5 : 2350mm		Other : See page 20	7 : 7m	D : 13m		
	H5 : 1750mm	R5 : 2550mm						

Timing belt type

Y-axis: Timing belt driven
Side mounted motor

Z-axis: Ball screw driven
Motor straight

[Specifications]

	Y-axis	Z-axis
Type of axis	BE10E-B □ -S21N- □ 5	BET7D-ST-M06B- □ □
Stroke (mm) (in increments of 100 mm for Y-axis, 50 mm for Z-axis)	150 ~ 2550	50 ~ 600
Maximum speed (mm/s)	1000	400 (Note 1)
Positioning repeatability (mm)	±0.04	±0.02
Lead of ball screw (mm)	21 (lead converted into ball screw)	6
Motor output	100W	50W, with brake
Resolution (mm)	0.01	

Note 1: When the stroke is as given below, the maximum speed differs.

	Stroke (mm)	Maximum speed (mm/s)
Z-axis	600	340

Acceleration/deceleration time when the maximum speed is set: 0.36 sec. or over

Maximum payload (kg)	Z-axis stroke											
	50mm	100mm	150mm	200mm	250mm	300mm	350mm	400mm	450mm	500mm	550mm	600mm
	4.0	4.0	4.0	4.0	4.0	4.0	4.0	4.0	3.5	3.5	2.0	2.0

R: Right-handed

The values in parentheses are applicable when the Y-axis stroke is 1,050 mm or less.

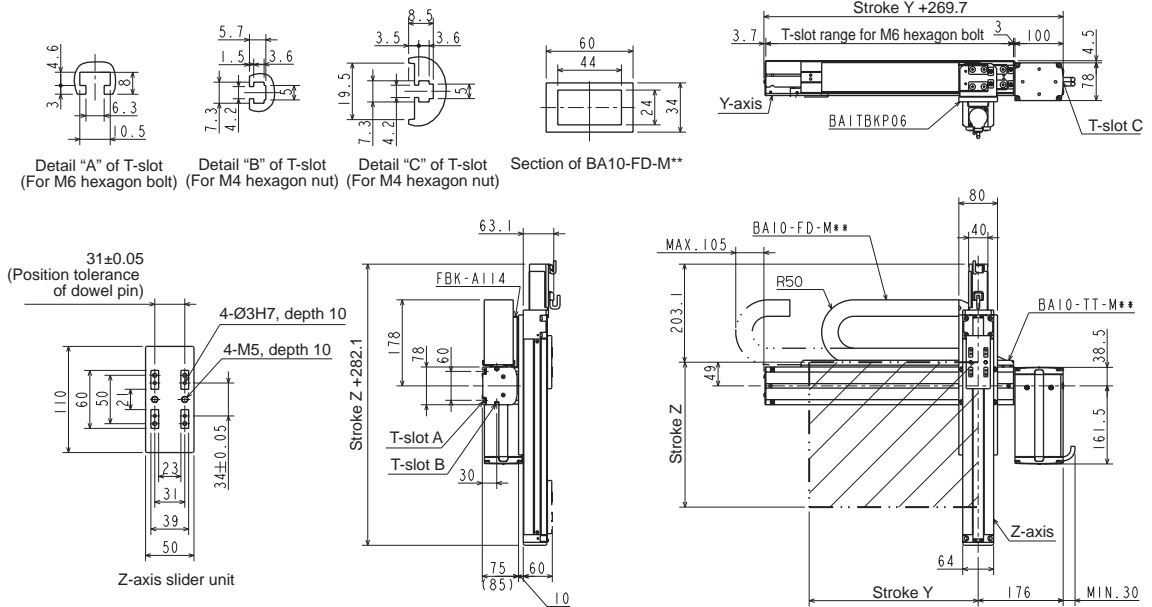

L: Left-handed

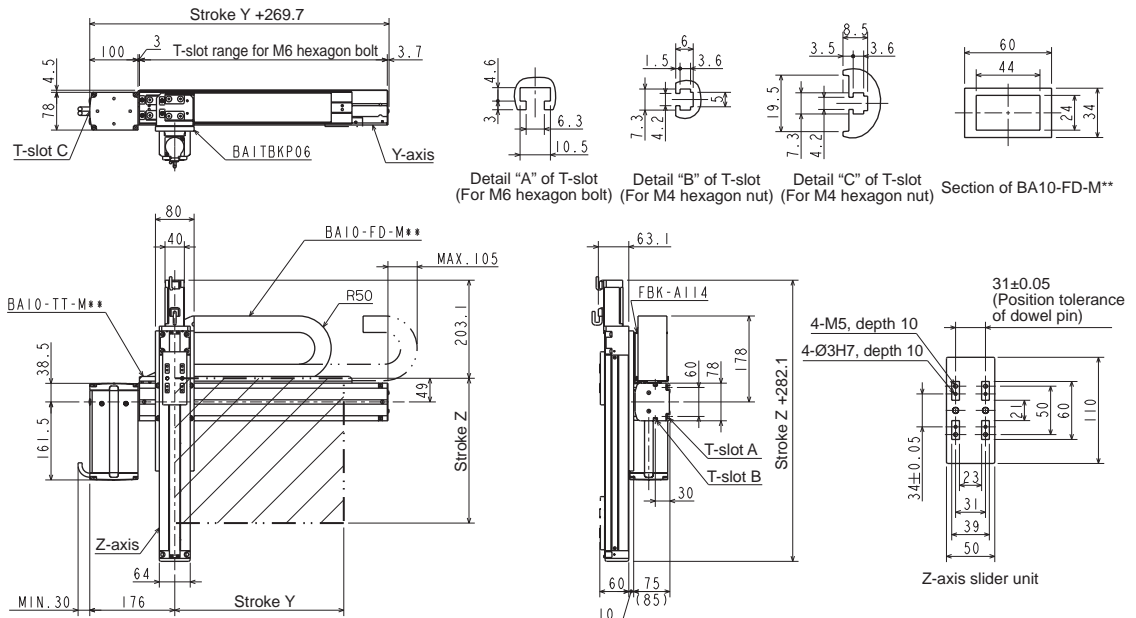

[Set designation]

BA3 - L1 - H2A R W - 40 45 00 - OF 1 3

Combined operation	Axis 1 stroke	Axis 2 stroke	Controller (CA25-M10)	Cable length
R: Right-handed L: Left-handed	10 : 100mm 90 : 900mm A0 : 1000mm H0 : 1700mm	J0 : 1800mm N0 : 2200mm P0 : 2300mm R0 : 2500mm	15 : 150mm 55 : 550mm	0 : None 1 : NPN output specifications Other : See page 20
				3 : 3m 5 : 5m 7 : 7m
				9 : 9m B : 11m D : 13m

Timing belt type

Y-axis: Timing belt driven
Side mounted motor

Z-axis: Ball screw driven
Side mounted motor

[Specifications]

	Y-axis	Z-axis
Type of axis	BE10E-B □ -M21N- □ 0	BE10E-U □ -S10B- □ 5
Stroke (in increments of 100 mm)	100 ~ 2500mm	150 ~ 550mm
Maximum speed	1000mm/s	600mm/s
Positioning repeatability	± 0.04mm	± 0.01mm
Lead of ball screw	21mm (lead converted into ball screw)	10mm
Motor output	100W	100W, with brake
Resolution	0.01mm	

Acceleration/deceleration time when the maximum speed is set: 0.48 sec. or over

Maximum payload (kg)	Z-axis stroke				
	150mm	250mm	350mm	450mm	550mm
	8.0	8.0	6.0	5.0	3.0

R: Right-handed

The values in parentheses are applicable when the Y-axis stroke is 1,050 mm or less.

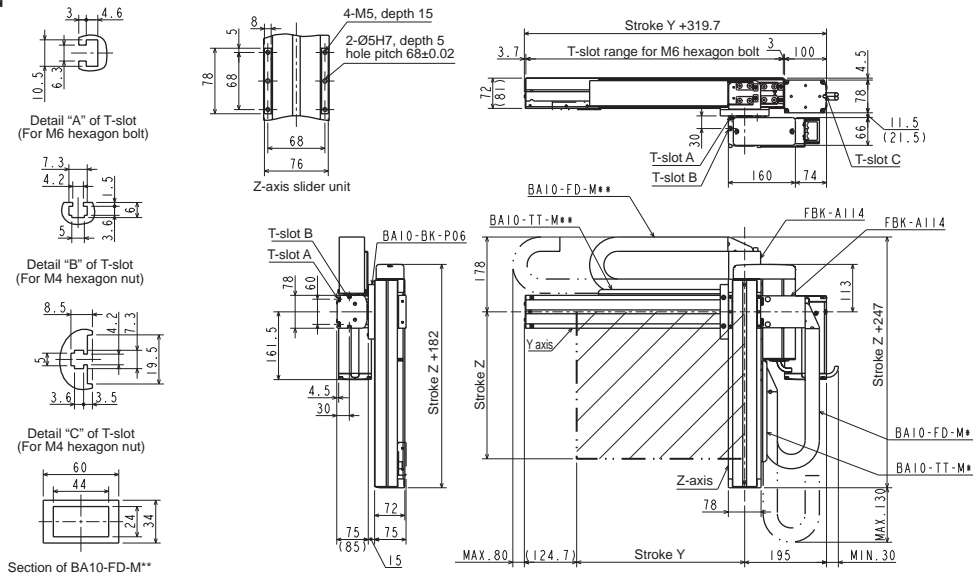

L: Left-handed

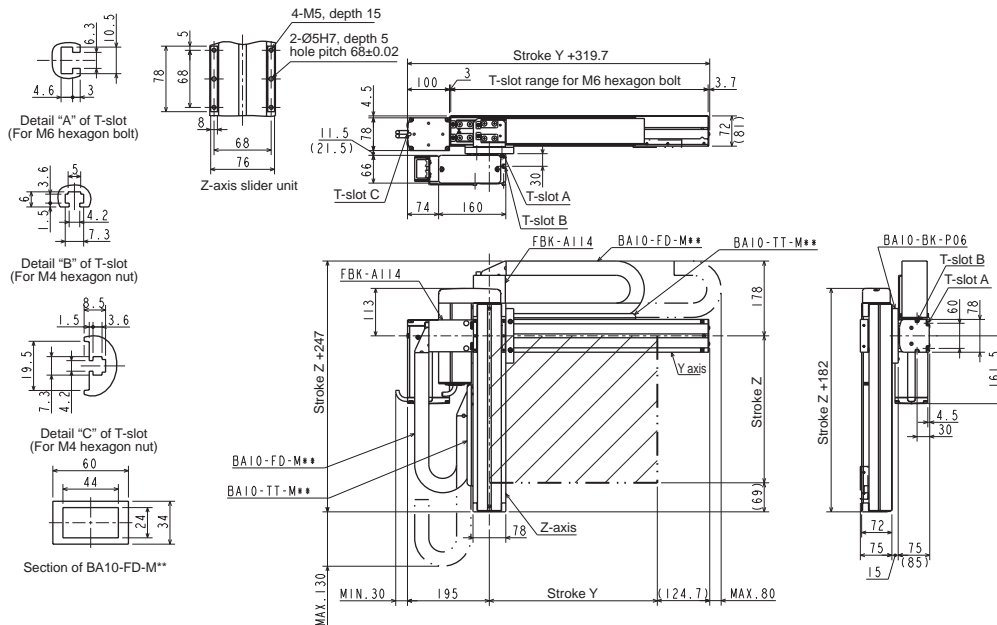

[Set designation]

BA3 - L3 - H2A R W - 40 40 00 - OF 1 3

Combined operation	Axis 1 stroke	Axis 2 stroke	Controller (CA25-M10)	Cable length
R: Right-handed L: Left-handed	10 : 100mm 90 : 900mm A0 : 1000mm H0 : 1700mm	JO : 1800mm NO : 2200mm PO : 2300mm VO : 2900mm W0 : 3000mm W20 : 3200mm	10 : 100mm 80 : 800mm	0 : None 1 : NPN output specifications Other : See page 20
				3 : 3m 9 : 9m 5 : 5m B : 11m 7 : 7m D : 13m

Timing belt type

Y-axis: Timing belt driven
Side mounted motor

Z-axis: Ball screw driven
Motor straight

[Specifications]

	Y-axis	Z-axis
Type of axis	BE30E-B □ -M21N- □ 0	BE10E-U □ -M10B- □ 0
Stroke (in increments of 100 mm)	100 ~ 3200mm	100 ~ 800mm
Maximum speed	1000mm/s	600mm/s (Note 1)
Positioning repeatability	± 0.04mm	± 0.01mm
Lead	21 mm (lead converted into ball screw)	10mm
Motor output	100W	100W, with brake
Resolution	0.01mm	

Note 1: When the stroke is as given below, the maximum speed differs.

Z-axis	Stroke (mm)	Maximum speed (mm/s)
	700	500
	800	400

Acceleration/deceleration time when the maximum speed is set: 0.48 sec. or over

Maximum payload (kg)	Z-axis stroke							
	100mm	200mm	300mm	400mm	500mm	600mm	700mm	800mm
	6.0	6.0	5.0	4.0	4.0	3.0	1.0	1.0

R: Right-handed

The values in parentheses are applicable when the Y-axis stroke is 1,850 mm or less.

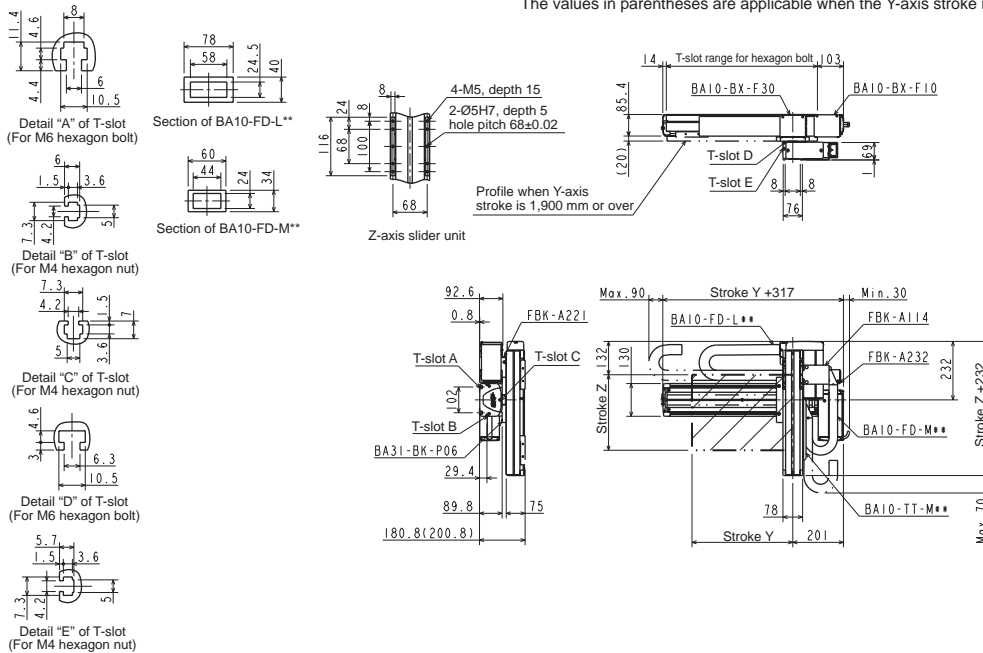

L: Left-handed

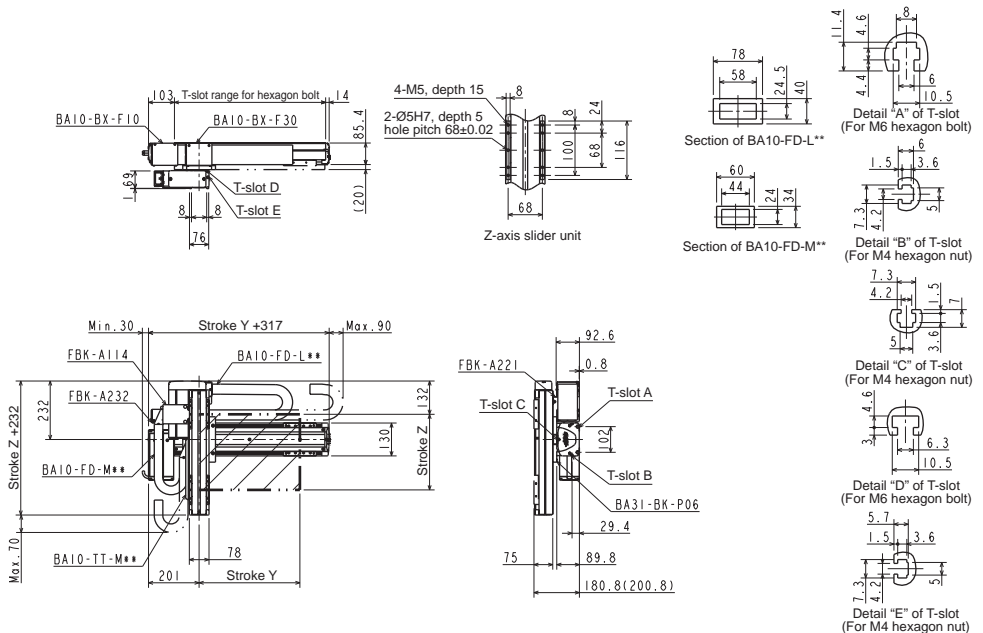

[Set designation]

BA3 - L3 - H2B R W - 40 40 00 - OF 1 3

Combined operation	Axis 1 stroke	Axis 2 stroke	Controller (CA25-M10)	Cable length
R: Right-handed	10 : 100mm J0 : 1800mm	10 : 100mm	0 : None	3 : 3m 9 : 9m
L: Left-handed	90 : 900mm A0 : 1000mm H0 : 1700mm	90 : 900mm A0 : 1000mm	1 : NPN output specifications Other : See page 20	5 : 5m 7 : 7m B : 11m D : 13m
	N0 : 2200mm P0 : 2300mm V0 : 2900mm W0 : 3000mm W20 : 3200mm			

Timing belt type

Y-axis: Timing belt driven
Side mounted motor

Z-axis: Ball screw driven
Side mounted motor

[Specifications]

	Y-axis	Z-axis
Type of axis	BE30F-B □ -M21N- □ 0	BE10E-U □ -M10B- □ 0
Stroke (in increments of 100 mm)	100 ~ 3200mm	100 ~ 1000mm
Maximum speed	1000mm/s	600mm/s (Note 1)
Positioning repeatability	± 0.04mm	± 0.01mm
Lead	21mm (lead converted into ball screw)	10mm
Motor output	200W	100W, with brake
Resolution	0.01mm	

Note 1: When the stroke is as given below, the maximum speed differs.

	Stroke (mm)	Maximum speed (mm/s)
Z-axis	700	500
	800	400
	900~1000	300

Acceleration/deceleration time when the maximum speed is set: 0.36 sec. or over

Maximum payload (kg) (Note 2)	Z-axis stroke									
	100mm	200mm	300mm	400mm	500mm	600mm	700mm	800mm	900mm	1000mm
	12.0	12.0	12.0	12.0	12.0	12.0	10.0	5.0	4.0	4.0

Note 2: Payload when a regenerative discharge unit (ABSU-2000) is used.

R: Right-handed

The values in parentheses are applicable when the Y-axis stroke is 1,850 mm or less.

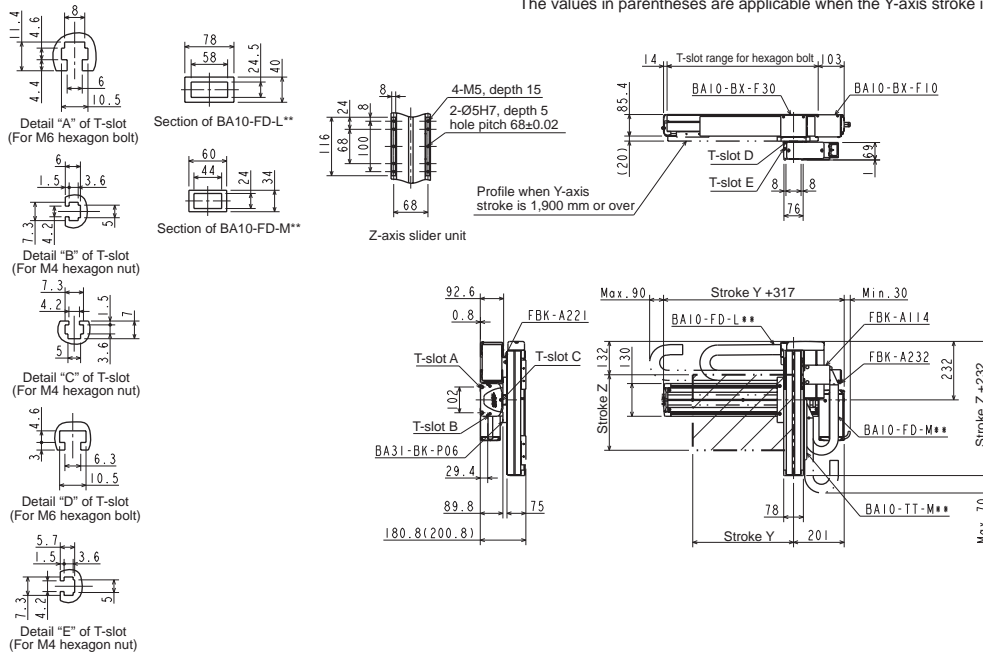

L: Left-handed

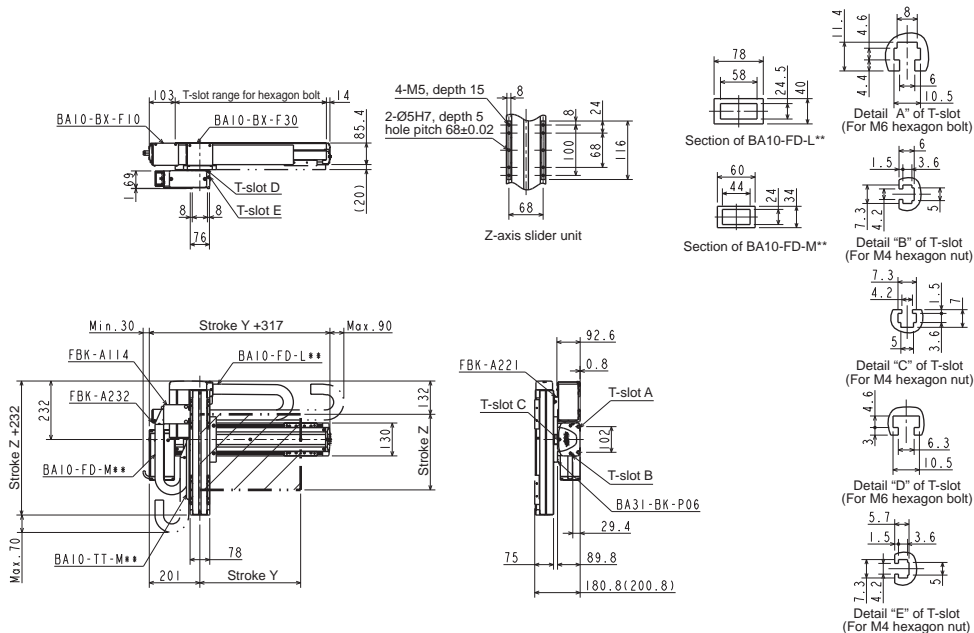

[Set designation]

BA3 - L5 - H2A R W - 40 40 00 - OF 1 3

Combined operation	Axis 1 stroke	Axis 2 stroke	Controller (CA25-M10)	Cable length
R: Right-handed	20 : 200mm	JO : 1800mm	10 : 100mm	0 : None
L: Left-handed	90 : 900mm	NO : 2200mm	1 : NPN output specifications	3 : 3m 9 : 9m
	A0 : 1000mm	PO : 2300mm	Other : See page 20	5 : 5m B : 11m
	H0 : 1700mm	V0 : 2900mm		7 : 7m D : 13m
		W0 : 3000mm		
		W50 : 3500mm		

Timing belt type

Y-axis: Timing belt driven
Side mounted motor

Z-axis: Ball screw driven
Side mounted motor

[Specifications]

	Y-axis	Z-axis
Type of axis	BE50F-B □ -M21N- □ 0	BE30E-U □ -M10B- □ 0
Stroke (in increments of 100 mm)	200 ~ 3500mm	100 ~ 1000mm
Maximum speed	1000mm/s	600mm/s (Note 1)
Positioning repeatability	± 0.04mm	± 0.01mm
Lead	21mm (lead converted into ball screw)	10mm
Motor output	200W	100W, with brake
Resolution	0.01mm	

Note 1: When the stroke is as given below, the maximum speed differs.

	Stroke (mm)	Maximum speed (mm/s)
Z-axis	700	500
	800	400
	900~1000	300

Acceleration/deceleration time when the maximum speed is set: 0.36 sec. or over

Maximum payload (kg) (Note 2)	Z-axis stroke									
	100mm	200mm	300mm	400mm	500mm	600mm	700mm	800mm	900mm	1000mm
	12.0	12.0	12.0	12.0	12.0	12.0	12.0	12.0	12.0	12.0

Note 2: Payload when a regenerative discharge unit (ABSU-2000) is used.

R: Right-handed

The values in parentheses are applicable when the Y-axis stroke is 1,850 mm or less.

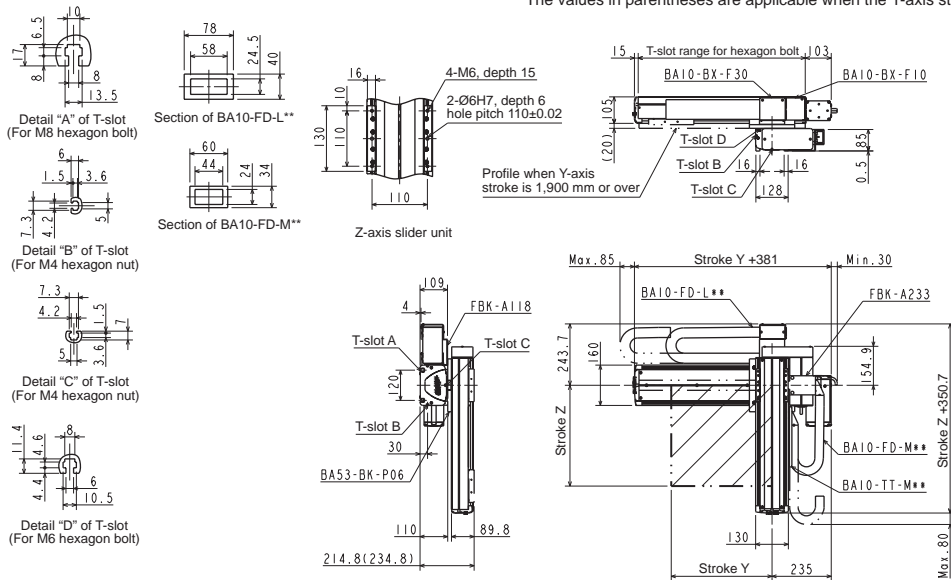

L: Left-handed

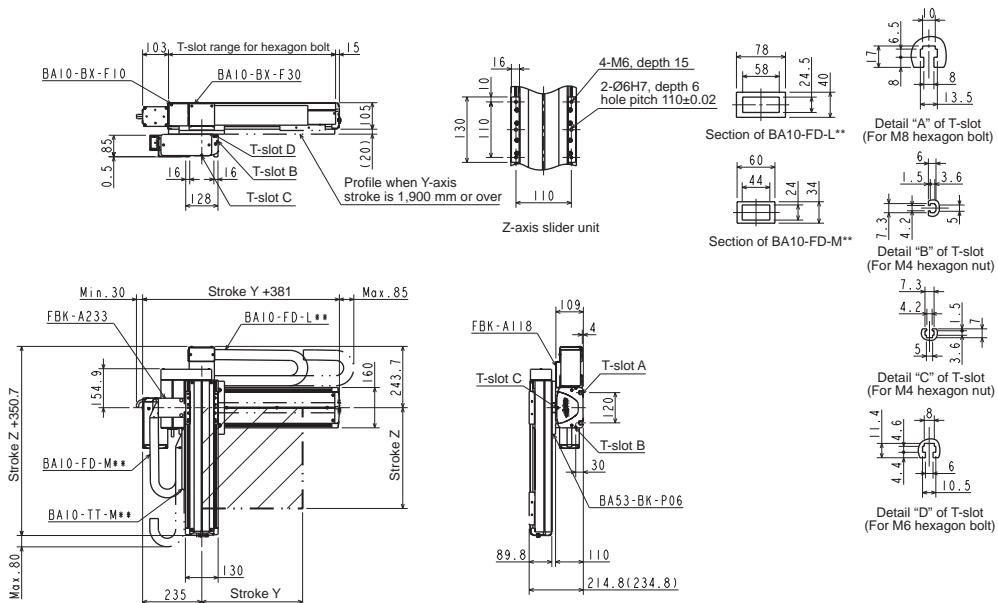

[Set designation]

BA3 - L5 - H2B R W - 40 40 00 - OF 1 3

Combined operation	Axis 1 stroke	Axis 2 stroke	Controller (CA25-M10)	Cable length	
R: Right-handed	20 : 200mm 90 : 900mm A0 : 1000mm H0 : 1700mm	JO : 1800mm NO : 2200mm PO : 2300mm VO : 2900mm W0 : 3000mm W60 : 3500mm	10 : 100mm 90 : 900mm A0 : 1000mm	0 : None 1 : NPN output specifications Other : See page 20	3 : 3m 9 : 9m 5 : 5m 7 : 7m B : 11m D : 13m

Timing belt type

Y-axis: Timing belt driven
Side mounted motor

Z-axis: Ball screw driven
Side mounted motor

[Specifications]

	Y-axis	Z-axis
Type of axis	BE50F-B □ -M21N- □ 0	BE30F-U □ -M10B- □ 0
Stroke (in increments of 100 mm)	200 ~ 3500mm	100 ~ 1000mm
Maximum speed	1000mm/s	600mm/s (Note 1)
Positioning repeatability	± 0.04mm	± 0.01mm
Lead	21mm (lead converted into ball screw)	10mm
Motor output	200W	200W, with brake
Resolution	0.01mm	

Note 1: When the stroke is as given below, the maximum speed differs.

	Stroke (mm)	Maximum speed (mm/s)
Z-axis	700	500
	800	400
	900~1000	300

Acceleration/deceleration time when the maximum speed is set: 0.36 sec. or over

Maximum payload (kg) (Note 2)	Z-axis stroke									
	100mm	200mm	300mm	400mm	500mm	600mm	700mm	800mm	900mm	1000mm
	20.0	20.0	20.0	20.0	20.0	20.0	19.0	17.0	16.0	15.0

Note 2: Payload when a regenerative discharge unit (ABSU-2000) is used.

R: Right-handed

The values in parentheses are applicable when the Y-axis stroke is 1,850 mm or less.

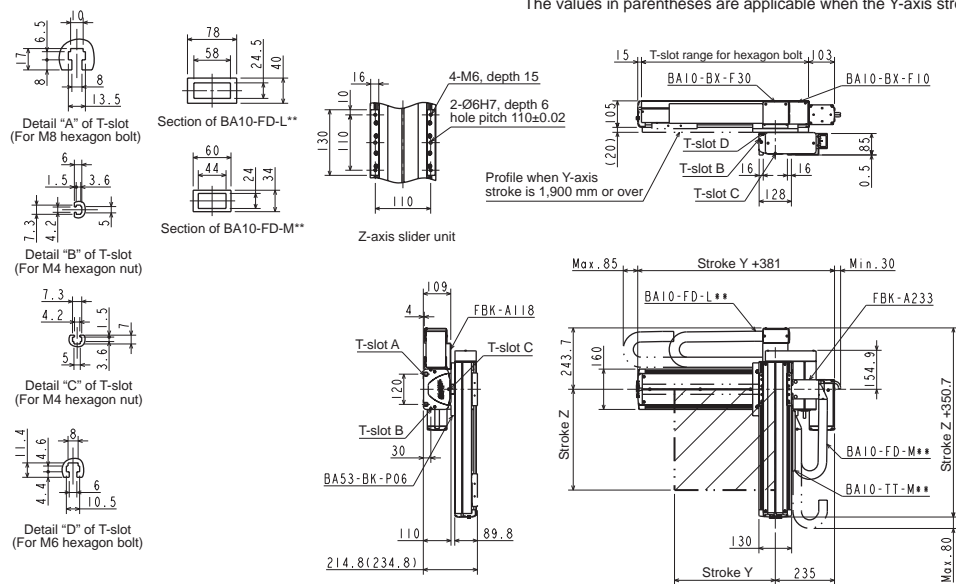

L: Left-handed

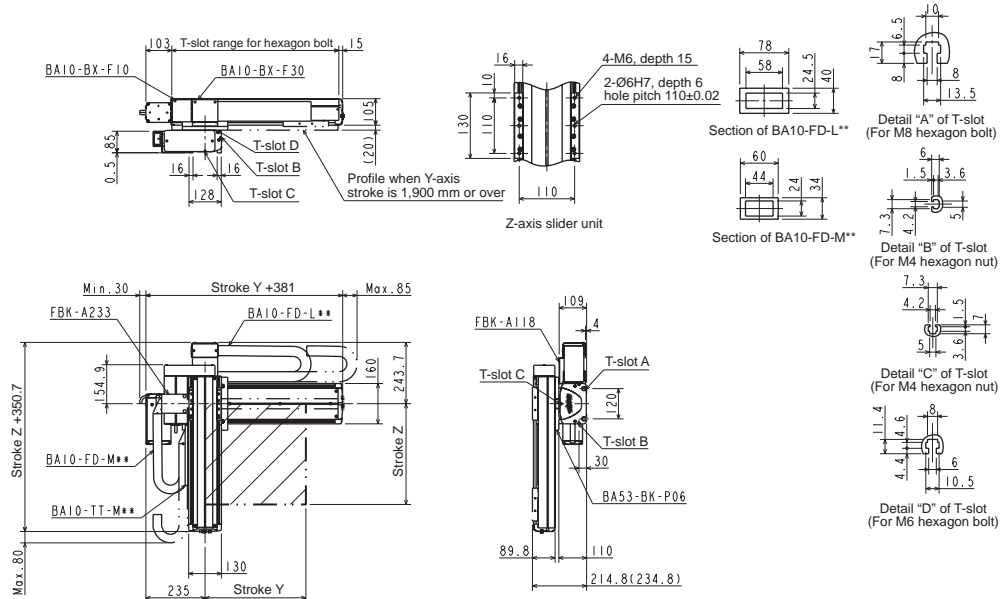

[Set designation]

BA3 - A1 - C2A RA - 40 45 00 - OF 1 3

Combined operation R: Right-handed L: Left-handed	Axis 1 stroke 10 : 100mm 90 : 900mm A0 : 1000mm	Axis 2 stroke 15 : 150mm 65 : 650mm	Controller (CA25-M10) 0 : None 1 : NPN output specifications Other : See page 20	Cable length 3 : 3m 9 : 9m 5 : 5m B : 11m 7 : 7m D : 13m
---	--	---	---	---

Ball screw type

Z-axis: Ball screw driven
Motor straight

Y-axis: Ball screw driven
Motor straight

[Specifications]

	Z-axis	Y-axis
Type of axis	BE10E-ST-M05B-□ 0	BE10E-ST-S20N-□ 5
Stroke (in increments of 100 mm)	100 ~ 1000mm	150 ~ 650mm
Maximum speed	300mm/s (Note 1)	1200mm/s
Positioning repeatability	± 0.01mm	
Lead of ball screw	5mm	20mm
Motor output	100W, with brake	100W
Resolution	0.01mm	

Note 1: When the stroke is as given below, the maximum speed differs.

Z-axis	Stroke (mm)	Maximum speed (mm/s)
	700	250
	800	200
	900~1000	150

Acceleration/deceleration time when the maximum speed is set: 0.36 sec. or over

Maximum payload (kg) (Note 2)	Y-axis stroke					
	150mm	250mm	350mm	450mm	550mm	650mm
	15.0	12.0	9.0	6.5	5.0	3.5

Note 2: Payload when a regenerative discharge unit (ABSU-2000) is used.

R: Right-handed

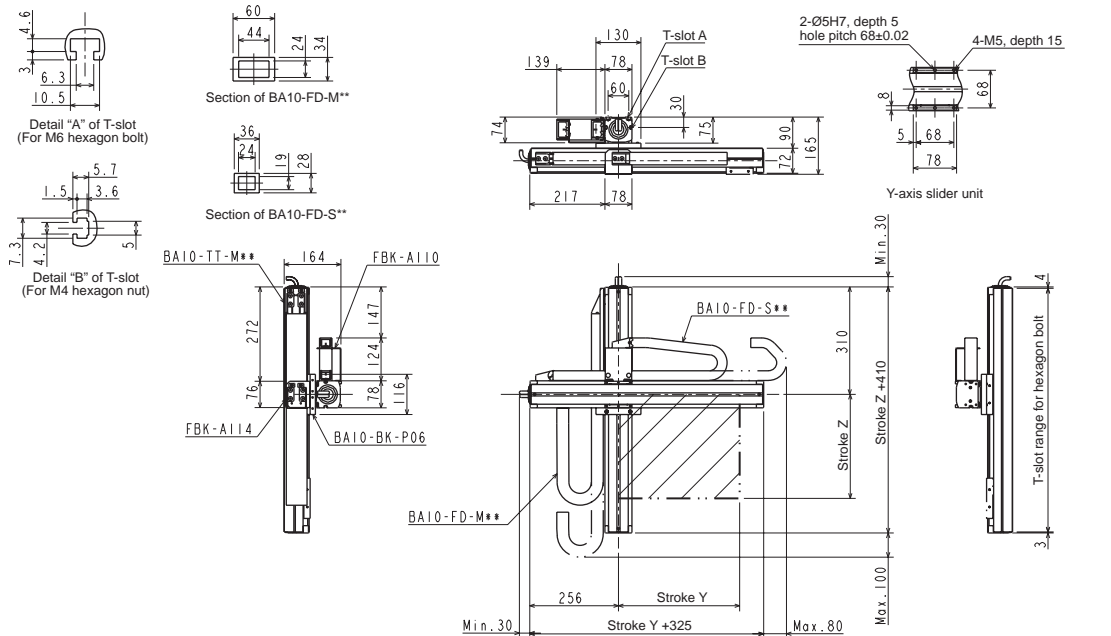

L: Left-handed

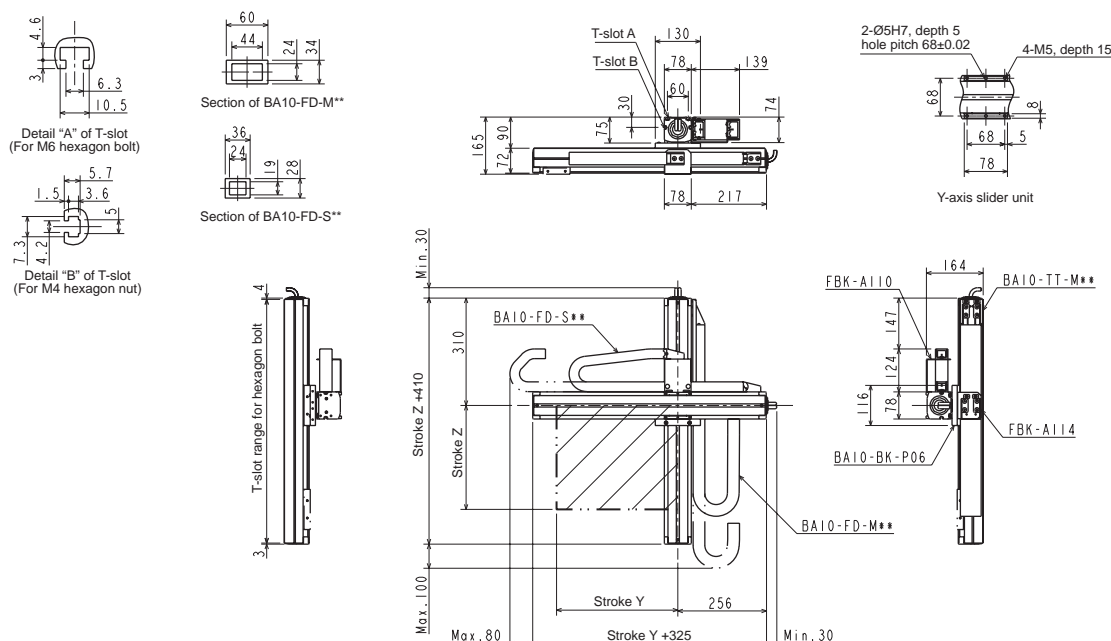

[Set designation]

BA3 - A3 - C2A RA - 45 40 00 - OF 1 3

Combined operation R: Right-handed L: Left-handed	Axis 1 stroke 15 : 150mm 95 : 950mm A5 : 1050mm	Axis 2 stroke 10 : 100mm 90 : 900mm	Controller (CA25-M10) 0 : None 1 : NPN output specifications Other : See page 20	Cable length 3 : 3m 9 : 9m 5 : 5m B : 11m 7 : 7m D : 13m
---	--	---	---	---

Ball screw type

Z-axis: Ball screw driven
Motor straight

Y-axis: Ball screw driven
Motor straight

Note 1: When the stroke is as given below, the maximum speed differs.

	Stroke (mm)	Maximum speed (mm/s)
Z-axis	750	250
	850	200
	950~1050	150
Y-axis	700	1000
	800	800
	900	600

[Specifications]

	Z-axis	Y-axis
Type of axis	BE30E-ST-M05B-□ 5	BE10E-ST-M20N-□ 0
Stroke (in increments of 100 mm)	150 ~ 1050mm	100 ~ 900mm
Maximum speed	300mm/s (Note 1)	1200mm/s (Note 1)
Positioning repeatability	± 0.01mm	
Lead of ball screw	5mm	20mm
Motor output	100W, with brake	100W
Resolution	0.01mm	

Acceleration/deceleration time when the maximum speed is set: 0.36 sec. or over

Maximum payload (kg) (Note 2)	Y-axis stroke								
	100mm	200mm	300mm	400mm	500mm	600mm	700mm	800mm	900mm
	15.0	15.0	14.0	12.0	9.0	7.0	5.0	3.0	1.0

Note 2: Payload when a regenerative discharge unit (ABSU-2000) is used.

R: Right-handed

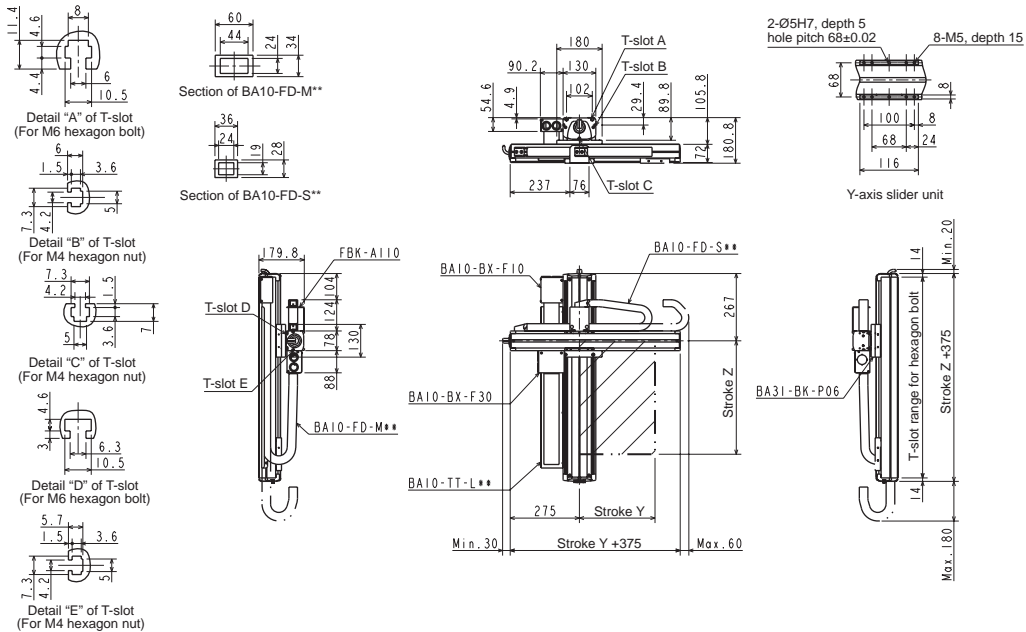

L: Left-handed

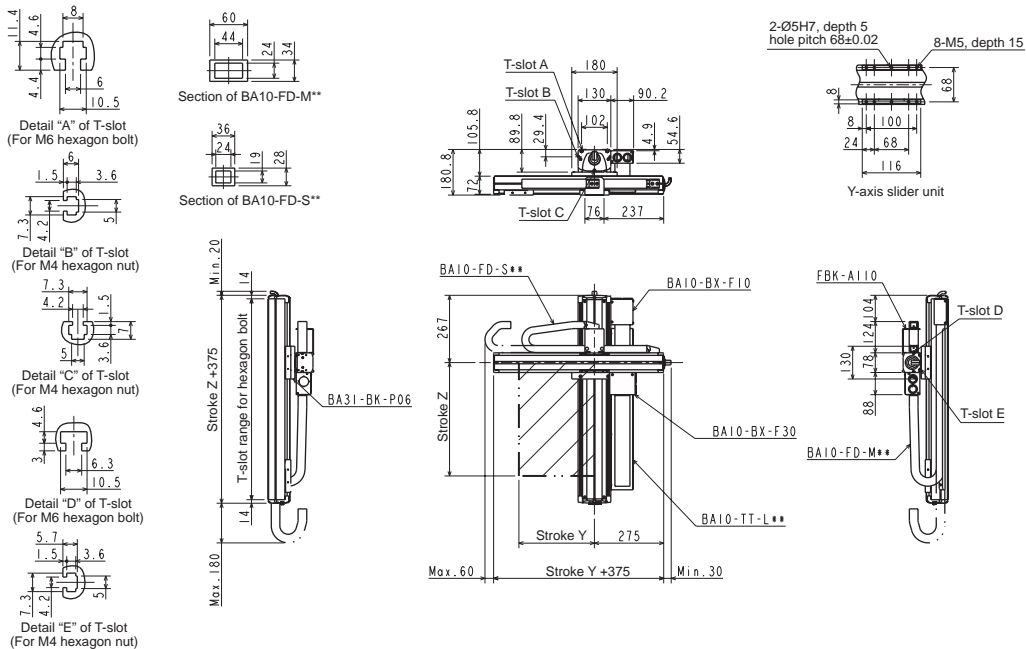

[Set designation]

BA3 - A3 - C2B RA - 40 40 00 - OF 1 3

Combined operation R: Right-handed L: Left-handed	Axis 1 stroke 10 : 100mm 90 : 900mm A0 : 1000mm	Axis 2 stroke 10 : 100mm 90 : 900mm	Controller (CA25-M10) 0 : None 1 : NPN output specifications Other : See page 20	Cable length 3 : 3m 9 : 9m 5 : 5m B : 11m 7 : 7m D : 13m
---	--	---	---	---

Ball screw type

Z-axis: Ball screw driven
Motor straight

Y-axis: Ball screw driven
Motor straight

Note 1: When the stroke is as given below, the maximum speed differs.

	Stroke (mm)	Maximum speed (mm/s)
Z-axis	700	250
	800	200
	900~1000	150
Y-axis	700	1000
	800	800
	900	600

[Specifications]

	Z-axis	Y-axis
Type of axis	BE30F-ST-M05B-□ 0	BE10E-ST-M20N-□ 0
Stroke (in increments of 100 mm)	100 ~ 1000mm	100 ~ 900mm
Maximum speed	300mm/s (Note 1)	1200mm/s (Note 1)
Positioning repeatability	±0.01mm	
Lead of ball screw	5mm	20mm
Motor output	200W, with brake	100W
Resolution	0.01mm	

Acceleration/deceleration time when the maximum speed is set: 0.36 sec. or over

Maximum payload (kg) (Note 2)	Y-axis stroke								
	100mm	200mm	300mm	400mm	500mm	600mm	700mm	800mm	900mm
	15.0	15.0	15.0	12.0	9.0	7.0	5.0	3.0	1.0

Note 2: Payload when a regenerative discharge unit (ABSU-2000) is used.

R: Right-handed

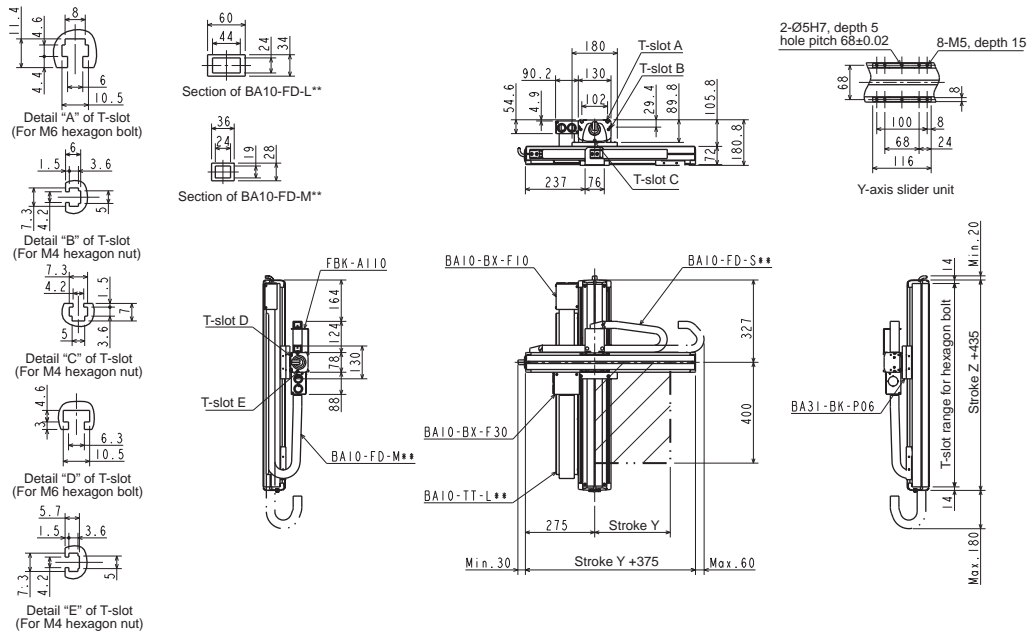

L: Left-handed

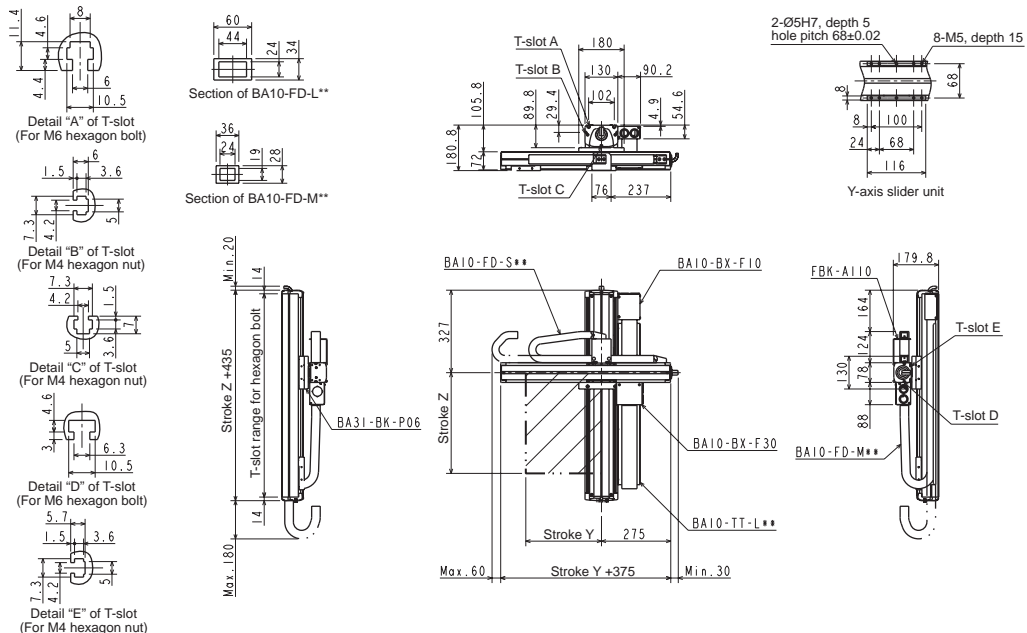

Z-Y flexible-duct Spec.

[Set designation]

BA3 – A5 – C2A RA – 40 45 00 – OF 1 3

Combined operation R: Right-handed L: Left-handed	Axis 1 stroke 20 : 200mm 90 : 900mm A0 : 1000mm G0 : 1600mm	Axis 2 stroke 15 : 150mm 95 : 950mm A5 : 1050mm	Controller (CA25-M10) 0 : None 1 : NPN output specifications Other : See page 20	Cable length 3 : 3m 9 : 9m 5 : 5m B : 11m 7 : 7m D : 13m
---	---	--	---	---

Ball screw type

Z-axis: Ball screw driven
Motor straight

Y-axis: Ball screw driven
Motor straight

Note 1: When the stroke is as given below, the maximum speed differs.

[Specifications]

	Z-axis	Y-axis
Type of axis	BE50F-ST-M05B-□ 0	BE30E-ST-M20N-□ 5
Stroke (in increments of 100 mm)	200 ~ 1600mm	150 ~ 1050mm
Maximum speed	300mm/s (Note 1)	1200mm/s (Note 1)
Positioning repeatability	±0.01mm	
Lead of ball screw	5mm	20mm
Motor output	200W, with brake	100W
Resolution	0.01mm	

Acceleration/deceleration time when the maximum speed is set: 0.36 sec. or over

	Stroke (mm)	Maximum speed (mm/s)
Z-axis	700~800	280
	900~1000	250
	1100~1200	180
	1300	130
	1400	100
	1500	80
Y-axis	1600	80
	750	1000
	850	800
	950~1050	600

Maximum payload (kg) (Note 2)	Y-axis stroke									
	150mm	250mm	350mm	450mm	550mm	650mm	750mm	850mm	950mm	1050mm
	20.0	20.0	20.0	20.0	20.0	20.0	18.0	14.0	11.0	7.0

Note 2: Payload when a regenerative discharge unit (ABSU-2000) is used.

R: Right-handed

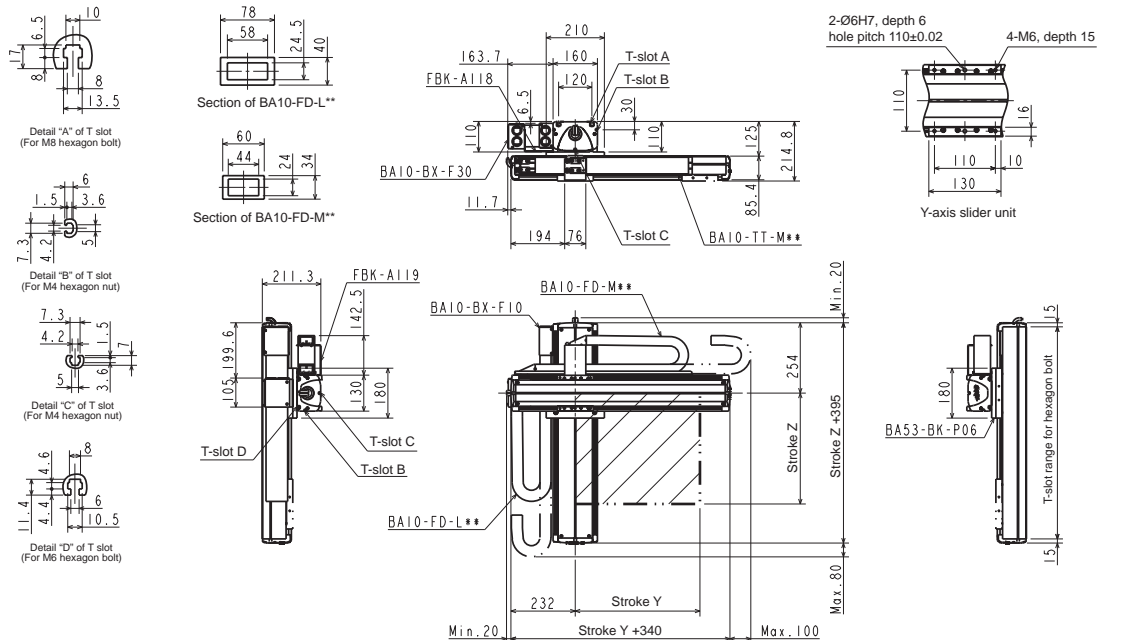

L: Left-handed

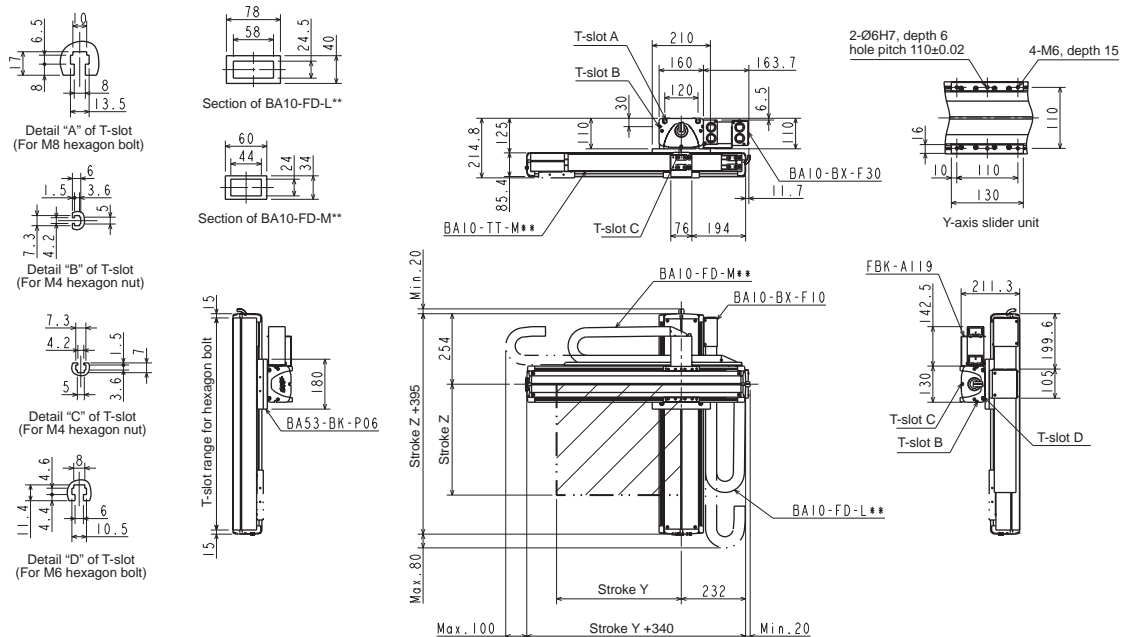

Z-Y flexible-duct Spec.

[Set designation]

BA3 – A5 – C2B RA – 40 40 00 – OF 1 3

Combined operation	Axis 1 stroke	Axis 2 stroke	Controller (CA25-M10)	Cable length	
R: Right-handed	20 : 200mm	10 : 100mm	0 : None	3 : 3m	9 : 9m
L: Left-handed	90 : 900mm	90 : 900mm	1 : NPN output specifications	5 : 5m	B : 11m
	A0 : 1000mm	A0 : 1000mm	Other : See page 20	7 : 7m	D : 13m
	G0 : 1600mm				

Ball screw type

Z-axis: Ball screw driven
Motor straight

Y-axis: Ball screw driven
Motor straight

Note 1: When the stroke is as given below, the maximum speed differs.

	Stroke (mm)	Maximum speed (mm/s)
Z-axis	700~800	280
	900~1000	250
	1100~1200	180
	1300	130
	1400	100
	1500	80
Y-axis	1600	80
	700	1000
	800	800
	900~1000	600

[Specifications]

	Z-axis	Y-axis
Type of axis	BE50F-ST-M05B-□ 0	BE30F-ST-M20N-□ 0
Stroke (in increments of 100 mm)	200 ~ 1600mm	100 ~ 1000mm
Maximum speed	300mm/s (Note 1)	1200mm/s (Note 1)
Positioning repeatability	±0.01mm	
Lead of ball screw	5mm	20mm
Motor output	200W, with brake	200W
Resolution	0.01mm	

Acceleration/deceleration time when the maximum speed is set: 0.36 sec. or over

Maximum payload (kg) (Note 2)	Y-axis stroke									
	100mm	200mm	300mm	400mm	500mm	600mm	700mm	800mm	900mm	1000mm
	28.0	27.0	26.0	24.0	23.0	22.0	18.0	14.0	11.0	7.0

Note 2: Payload when a regenerative discharge unit (ABSU-2000) is used.

R: Right-handed

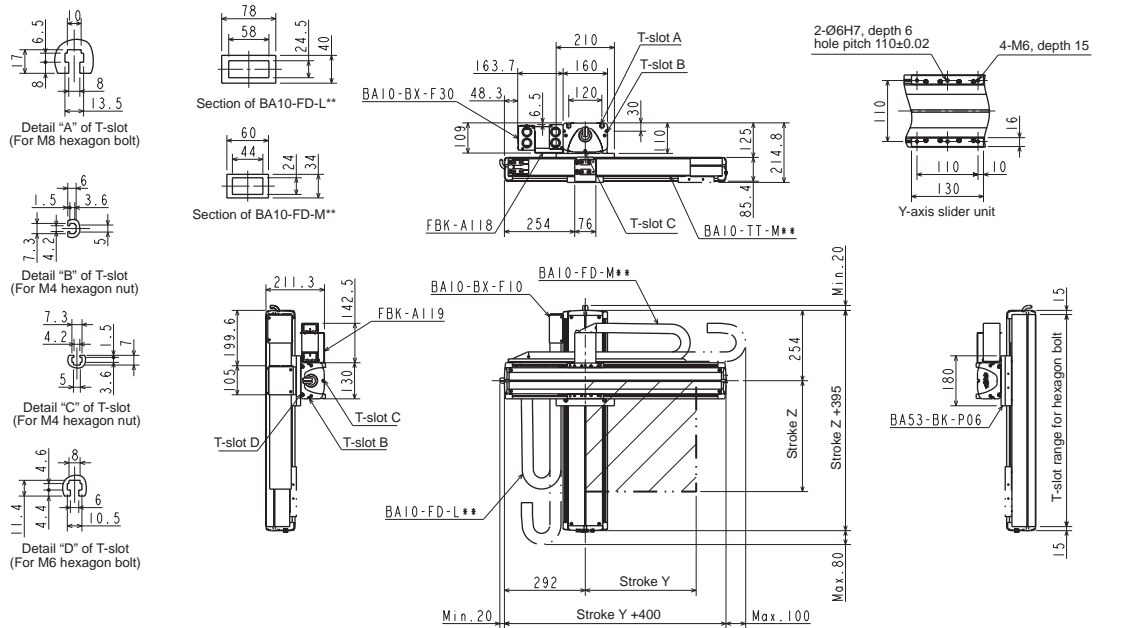

L: Left-handed

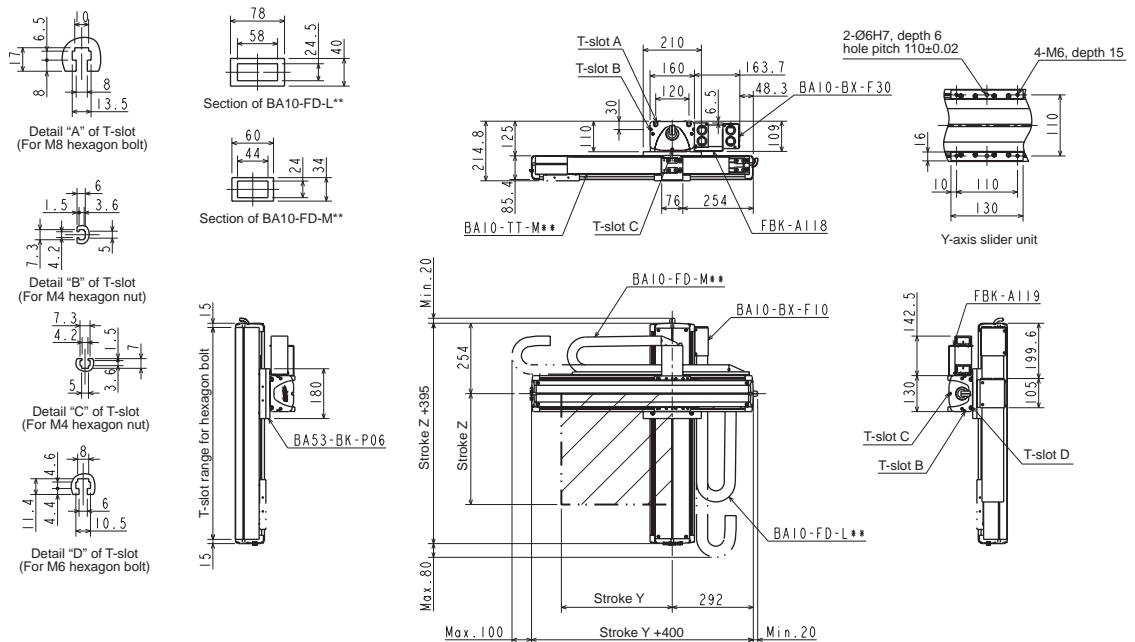

[Set designation]

BA3 - A1 - L2A R L - 40 45 00 - OF 1 3

Combined operation R: Right-handed L: Left-handed	Axis 1 stroke 10 : 100mm 15 : 150mm 90 : 900mm A0 : 1000mm	Axis 2 stroke 15 : 150mm 65 : 650mm	Controller (CA25-M10) 0 : None 1 : NPN output specifications Other : See page 20	Cable length 3 : 3m 9 : 9m 5 : 5m B : 11m 7 : 7m D : 13m
---	--	---	---	---

Timing belt type

Z-axis: Ball screw driven
Motor straight

Y-axis: Timing belt driven
Side mounted motor

[Specifications]

	Z-axis	Y-axis
Type of axis	BE10E-ST-M05B-□ 0	BE10E-B □ -S21N-□ 5
Stroke (in increments of 100 mm)	100 ~ 1000mm	150 ~ 650mm
Maximum speed	300mm/s (Note 1)	1000mm/s
Positioning repeatability	± 0.01 mm	± 0.04 mm
Lead	5 mm	21 mm (lead converted into ball screw)
Motor output	100W, with brake	100W
Resolution	0.01 mm	

Note 1: When the stroke is as given below, the maximum speed differs.

	Stroke (mm)	Maximum speed (mm/s)
Z-axis	700	250
	800	200
	900~1000	150

Acceleration/deceleration time when the maximum speed is set: 0.36 sec. or over

Maximum payload (kg) (Note 2)	Y-axis stroke					
	150mm	250mm	350mm	450mm	550mm	650mm
	15.0	12.0	9.0	6.0	5.0	3.0

Note 2: Payload when a regenerative discharge unit (ABSU-2000) is used.

R: Right-handed

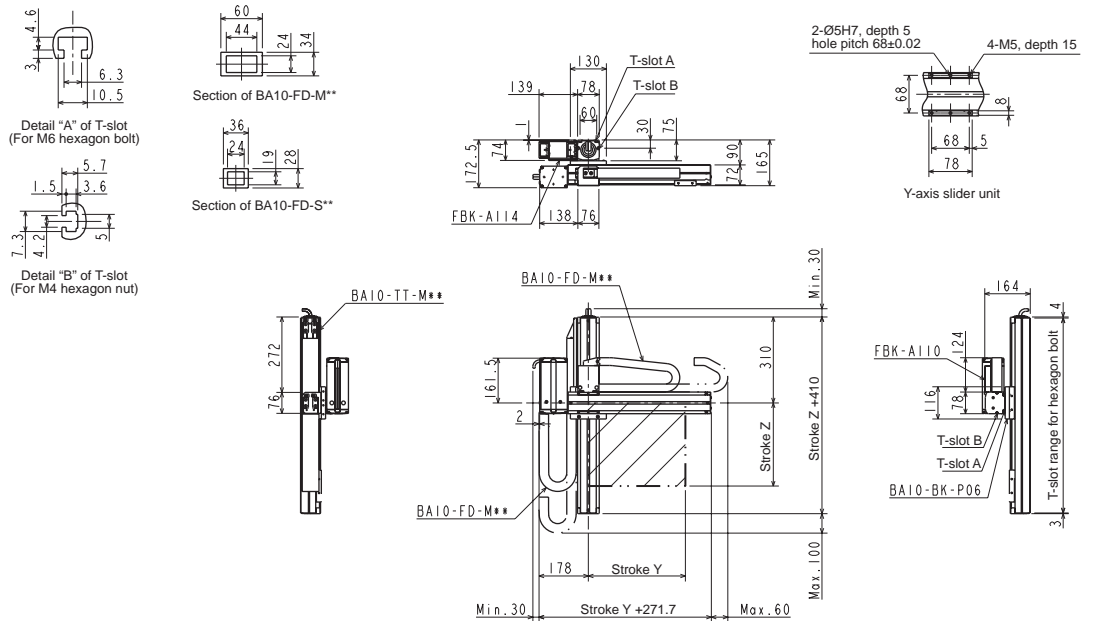

L: Left-handed

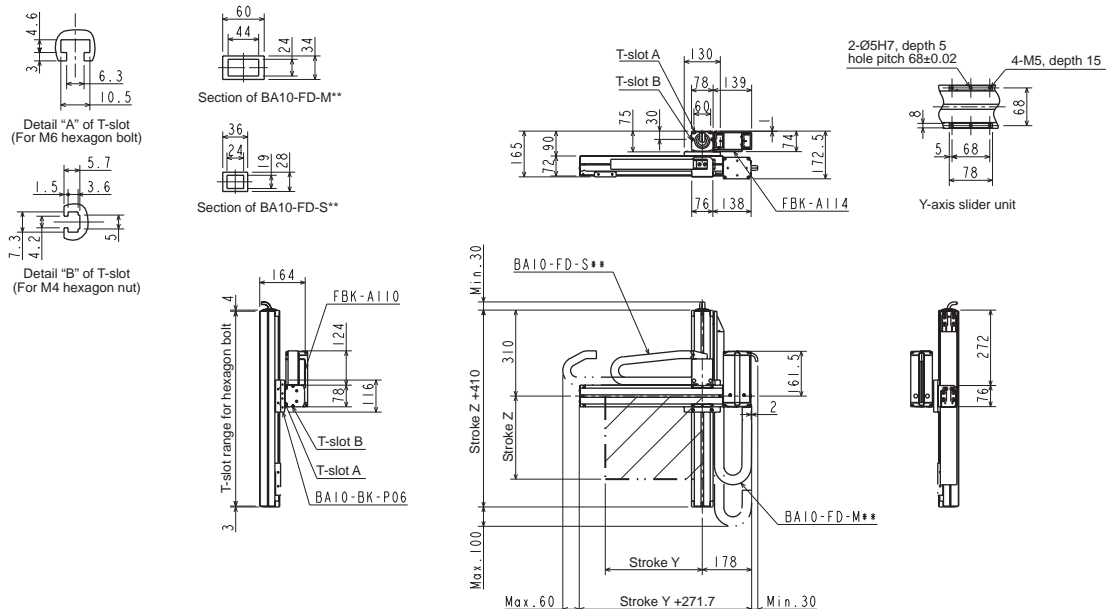

[Set designation]

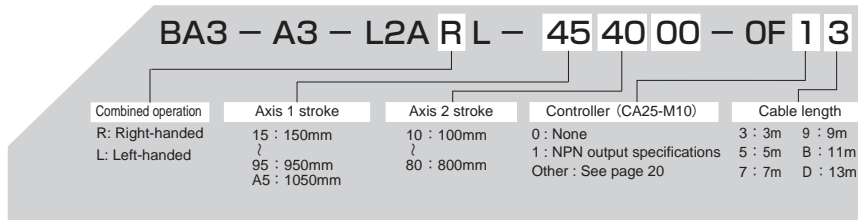

Timing belt type

- Z-axis: Ball screw driven
Motor straight
- Y-axis: Timing belt driven
Side mounted motor

[Specifications]

	Z-axis	Y-axis
Type of axis	BE30E-ST-M05B-□ 5	BE10E-B□ -M21N-□ 0
Stroke (in increments of 100 mm)	150 ~ 1050mm	100 ~ 800mm
Maximum speed	300mm/s (Note 1)	1000mm/s
Positioning repeatability	± 0.01 mm	± 0.04mm
Lead	5mm	21 mm (lead converted into ball screw)
Motor output	100W, with brake	100W
Resolution	0.01mm	

Note 1: When the stroke is as given below, the maximum speed differs.

	Stroke (mm)	Maximum speed (mm/s)
Z-axis	750	250
	850	200
	950~1050	150

Acceleration/deceleration time when the maximum speed is set: 0.36 sec. or over

Maximum payload (kg) (Note 2)	Y-axis stroke							
	100mm	200mm	300mm	400mm	500mm	600mm	700mm	800mm
	15.0	15.0	15.0	12.0	8.0	6.0	4.0	1.0

Note 2: Payload when a regenerative discharge unit (ABSU-2000) is used.

R: Right-handed

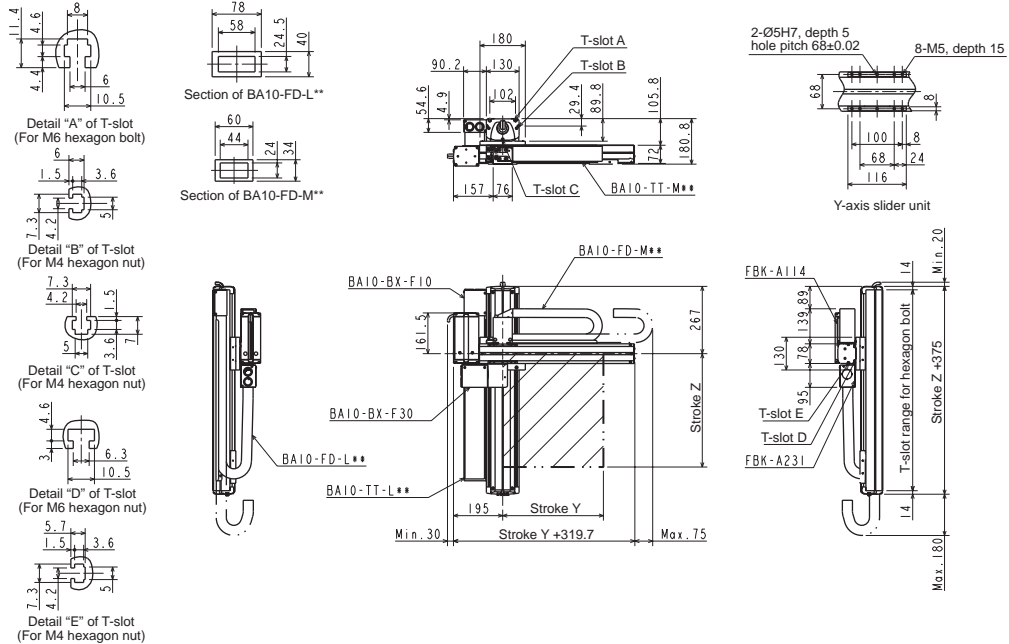

L: Left-handed

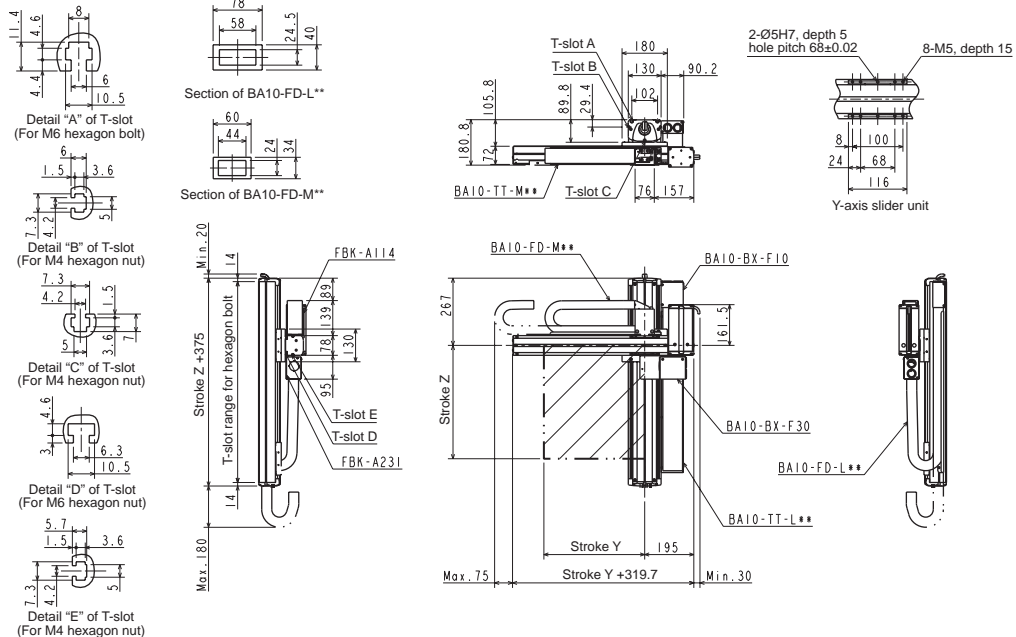

[Set designation]

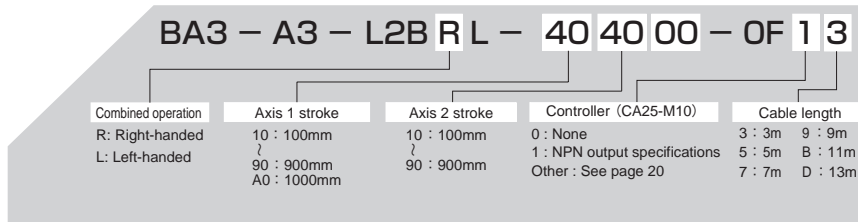

Timing belt type

Z-axis: Ball screw driven
Motor straight

Y-axis: Timing belt driven
Side mounted motor

[Specifications]

	Z-axis	Y-axis
Type of axis	BE30F-ST-M05B-□ 0	BE10E-B□ -M21N-□ 0
Stroke (in increments of 100 mm)	100 ~ 1000mm	100 ~ 900mm
Maximum speed	300mm/s (Note 1)	1000mm/s
Positioning repeatability	± 0.01 mm	± 0.04 mm
Lead	5 mm	21 mm (lead converted into ball screw)
Motor output	200W, with brake	100W
Resolution	0.01 mm	

Note 1: When the stroke is as given below, the maximum speed differs.

Z-axis	Stroke (mm)	Maximum speed (mm/s)
	700	250
	800	200
	900~1000	150

Acceleration/deceleration time when the maximum speed is set: 0.36 sec. or over

Maximum payload (kg) (Note 2)	Y-axis stroke								
	100mm	200mm	300mm	400mm	500mm	600mm	700mm	800mm	900mm
	15.0	15.0	15.0	12.0	9.0	7.0	5.0	3.0	1.0

Note 2: Payload when a regenerative discharge unit (ABSU-2000) is used.

R: Right-handed

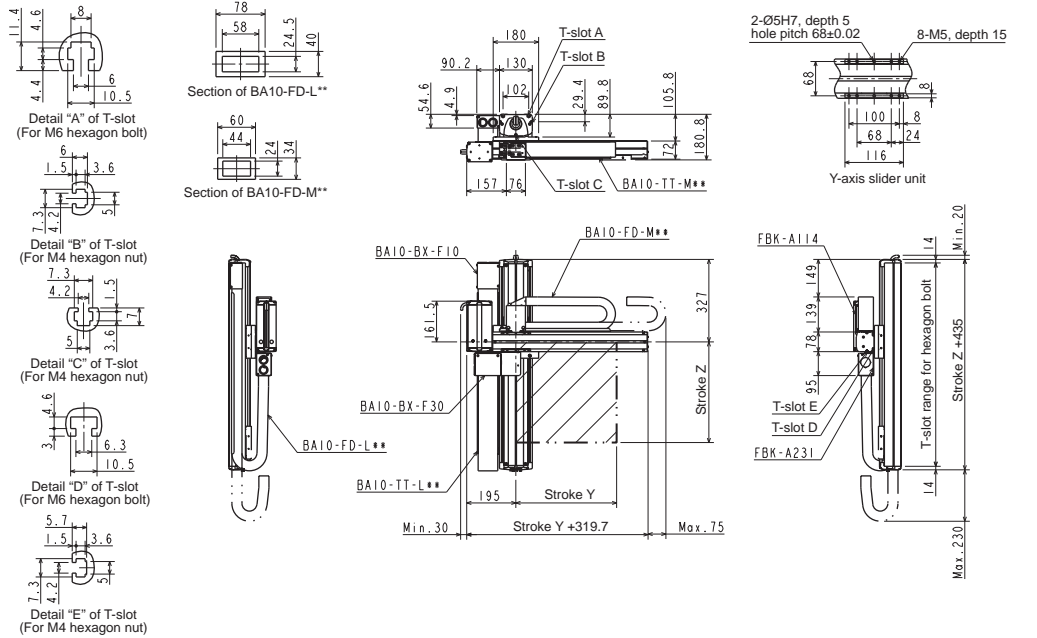

L: Left-handed

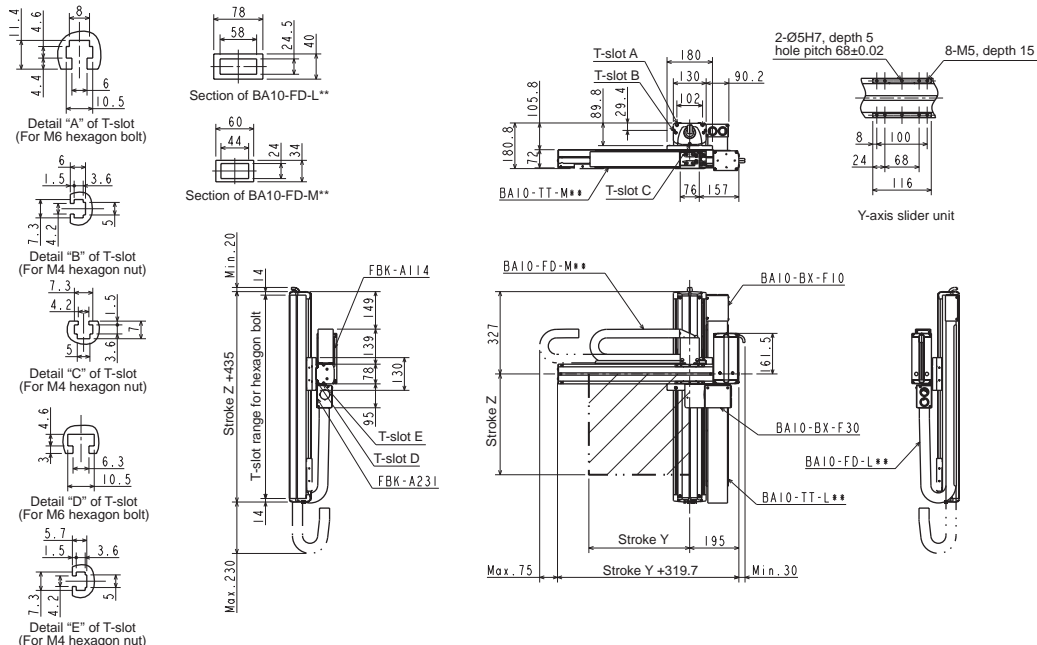

[Set designation]

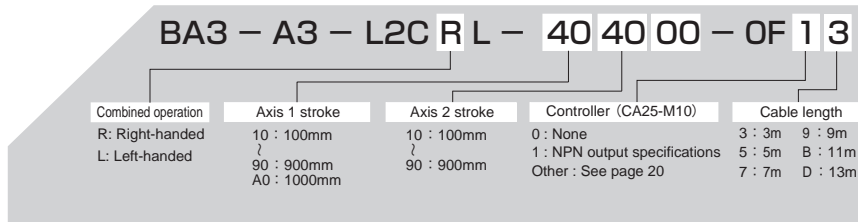

Timing belt type

- Z-axis: Ball screw driven
Motor straight
- Y-axis: Timing belt driven
Side mounted motor

[Specifications]

	Z-axis	Y-axis
Type of axis	BE30F-ST-M05B-□ 0	BE10F-B□ -M21N-□ 0
Stroke (in increments of 100 mm)	100 ~ 1000mm	100 ~ 900mm
Maximum speed	300mm/s (Note 1)	1000mm/s
Positioning repeatability	± 0.01 mm	± 0.04mm
Lead	5mm	21 mm (lead converted into ball screw)
Motor output	200W, with brake	200W
Resolution	0.01mm	

Note 1: When the stroke is as given below, the maximum speed differs.

	Stroke (mm)	Maximum speed (mm/s)
Z-axis	700	250
	800	200
	900~1000	150

Acceleration/deceleration time when the maximum speed is set: 0.36 sec. or over

Maximum payload (kg) (Note 2)	Y-axis stroke								
	100mm	200mm	300mm	400mm	500mm	600mm	700mm	800mm	900mm
	20.0	19.0	15.0	12.0	9.0	7.0	5.0	3.0	1.0

Note 2: Payload when a regenerative discharge unit (ABSU-2000) is used.

R: Right-handed

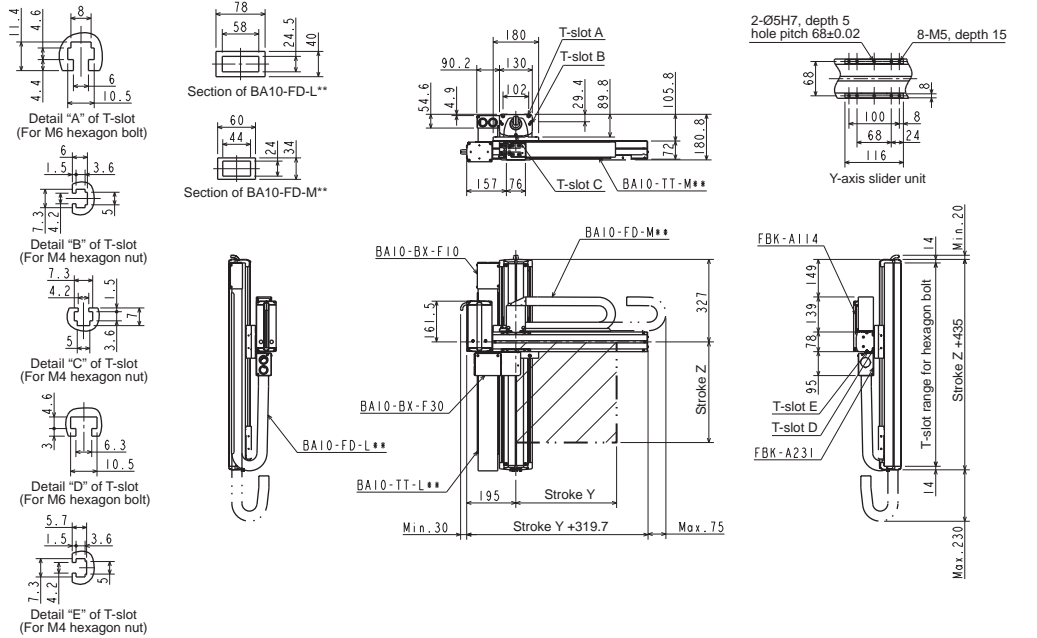

L: Left-handed

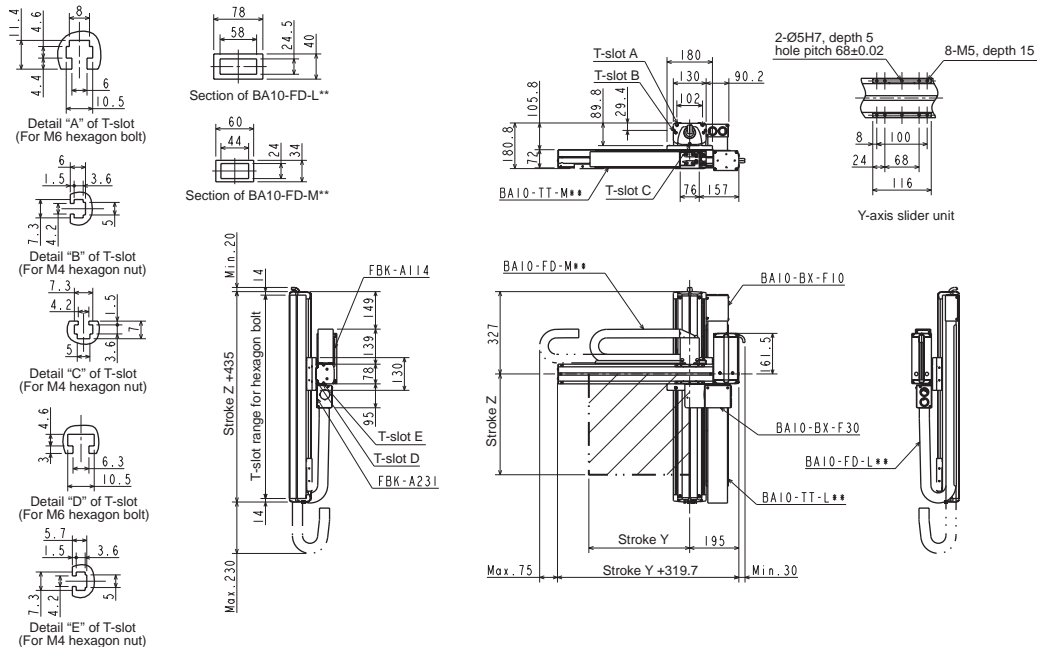

[Set designation]

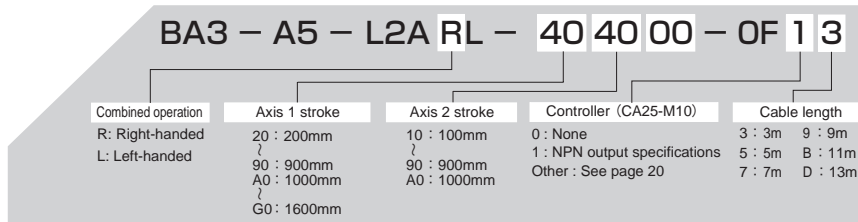

Timing belt type

Z-axis: Ball screw driven
Motor straight

Y-axis: Timing belt driven
Side mounted motor

Note 1: When the stroke is as given below, the maximum speed differs.

	Stroke (mm)	Maximum speed (mm/s)
Z-axis	700~800	280
	900~1000	250
	1100~1200	180
	1300	130
	1400	100
	1500	80
	1600	80

[Specifications]

	Z-axis	Y-axis
Type of axis	BE50F-ST-M05B-□ 0	BE30E-B□ -M21N-□ 0
Stroke (in increments of 100 mm)	200 ~ 1600mm	100 ~ 1000mm
Maximum speed	300mm/s (Note 1)	1000mm/s
Positioning repeatability	± 0.01 mm	± 0.04 mm
Lead of ball screw	5 mm	21 mm (lead converted into ball screw)
Motor output	200W, with brake	100W
Resolution	0.01 mm	

Acceleration/deceleration time when the maximum speed is set: 0.36 sec. or over

Maximum payload (kg) (Note 2)	Y-axis stroke									
	100mm	200mm	300mm	400mm	500mm	600mm	700mm	800mm	900mm	1000mm
	15.0	15.0	15.0	15.0	15.0	15.0	15.0	14.0	11.0	7.0

Note 2: Payload when a regenerative discharge unit (ABSU-2000) is used.

R: Right-handed

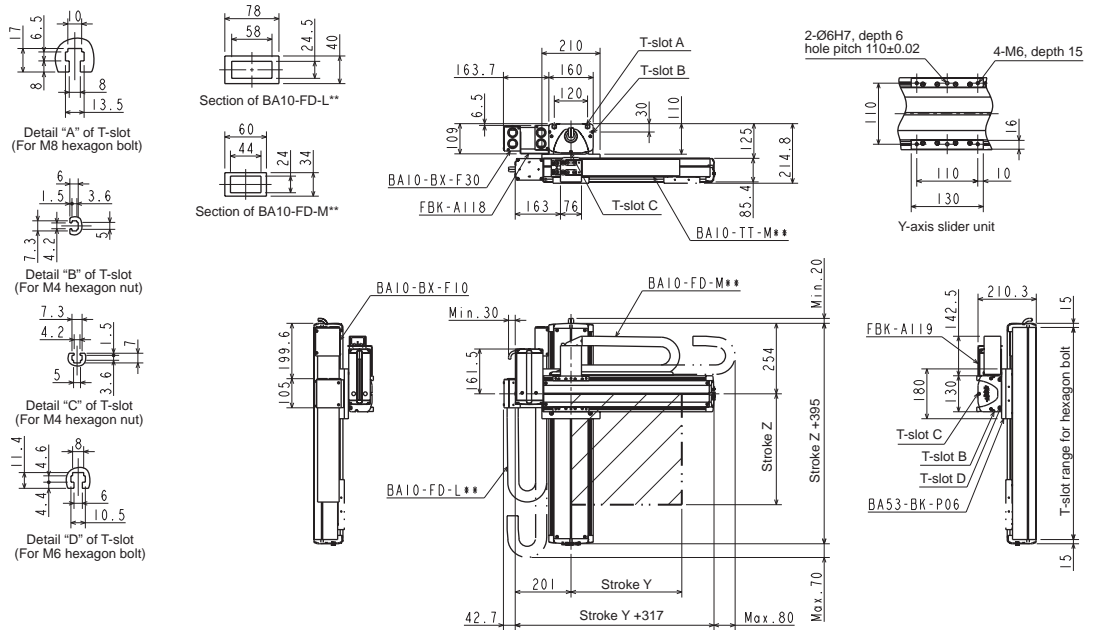

L: Left-handed

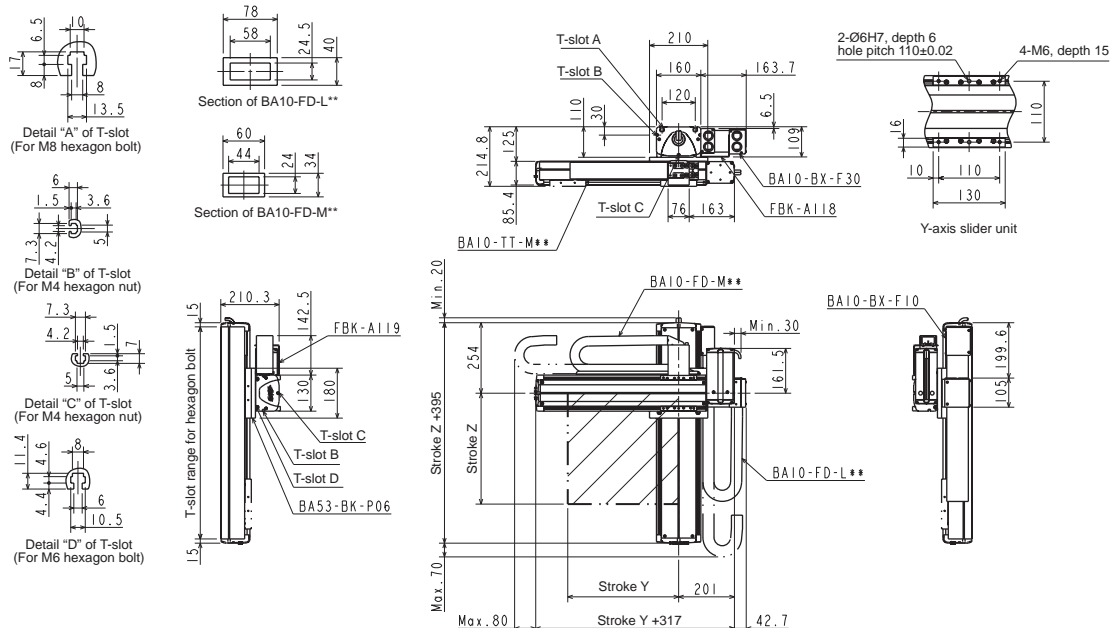

[Set designation]

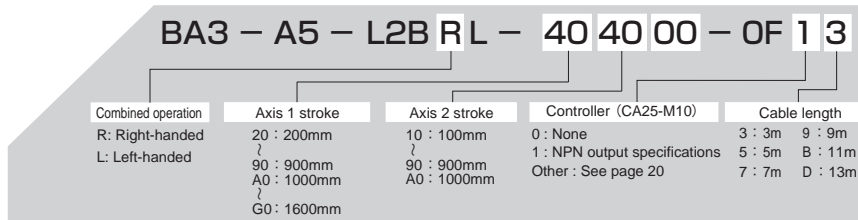

Timing belt type

Z-axis: Ball screw driven
Motor straight

Y-axis: Timing belt driven
Side mounted motor

Note 1: When the stroke is as given below, the maximum speed differs.

	Stroke (mm)	Maximum speed (mm/s)
Z-axis	700~800	280
	900~1000	250
	1100~1200	180
	1300	130
	1400	100
	1500	80
	1600	80

[Specifications]

	Z-axis	Y-axis
Type of axis	BE50F-ST-M05B-□ 0	BE30F-B□ -M21N-□ 0
Stroke (in increments of 100 mm)	200 ~ 1600mm	100 ~ 1000mm
Maximum speed	300mm/s (Note 1)	1000mm/s
Positioning repeatability	± 0.01 mm	± 0.04 mm
Lead	5 mm	21 mm (lead converted into ball screw)
Motor output	200W, with brake	200W
Resolution	0.01 mm	

Acceleration/deceleration time when the maximum speed is set: 0.36 sec. or over

Maximum payload (kg) (Note 2)	Y-axis stroke									
	100mm	200mm	300mm	400mm	500mm	600mm	700mm	800mm	900mm	1000mm
	27.0	26.0	25.0	24.0	23.0	22.0	18.0	14.0	11.0	7.0

Note 2: Payload when a regenerative discharge unit (ABSU-2000) is used.

R: Right-handed

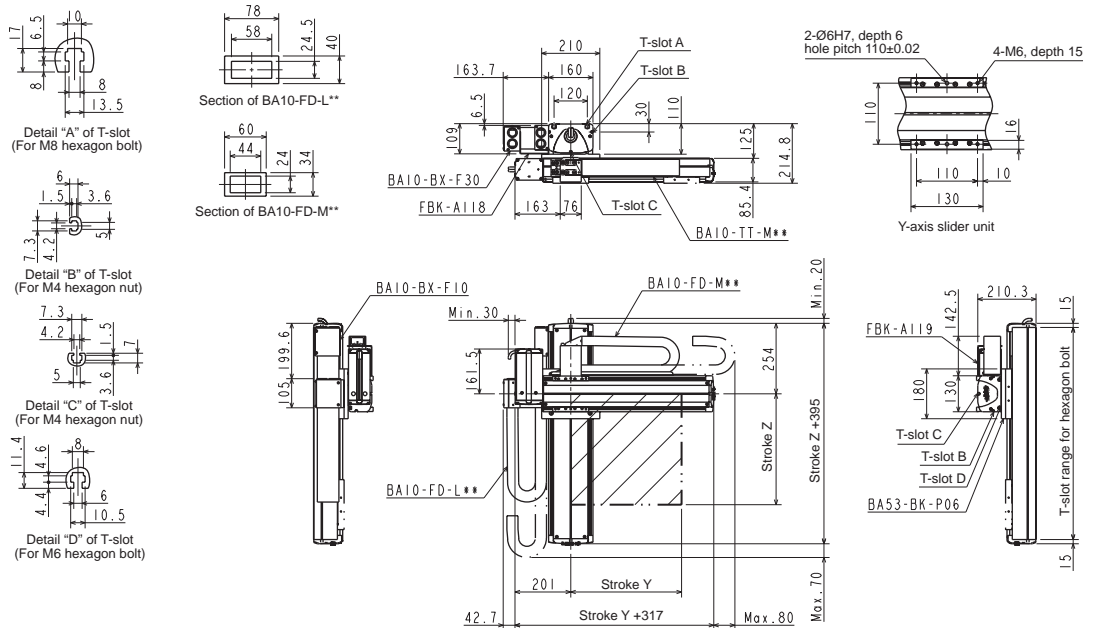

L: Left-handed

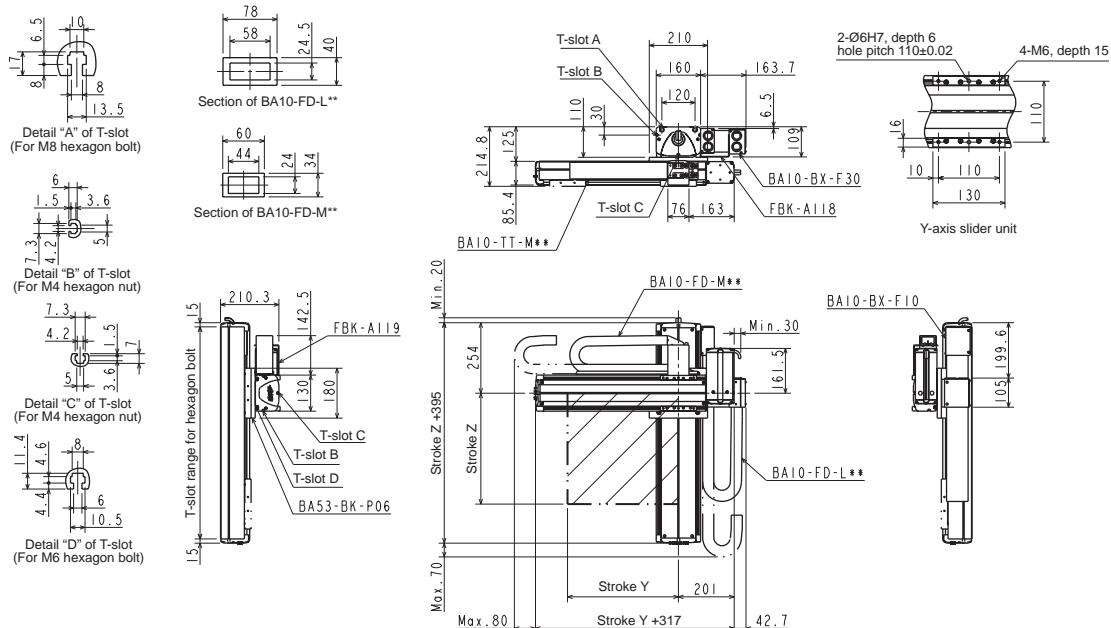

[Set designation]

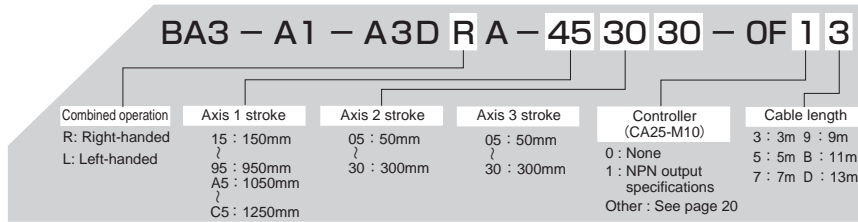

Ball screw type

- X-axis: Ball screw driven
Motor straight
- Y-axis: Ball screw driven
Motor straight
- Z-axis: Ball screw driven
Motor straight

[Specifications]

	X-axis	Y-axis	Z-axis
Type of axis	BE10E-ST-S20N-□5	BET7D-ST-M12N-□□	BET5D-ST-M06B-□□
Stroke (mm) (X-axis in increments of 100 mm, Y- and Z-axis in increments of 50mm)	150 ~ 1250	50 ~ 300	50 ~ 300
Maximum speed (mm/s)	1200 (Note 1)	800	400
Positioning repeatability (mm)	±0.01	±0.02	
Lead of ball screw (mm)	20	12	6
Motor output	100W	50W	50W, with brake
Resolution (mm)	0.01		

Note 1: When the stroke is as given below, the maximum speed differs.

X-axis	Stroke (mm)	Maximum speed (mm/s)
	750	1000
	850	800
	950~1050	600
	1150~1250	400

Acceleration/deceleration time when the maximum speed is set: 0.36 sec. or over

Maximum payload (kg)	Y-axis stroke					
	50mm	100mm	150mm	200mm	250mm	300mm
Z-axis stroke						
50,100mm	3.0	3.0	2.5	2.5	0.7	0.7
150,200mm	3.0	3.0	2.5	2.5	0.5	0.5
250,300mm	3.0	3.0	2.5	2.5	0.3	0.3

R: Right-handed

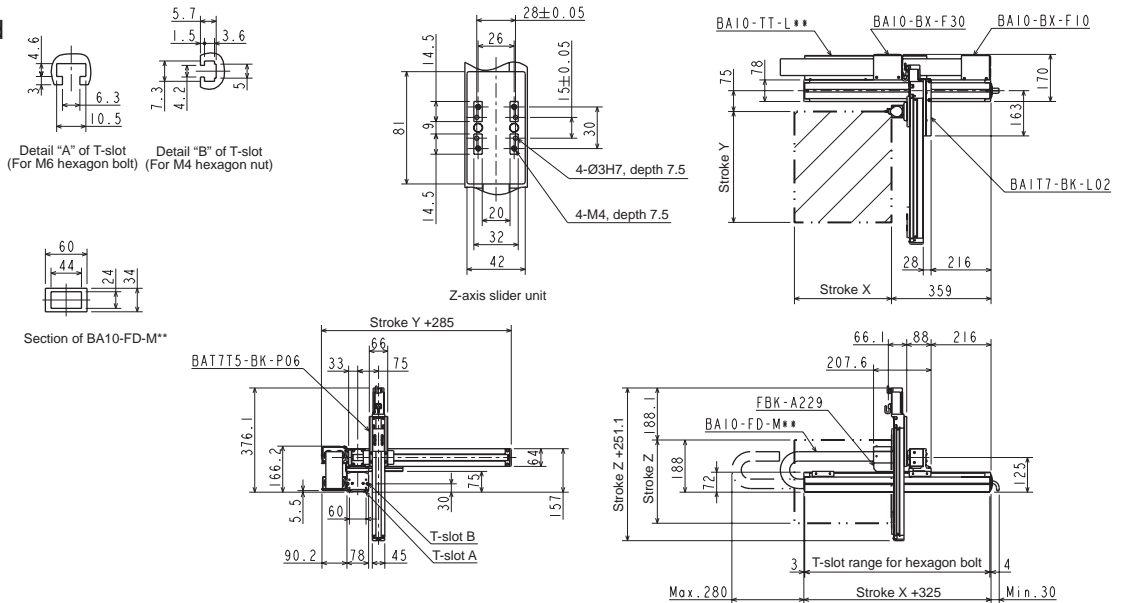

L: Left-handed

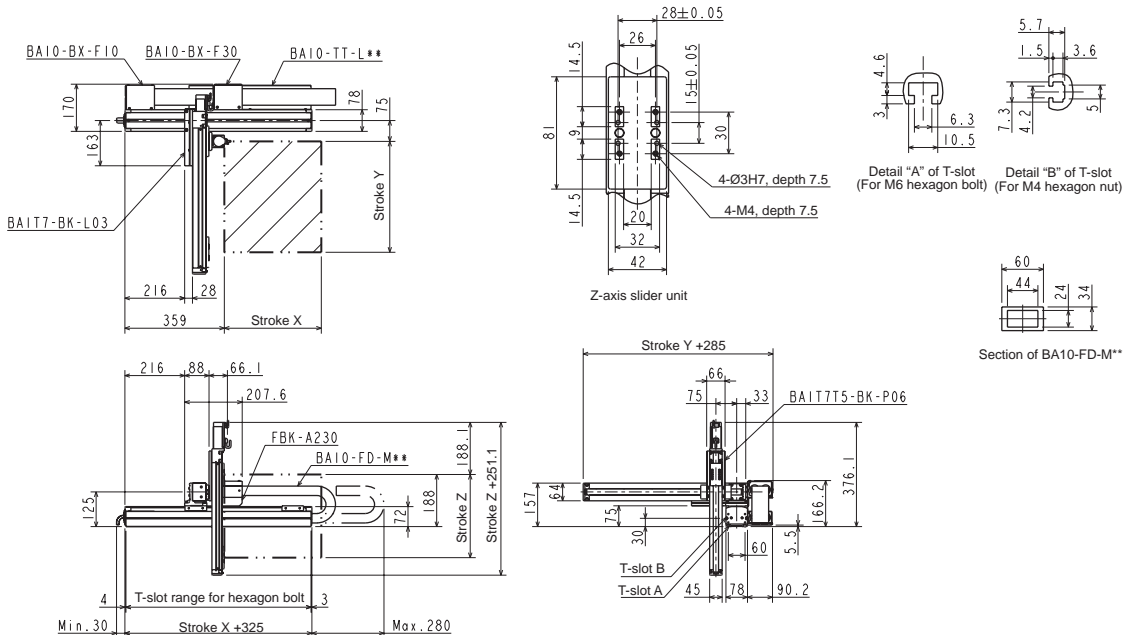

[Set designation]

BA3 - A1 - A3DRG - 45 30 30 - OF 1 3

Combined operation R: Right-handed L: Left-handed	Axis 1 stroke 15 : 150mm λ 95 : 950mm A5 : 1050mm C5 : 1250mm	Axis 2 stroke 05 : 50mm λ 30 : 300mm	Axis 3 stroke 05 : 50mm λ 30 : 300mm	Controller (CA25-M10) 0 : None 1 : NPN output specifications Other : See page 20	Cable length 3 : 3m 9 : 9m 5 : 5m B : 11m 7 : 7m D : 13m
---	--	---	---	---	---

Ball screw type

- X-axis: Ball screw driven
Side mounted motor
- Y-axis: Ball screw driven
Motor straight
- Z-axis: Ball screw driven
Motor straight

[Specifications]

	X-axis	Y-axis	Z-axis
Type of axis	BE10E-U □-S20N-□5	BET7D-ST-M12N-□□	BET5D-ST-M06B-□□
Stroke (mm) (X-axis in increments of 100 mm, Y- and Z-axis in increments of 50mm)	150 ~ 1250	50 ~ 300	50 ~ 300
Maximum speed (mm/s)	1200 (Note 1)	800	400
Positioning repeatability (mm)	± 0.01	± 0.02	
Lead of ball screw (mm)	20	12	6
Motor output	100W	50W	50W, with brake
Resolution (mm)	0.01		

Note 1: When the stroke is as given below, the maximum speed differs.

X-axis	Stroke (mm)	Maximum speed (mm/s)
	750	1000
	850	800
	950~1050	600
	1150~1250	400

Acceleration/deceleration time when the maximum speed is set: 0.36 sec. or over

Maximum payload (kg)	Y-axis stroke						
	50mm	100mm	150mm	200mm	250mm	300mm	
Z-axis stroke	50,100mm	3.0	3.0	2.5	2.5	0.7	0.7
	150,200mm	3.0	3.0	2.5	2.5	0.5	0.5
	250,300mm	3.0	3.0	2.5	2.5	0.3	0.3

R: Right-handed

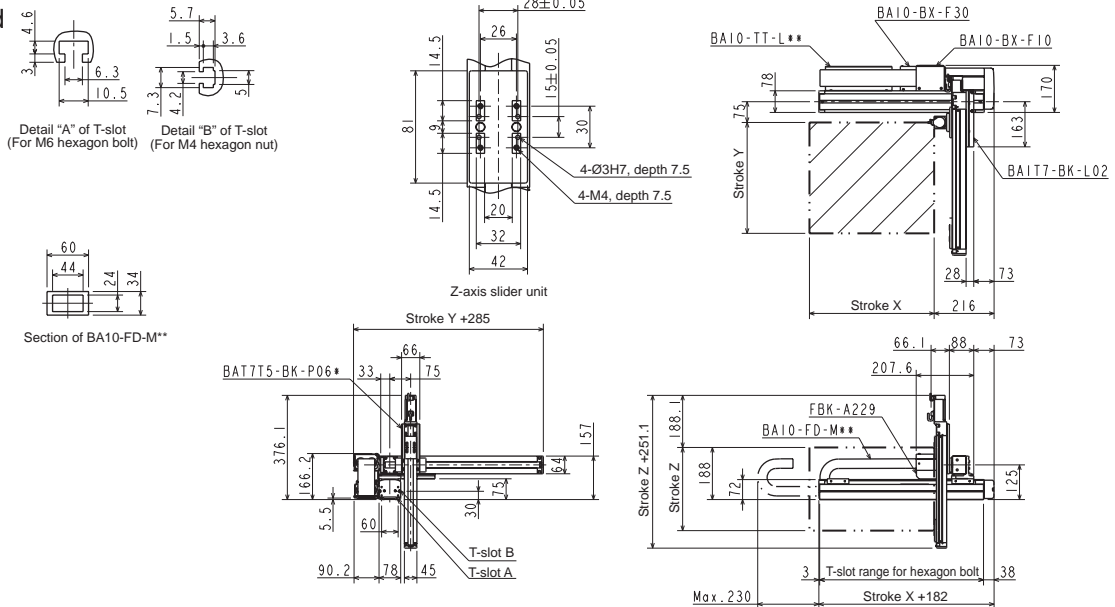

L: Left-handed

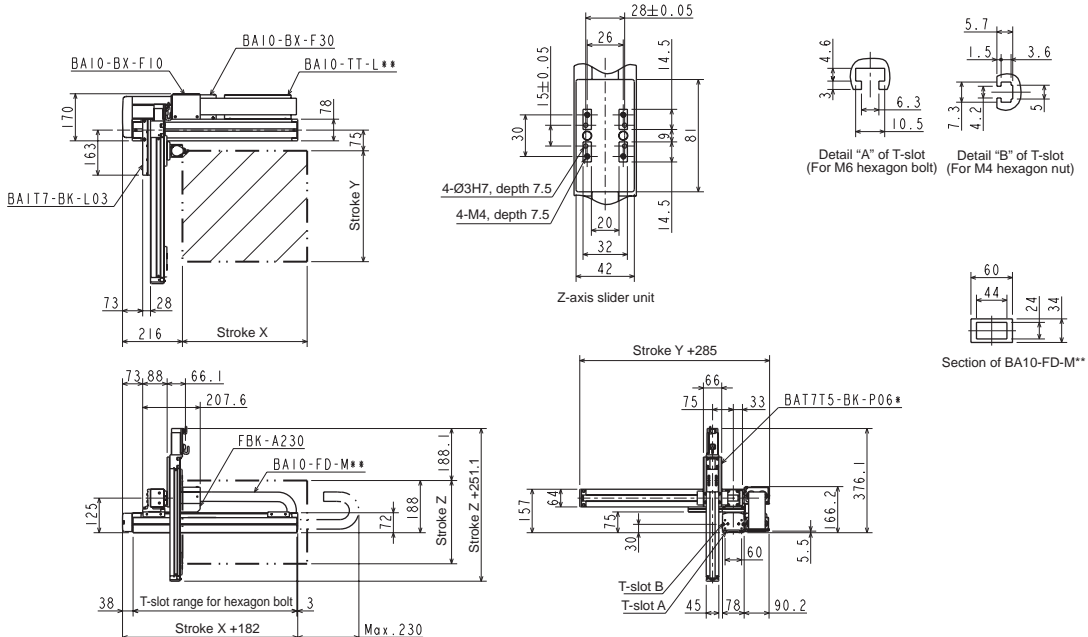

[Set designation]

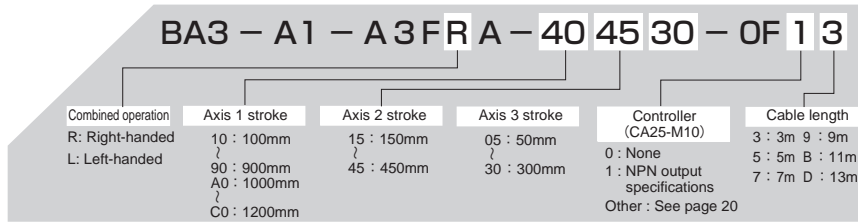

Ball screw type

- X-axis: Ball screw driven
Motor straight
- Y-axis: Ball screw driven
Motor straight
- Z-axis: Ball screw driven
Motor straight

[Specifications]

	X-axis	Y-axis	Z-axis
Type of axis	BE10E-ST-M20N-□0	BE10E-ST-S20N-□5	BET7D-ST-M06B-□□
Stroke (mm) (X- and Y-axis in increments of 100 mm, Z-axis in increments of 50mm)	100 ~ 1200	150 ~ 450	50 ~ 300
Maximum speed (mm/s)	1200 (Note 1)	1200	400
Positioning repeatability (mm)	± 0.01	± 0.01	± 0.02
Lead of ball screw (mm)	20	20	6
Motor output	100W	100W	50W, with brake
Resolution (mm)		0.01	

Note 1: When the stroke is as given below, the maximum speed differs.

X-axis	Stroke (mm)	Maximum speed (mm/s)
	700	1000
	800	800
	900~1000	600
	1100~1200	400

Acceleration/deceleration time when the maximum speed is set: 0.36 sec. or over

Maximum payload (kg)	Y-axis stroke			
	150mm	250mm	350mm	450mm
Z-axis stroke 50,100mm	4.0	3.5	2.5	1
150,200mm	4.0	2.5	2	0.6
250,300mm	3.5	2.5	1.5	0.2

R: Right-handed

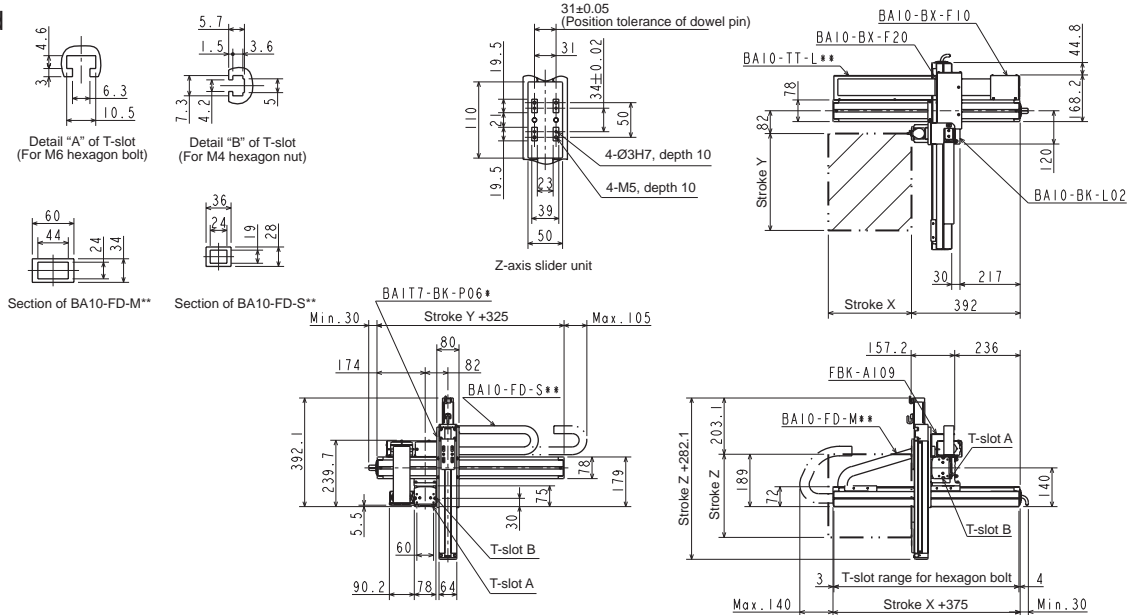

L: Left-handed

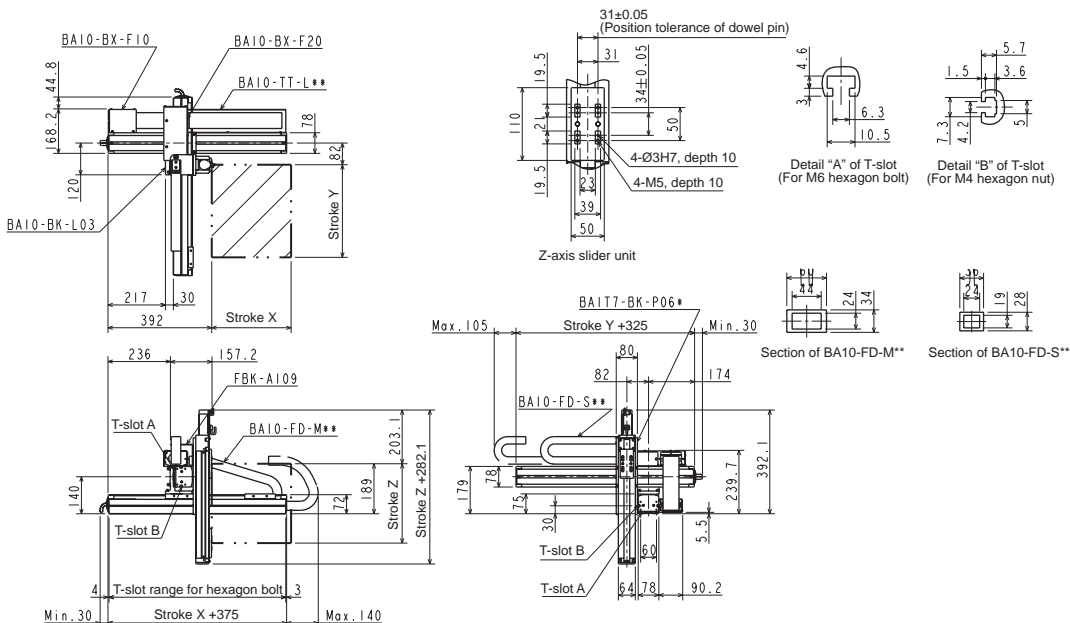

[Set designation]

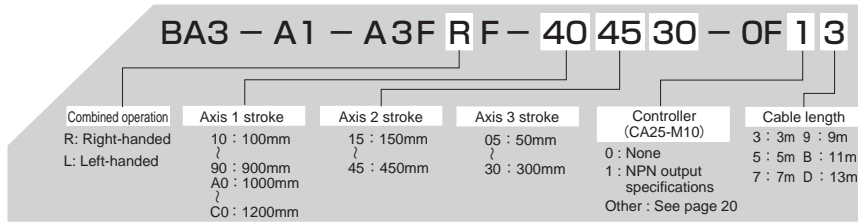

Ball screw type

- X-axis: Ball screw driven
Side mounted motor
- Y-axis: Ball screw driven
Side mounted motor
- Z-axis: Ball screw driven
Motor straight

[Specifications]

	X-axis	Y-axis	Z-axis
Type of axis	BE10E-U □-M20N- □0	BE10E-U □-S20N- □5	BET7D-ST-M06B- □□
Stroke (mm) (X- and Y-axis in increments of 100 mm, Z-axis in increments of 50mm)	100 ~ 1200	150 ~ 450	50 ~ 300
Maximum speed (mm/s)	1200 (Note 1)	1200 (Note 1)	400
Positioning repeatability (mm)	± 0.01	± 0.01	± 0.02
Lead of ball screw (mm)	20	20	6
Motor output	100W	100W	50W, with brake
Resolution (mm)	0.01		

Note 1: When the stroke is as given below, the maximum speed differs.

X-axis	Stroke (mm)	Maximum speed (mm/s)
	700	1000
800	800	
900~1000	600	
1100~1200	400	

Acceleration/deceleration time when the maximum speed is set: 0.36 sec. or over

Maximum payload (kg)	Y-axis stroke			
	150mm	250mm	350mm	300mm
Z-axis stroke 50,100mm	4.0	3.5	2.5	1
150,200mm	4.0	2.5	2	0.6
250,300mm	3.5	2.5	1.5	0.2

R: Right-handed

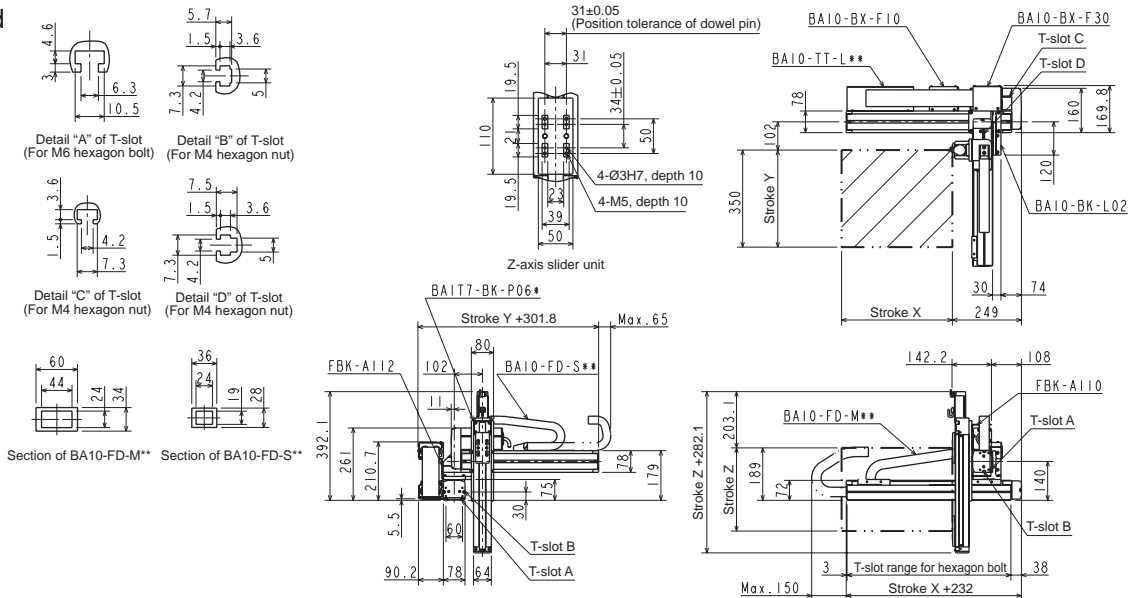

L: Left-handed

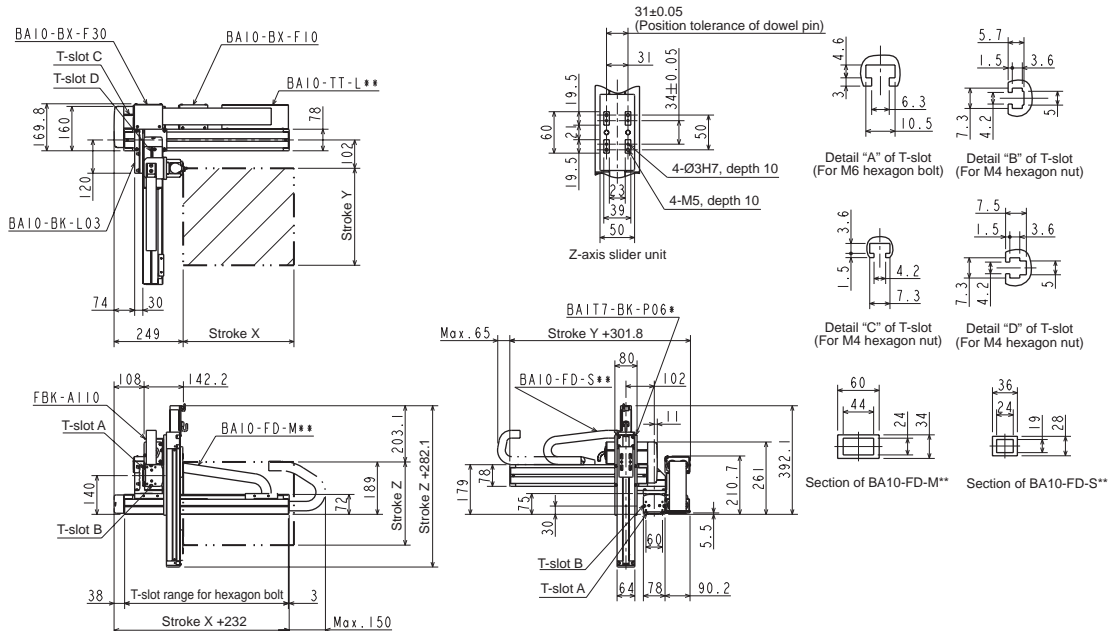

[Set designation]

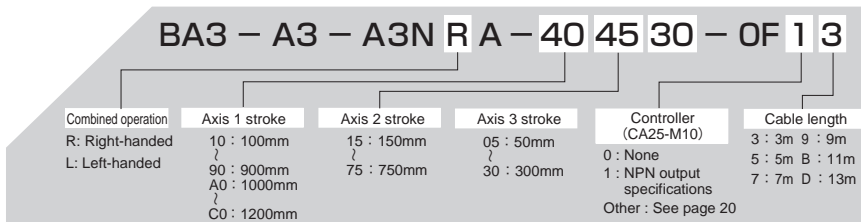

Ball screw type

- X-axis: Ball screw driven
Motor straight
- Y-axis: Ball screw driven
Motor straight
- Z-axis: Ball screw driven
Motor straight

[Specifications]

	X-axis	Y-axis	Z-axis
Type of axis	BE30F-ST-M20N-□0	BE10E-ST-S20N-□5	BET7D-ST-M06B-□□
Stroke (mm) (X- and Y-axis in increments of 100 mm, Z-axis in increments of 50mm)	100 ~ 1200	150 ~ 750	50 ~ 300
Maximum speed (mm/s)	1200 (Note 1)	1200 (Note 1)	400
Positioning repeatability (mm)	± 0.01	± 0.01	± 0.02
Lead of ball screw (mm)	20	20	6
Motor output	200W	100W	50W, with brake
Resolution (mm)	0.01		

Note 1: When the stroke is as given below, the maximum speed differs.

	Stroke (mm)	Maximum speed (mm/s)
X-axis	700	1000
	800	800
	900~1000	600
Y-axis	1100~1200	400
	750	1000

Acceleration/deceleration time when the maximum speed is set: 0.36 sec. or over

Maximum payload (kg)	Y-axis stroke						
	150mm	250 mm	350mm	450 mm	550mm	650mm	750mm
Z-axis stroke	50,100mm	4.0	4.0	4.0	4.0	3.9	1.6
	150,200mm	4.0	4.0	4.0	4.0	3.7	1.3
	250,300mm	4.0	4.0	4.0	4.0	3.5	1

R: Right-handed

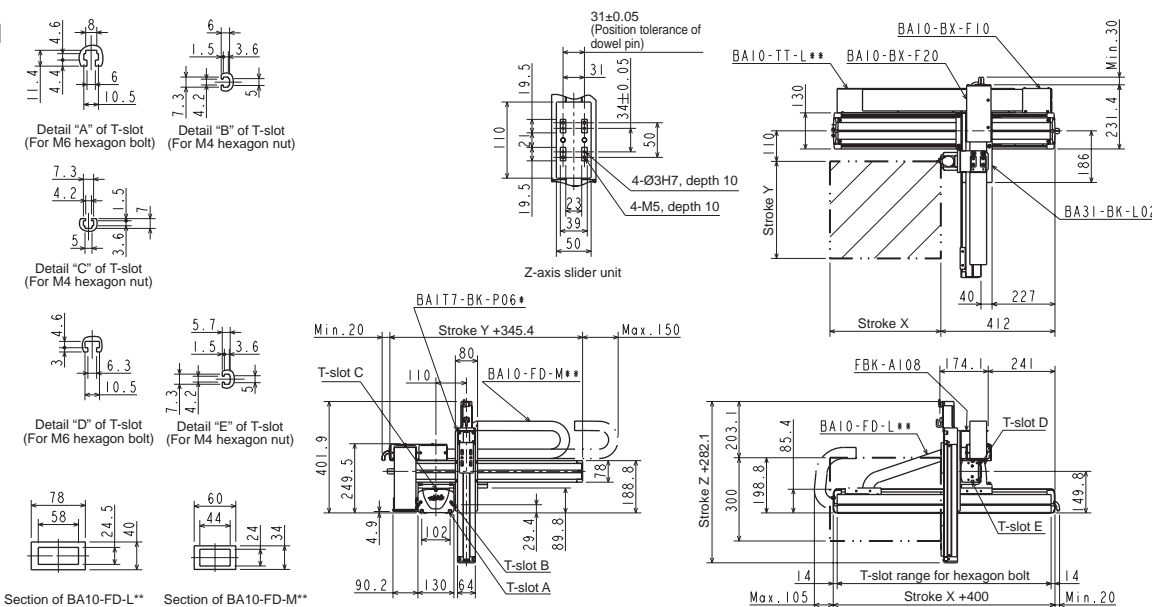

L: Left-handed

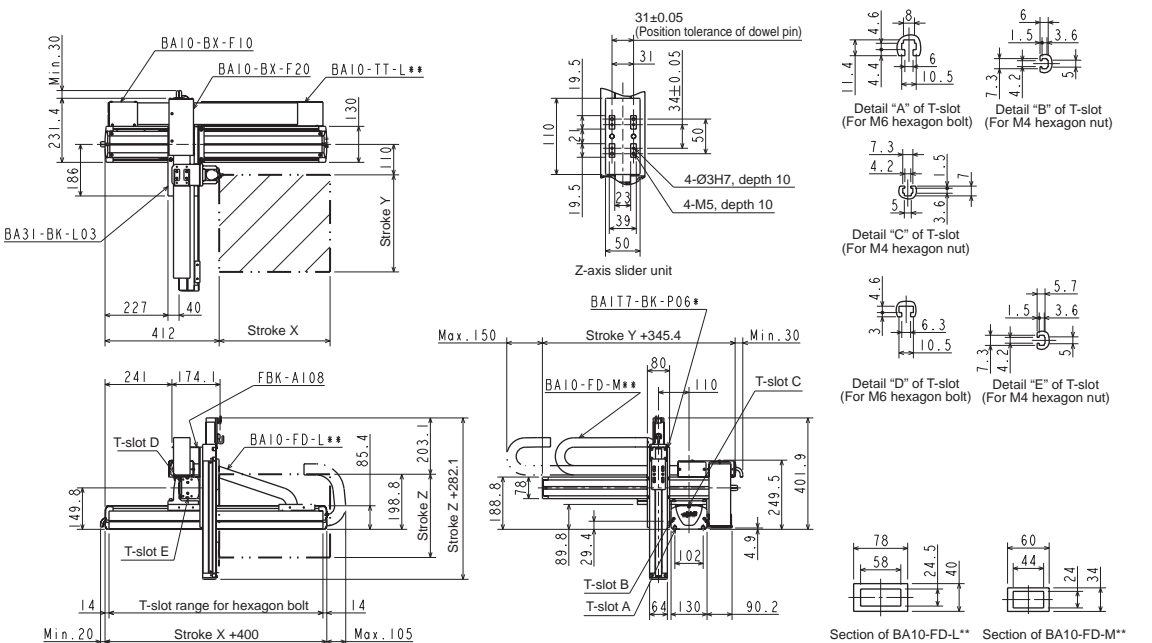

[Set designation]

BA3 - A3 - A3N R F - 40 45 30 - OF 1 3

Combined operation R: Right-handed L: Left-handed	Axis 1 stroke 10 : 100mm 90 : 900mm A0 : 1000mm C0 : 1200mm	Axis 2 stroke 15 : 150mm 75 : 750mm	Axis 3 stroke 05 : 50mm 30 : 300mm	Controller (CA25-M10) 0 : None 1 : NPN output specifications Other : See page 20	Cable length 3 : 3m 9 : 9m 5 : 5m B : 11m 7 : 7m D : 13m
---	---	---	--	---	---

Ball screw type

- X-axis: Ball screw driven
Side mounted motor
- Y-axis: Ball screw driven
Side mounted motor
- Z-axis: Ball screw driven
Motor straight

[Specifications]

	X-axis	Y-axis	Z-axis
Type of axis	BE30F-U □-M20N- □0	BE10E-U □-S20N- □5	BET7D-ST-M06B- □□
Stroke (mm) (X- and Y-axis in increments of 100 mm, Z-axis in increments of 50mm)	100 ~ 1200	150 ~ 750	50 ~ 300
Maximum speed (mm/s)	1200 (Note 1)	1200 (Note 1)	400
Positioning repeatability (mm)	± 0.01	± 0.01	± 0.02
Lead of ball screw (mm)	20	20	6
Motor output	200W	100W	50W, with brake
Resolution (mm)	0.01		

Note 1: When the stroke is as given below, the maximum speed differs.

	Stroke (mm)	Maximum speed (mm/s)
X-axis	700	1000
	800	800
	900~1000	600
	1100~1200	400
Y-axis	750	1000

Acceleration/deceleration time when the maximum speed is set: 0.36 sec. or over

Maximum payload (kg)	Y-axis stroke							
	150mm	250 mm	350mm	450 mm	550mm	650mm	750mm	
Z-axis stroke	50,100mm	4.0	4.0	4.0	4.0	3.9	3.4	1.6
	150,200mm	4.0	4.0	4.0	4.0	3.7	3.1	1.3
	250,300mm	4.0	4.0	4.0	4.0	3.5	2.8	1

R: Right-handed

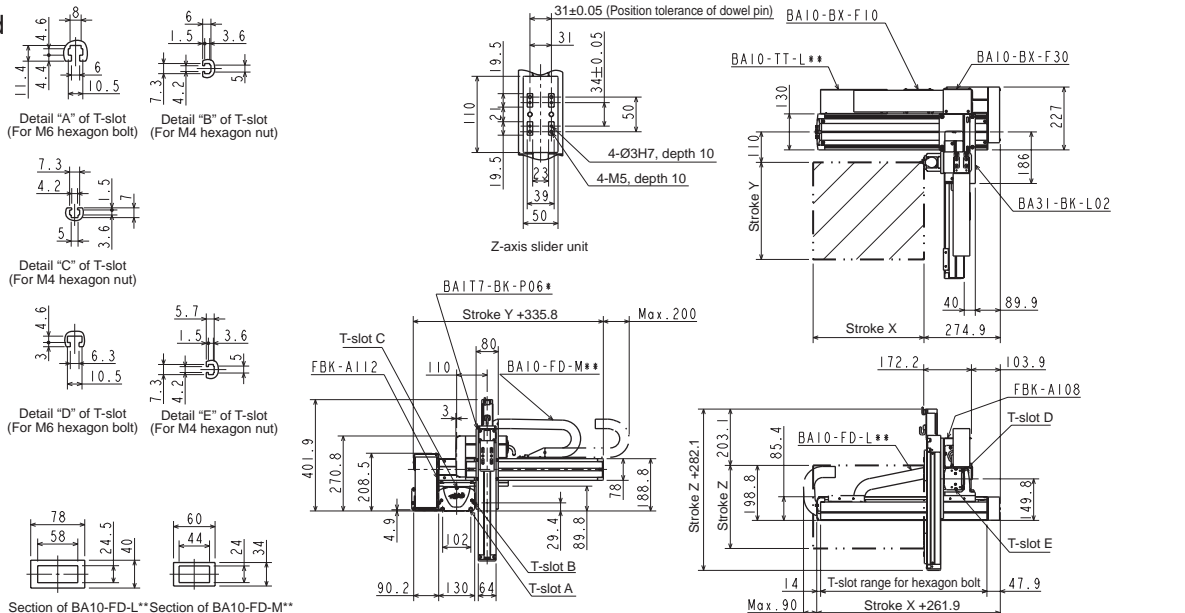

L: Left-handed

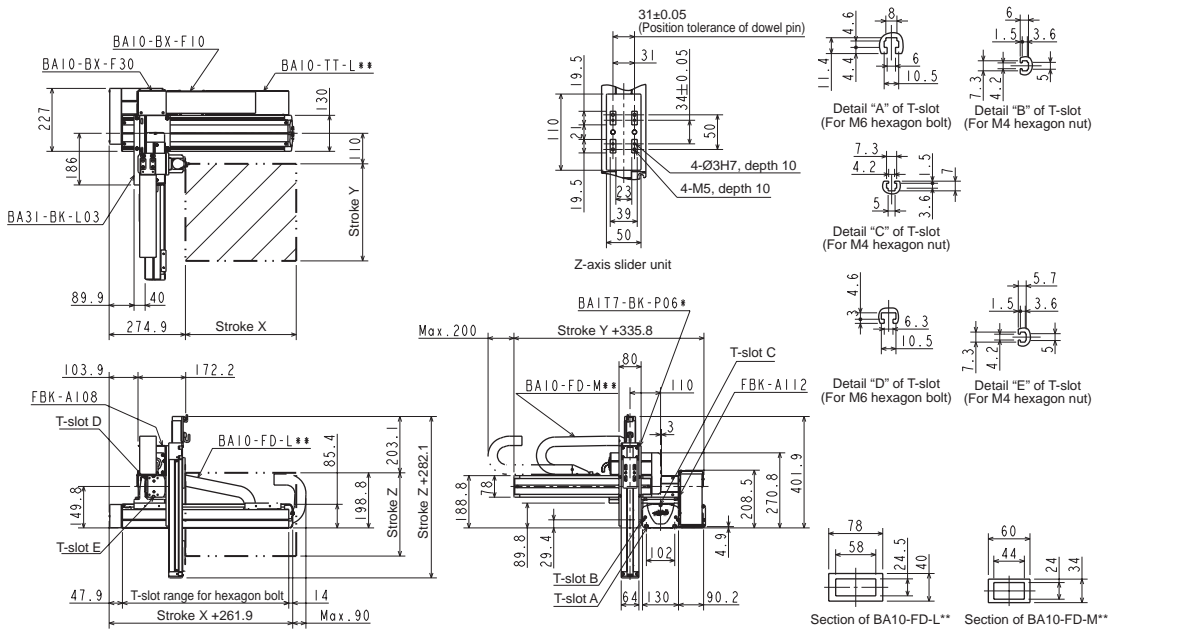

X-Y-Z Flexible-duct Spec.

[Set designation]

BA3 - A3 - A3AR B - 45 40 35 - OF 1 3

Combined operation	Axis 1 stroke	Axis 2 stroke	Axis 3 stroke	Controller (CA25-M10)	Cable length
R: Right-handed	15 : 150mm	10 : 100mm	15 : 150mm	0 : None	3 : 3m 9 : 9m
L: Left-handed	95 : 950mm A5 : 1050mm C5 : 1250mm	50 : 500mm	35 : 350mm	1 : NPN output specifications Other : See page 20	5 : 5m B : 11m 7 : 7m D : 13m

Ball screw type

- X-axis: Ball screw driven
Motor straight
- Y-axis: Ball screw driven
Motor straight
- Z-axis: Ball screw driven
Side mounted motor

[Specifications]

	X-axis	Y-axis	Z-axis
Type of axis	BE30E-ST-M20N-□5	BE10E-ST-M20N-□0	BE10E-U □-S10B-□5
Stroke (in increments of 100 mm)	150 ~ 1250mm	100 ~ 500mm	150 ~ 350mm
Maximum speed	1200mm/s (Note 1)	1200mm/s	600mm/s
Positioning repeatability	± 0.01 mm		
Lead of ball screw	20mm	20mm	10mm
Motor output	100W	100W	100W, with brake
Resolution	0.01 mm		

Note 1: When the stroke is as given below, the maximum speed differs.

	Stroke (mm)	Maximum speed (mm/s)
X-axis	750	1000
	850	800
	950~1050	600
	1150~1250	400

Acceleration/deceleration time when the maximum speed is set: 0.48 sec. or over

Maximum payload (kg)	Y-axis stroke					
	100mm	200mm	300mm	400mm	500mm	
Z-axis stroke	150mm	7.0	6.0	5.0	4.0	2.0
	250mm	6.0	5.0	4.0	4.0	2.0
	350mm	5.0	5.0	3.0	3.0	1.0

R: Right-handed

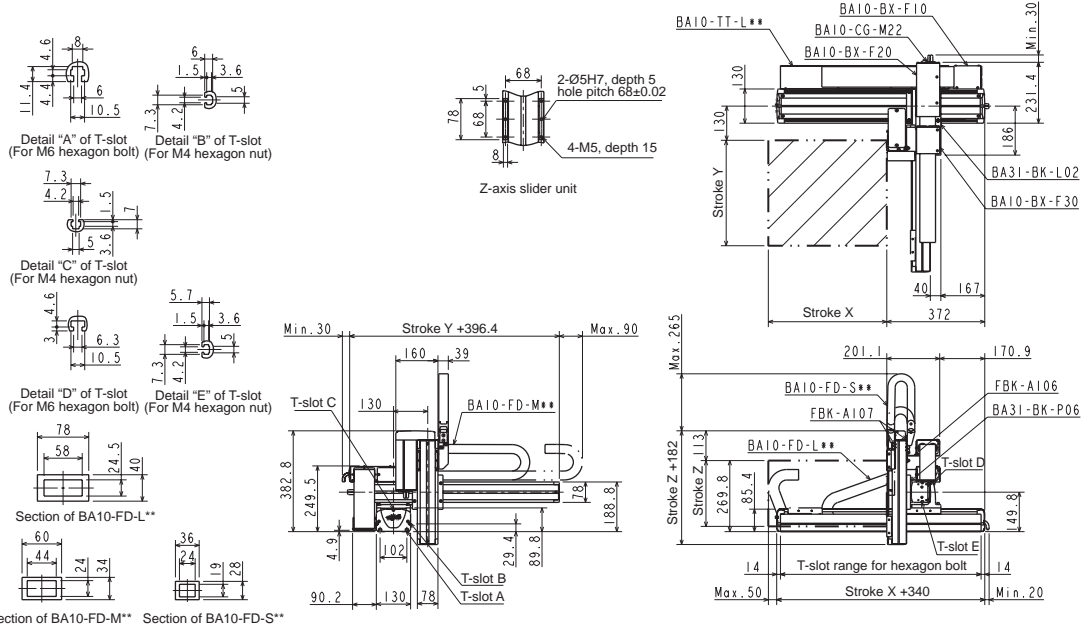

L: Left-handed

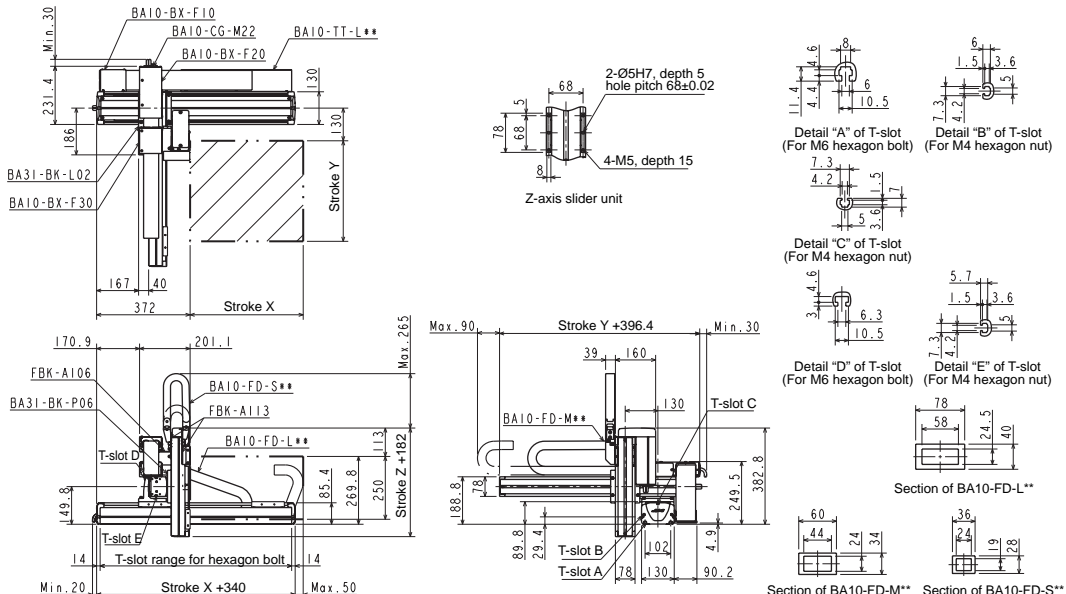

[Set designation]

BA3 - A3 - A3A RE - 40 40 35 - OF 1 3

Combined operation R: Right-handed L: Left-handed	Axis 1 stroke 10 : 100mm 90 : 900mm A0 : 1000mm C0 : 1200mm	Axis 2 stroke 10 : 100mm 50 : 500mm	Axis 3 stroke 15 : 150mm 35 : 350mm	Controller (CA25-M10) 0 : None 1 : NPN output specifications Other : See page 20	Cable length 3 : 3m 9 : 9m 5 : 5m B : 11m 7 : 7m D : 13m
---	---	---	---	---	---

Ball screw type

- X-axis: Ball screw driven
Side mounted motor
- Y-axis: Ball screw driven
Side mounted motor
- Z-axis: Ball screw driven
Side mounted motor

[Specifications]

	X-axis	Y-axis	Z-axis
Type of axis	BE30E-U □-M20N- □0	BE10E-U □-M20N- □0	BE10E-U □-S10B- □5
Stroke (in increments of 100 mm)	100 ~ 1200mm	100 ~ 500mm	150 ~ 350mm
Maximum speed	1200mm/s (Note 1)	1200mm/s	600mm/s
Positioning repeatability	± 0.01 mm		
Lead of ball screw	20mm	20mm	10mm
Motor output	100W	100W	100W, with brake
Resolution	0.01mm		

Note 1: When the stroke is as given below, the maximum speed differs.

	Stroke (mm)	Maximum speed (mm/s)
X-axis	700	1000
	800	800
	900~1000	600
	1100~1200	400

Acceleration/deceleration time when the maximum speed is set: 0.48 sec. or over

Maximum payload (kg)	Y-axis stroke					
	100mm	200mm	300mm	400mm	500mm	
Z-axis stroke	150mm	7.0	6.0	5.0	4.0	2.0
	250mm	6.0	5.0	4.0	4.0	2.0
	350mm	5.0	5.0	3.0	3.0	1.0

R: Right-handed

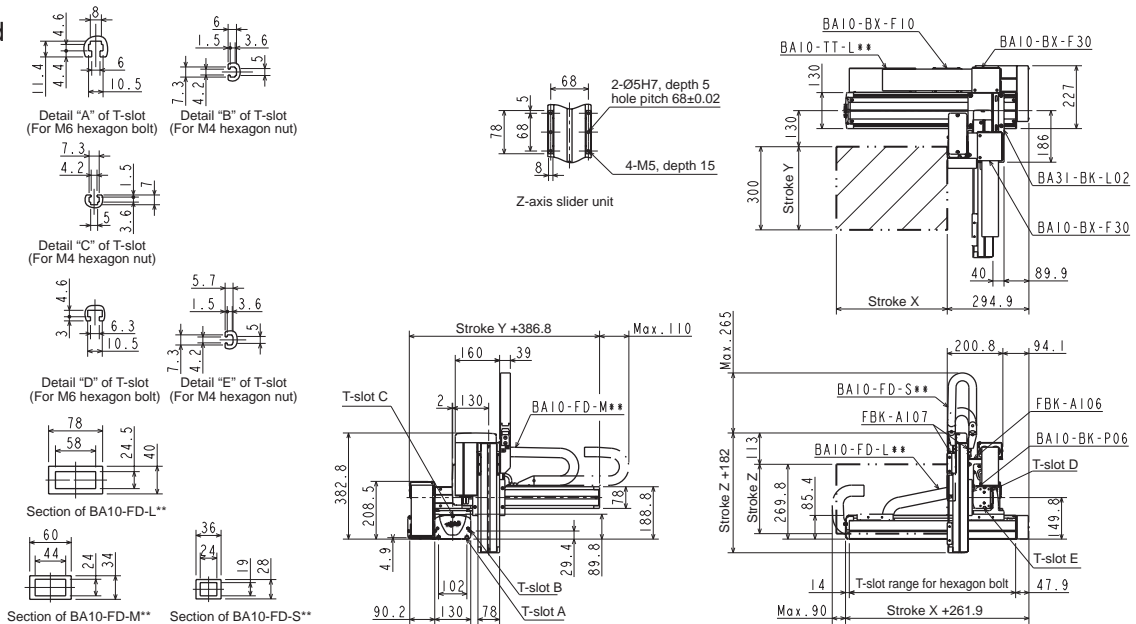

L: Left-handed

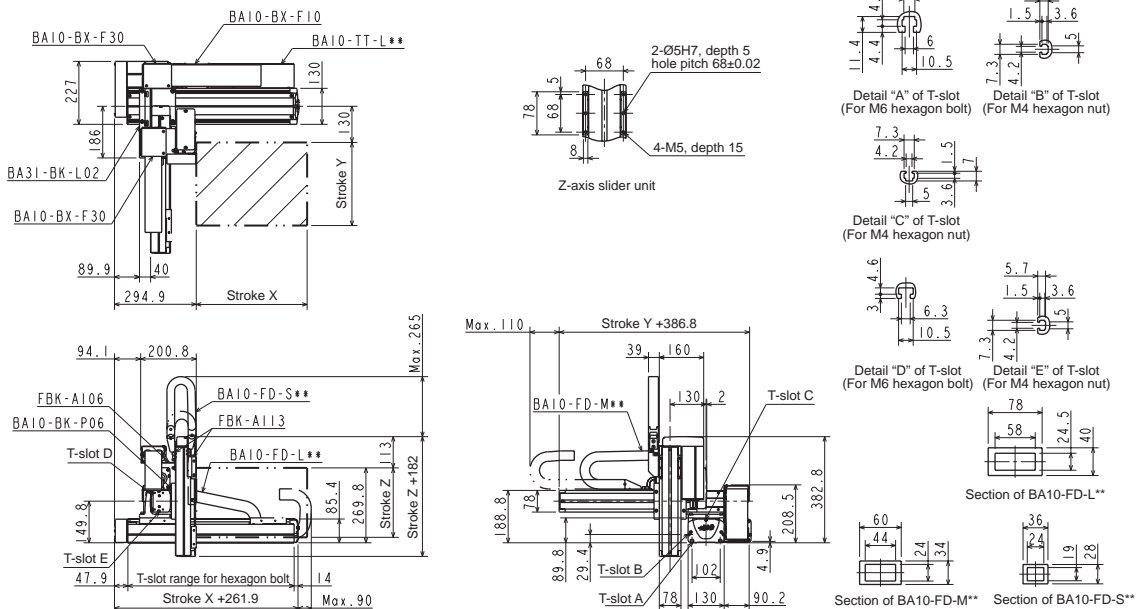

[Set designation]

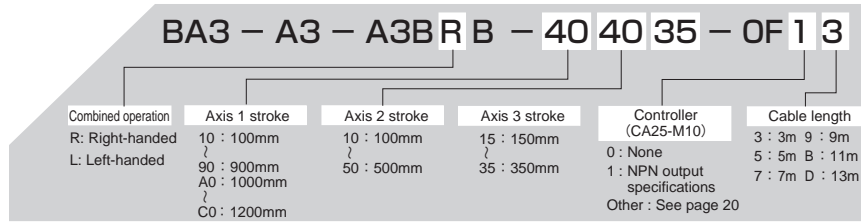

Ball screw type

- X-axis: Ball screw driven
Motor straight
- Y-axis: Ball screw driven
Motor straight
- Z-axis: Ball screw driven
Side mounted motor

[Specifications]

	X-axis	Y-axis	Z-axis
Type of axis	BE30F-ST-M20N-□0	BE10E-ST-M20N-□0	BE10E-U□-S10B-□5
Stroke (in increments of 100 mm)	100 ~ 1200mm	100 ~ 500mm	150 ~ 350mm
Maximum speed	1200mm/s (Note 1)	1200mm/s	600mm/s
Positioning repeatability	± 0.01 mm		
Lead of ball screw	20mm	20mm	10mm
Motor output	200W	100W	100W, with brake
Resolution	0.01 mm		

Note 1: When the stroke is as given below, the maximum speed differs.

X-axis	Stroke (mm)	Maximum speed (mm/s)
	700	1000
	800	800
	900~1000	600
	1100~1200	400

Acceleration/deceleration time when the maximum speed is set: 0.36 sec. or over

Maximum payload (kg)	Y-axis stroke					
	100mm	200mm	300mm	400mm	500mm	
Z-axis stroke	150mm	7.0	7.0	7.0	4.0	2.0
	250mm	7.0	7.0	6.0	4.0	1.0
	350mm	6.0	6.0	6.0	3.0	1.0

R: Right-handed

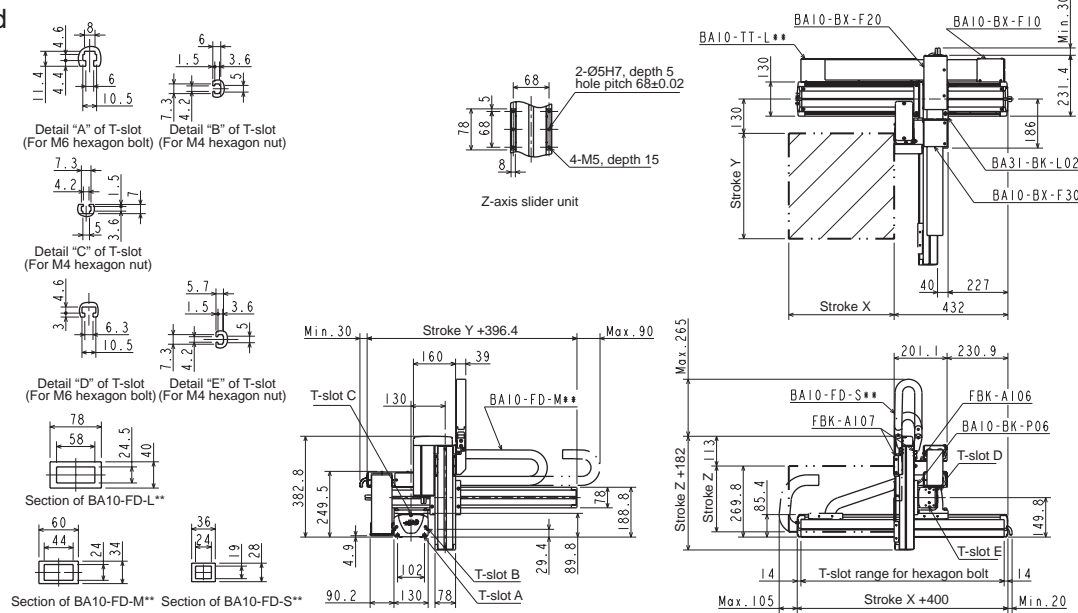

L: Left-handed

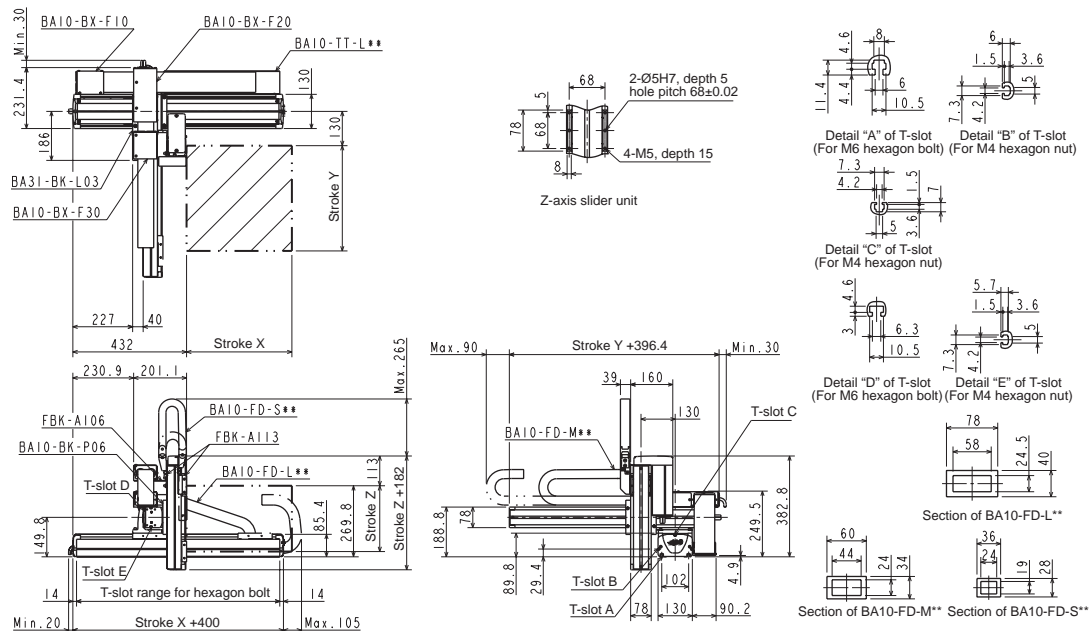

[Set designation]

BA3 - A3 - A3BRE - 40 40 35 - OF 1 3

Combined operation R: Right-handed L: Left-handed	Axis 1 stroke 10 : 100mm 90 : 900mm A0 : 1000mm C0 : 1200mm	Axis 2 stroke 10 : 100mm 50 : 500mm	Axis 3 stroke 15 : 150mm 35 : 350mm	Controller (CA25-M10) 0 : None 1 : NPN output specifications Other : See page 20	Cable length 3 : 3m 9 : 9m 5 : 5m B : 11m 7 : 7m D : 13m
---	---	---	---	---	---

Ball screw type

- X-axis: Ball screw driven
Side mounted motor
- Y-axis: Ball screw driven
Side mounted motor
- Z-axis: Ball screw driven
Side mounted motor

[Specifications]

	X-axis	Y-axis	Z-axis
Type of axis	BE30F-U □-M20N- □0	BE10E-U □-M20N- □0	BE10E-U □-S10B- □5
Stroke (mm) (in increments of 100 mm)	100 ~ 1200mm	100 ~ 500mm	150 ~ 350mm
Maximum speed (mm/s)	1200mm/s (Note 1)	1200mm/s	600mm/s
Positioning repeatability (mm)	± 0.01 mm		
Lead of ball screw (mm)	20mm	20mm	10mm
Motor output	200W	100W	100W, with brake
Resolution (mm)	0.01mm		

Note 1: When the stroke is as given below, the maximum speed differs.

	Stroke (mm)	Maximum speed (mm/s)
X-axis	700	1000
	800	800
	900~1000	600
	1100~1200	400

Acceleration/deceleration time when the maximum speed is set: 0.36 sec. or over

Maximum payload (kg)	Y-axis stroke					
	100mm	200mm	300mm	400mm	500mm	
Z-axis stroke	150mm	7.0	7.0	7.0	4.0	2.0
	250mm	7.0	7.0	6.0	4.0	1.0
	350mm	6.0	6.0	6.0	3.0	1.0

R: Right-handed

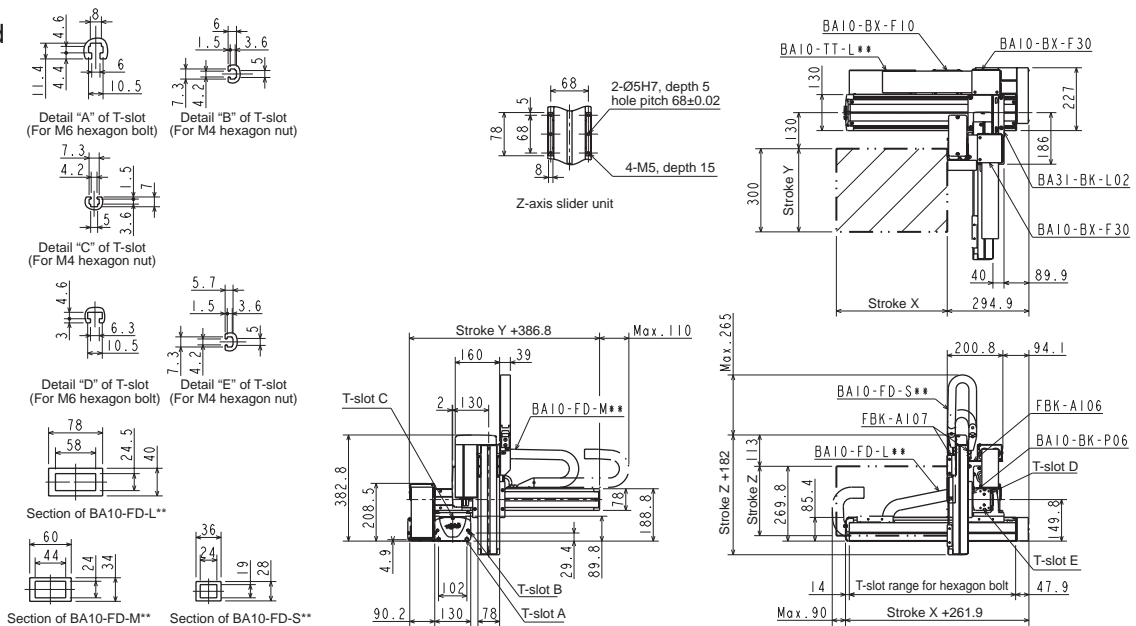

L: Left-handed

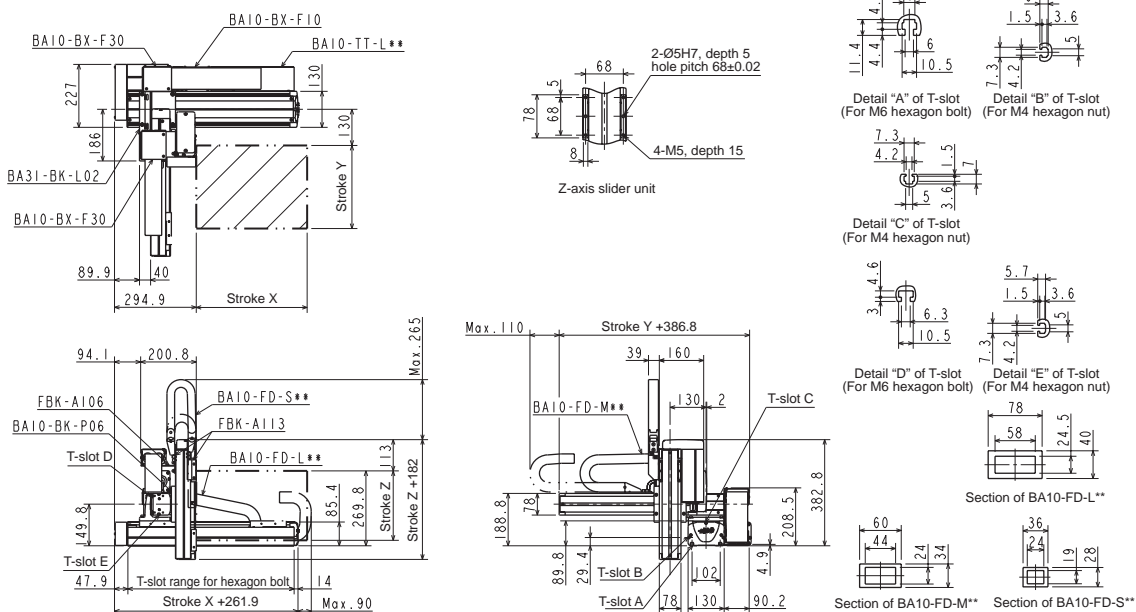

[Set designation]

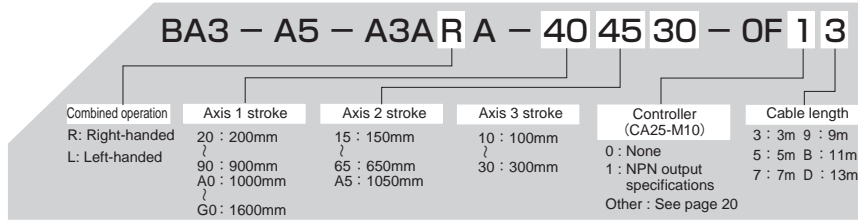

Ball screw type

- X-axis: Ball screw driven
Motor straight
- Y-axis: Ball screw driven
Motor straight
- Z-axis: Ball screw driven
Motor straight

Note 1: When the stroke is as given below, the maximum speed differs.

[Specifications]

	X-axis	Y-axis	Z-axis
Type of axis	BE50F-ST-M20N-□0	BE30E-ST-M20N-□5	BE10E-ST-M05B-□0
Stroke (in increments of 100 mm)	200 ~ 1600mm	150 ~ 1050mm	100 ~ 300mm
Maximum speed	1200mm/s (Note 1)	1200mm/s (Note 1)	300mm/s
Positioning repeatability	± 0.01 mm		
Lead of ball screw	20mm	20mm	5mm
Motor output	200W	100W	100W, with brake
Resolution	0.01mm		

Acceleration/deceleration time when the maximum speed is set: 0.36 sec. or over

	Stroke (mm)	Maximum speed (mm/s)
X-axis	700~800	1100
	900~1000	1000
	1100~1200	700
	1300	500
	1400	400
	1500	300
Y-axis	1600	300
	750	1000
	850	800
	950~1050	600

Maximum payload (kg)	Y-axis stroke										
	150mm	250mm	350mm	450mm	550mm	650mm	750mm	850mm	950mm	1050mm	
Z-axis stroke	100mm	11.0	11.0	11.0	11.0	11.0	11.0	11.0	10.0	8.0	5.0
	200mm	10.0	10.0	10.0	10.0	10.0	10.0	10.0	10.0	7.0	4.0
	300mm	9.0	9.0	9.0	9.0	9.0	9.0	9.0	9.0	6.0	4.0

R: Right-handed

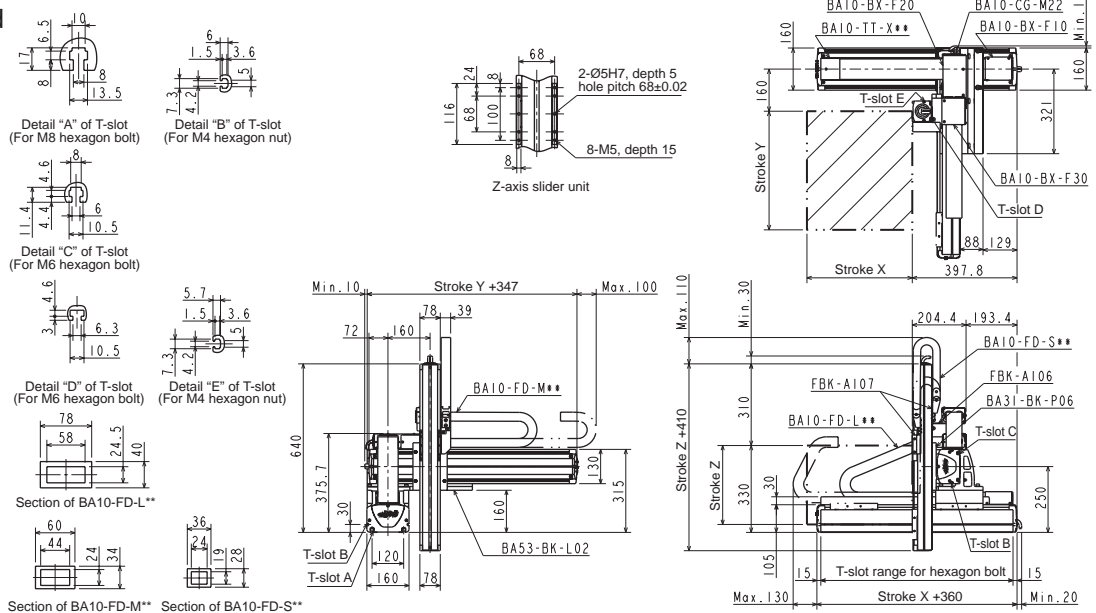

L: Left-handed

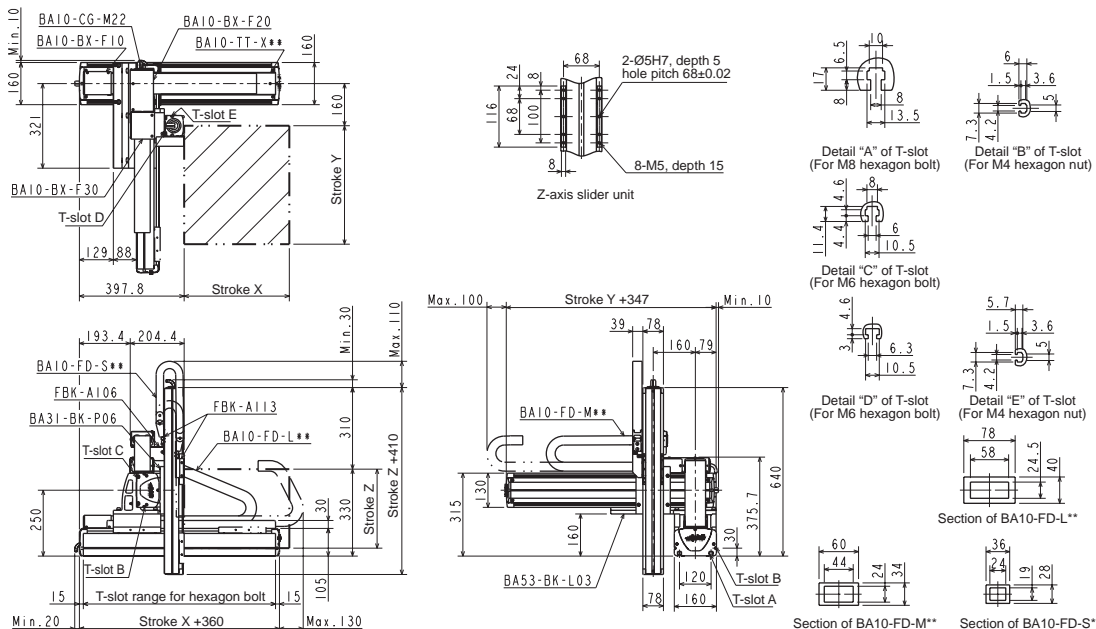

[Set designation]

BA3 – A5 – A3A R G – 40 45 30 – OF 1 3

Combined operation	Axis 1 stroke	Axis 2 stroke	Axis 3 stroke	Controller (CA25-M10)	Cable length
R: Right-handed	20 : 200mm	15 : 150mm	10 : 100mm	0 : None	3 : 3m 9 : 9m
L: Left-handed	90 : 900mm	65 : 650mm	30 : 300mm	1 : NPN output specifications	5 : 5m B : 11m
	A0 : 1000mm	A5 : 1050mm		7 : 7m D : 13m	
	G0 : 1600mm			Other : See page 20	

Ball screw type

- X-axis: Ball screw driven
Side mounted motor
- Y-axis: Ball screw driven
Motor straight
- Z-axis: Ball screw driven
Motor straight

Note 1: When the stroke is as given below, the maximum speed differs.

[Specifications]

	X-axis	Y-axis	Z-axis
Type of axis	BE50F-U □-M20N- □0	BE30E-ST-M20N- □5	BE10E-ST-M05B- □0
Stroke (in increments of 100 mm)	200 ~ 1600mm	150 ~ 1050mm	100 ~ 300mm
Maximum speed	1200mm/s (Note 1)	1200mm/s (Note 1)	300mm/s
Positioning repeatability	± 0.01 mm		
Lead of ball screw	20mm	20mm	5mm
Motor output	200W	100W	100W, with brake
Resolution	0.01mm		

Acceleration/deceleration time when the maximum speed is set: 0.36 sec. or over

	Stroke (mm)	Maximum speed (mm/s)
X-axis	700~800	1100
	900~1000	1000
	1100~1200	700
	1300	500
	1400	400
	1500	300
Y-axis	1600	300
	750	1000
	850	800
	950~1050	600

Maximum payload (kg)	Y-axis stroke										
	150mm	250mm	350mm	450mm	550mm	650mm	750mm	850mm	950mm	1050mm	
Z-axis stroke	100mm	11.0	11.0	11.0	11.0	11.0	11.0	11.0	10.0	8.0	5.0
	200mm	10.0	10.0	10.0	10.0	10.0	10.0	10.0	10.0	7.0	4.0
	300mm	9.0	9.0	9.0	9.0	9.0	9.0	9.0	9.0	6.0	4.0

R: Right-handed

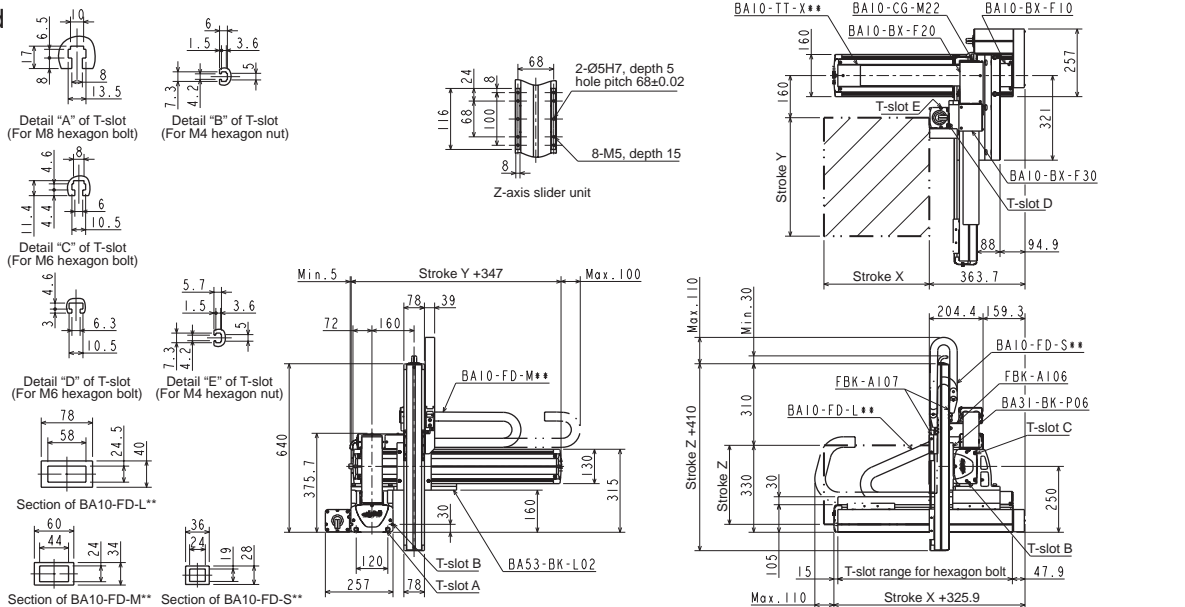

L: Left-handed

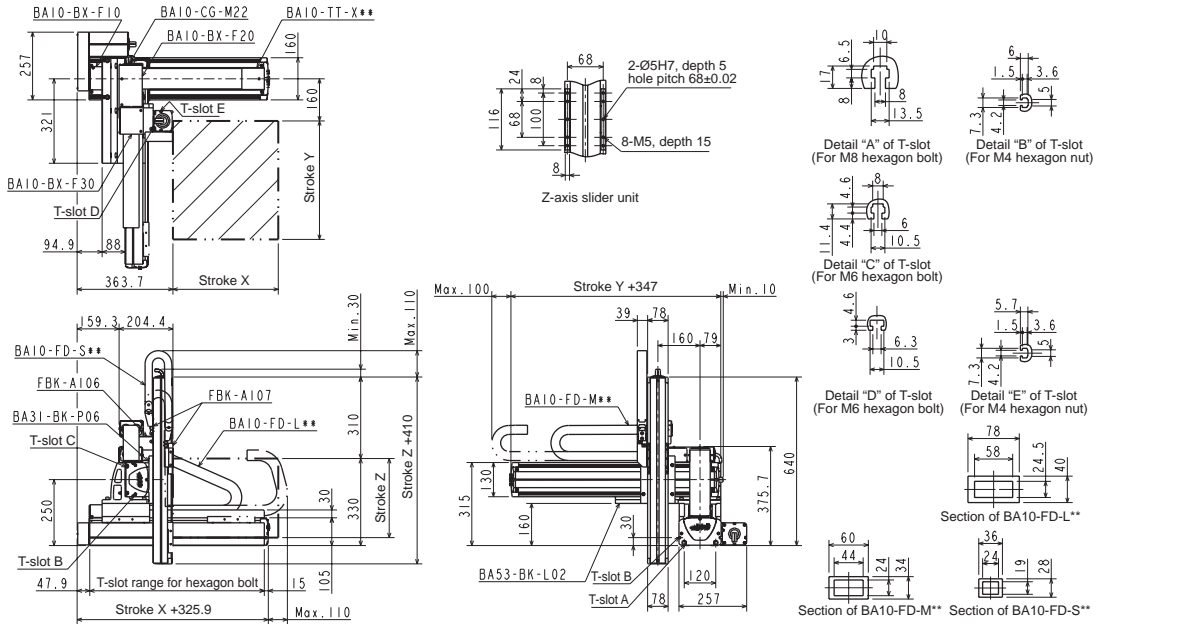

X-Y-Z Flexible-duct Spec.

[Set designation]

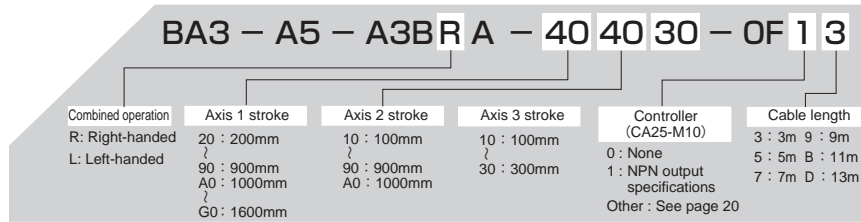

Ball screw type

- X-axis: Ball screw driven
Motor straight
- Y-axis: Ball screw driven
Motor straight
- Z-axis: Ball screw driven
Motor straight

Note 1: When the stroke is as given below, the maximum speed differs.

[Specifications]

	X-axis	Y-axis	Z-axis
Type of axis	BE50F-ST-M20N-□□	BE30F-ST-M20N-□□	BE10E-ST-M05B-□□
Stroke (in increments of 100 mm)	200 ~ 1600mm	100 ~ 1000mm	100 ~ 300mm
Maximum speed	1200mm/s (Note 1)	1200mm/s (Note 1)	300mm/s
Positioning repeatability	± 0.01 mm		
Lead of ball screw	20mm	20mm	5mm
Motor output	200W	200W	100W, with brake
Resolution	0.01mm		

Acceleration/deceleration time when the maximum speed is set: 0.36 sec. or over

	Stroke (mm)	Maximum speed (mm/s)
X-axis	700~800	1100
	900~1000	1000
	1100~1200	700
	1300	500
	1400	400
	1500	300
Y-axis	1600	300
	700	1000
	800	800
	900~1000	600

Maximum payload (kg)	Z-axis stroke	Y-axis stroke									
		100mm	200mm	300mm	400mm	500mm	600mm	700mm	800mm	900mm	1000mm
100mm	100mm	15.0	15.0	15.0	15.0	15.0	15.0	14.0	11.0	8.0	5.0
	200mm	15.0	15.0	15.0	15.0	15.0	15.0	13.0	10.0	7.0	5.0
	300mm	15.0	15.0	15.0	15.0	15.0	15.0	12.0	10.0	7.0	4.0

R: Right-handed

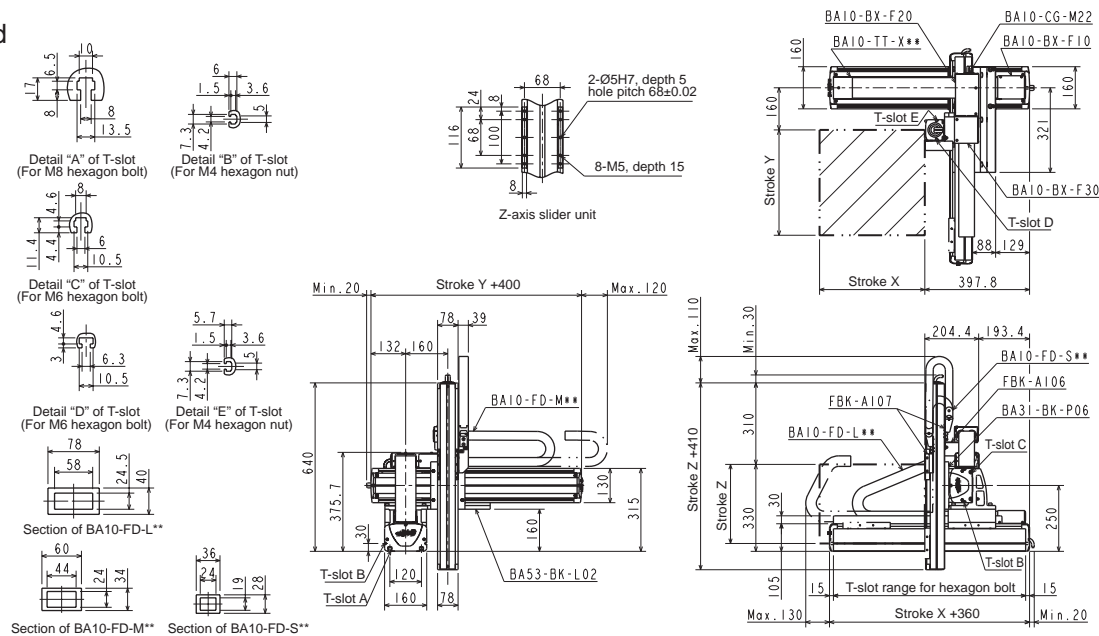

L: Left-handed

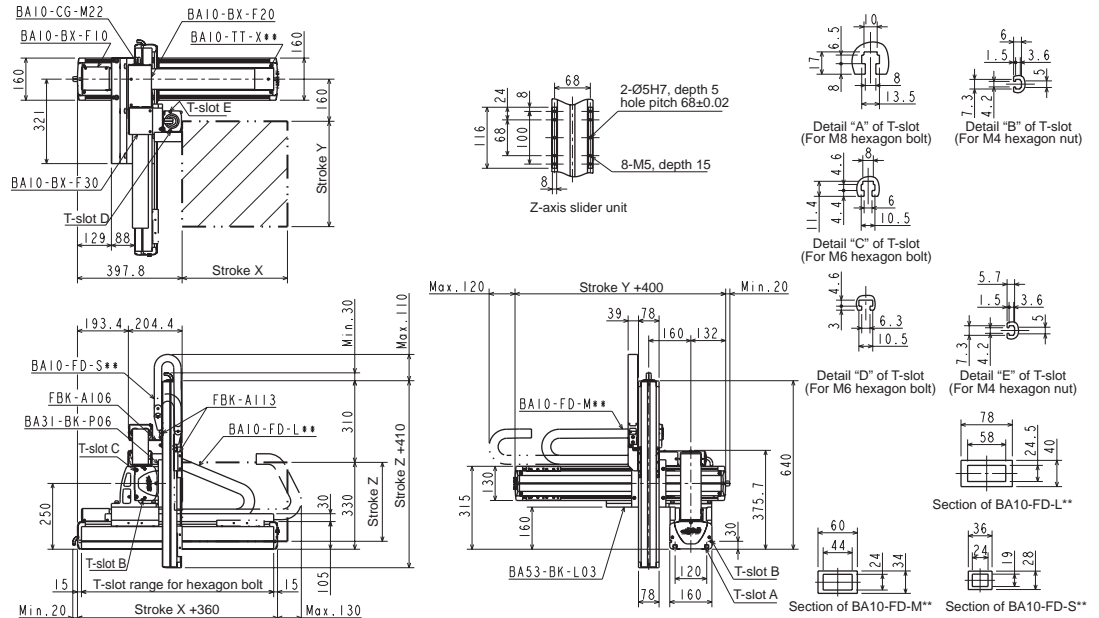

[Set designation]

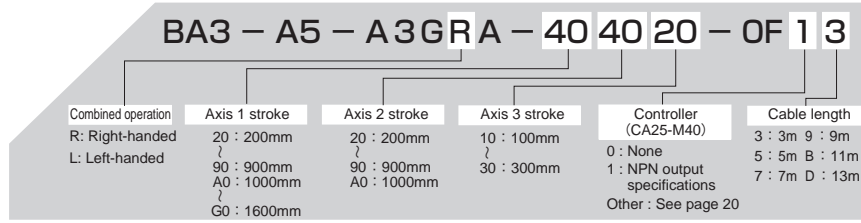

Ball screw type

- X-axis: Ball screw driven Motor straight
- Y-axis: Ball screw driven Motor straight
- Z-axis: Ball screw driven Motor straight

Note 1: When the stroke is as given below, the maximum speed differs.

[Specifications]

Type of axis	X-axis	Y-axis	Z-axis
Stroke (mm) (in increments of 100 mm)	BE50G-ST-M20N-□0	BE50F-ST-M20N-□0	BE30F-ST-M05B-□0
Maximum speed (mm/s)	200 ~ 1600	200 ~ 1000	100 ~ 300
Positioning repeatability (mm)	±0.01		
Lead of ball screw (mm)	20	20	5
Motor output	400W	200W	200W, with brake
Resolution (mm)	0.01		

	Stroke (mm)	Maximum speed (mm/s)
X-axis	700~800	1100
	900~1000	1000
	1100~1200	700
	1300	500
	1400	400
	1500	300
Y-axis	1600	300
	700~800	1100
	900~1000	1000

Acceleration/deceleration time when the maximum speed is set: 0.36 sec. or over

Maximum payload (kg)	Y-axis stroke									
	200mm	300mm	400mm	500mm	600mm	700mm	800mm	900mm	1000mm	
Z-axis stroke 100mm	40.0	40.0	32.5	26.0	20.5	16.0	11.5	8.0	1.3	
Z-axis stroke 200mm	40.0	38.5	31.0	24.5	19.5	14.5	10.5	7.0	—	
Z-axis stroke 300mm	40.0	37.0	29.5	23.5	18.0	13.5	9.5	5.5	—	

The regenerative discharge unit ABSU-4000 is required for the X-axis, and the regenerative discharge unit ABSU-2000 is required for the Z-axis.

R: Right-handed

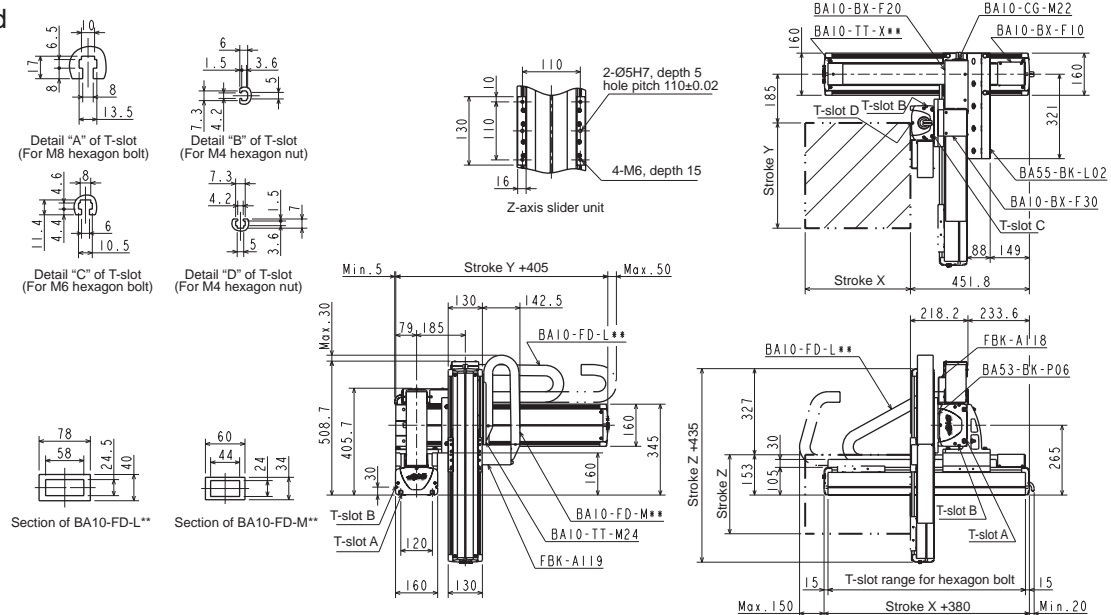

L: Left-handed

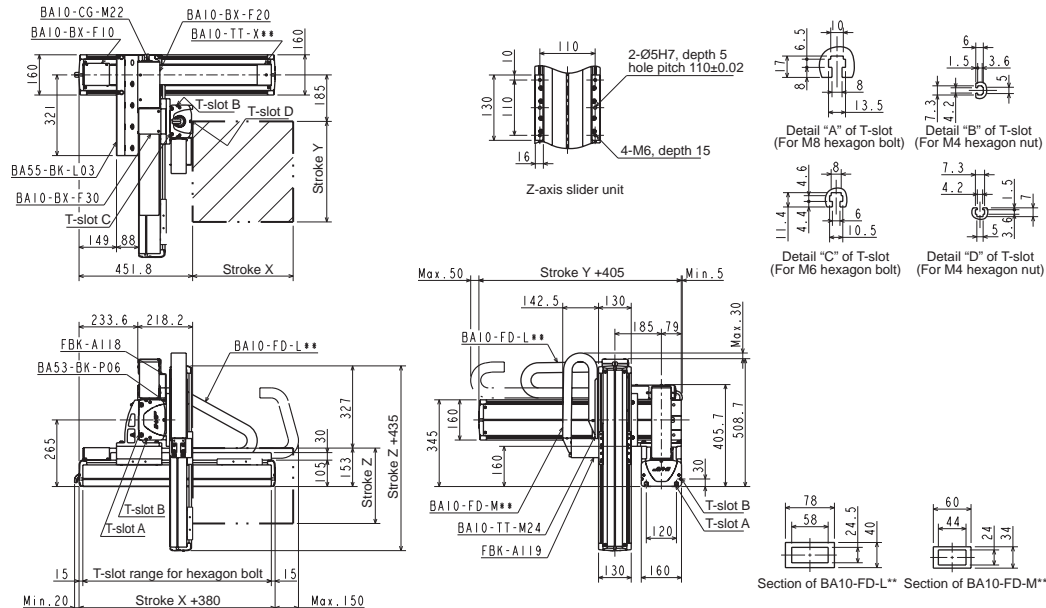

[Set designation]

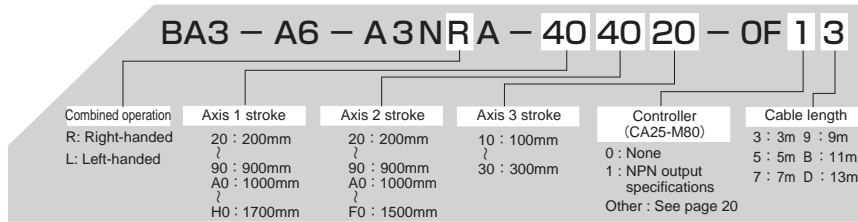

Ball screw type

- X-axis: Ball screw driven
Motor straight
- Y-axis: Ball screw driven
Motor straight
- Z-axis: Ball screw driven
Motor straight

Note 1: When the stroke is as given below, the maximum speed differs.

[Specifications]

	X-axis	Y-axis	Z-axis
Type of axis	BE60J-ST-M20N-□□	BE50G-ST-M20N-□□	BE30F-ST-M05B-□□
Stroke (mm) (in increments of 100 mm)	200 ~ 1700	200 ~ 1500	100 ~ 300
Maximum speed (mm/s)	900 (Note 1)	1200 (Note 1)	300
Positioning repeatability (mm)	±0.01		
Lead of ball screw (mm)	20	20	5
Motor output	750W	400W	200W, with brake
Resolution (mm)	0.01		

Acceleration/deceleration time when the maximum speed is set: 0.36 sec. or over

	Stroke (mm)	Maximum speed (mm/s)
X-axis	1100	700
	1200	600
	1300	500
	1400~1500	400
	1600~1700	300
Y-axis	700~800	1100
	900~1000	1000
	1100~1200	700
	1300	500
	1400	400
	1500	300

Maximum payload (kg)	Z-axis stroke	Y-axis stroke														
		200mm	300mm	400mm	500mm	600mm	700mm	800mm	900mm	1000mm	1100mm	1200mm	1300mm	1400mm	1500mm	
100mm	100mm	40.0	40.0	40.0	40.0	40.0	40.0	40.0	35.0	30.0	21.3	14.3	9.3	5.3	2.3	
	200mm	40.0	40.0	40.0	40.0	40.0	40.0	39.5	34.0	28.5	20.1	13.1	8.1	4.1	1.1	
	300mm	40.0	40.0	40.0	40.0	40.0	40.0	38.0	32.5	27.5	18.9	11.9	6.9	2.9	—	

Regenerative discharge units are required for all axes.

- 1) X-axis: Regenerative discharge unit Model: ABSU-8000
- 2) Y-axis: Regenerative discharge unit Model: ABSU-4000
- 3) Z-axis: Regenerative discharge unit Model: ABSU-2000

R: Right-handed

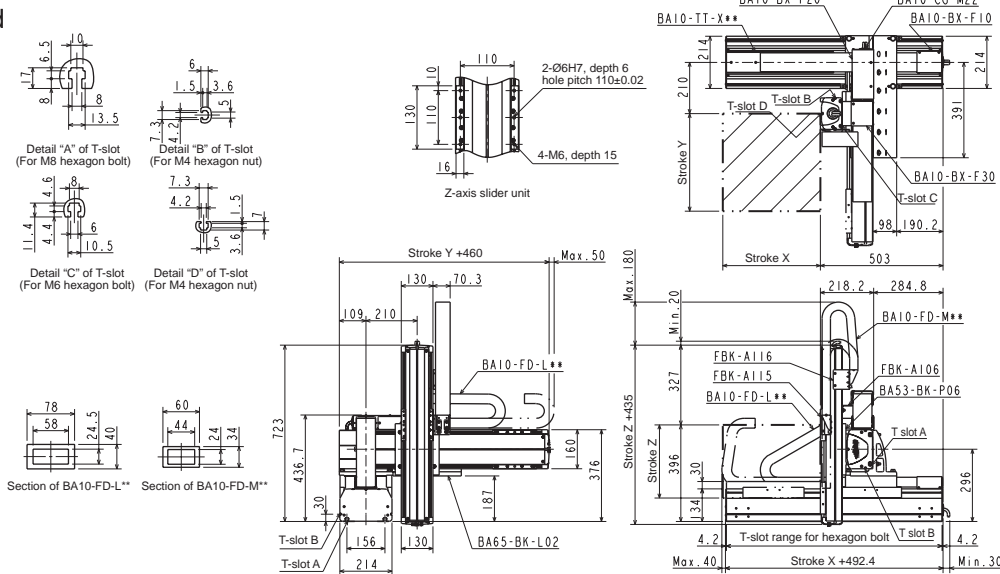

L: Left-handed

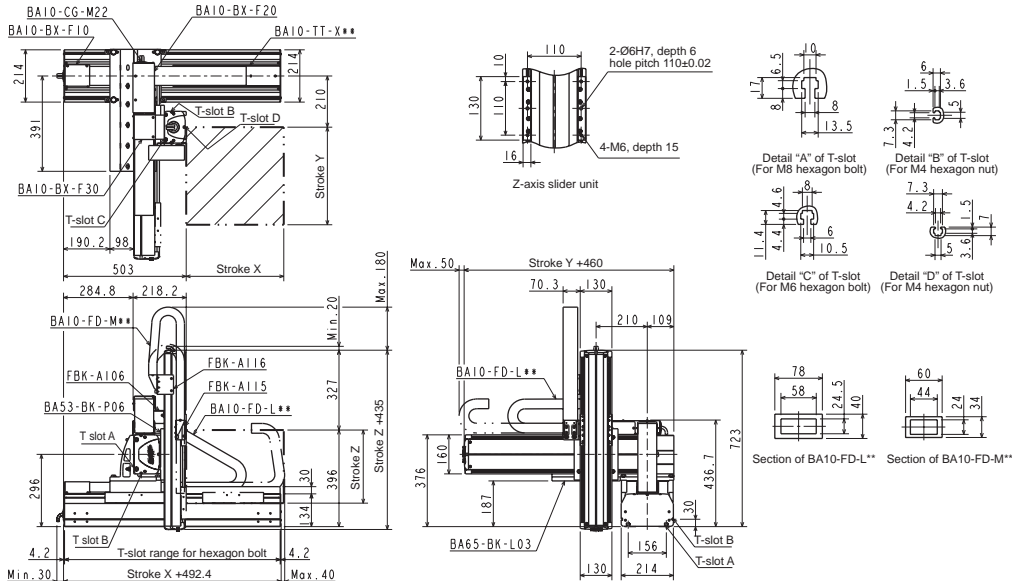

[Set designation]

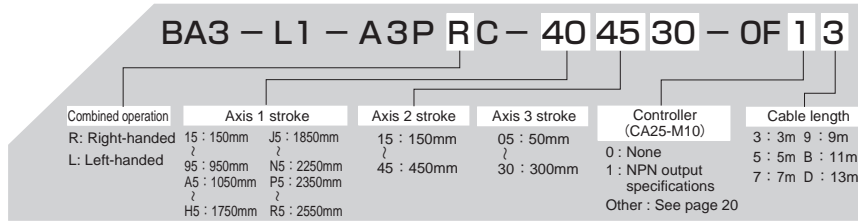

Timing belt type

- X-axis: Timing belt driven
Side mounted motor
- Y-axis: Timing belt driven
Side mounted motor
- Z-axis: Ball screw driven
Motor straight

[Specifications]

	X-axis	Y-axis	Z-axis
Type of axis	BE10F-BT-M21N-□0	BE10E-B□-S21N-□5	BET7D-ST-M06B-□□
Stroke (mm) (X- and Y-axis in increments of 100 mm, Z-axis in increments of 50mm)	150 ~ 2550	150 ~ 450	50 ~ 300
Maximum speed (mm/s)	1000	1000	400
Positioning repeatability (mm)	± 0.04	± 0.04	± 0.02
Lead of ball screw (mm)	21 (lead converted into ball screw)	21 (lead converted into ball screw)	6
Motor output	200W	100W	50W, with brake
Resolution (mm)	0.01		

Acceleration/deceleration time when the maximum speed is set: 0.3 sec. or over

Maximum payload (kg)	Y-axis stroke			
	150mm	250mm	350mm	450mm
Z-axis stroke				
50,100mm	4.0	3.5	2.5	1
150,200mm	4.0	2.5	2	0.6
250,300mm	3.5	2.5	1.5	0.2

R: Right-handed

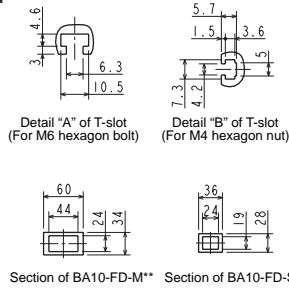

The values in parentheses are applicable when the X-axis stroke is 1,050 mm or over.

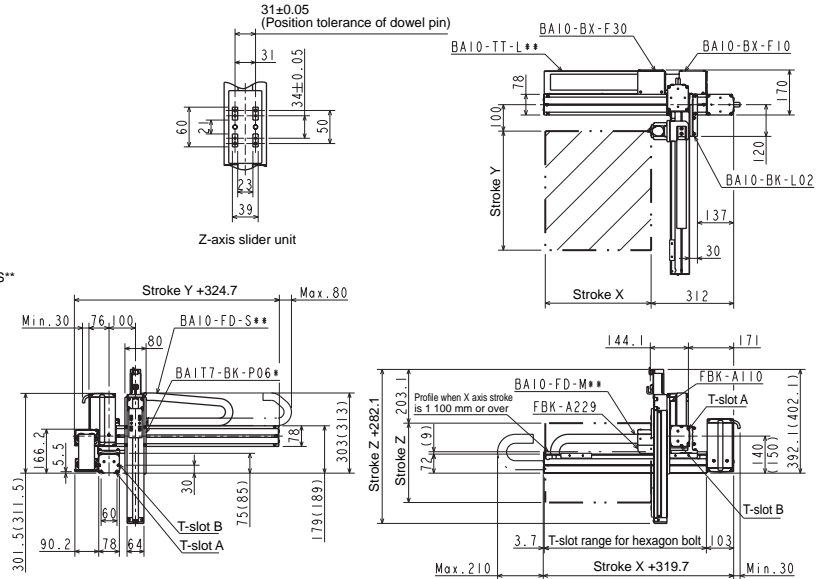

L: Left-handed

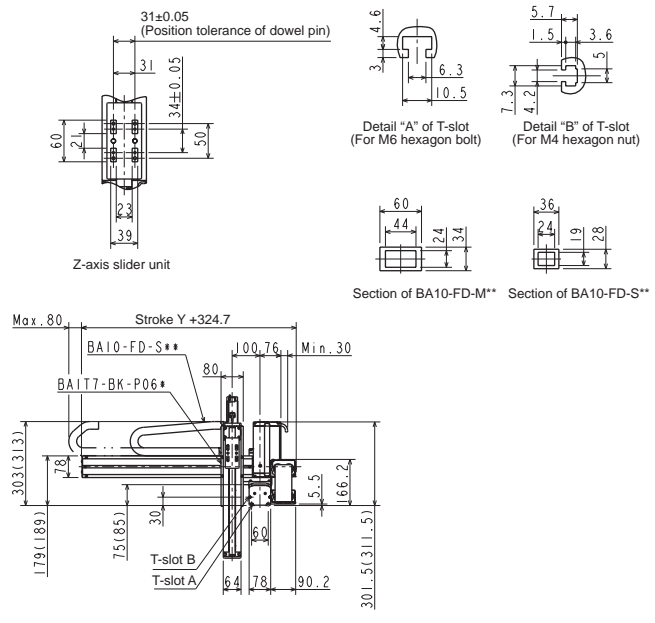
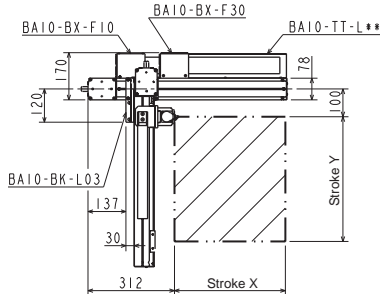

[Set designation]

BA3 - L3 - A3N RC - 40 45 30 - OF 1 3

Combined operation	Axis 1 stroke	Axis 2 stroke	Axis 3 stroke	Controller (CA25-M10)	Cable length
R: Right-handed	10 : 100mm J0 : 1800mm	15 : 150mm	05 : 50mm	0 : None	3 : 3m 9 : 9m
L: Left-handed	90 : 900mm A0 : 1000mm H0 : 1700mm	NO : 2200mm PO : 2300mm VO : 2900mm W0 : 3000mm W20 : 3200mm	85 : 850mm 30 : 300mm	1 : NPN output specifications Other : See page 20	5 : 5m B : 11m 7 : 7m D : 13m

Timing belt type

- X-axis: Timing belt driven
Side mounted motor
- Y-axis: Timing belt driven
Side mounted motor
- Z-axis: Ball screw driven
Motor straight

[Specifications]

	X-axis	Y-axis	Z-axis
Type of axis	BE30F-BT-M21N-□0	BE10E-B□-S21N-□5	BET7D-ST-M06B-□□
Stroke (mm) (X- and Y-axis in increments of 100 mm, Z-axis in increments of 50mm)	100 ~ 3200	150 ~ 750	50 ~ 300
Maximum speed (mm/s)	1000	1000	400
Positioning repeatability (mm)	± 0.04	± 0.04	± 0.02
Lead of ball screw (mm)	21 (lead converted into ball screw)	21 (lead converted into ball screw)	6
Motor output	200W	100W	50W, with brake
Resolution (mm)	0.01		

Acceleration/deceleration time when the maximum speed is set: 0.3 sec. or over

Maximum payload (kg)	Y-axis stroke						
	150mm	250mm	350mm	450mm	550mm	650mm	750mm
Z-axis stroke							
50,100mm	4.0	4.0	4.0	4.0	3.9	3.4	1.6
150,200mm	4.0	4.0	4.0	4.0	3.7	3.1	1.3
250,300mm	4.0	4.0	4.0	4.0	3.5	2.8	1

R: Right-handed

The values in parentheses are applicable when the X-axis stroke is 1,850 mm or over.

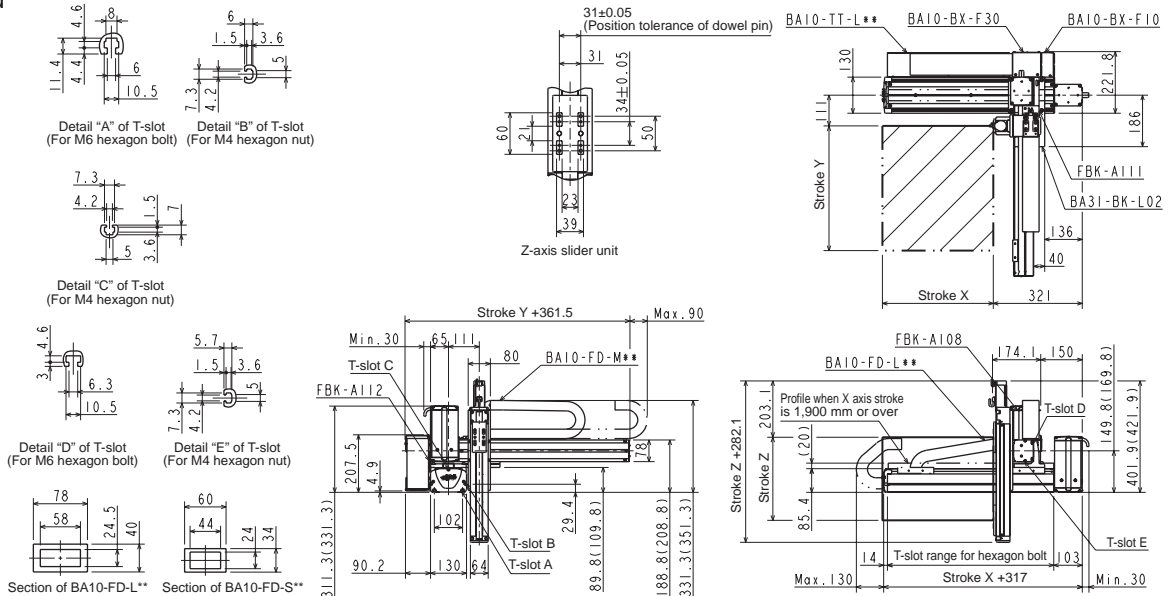

L: Left-handed

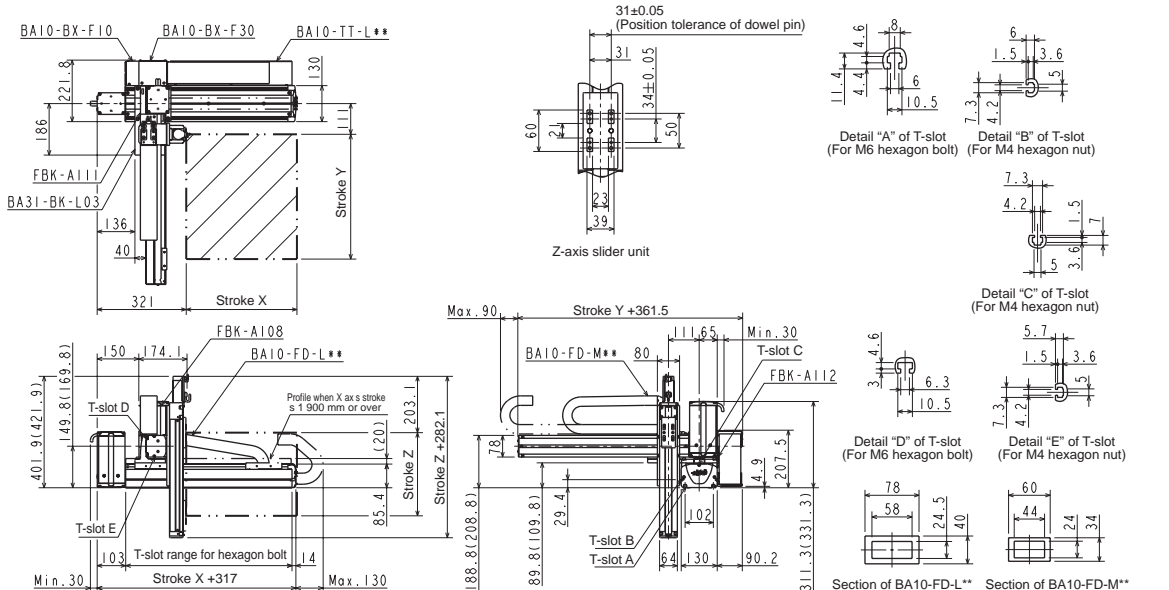

[Set designation]

BA3 - L3 - A3B R D - 40 40 35 - OF 1 3

Combined operation	Axis 1 stroke	Axis 2 stroke	Axis 3 stroke	Controller (CA25-M10)	Cable length
R: Right-handed	10 : 100mm J0 : 1800mm	10 : 100mm	15 : 150mm	0 : None	3 : 3m 9 : 9m
L: Left-handed	90 : 900mm A0 : 1000mm H0 : 1700mm	50 : 500mm	35 : 350mm	1 : NPN output specifications Other : See page 20	5 : 5m B : 11m 7 : 7m D : 13m
	N0 : 2200mm P0 : 2300mm V0 : 2900mm W0 : 3000mm W20 : 3200mm				

Timing belt type

- X-axis: Timing belt driven
Side mounted motor
- Y-axis: Timing belt driven
Side mounted motor
- Z-axis: Ball screw driven
Side mounted motor

[Specifications]

	X-axis	Y-axis	Z-axis
Type of axis	BE30F-BT-M21N-□0	BE10E-B□-M21N-□0	BE10E-U□-S10B-□5
Stroke (in increments of 100 mm)	100 ~ 3200mm	100 ~ 500mm	150 ~ 350mm
Maximum speed	1000mm/s	1000mm/s	600mm/s
Positioning repeatability	± 0.04mm	± 0.04mm	± 0.01mm
Lead	21mm (lead converted into ball screw)	21mm (lead converted into ball screw)	10mm
Motor output	200W	100W	100W, with brake
Resolution		0.01mm	

Acceleration/deceleration time when the maximum speed is set: 0.36 sec. or over

Maximum payload (kg)	Z-axis stroke	Y-axis stroke				
		100mm	200mm	300mm	400mm	500mm
150mm	150mm	8.0	8.0	7.0	4.0	2.0
	250mm	7.0	7.0	6.0	4.0	1.0
	350mm	6.0	6.0	6.0	3.0	1.0

R: Right-handed

The values in parentheses are applicable when the X-axis stroke is 1,850 mm or over.

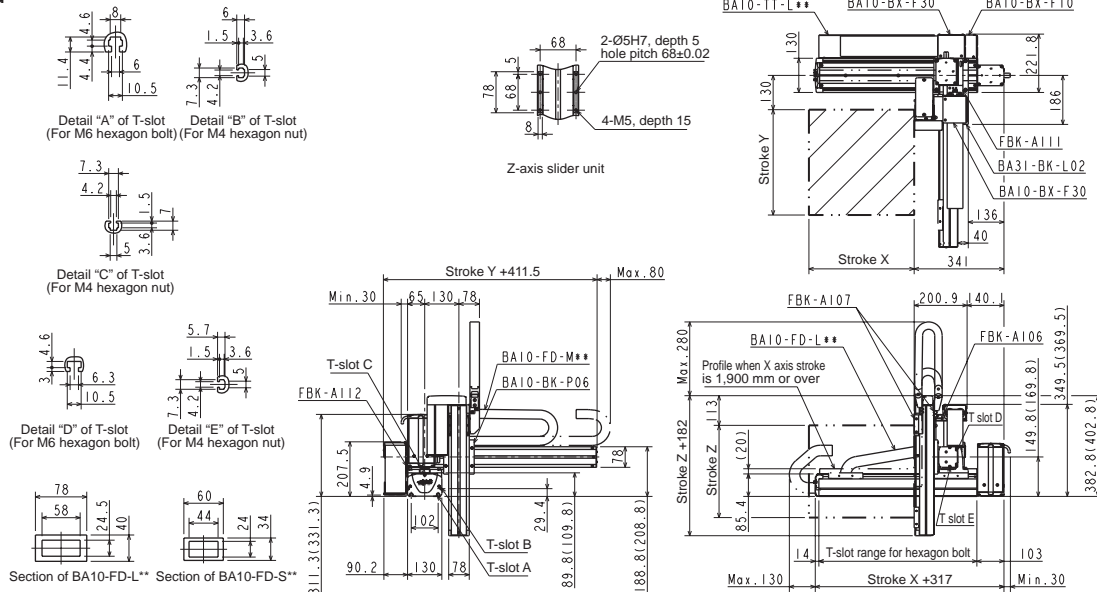

L: Left-handed

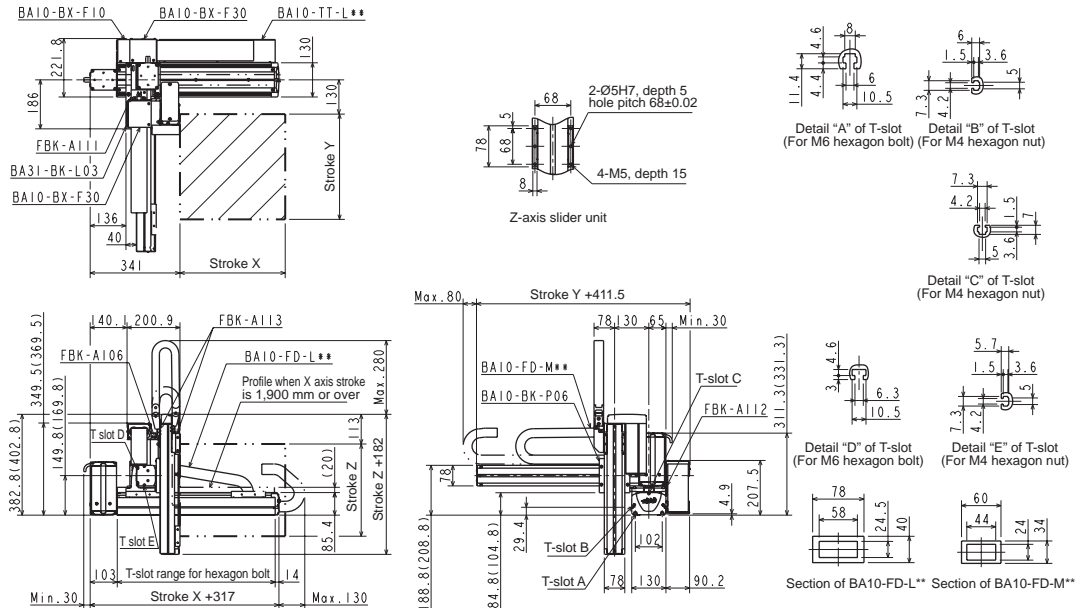

[Set designation]

BA3 - L5 - A3A R C - 40 40 30 - OF 1 3

Combined operation	Axis 1 stroke	Axis 2 stroke	Axis 3 stroke	Controller (CA25-M10)	Cable length
R: Right-handed	20 : 200mm JO : 1800mm	10 : 100mm	10 : 100mm	0 : None	3 : 3m 9 : 9m
L: Left-handed	90 : 900mm NO : 2200mm AO : 1000mm PO : 2300mm HO : 1700mm VO : 2900mm WQ : 3000mm W50 : 3500mm	90 : 900mm AO : 1000mm	? 30 : 300mm	1 : NPN output specifications Other : See page 20	5 : 5m B : 11m 7 : 7m D : 13m

Timing belt type

- X-axis: Timing belt driven
Side mounted motor
- Y-axis: Timing belt driven
Side mounted motor
- Z-axis: Ball screw driven
Motor straight

[Specifications]

	X-axis	Y-axis	Z-axis
Type of axis	BE50F-BT-M21N-□0	BE30E-B□-M21N-□0	BE10E-ST-M05B-□0
Stroke (in increments of 100 mm)	200 ~ 3500mm	100 ~ 1000mm	100 ~ 300mm
Maximum speed	1000mm/s	1000mm/s	300mm/s
Positioning repeatability	± 0.04mm	± 0.04mm	± 0.01mm
Lead	21mm (lead converted into ball screw)	21mm (lead converted into ball screw)	5mm
Motor output	200W	100W	100W, with brake
Resolution	0.01mm		

Acceleration/deceleration time when the maximum speed is set: 0.36 sec. or over

Maximum payload (kg)	Z-axis stroke	Y-axis stroke									
		100mm	200mm	300mm	400mm	500mm	600mm	700mm	800mm	900mm	1000mm
100mm	100mm	7.0	7.0	7.0	7.0	7.0	7.0	7.0	7.0	6.0	5.0
	200mm	7.0	7.0	7.0	7.0	7.0	7.0	7.0	7.0	5.0	4.0
	300mm	6.0	6.0	6.0	6.0	6.0	6.0	6.0	6.0	5.0	4.0

R: Right-handed

The values in parentheses are applicable when the X-axis stroke is 1,850 mm or over.

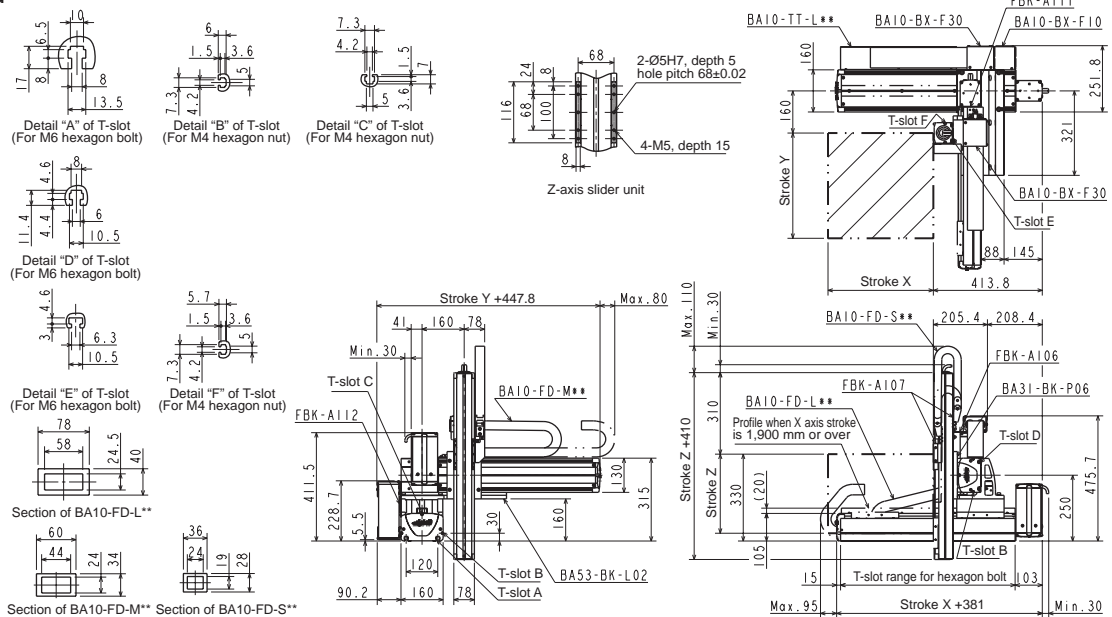

L: Left-handed

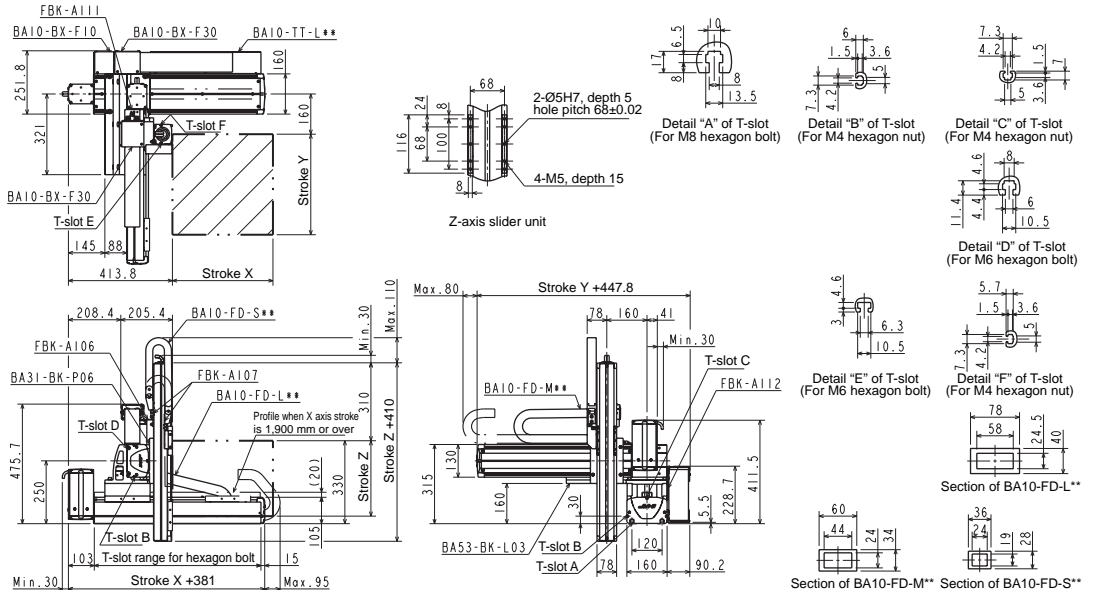

[Set designation]

BA3 - L5 - A3B R C - 40 40 30 - OF 1 3

Combined operation R: Right-handed L: Left-handed	Axis 1 stroke 20 : 200mm 90 : 900mm A0 : 1000mm H0 : 1700mm	Axis 2 stroke 10 : 100mm 90 : 900mm A0 : 1000mm	Axis 3 stroke 10 : 100mm 30 : 300mm	Controller (CA25-M10) 0 : None 1 : NPN output specifications Other : See page 20	Cable length 3 : 3m 9 : 9m 5 : 5m B : 11m 7 : 7m D : 13m
	JO : 1800mm NO : 2200mm PO : 2300mm VO : 2900mm W0 : 3000mm W50 : 3500mm				

Timing belt type

- X-axis: Timing belt driven
Side mounted motor
- Y-axis: Timing belt driven
Side mounted motor
- Z-axis: Ball screw driven
Motor straight

[Specifications]

	X-axis	Y-axis	Z-axis
Type of axis	BE50F-BT-M21N-□0	BE30F-B□-M21N-□0	BE10E-ST-M05B-□0
Stroke (in increments of 100 mm)	200 ~ 3500mm	100 ~ 1000mm	100 ~ 300mm
Maximum speed	1000mm/s	1000mm/s	300mm/s
Positioning repeatability	± 0.04mm	± 0.04mm	± 0.01mm
Lead	21mm (lead converted into ball screw)	21mm (lead converted into ball screw)	5mm
Motor output	200W	200W	100W, with brake
Resolution		0.01mm	

Acceleration/deceleration time when the maximum speed is set: 0.36 sec. or over

Maximum payload (kg)	Z-axis stroke	Y-axis stroke									
		100mm	200mm	300mm	400mm	500mm	600mm	700mm	800mm	900mm	1000mm
100mm	100mm	14.0	13.0	12.0	11.0	9.0	8.0	6.0	6.0	5.0	4.0
	200mm	13.0	12.0	11.0	10.0	8.0	7.0	6.0	6.0	5.0	4.0
	300mm	13.0	12.0	11.0	9.0	7.0	6.0	5.0	5.0	4.0	3.0

R: Right-handed

The values in parentheses are applicable when the X-axis stroke is 1,850 mm or over.

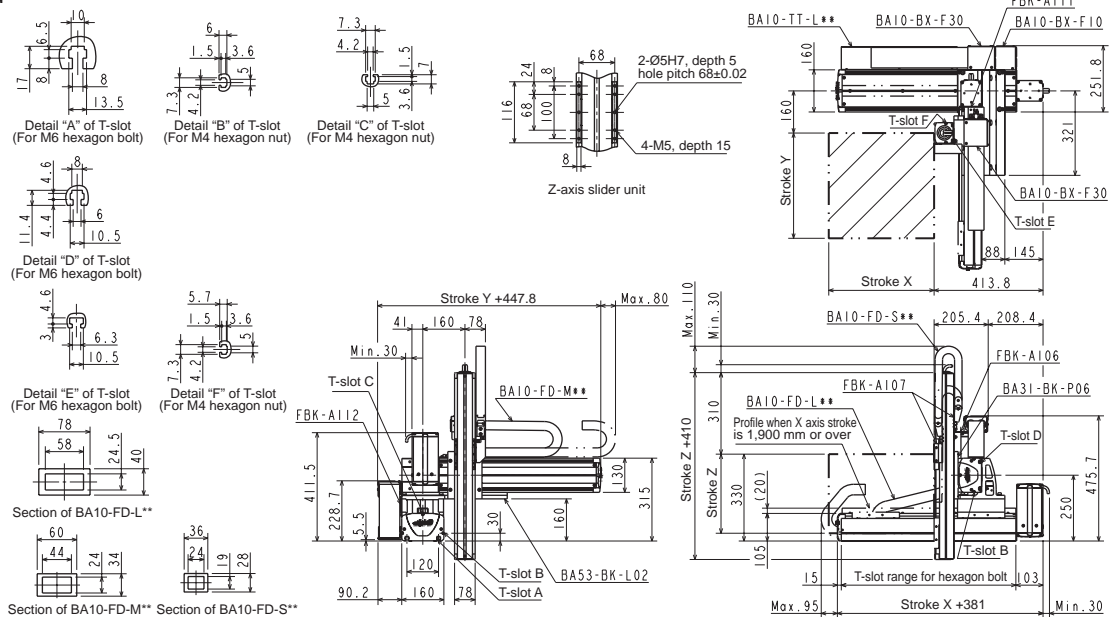

L: Left-handed

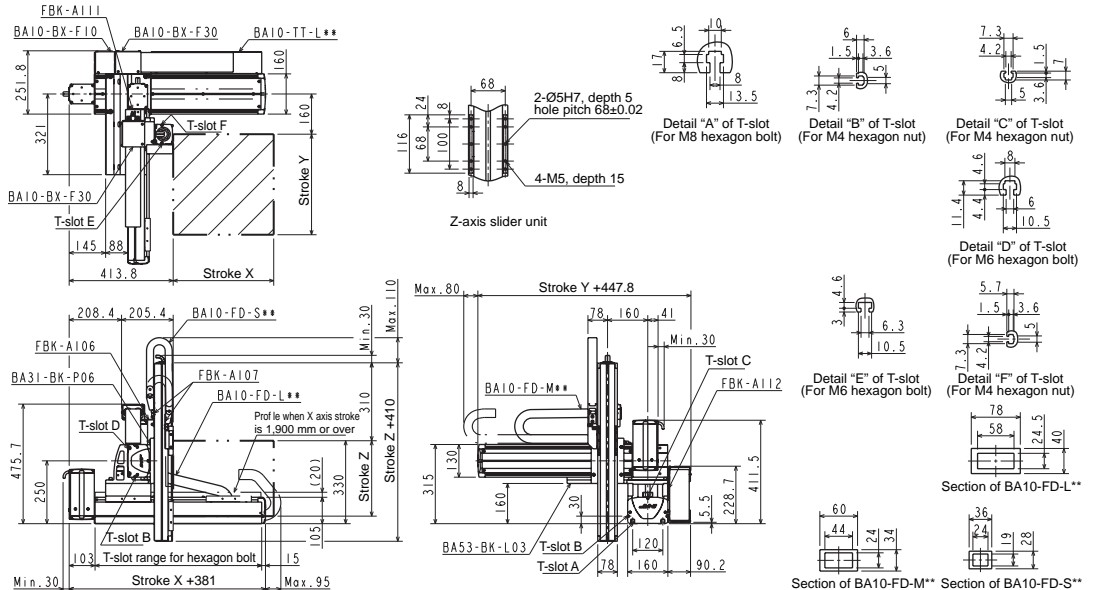

[Set designation]

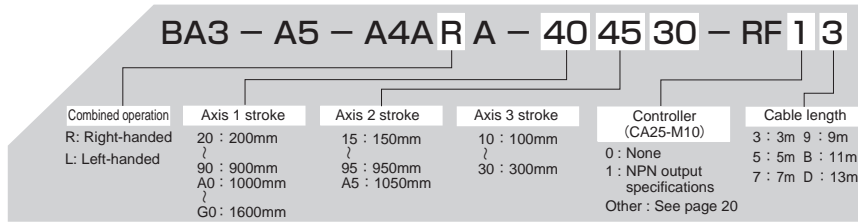

Harmonic drive type

X-axis: Ball screw driven Motor straight
Y-axis: Ball screw driven Motor straight
Z-axis: Ball screw driven Motor straight
R-axis: Harmonic drive

Note 1: When the stroke is as given below, the maximum speed differs.

[Specifications]

	X-axis	Y-axis	Z-axis	R-axis
Type of axis	BE50F-ST-M20N-□0	BE30E-ST-M20N-□5	BE10E-ST-M05B-□0	BE00D-RH-A
Stroke (in increments of 100 mm)	200 ~ 1600mm	150 ~ 1050mm	100 ~ 300mm	360°
Maximum speed	1200mm/s (Note 1)	1200mm/s (Note 1)	300mm/s	360°/s
Positioning repeatability	± 0.01mm	± 0.01mm	± 0.01mm	± 0.025°
Lead of ball screw	20mm	20mm	5mm	1/50 (Reduction ratio)
Motor output	200W	100W	100W, with brake	50W
Resolution	0.01 mm (R-axis: 0.01 deg.)			

Acceleration/deceleration time when the maximum speed is set: 0.36 sec. or over

	Stroke (mm)	Maximum speed (mm/s)
X-axis	700~800	1100
	900~1000	1000
	1100~1200	700
	1300	500
	1400	400
	1500	300
	1600	300
Y-axis	750	1000
	850	800
	950~1050	600

Maximum payload (kg)	Z-axis stroke	Y-axis stroke									
		150mm	250mm	350mm	450mm	550mm	650mm	750mm	850mm	950mm	1050mm
100mm	100mm	5.0	5.0	5.0	5.0	5.0	5.0	5.0	5.0	5.0	3.0
	200mm	5.0	5.0	5.0	5.0	5.0	5.0	5.0	5.0	4.0	2.0
	300mm	5.0	5.0	5.0	5.0	5.0	5.0	5.0	5.0	4.0	1.0

R: Right-handed

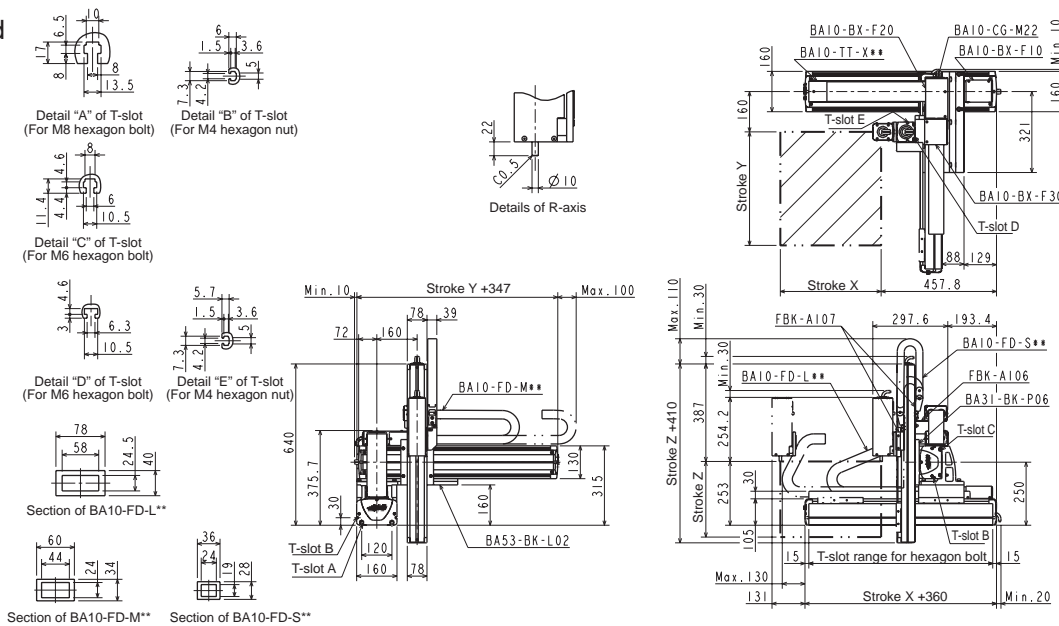

L: Left-handed

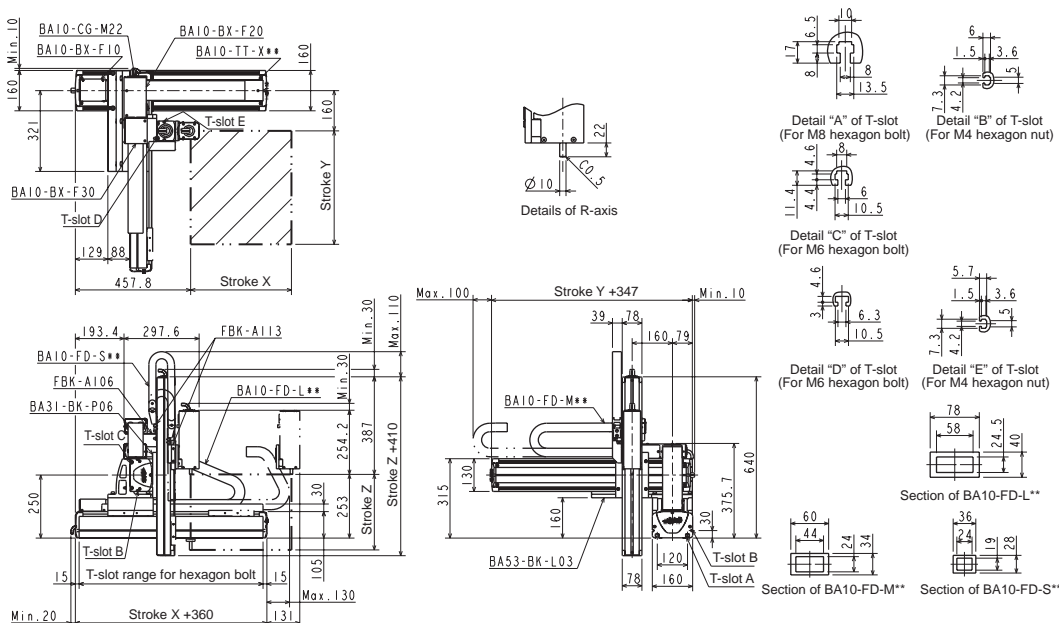

[Set designation]

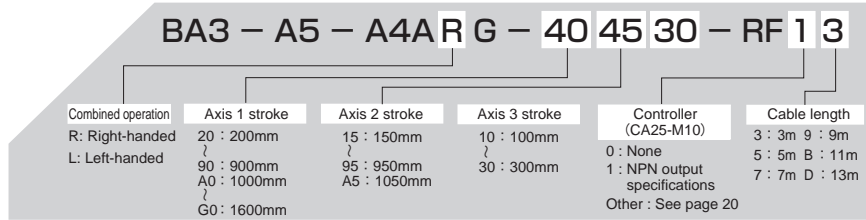

Harmonic drive type

X-axis: Ball screw driven Side mounted motor
Y-axis: Ball screw driven Motor straight
Z-axis: Ball screw driven Motor straight
R-axis: Harmonic drive

Note 1: When the stroke is as given below, the maximum speed differs.

[Specifications]

	X-axis	Y-axis	Z-axis	R-axis
Type of axis	BE50F-U □-M20-□□	BE30E-ST-M20N-□□5	BE10E-ST-M05B-□□0	BE00D-RH-A
Stroke (in increments of 100 mm)	200 ~ 1600mm	150 ~ 1050mm	100 ~ 300mm	360°
Maximum speed	1200mm/s (Note 1)	1200mm/s (Note 1)	300mm/s	360°/s
Positioning repeatability	± 0.01mm	± 0.01mm	± 0.01mm	± 0.025°
Lead of ball screw	20mm	20mm	5mm	1/50 (Reduction ratio)
Motor output	200W	100W	100W, with brake	50W
Resolution	0.01mm (R-axis: 0.01 deg.)			

Acceleration/deceleration time when the maximum speed is set: 0.36 sec. or over

	Stroke (mm)	Maximum speed (mm/s)
X-axis	700~800	1100
	900~1000	1000
	1100~1200	700
	1300	500
	1400	400
	1500	300
Y-axis	1600	300
	750	1000
	850	800
	950~1050	600

Maximum payload (kg)	Z-axis stroke	Y-axis stroke									
		150mm	250mm	350mm	450mm	550mm	650mm	750mm	850mm	950mm	1050mm
100mm	100mm	5.0	5.0	5.0	5.0	5.0	5.0	5.0	5.0	5.0	3.0
	200mm	5.0	5.0	5.0	5.0	5.0	5.0	5.0	5.0	4.0	2.0
	300mm	5.0	5.0	5.0	5.0	5.0	5.0	5.0	5.0	4.0	1.0

R: Right-handed

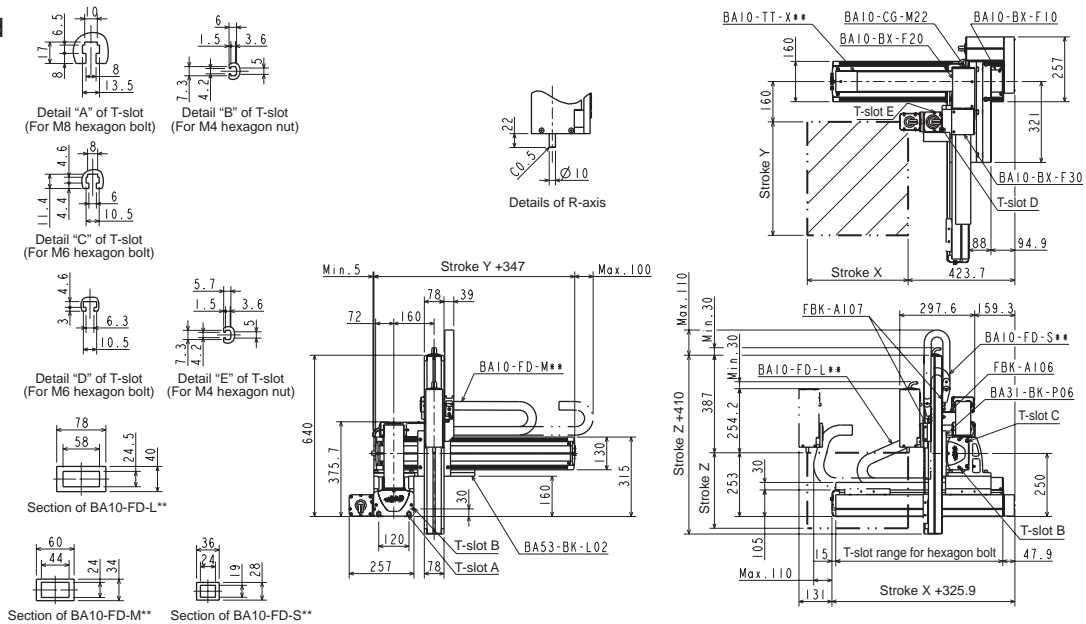

L: Left-handed

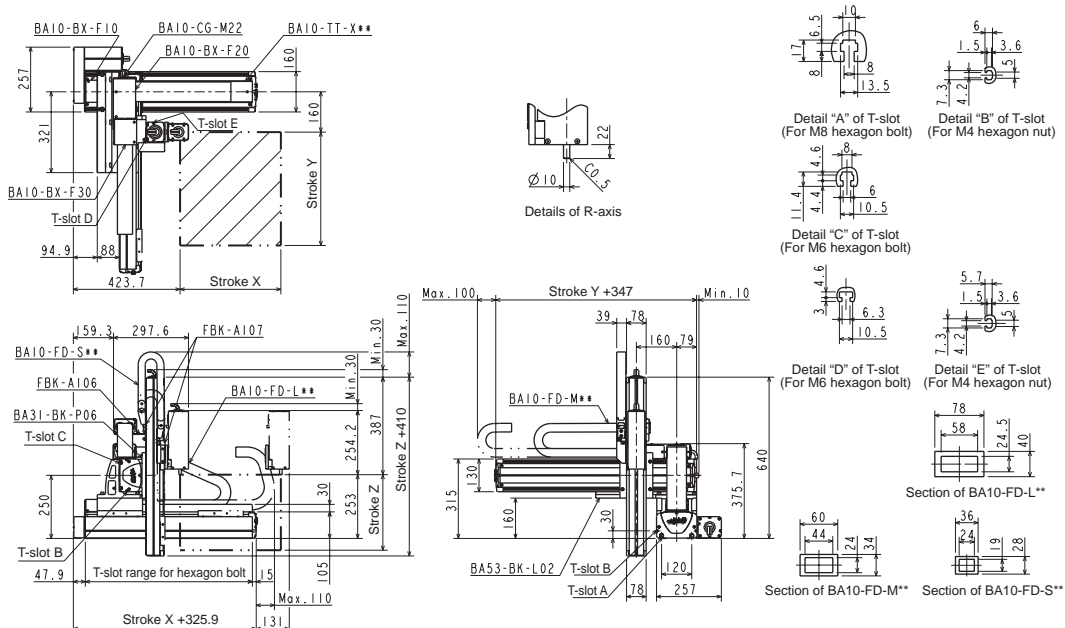

[Set designation]

BA3 - A5 - A4B R A - 40 40 30 - RF 1 3

Combined operation R: Right-handed L: Left-handed	Axis 1 stroke 20 : 200mm 90 : 900mm AO : 1000mm GO : 1600mm	Axis 2 stroke 10 : 100mm 90 : 900mm AO : 1000mm	Axis 3 stroke 10 : 100mm 30 : 300mm	Controller (CA25-M10) 0 : None 1 : NPN output specifications Other : See page 20	Cable length 3 : 3m 9 : 9m 5 : 5m B : 11m 7 : 7m D : 13m
---	---	--	---	---	---

Harmonic drive type

X-axis: Ball screw driven Motor straight
Y-axis: Ball screw driven Motor straight
Z-axis: Ball screw driven Motor straight
R-axis: Harmonic drive

Note 1: When the stroke is as given below, the maximum speed differs.

[Specifications]

	X-axis	Y-axis	Z-axis	R-axis
Type of axis	BE50F-ST-M20N-□0	BE30F-ST-M20N-□0	BE10E-ST-M05B-□0	BE00D-RH-A
Stroke (in increments of 100 mm)	200 ~ 1600mm	100 ~ 1000mm	100 ~ 300mm	360°
Maximum speed	1200mm/s (Note 1)	1200mm/s (Note 1)	300mm/s	360°/s
Positioning repeatability	± 0.01mm	± 0.01mm	± 0.01mm	± 0.025°
Lead of ball screw	20mm	20mm	5mm	1/50 (Reduction ratio)
Motor output	200W	200W	100W, with brake	50W
Resolution	0.01 mm (R-axis: 0.01 deg.)			

Acceleration/deceleration time when the maximum speed is set: 0.36 sec. or over

	Stroke (mm)	Maximum speed (mm/s)
X-axis	700~800	1100
	900~1000	1000
	1100~1200	700
	1300	500
	1400	400
	1500	300
Y-axis	1600	300
	700	1000
	800	800
	900~1000	600

Maximum payload (kg)	Z-axis stroke	Y-axis stroke									
		100mm	200mm	300mm	400mm	500mm	600mm	700mm	800mm	900mm	1000mm
100mm	100mm	5.0	5.0	5.0	5.0	5.0	5.0	5.0	5.0	5.0	3.0
	200mm	5.0	5.0	5.0	5.0	5.0	5.0	5.0	5.0	5.0	2.0
	300mm	5.0	5.0	5.0	5.0	5.0	5.0	5.0	5.0	4.0	1.0

R: Right-handed

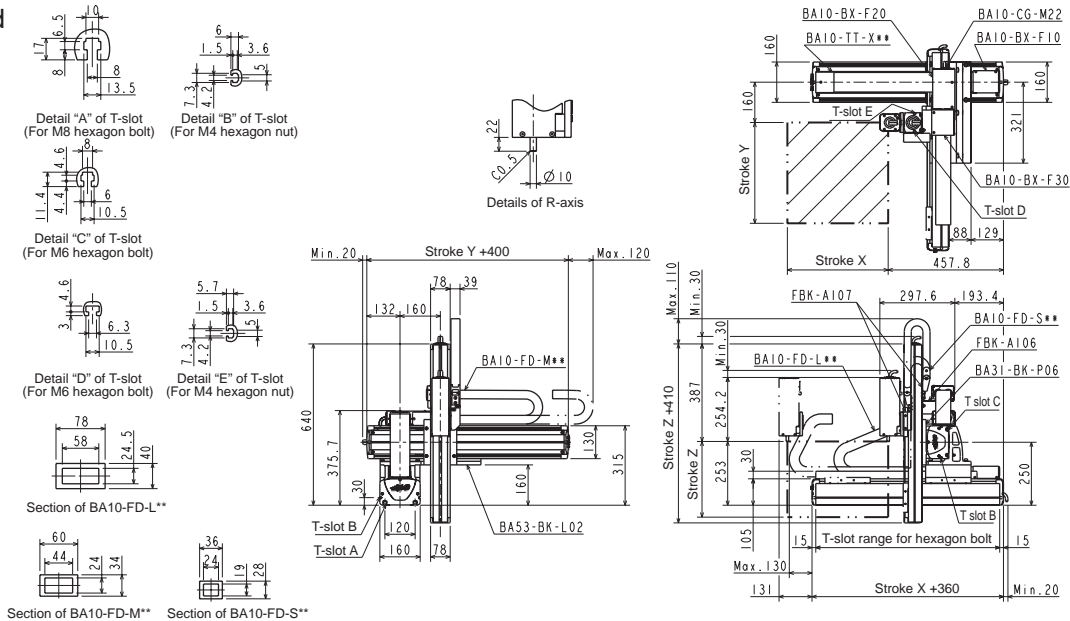

L: Left-handed

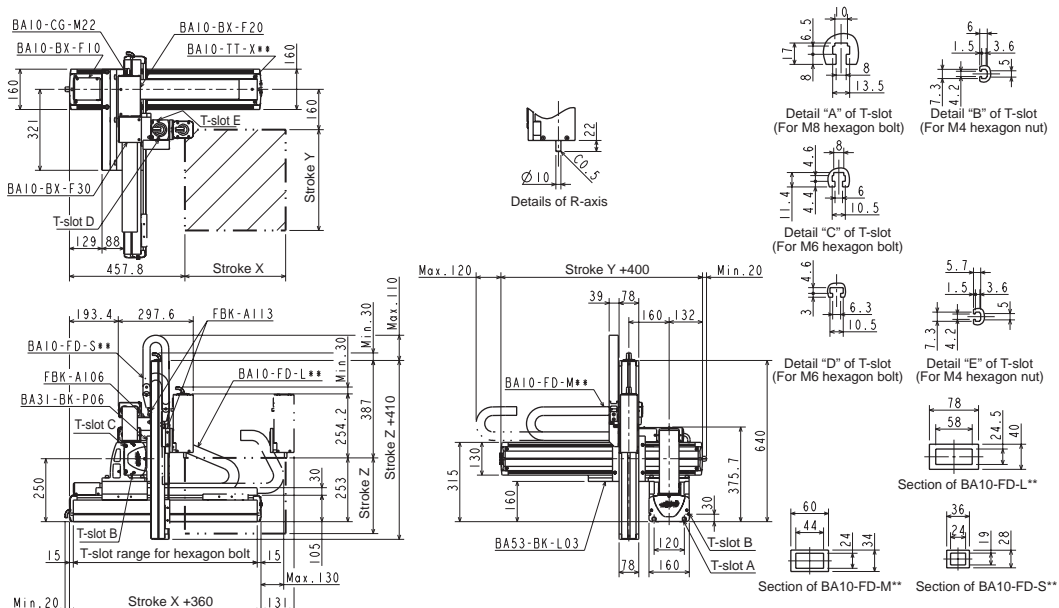

[Set designation]

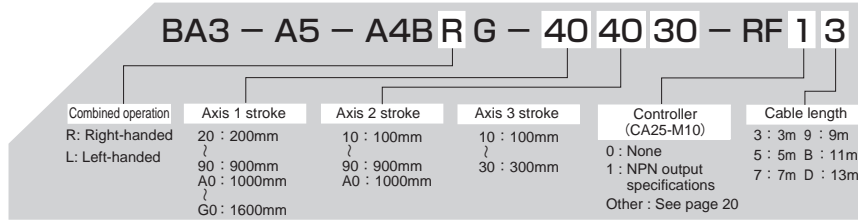

Harmonic drive type

X-axis: Ball screw driven Side mounted motor
Y-axis: Ball screw driven Motor straight
Z-axis: Ball screw driven Motor straight
R-axis: Harmonic drive

Note 1: When the stroke is as given below, the maximum speed differs.

[Specifications]

	X-axis	Y-axis	Z-axis	R-axis
Type of axis	BE50F-U □-M20N- □0	BE30F-ST-M20N- □0	BE10E-ST-M05B- □0	BE00D-RH-A
Stroke (in increments of 100 mm)	200 ~ 1600mm	100 ~ 1000mm	100 ~ 300mm	360°
Maximum speed	1200mm/s (Note 1)	1200mm/s (Note 1)	300mm/s	360°/s
Positioning repeatability	± 0.01mm	± 0.01mm	± 0.01mm	± 0.025°
Lead of ball screw	20mm	20mm	5mm	1/50 (Reduction ratio)
Motor output	200W	200W	100W, with brake	50W
Resolution	0.01mm (R-axis: 0.01 deg.)			

Acceleration/deceleration time when the maximum speed is set: 0.36 sec. or over

	Stroke (mm)	Maximum speed (mm/s)
X-axis	700~800	1100
	900~1000	1000
	1100~1200	700
	1300	500
	1400	400
	1500	300
Y-axis	1600	300
	700	1000
	800~1000	800

Maximum payload (kg)	Z-axis stroke	Y-axis stroke									
		100mm	200mm	300mm	400mm	500mm	600mm	700mm	800mm	900mm	1000mm
100mm	100mm	5.0	5.0	5.0	5.0	5.0	5.0	5.0	5.0	5.0	3.0
	200mm	5.0	5.0	5.0	5.0	5.0	5.0	5.0	5.0	5.0	2.0
	300mm	5.0	5.0	5.0	5.0	5.0	5.0	5.0	5.0	4.0	1.0

R: Right-handed

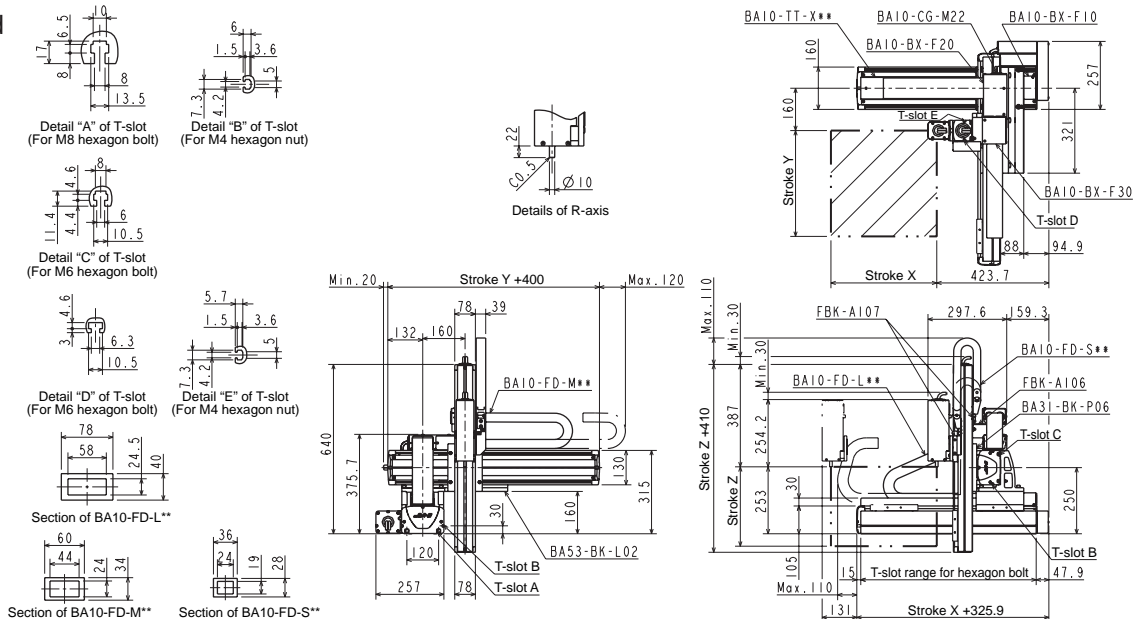

L: Left-handed

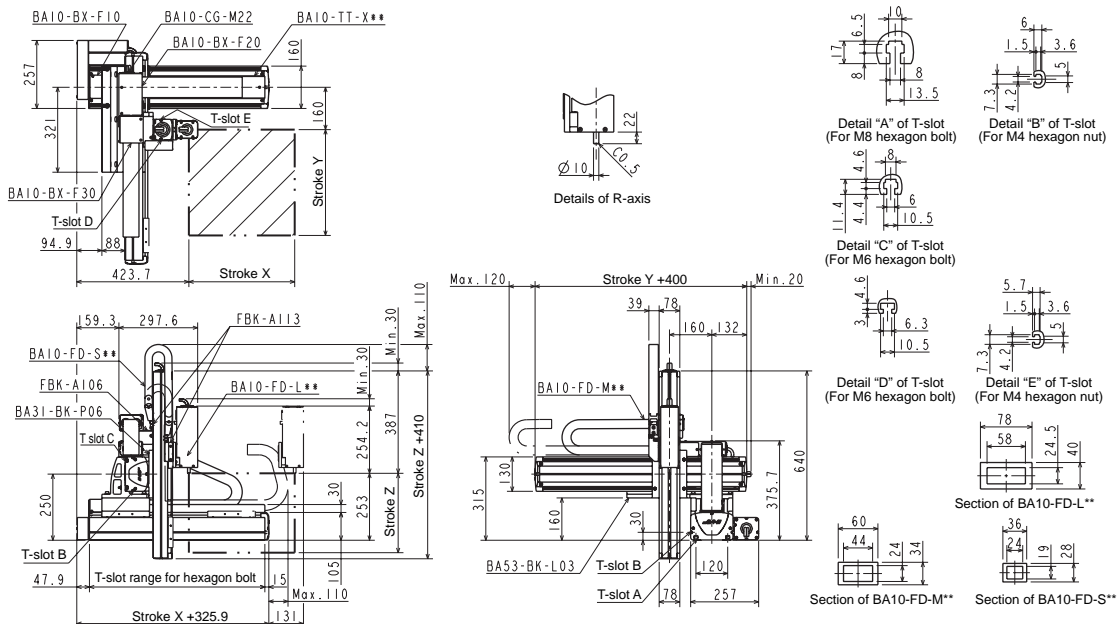

[Set designation]

BA3 - A5 - A4R A - 40 45 30 - UF 1 3

Combined operation R: Right-handed L: Left-handed	Axis 1 stroke 20 : 200mm λ 90 : 900mm A0 : 1000mm λ G0 : 1600mm	Axis 2 stroke 15 : 150mm λ 95 : 950mm A5 : 1050mm	Axis 3 stroke 10 : 100mm λ 30 : 300mm	Controller (CA25-M10) 0 : None 1 : NPN output specifications Other : See page 20	Cable length 3 : 3m 9 : 9m 5 : 5m B : 11m 7 : 7m D : 13m
---	---	---	--	---	---

Planet gear type

X-axis: Ball screw driven Motor straight
Y-axis: Ball screw driven Motor straight
Z-axis: Ball screw driven Motor straight
R-axis: Planet gear

Note 1: When the stroke is as given below, the maximum speed differs.

[Specifications]

	X-axis	Y-axis	Z-axis	R-axis
Type of axis	BE50F-ST-M20N-□0	BE30E-ST-M20N-□5	BE10E-ST-M05B-□0	BE00D-RP-A
Stroke (in increments of 100 mm)	200 ~ 1600mm	150 ~ 1050mm	100 ~ 300mm	360°
Maximum speed	1200mm/s (Note 1)	1200mm/s (Note 1)	300mm/s	857°/s
Positioning repeatability	± 0.01mm	± 0.01mm	± 0.01mm	± 0.125°
Lead of ball screw	20mm	20mm	5mm	1/21 (Reduction ratio)
Motor output	200W	100W	100W, with brake	50W
Resolution	0.01 mm (R-axis: 0.01 deg.)			

Acceleration/deceleration time when the maximum speed is set: 0.36 sec. or over

	Stroke (mm)	Maximum speed (mm/s)
X-axis	700~800	1100
	900~1000	1000
	1100~1200	700
	1300	500
	1400	400
	1500	300
Y-axis	1600	300
	750	1000
	850	800
	950~1050	600

Maximum payload (kg)	Z-axis stroke	Y-axis stroke									
		150mm	250mm	350mm	450mm	550mm	650mm	750mm	850mm	950mm	1050mm
100mm	100mm	8.0	8.0	8.0	8.0	8.0	8.0	8.0	7.0	5.0	3.0
	200mm	6.0	6.0	6.0	6.0	6.0	6.0	6.0	6.0	4.0	2.0
	300mm	5.0	5.0	5.0	5.0	5.0	5.0	5.0	5.0	4.0	1.0

R: Right-handed

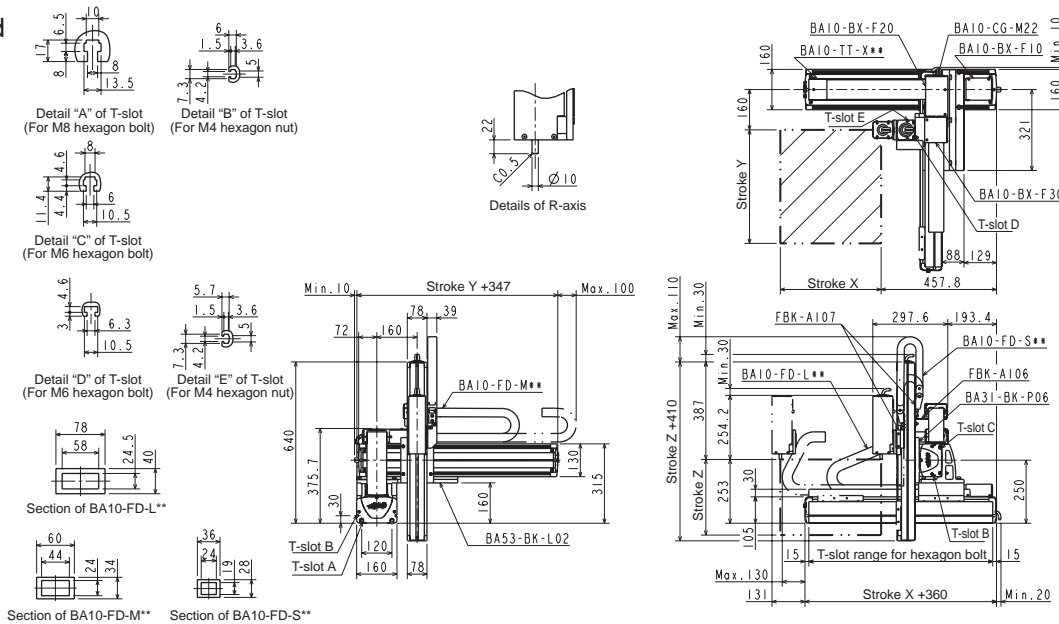

L: Left-handed

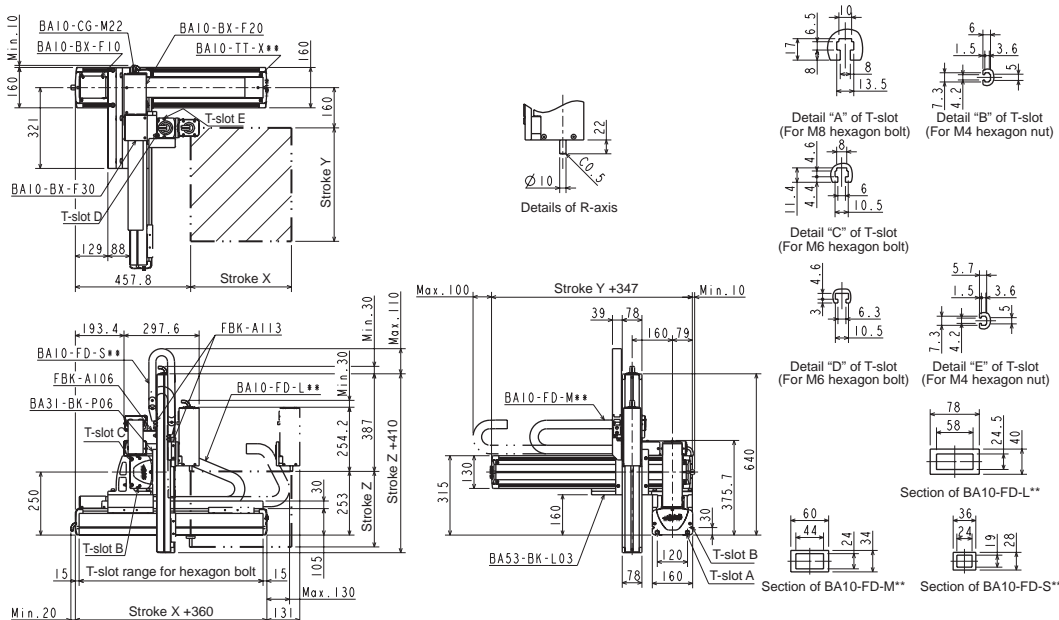

[Set designation]

BA3 – A5 – A4AR G – 40 45 30 – UF 1 3

Combined operation	Axis 1 stroke	Axis 2 stroke	Axis 3 stroke	Controller (CA25-M10)	Cable length
R: Right-handed	20 : 200mm	15 : 150mm	10 : 100mm	0 : None	3 : 3m 9 : 9m
L: Left-handed	90 : 900mm A0 : 1000mm G0 : 1600mm	95 : 950mm A5 : 1050mm	30 : 300mm	1 : NPN output specifications Other : See page 20	5 : 5m B : 11m 7 : 7m D : 13m

Planet gear type

- X-axis: Ball screw driven Side mounted motor
- Y-axis: Ball screw driven Motor straight
- Z-axis: Ball screw driven Motor straight
- R-axis: Planet gear

Note 1: When the stroke is as given below, the maximum speed differs.

[Specifications]

	X-axis	Y-axis	Z-axis	R-axis
Type of axis	BE50F-U □-M20N-□0	BE30E-ST-M20N-□5	BE10E-ST-M05B-□0	BE00D-RP-A
Stroke (in increments of 100 mm)	200 ~ 1600mm	150 ~ 1050mm	100 ~ 300mm	360°
Maximum speed	1200mm/s (Note 1)	1200mm/s (Note 1)	300mm/s	857°/s
Positioning repeatability	± 0.01mm	± 0.01mm	± 0.01mm	± 0.125°
Lead of ball screw	20mm	20mm	5mm	1/21 (Reduction ratio)
Motor output	200W	100W	100W, with brake	50W
Resolution	0.01 mm (R-axis: 0.01 deg.)			

Acceleration/deceleration time when the maximum speed is set: 0.36 sec. or over

	Stroke (mm)	Maximum speed (mm/s)
X-axis	700~800	1100
	900~1000	1000
	1100~1200	700
	1300	500
	1400	400
	1500	300
Y-axis	1600	300
	750	1000
	850	800
	950~1050	600

Maximum payload (kg)	Z-axis stroke	Y-axis stroke									
		150mm	250mm	350mm	450mm	550mm	650mm	750mm	850mm	950mm	1050mm
100mm	100mm	8.0	8.0	8.0	8.0	8.0	8.0	8.0	7.0	5.0	3.0
	200mm	6.0	6.0	6.0	6.0	6.0	6.0	6.0	6.0	4.0	2.0
	300mm	5.0	5.0	5.0	5.0	5.0	5.0	5.0	5.0	4.0	1.0

R: Right-handed

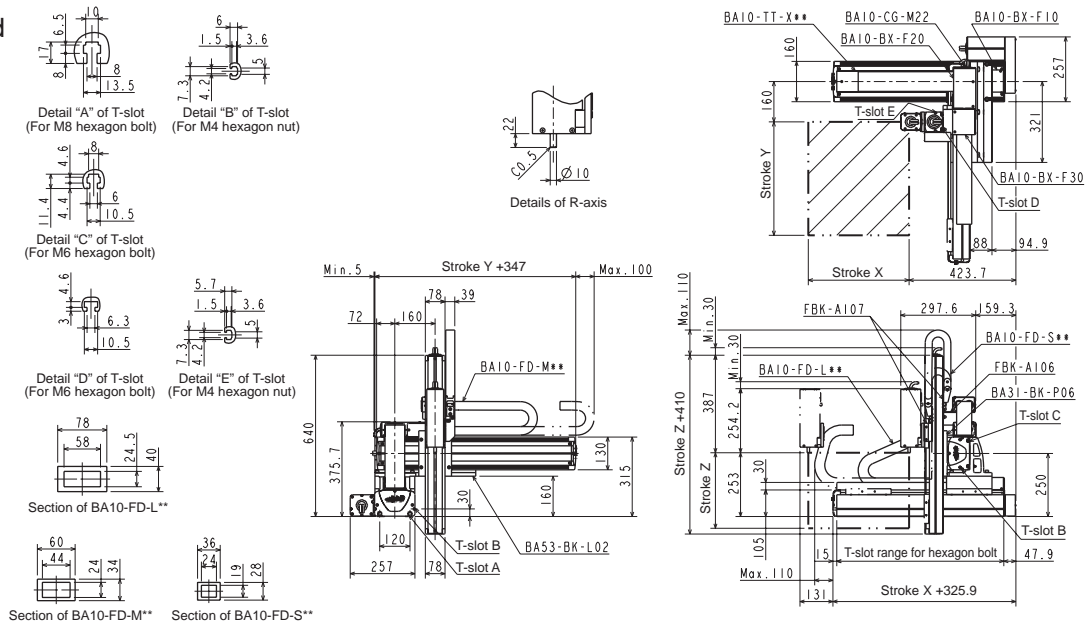

L: Left-handed

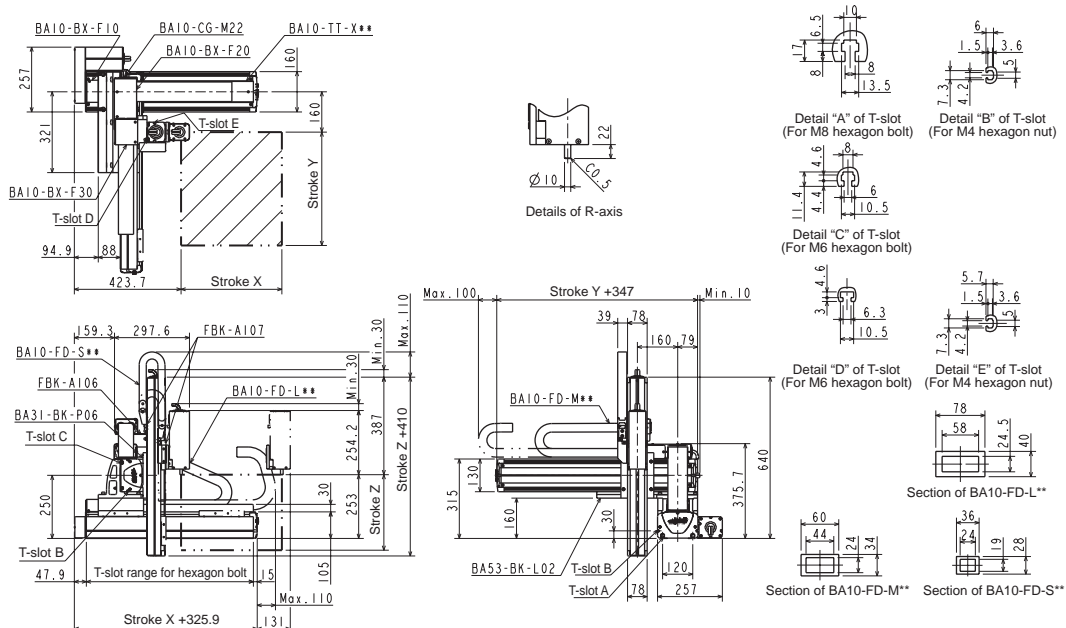

[Set designation]

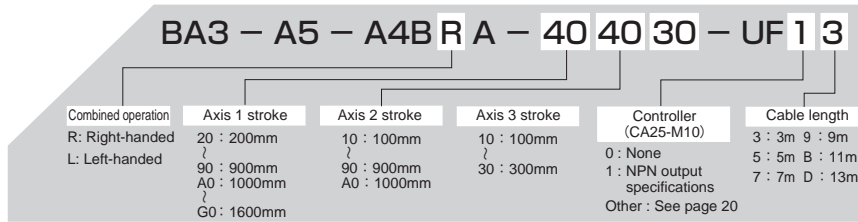

Planet gear type

X-axis: Ball screw driven Motor straight
Y-axis: Ball screw driven Motor straight
Z-axis: Ball screw driven Motor straight
R-axis: Planet gear

Note 1: When the stroke is as given below, the maximum speed differs.

[Specifications]

	X-axis	Y-axis	Z-axis	R-axis
Type of axis	BE50F-ST-M20N-□0	BE30F-ST-M20N-□0	BE10E-ST-M05B-□0	BE00D-RP-A
Stroke (in increments of 100 mm)	200 ~ 1600mm	100 ~ 1000mm	100 ~ 300mm	360°
Maximum speed	1200mm/s (Note 1)	1200mm/s (Note 1)	300mm/s	857°/s
Positioning repeatability	± 0.01mm	± 0.01mm	± 0.01mm	± 0.125°
Lead of ball screw	20mm	20mm	5mm	1/21 (Reduction ratio)
Motor output	200W	200W	100W, with brake	50W
Resolution	0.01mm (R-axis: 0.01 deg.)			

Acceleration/deceleration time when the maximum speed is set: 0.36 sec. or over

	Stroke (mm)	Maximum speed (mm/s)
X-axis	700~800	1100
	900~1000	1000
	1100~1200	700
	1300	500
	1400	400
	1500	300
	1600	300
Y-axis	700	1000
	800	800
	900~1000	600

Maximum payload (kg)	Z-axis stroke	Y-axis stroke									
		100mm	200mm	300mm	400mm	500mm	600mm	700mm	800mm	900mm	1000mm
100mm	100mm	10.0	10.0	10.0	10.0	10.0	10.0	10.0	8.0	5.0	3.0
	200mm	10.0	10.0	10.0	10.0	10.0	10.0	10.0	7.0	5.0	2.0
	300mm	10.0	10.0	10.0	10.0	10.0	10.0	10.0	7.0	4.0	2.0

R: Right-handed

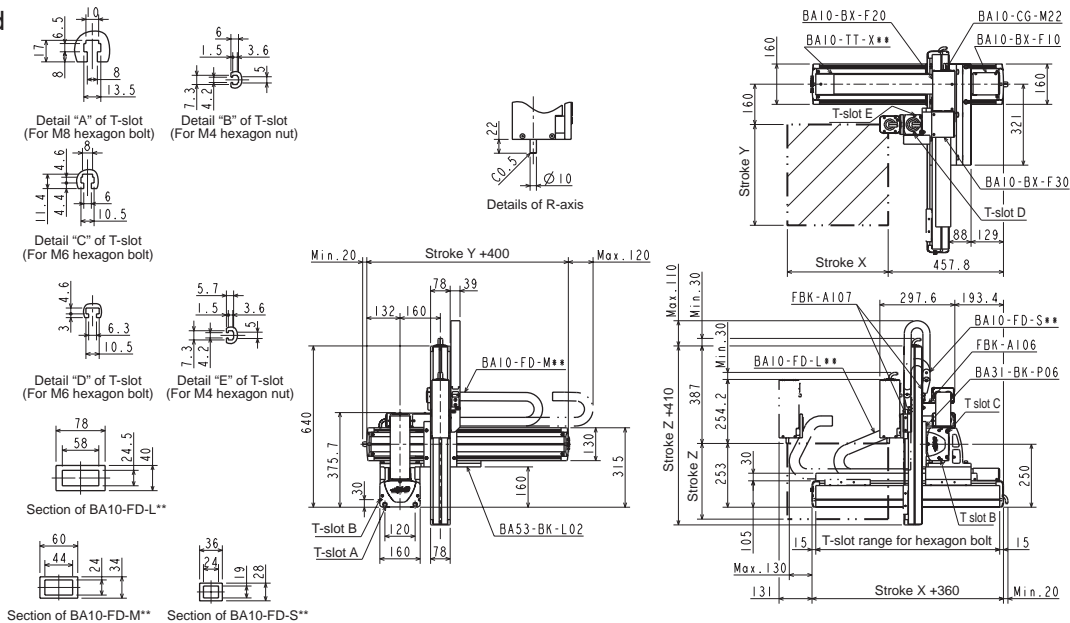

L: Left-handed

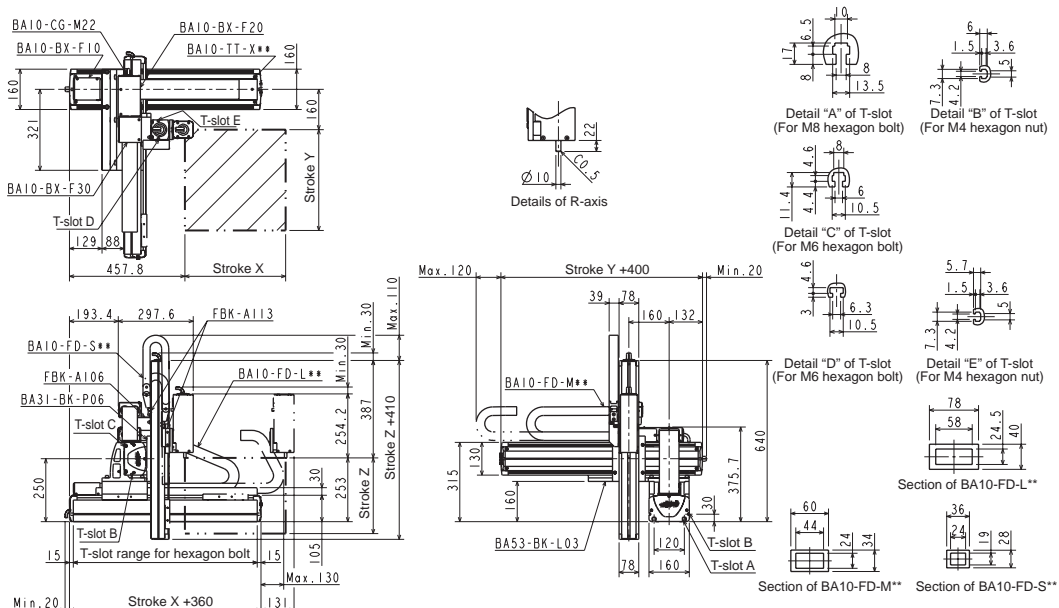

[Set designation]

BA3 - A5 - A4B R G - 40 40 30 - UF 1 3

Combined operation	Axis 1 stroke	Axis 2 stroke	Axis 3 stroke	Controller (CA25-M10)	Cable length
R: Right-handed	20 : 200mm	10 : 100mm	10 : 100mm	0: None	3 : 3m 9 : 9m
L: Left-handed	90 : 900mm A0 : 1000mm G0 : 1600mm	90 : 900mm A0 : 1000mm	30 : 300mm	1: NPN output specifications Other : See page 20	5 : 5m B : 11m 7 : 7m D : 13m

Planet gear type

- X-axis: Ball screw driven Side mounted motor
- Y-axis: Ball screw driven Motor straight
- Z-axis: Ball screw driven Motor straight
- R-axis: Planet gear

Note 1: When the stroke is as given below, the maximum speed differs.

[Specifications]

	X-axis	Y-axis	Z-axis	R-axis
Type of axis	BE50F-U □-M20N- □0	BE30F-ST-M20N- □0	BE10E-ST-M05B- □0	BE00D-RP-A
Stroke (in increments of 100 mm)	200 ~ 1600mm	100 ~ 1000mm	100 ~ 300mm	360°
Maximum speed	1200mm/s (Note 1)	1200mm/s (Note 1)	300mm/s	857°/s
Positioning repeatability	± 0.01mm	± 0.01mm	± 0.01mm	± 0.125°
Lead of ball screw	20mm	20mm	5mm	1/21 (Reduction ratio)
Motor output	200W	200W	100W, with brake	50W
Resolution	0.01mm (R-axis: 0.01 deg.)			

Acceleration/deceleration time when the maximum speed is set: 0.36 sec. or over

	Stroke (mm)	Maximum speed (mm/s)
X-axis	700~800	1100
	900~1000	1000
	1100~1200	700
	1300	500
	1400	400
	1500	300
Y-axis	1600	300
	700	1000
	800	800
	900~1000	600

Maximum payload (kg)	Z-axis stroke	Y-axis stroke									
		100mm	200mm	300mm	400mm	500mm	600mm	700mm	800mm	900mm	1000mm
100mm	100mm	10.0	10.0	10.0	10.0	10.0	10.0	10.0	8.0	5.0	3.0
	200mm	10.0	10.0	10.0	10.0	10.0	10.0	10.0	7.0	5.0	2.0
	300mm	10.0	10.0	10.0	10.0	10.0	10.0	10.0	7.0	4.0	2.0

R: Right-handed

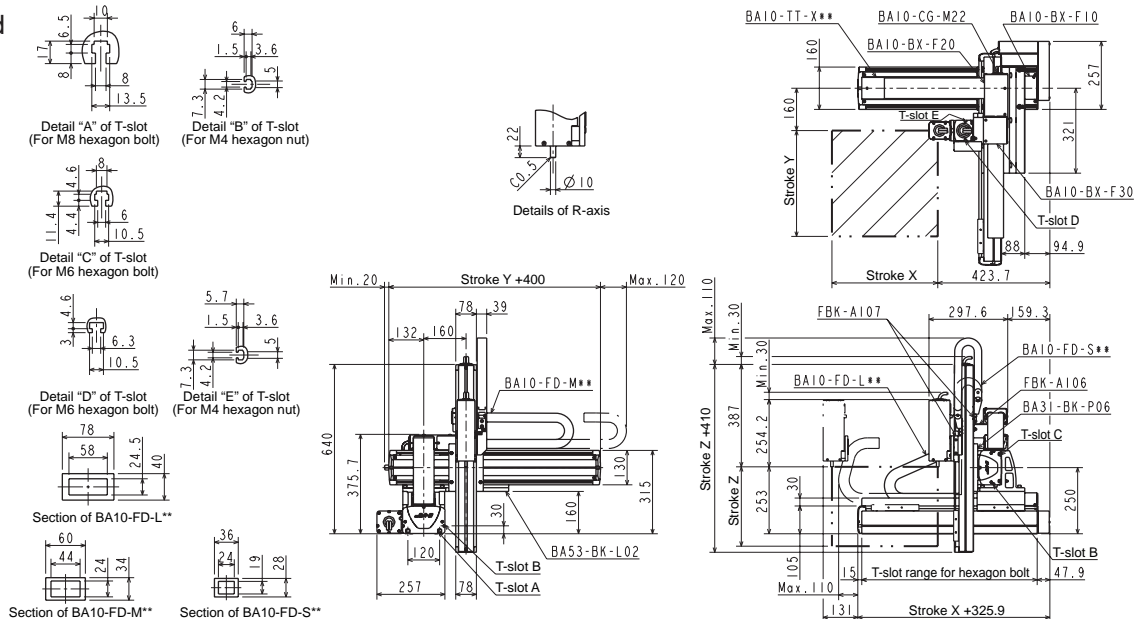

L: Left-handed

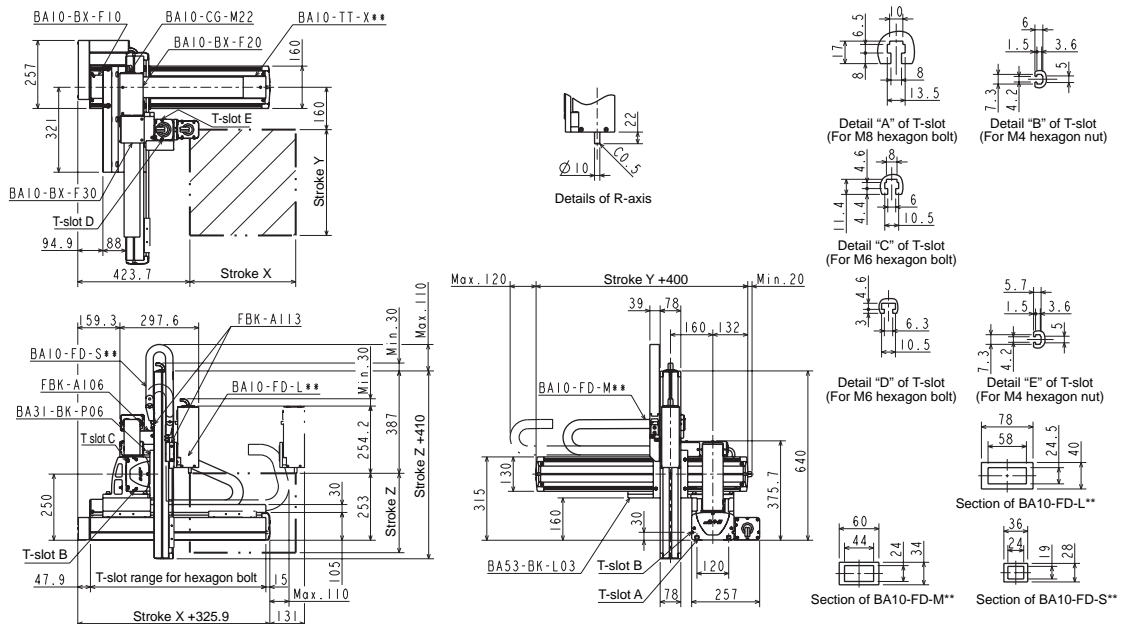

Axis-Related Components

Components

Axis Combination Bracket	144
Controller Cable	152
CN Box	152
CN Box Wrench	155
Flexible Tube	156
Flexible Duc	157
Tube Tray	158
Flexible Tray	158

Options

Support Guide.....	159
Home Position Change Sensor	161
Strain Relief	161
Cable Grip	162

Axis Combination Bracket

[Application]

Brackets are used to combine axes (or actuators) in a Cartesian form. A large number of brackets are available to cope with various combinations. Bolts and nuts are attached.

[Code designation]

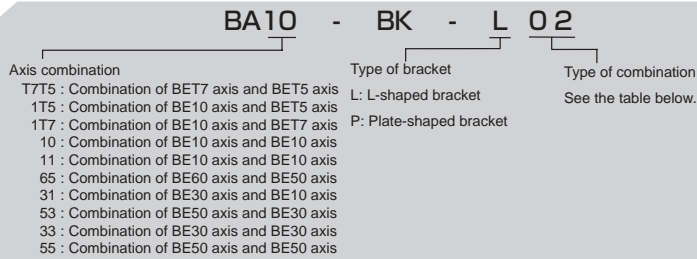

[Type of brackets by axis combination]

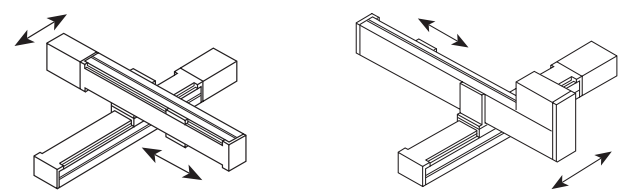
Axis combination [1]	Basic axis	Axis 2	Type of bracket	Ref. Page
 <p>X-Y Right-handed Y-axis slider opposite to motor side</p> <p>X-Y Left-handed Y-axis slider on motor side</p>	BET7	BET5	BAT7T5-BK-L02	P146
	BE10	BET7	BA1T7-BK-L02	P146
	BE10	BET5	BA1T5-BK-L02	P146
	BE10	BE10	BA10-BK-L02	P146
	BE30	BE10	BA31-BK-L02	P146
	BE50	BE30	BA53-BK-L02	P146
	BE30	BE30	BA33-BK-L02	P147
	BE50	BE50	BA55-BK-L02	P147
	BE60	BE50	BA65-BK-L02	P151

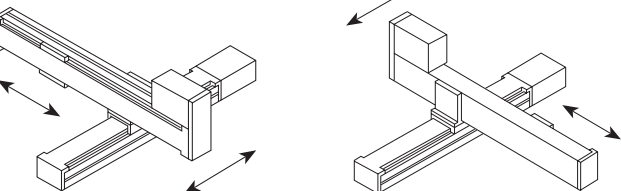
Axis combination [2]	Basic axis	Axis 2	Type of bracket	Ref. Page
 <p>X-Y Left-handed Y-axis slider opposite to motor side</p> <p>X-Y Right-handed Y-axis slider on motor side</p>	BET7	BET5	BAT7T5-BK-L03	P147
	BE10	BET7	BA1T7-BK-L03	P147
	BE10	BET5	BA1T5-BK-L03	P147
	BE10	BE10	BA10-BK-L03	P147
	BE30	BE10	BA31-BK-L03	P148
	BE50	BE30	BA53-BK-L03	P148
	BE30	BE30	BA33-BK-L03	P148
	BE50	BE50	BA55-BK-L03	P148
	BE60	BE50	BA65-BK-L03	P151

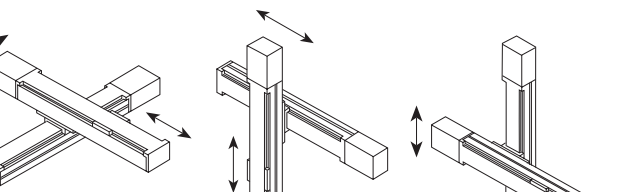
Axis combination [3]	Basic axis	Axis 2	Type of bracket	Ref. Page
 <p>X-Y table</p> <p>Y-Z</p> <p>Z-Y</p>	BET7	BET5	BAT7T5-BK-P06	P148
	BE10	BET7	BA1T7-BK-P06	P148
	BE10	BET7	BA1T7-BK-P06S	P149
	BE10	BET5	BA1T5-BK-P06	P149
	BE10	BE10	BA10-BK-P06	P149
	BE30	BE10	BA31-BK-P06	P149
	BE50	BE30	BA53-BK-P06	P149

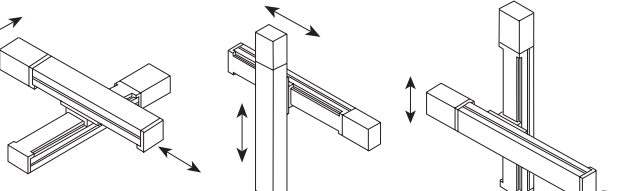
Axis combination [4]	Basic axis	Axis 2	Type of bracket	Ref. Page
 <p>X-Y (moving-axis) Table</p> <p>Y-Z (moving-axis)</p> <p>Z-Y (moving-axis)</p>	BE10	BE10	BA10-BK-P07	P149
	BE30	BE10	BA31-BK-P07	P150
	BE50	BE30	BA53-BK-P07	P150

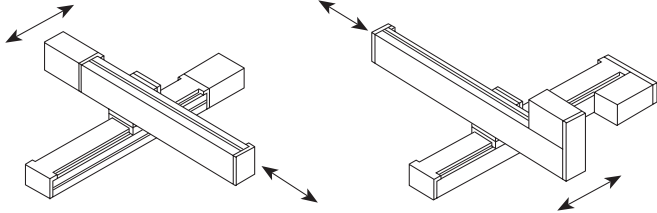
Axis combination [5]	Basic axis	Axis 2	Type of bracket	Ref. Page
 <p>X-Y (moving-axis) Right-handed</p> <p>X-Y (moving-axis) Left-handed</p>	BE10	BE10	BA10-BK-L04	P150

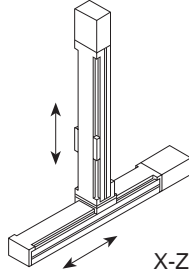
Axis combination [6]	Basic axis	Axis 2	Type of bracket	Ref. Page
 <p>X-Z</p>	BE10	BE10	BA11-BK-L01	P150
	BE30	BE10	BA31-BK-L01	P150
	BE50	BE30	BA53-BK-L01	P150
	BE30	BE30	BA33-BK-L01	P151
	BE50	BE50	BA55-BK-L01	P151

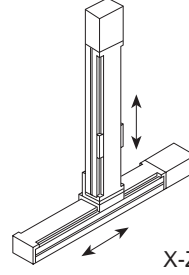
Axis combination [7]	Basic axis	Axis 2	Type of bracket	Ref. Page
 <p>X-Z Z-axis facing sideways</p>	BE10	BE10	BA10-BK-L05	P151

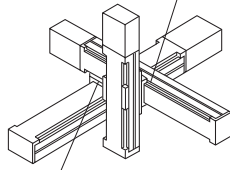
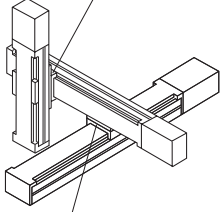
Axis combination [8]				
 <p>See Axis combination [3] Y-Z.</p> <p>See Axis combination [1] X-Y.</p> <p>X-Y-Z Right-handed Y-axis slider opposite to motor side</p>				
 <p>See Axis combination [3] Y-Z.</p> <p>See Axis combination [2] X-Y.</p> <p>X-Y-Z Left-handed Y-axis slider opposite to motor side</p>				

Dimensions of Axis Combination Bracket

[BA33-BK-L02] Material: Aluminum alloy, mass 5.9 kg

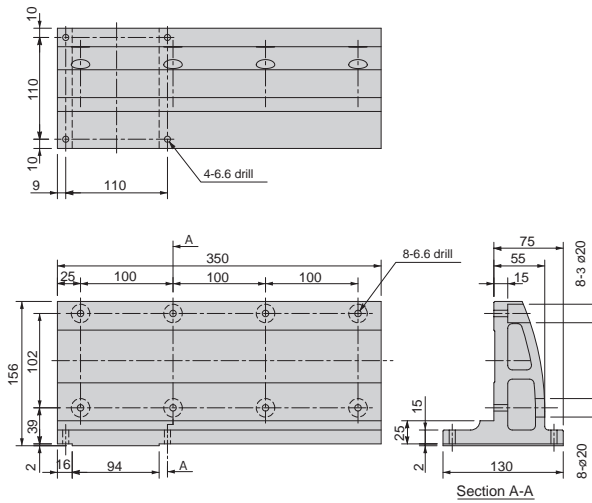

[BA55-BK-L02] Material: Aluminum alloy, mass 10 kg

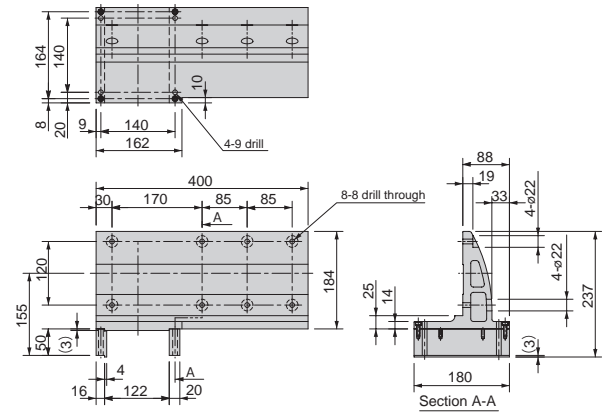

[BAT7T5-BK-L03] Material: Aluminum alloy, mass 0.5 kg

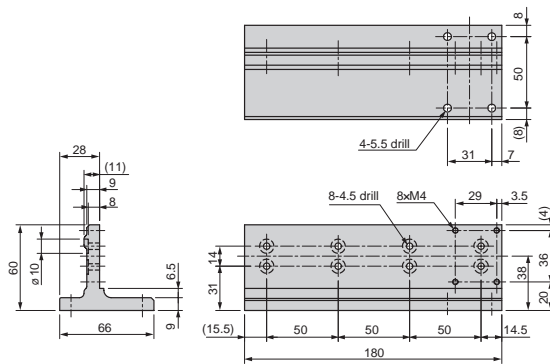

[BA1T7-BK-L03] Material: Aluminum alloy, mass 0.8 kg

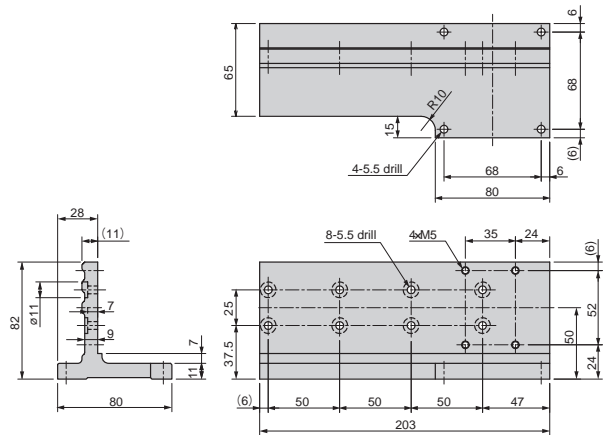

[BA1T5-BK-L03] Material: Aluminum alloy, mass 0.8 kg

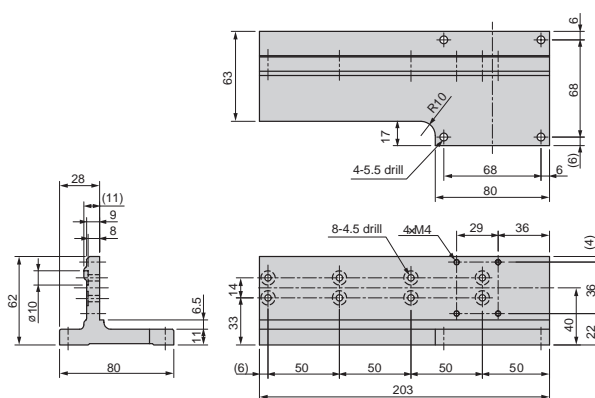

[BA10-BK-L03] Material: Aluminum alloy, mass 0.9 kg

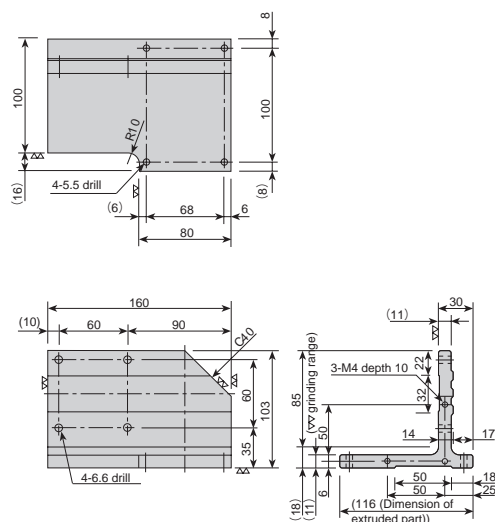

Dimensions of Axis Combination Bracket

[BA31-BK-L03] Material: Aluminum alloy, mass 1.9 kg

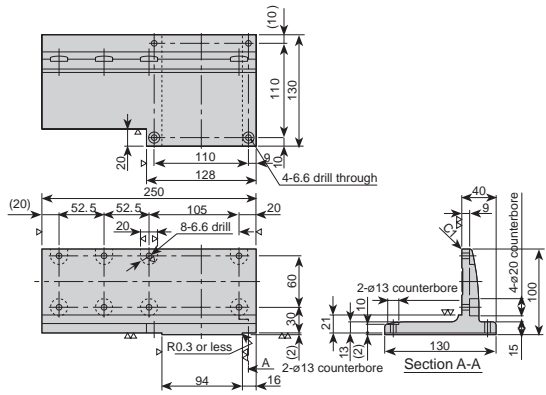

[BA53-BK-L03] Material: Aluminum alloy, mass 8.5 kg

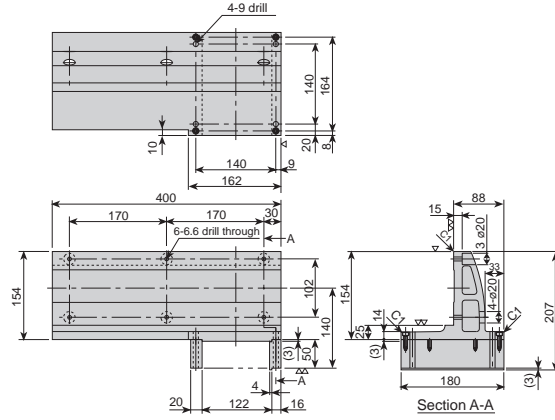

[BA33-BK-L03] Material: Aluminum alloy, mass 5.9 kg

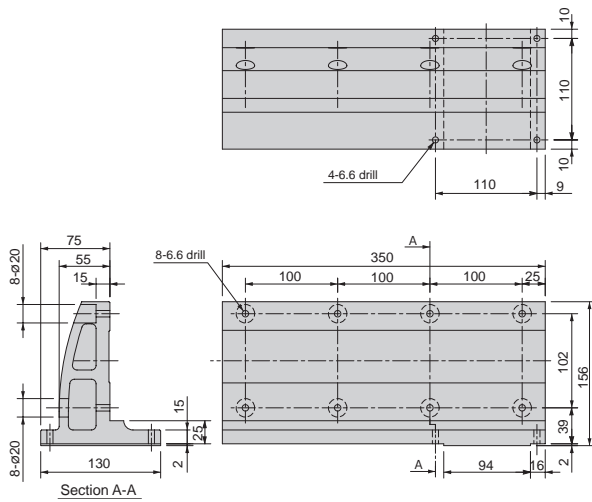

[BA55-BK-L03] Material: Aluminum alloy, mass 10 kg

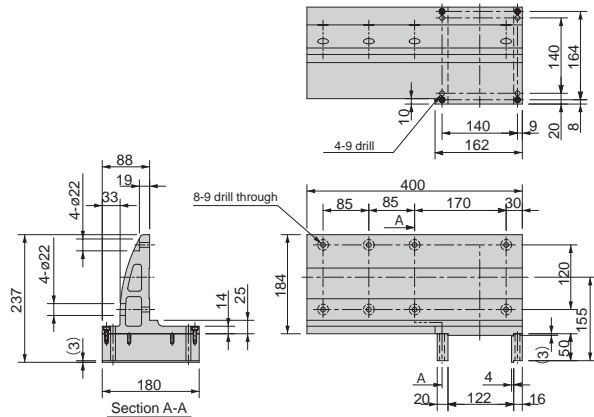

[BAT7T5-BK-P06]]Material: Aluminum alloy, mass 0.3 kg

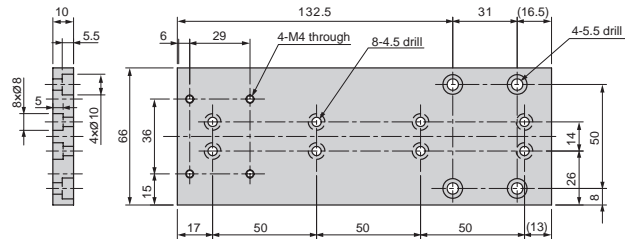

[BA1T7-BK-P06] Material: Aluminum alloy, mass 0.5 kg

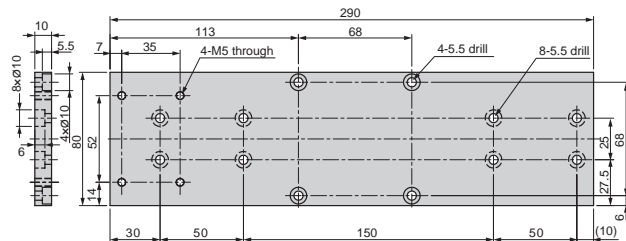

* Stroke of axis 2: For 150 mm or over

Dimensions of Axis Combination Bracket

[BA1T7-BK-P06S]Material: Aluminum alloy, mass 0.5 kg

Technical drawing of bracket [BA1T7-BK-P06S]. The drawing includes a front view, a side view, and a detail of the mounting hole. The front view shows a rectangular plate with a total width of 240 mm and a total height of 68 mm. It features four M5 through holes and four 4-5.5 drill holes. The side view shows a thickness of 10 mm. The detail shows a hole with a diameter of 4 mm and a depth of 10 mm.

[BA1T5-BK-P06]Material: Aluminum alloy, mass 0.5 kg

Technical drawing of bracket [BA1T5-BK-P06]. The drawing includes a front view, a side view, and a detail of the mounting hole. The front view shows a rectangular plate with a total width of 180 mm and a total height of 68 mm. It features four M4 through holes and four 4-5.5 drill holes. The side view shows a thickness of 10 mm. The detail shows a hole with a diameter of 4 mm and a depth of 10 mm.

* Stroke of axis 2: For 100 mm or less

[BA10-BK-P06]Material: Aluminum alloy, mass 0.6 kg

Technical drawing of bracket [BA10-BK-P06]. The drawing includes a front view, a side view, and a detail of the mounting hole. The front view shows a rectangular plate with a total width of 130 mm and a total height of 68 mm. It features four M4 holes with a depth of 8 mm, four 4-6.6 drill through holes, and four 4-5.5 drill through holes. The side view shows a thickness of 10 mm. The detail shows a hole with a diameter of 4 mm and a depth of 10 mm.

[BA31-BK-P06]Material: Aluminum alloy, mass 0.9 kg

Technical drawing of bracket [BA31-BK-P06]. The drawing includes a front view, a side view, and a detail of the mounting hole. The front view shows a rectangular plate with a total width of 180 mm and a total height of 130 mm. It features four M6 holes and four 4-16 holes. The side view shows a thickness of 10 mm. The detail shows a hole with a diameter of 4 mm and a depth of 10 mm.

[BA53-BK-P06]Material: Aluminum alloy, mass 1.5 kg

Technical drawing of bracket [BA53-BK-P06]. The drawing includes a front view, a side view, and a detail of the mounting hole. The front view shows a rectangular plate with a total width of 210 mm and a total height of 180 mm. It features four M9 holes and four 4-16 holes. The side view shows a thickness of 10 mm. The detail shows a hole with a diameter of 4 mm and a depth of 10 mm.

[BA10-BK-P07]Material: Aluminum alloy, mass 0.5 kg

Technical drawing of bracket [BA10-BK-P07]. The drawing includes a front view, a side view, and a detail of the mounting hole. The front view shows a rectangular plate with a total width of 116 mm and a total height of 68 mm. It features four 4-5.5 drill through holes and four 4-5.5 drill through holes. The side view shows a thickness of 10 mm. The detail shows a hole with a diameter of 4 mm and a depth of 10 mm.

Dimensions of Axis Combination Bracket

[BA31-BK-P07] Material: Aluminum alloy, mass 0.7 kg

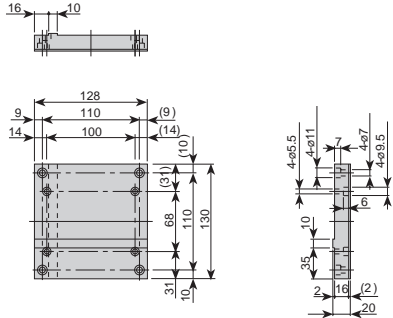

[BA53-BK-P07] Material: Aluminum alloy, mass 1.3 kg

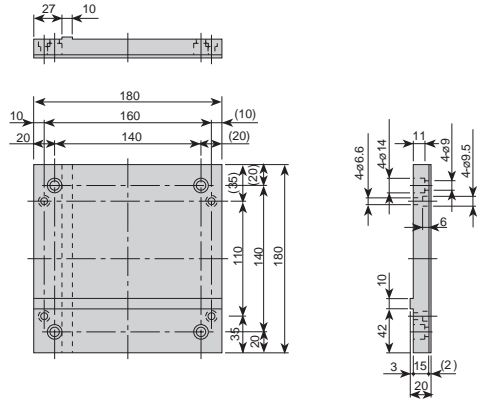

[BA10-BK-L04] Material: Aluminum alloy, mass 0.7 kg

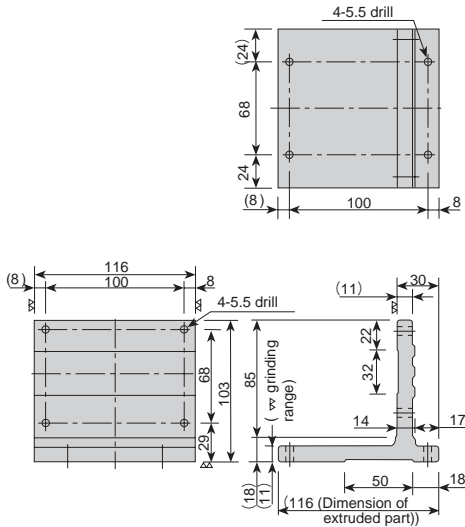

[BA11-BK-L01] Material: Aluminum alloy, mass 1.8 kg

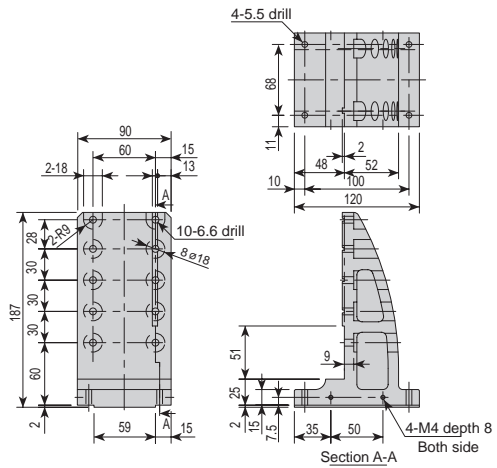

[BA31-BK-L01] Material: Aluminum alloy, mass 2.1 kg

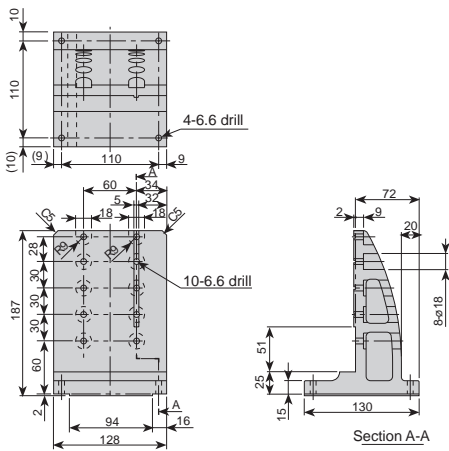

[BA53-BK-L01] Material: Aluminum alloy, mass 4.5 kg

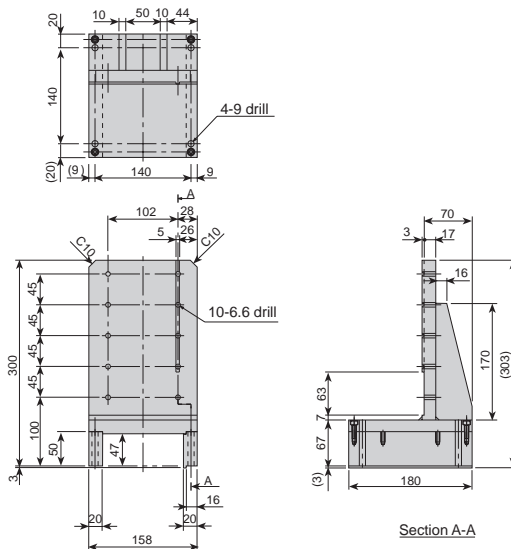

Controller Cable

[Application]

Used to connect a controller with an actuator (or axis). The controller cable consists of motor and encoder signal cables (i.e., two flexible cables).
 When used for a Cartesian two axes system, the cable for the axis 2 should be 2 m longer than that of the axis 1 generally.
 This cable is exclusively used for the actuator, and no user's cable is included.

[Code designation]

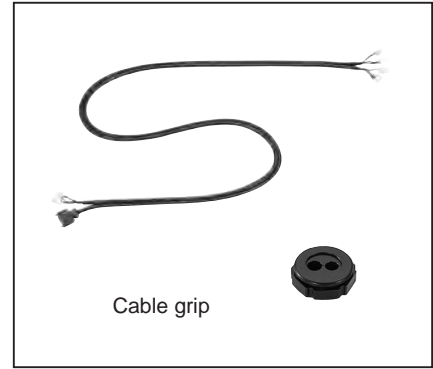
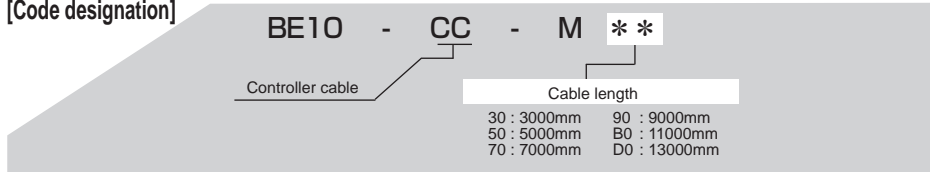

- * The controller cable is supplied as a pair of one each of motor cable and encoder signal cable. A cable grip for these two cables is attached.
- * When using the controller cable for the Cartesian two axes system, pass the cable for the axis 2 through a flexible tube or flexible duct (which is available for an extra price).
- * For the cable length of any special axis combination, consult with us each time.

[Dimensions]

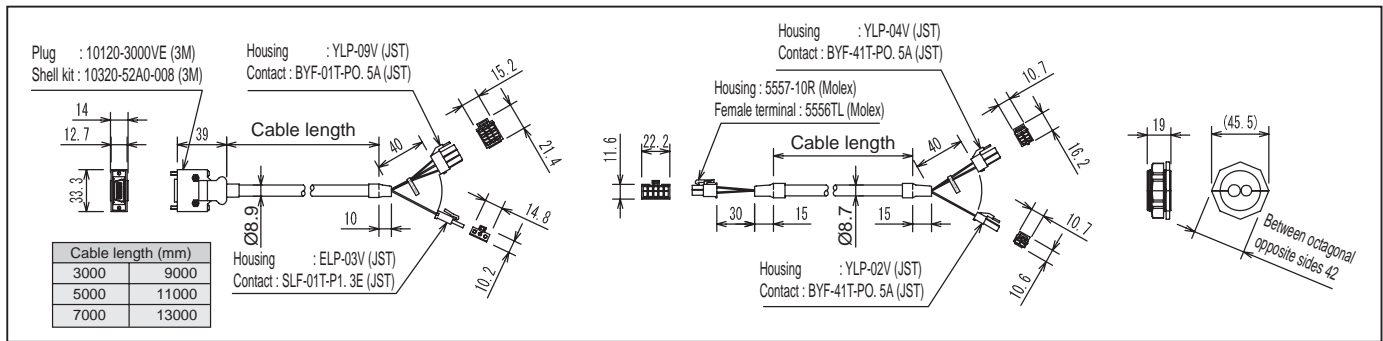

CN Box

[Application]

Used to secure the both ends of a flexible tube or flexible duct.
 A CN box is mounted by using a T-slot on the side of the actuator, on top of the frame cover or on the motor cover.
 The CN box can also be mounted on user's equipment.
 For a single axis system, this box may not be required.

[Code designation]

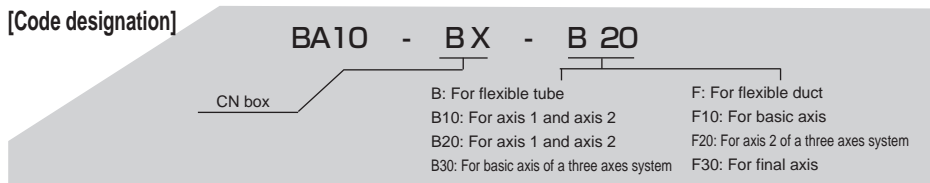

- * A CN box is supplied with a set of caps, metal fixtures, grommets, cable securing fixtures.
- * A controller cable only passes through the box and is connected by means of connectors.
- * Order CN box in quantity of 1 piece and up.

[Dimensions]

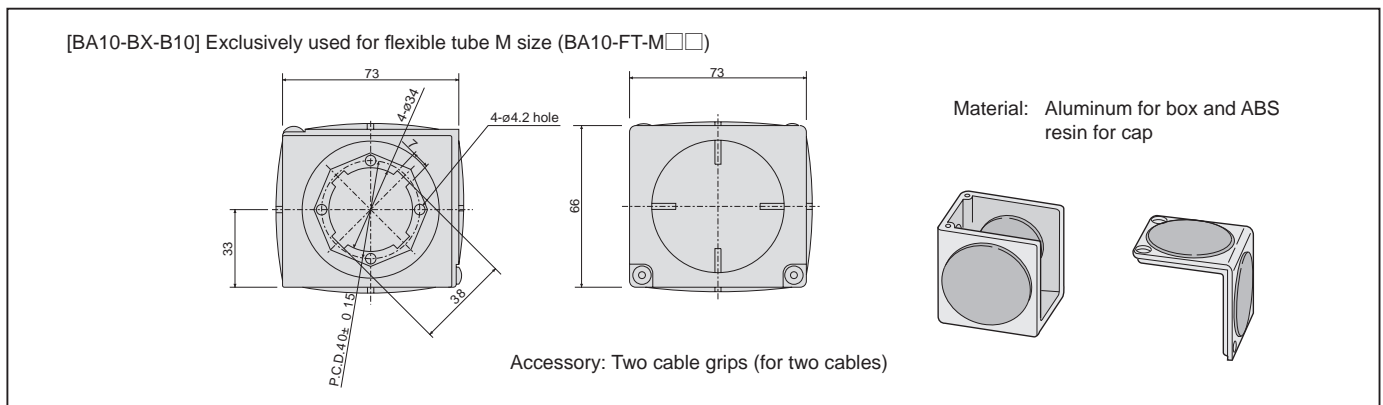

[BA10-BX-B20] Exclusively used for flexible tube L size (BA10-FT-L □ □)

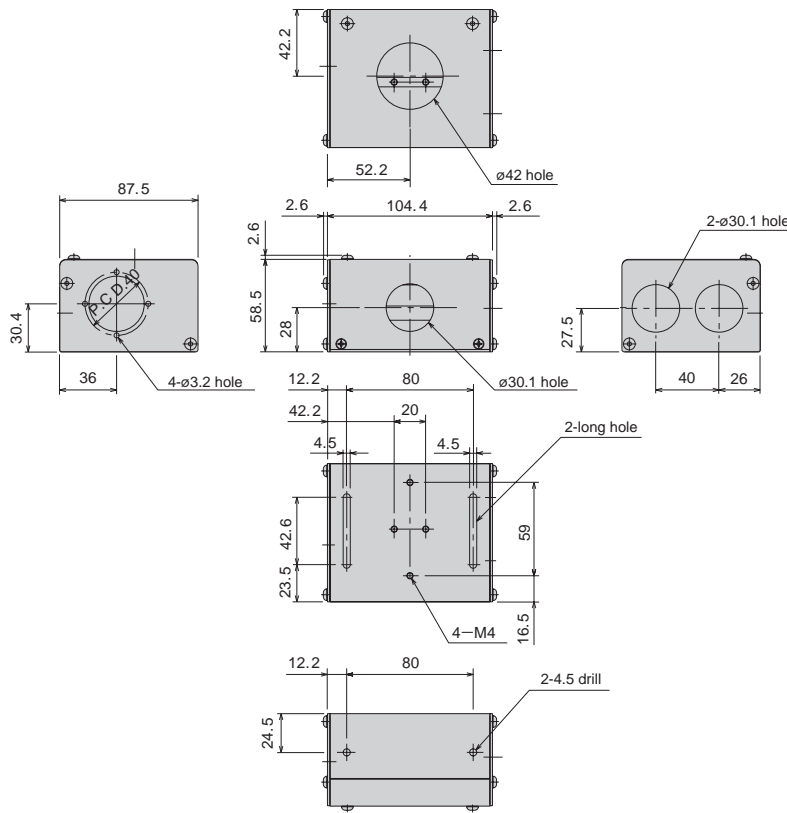

No.	Accessory	Q'ty	
1	1.6 9.9 $\phi 35$	1	
2	41 9 43.6 G1 (Nut thread) JIS B 0202	1	
3	42 4 15 45.5 G1 (Nut thread) JIS B 0202	1 set	
4	1.6 9.9 $\phi 30$	3	
5	6.5 1.5 $\phi 30$ $\phi 35$	3	
6	Cross recessed pan head screw	M4x8	2
7	Hexagon nut	M4	2

[BA10-BX-B30] Exclusively used for flexible tube L size (BA10-FT-L □ □)

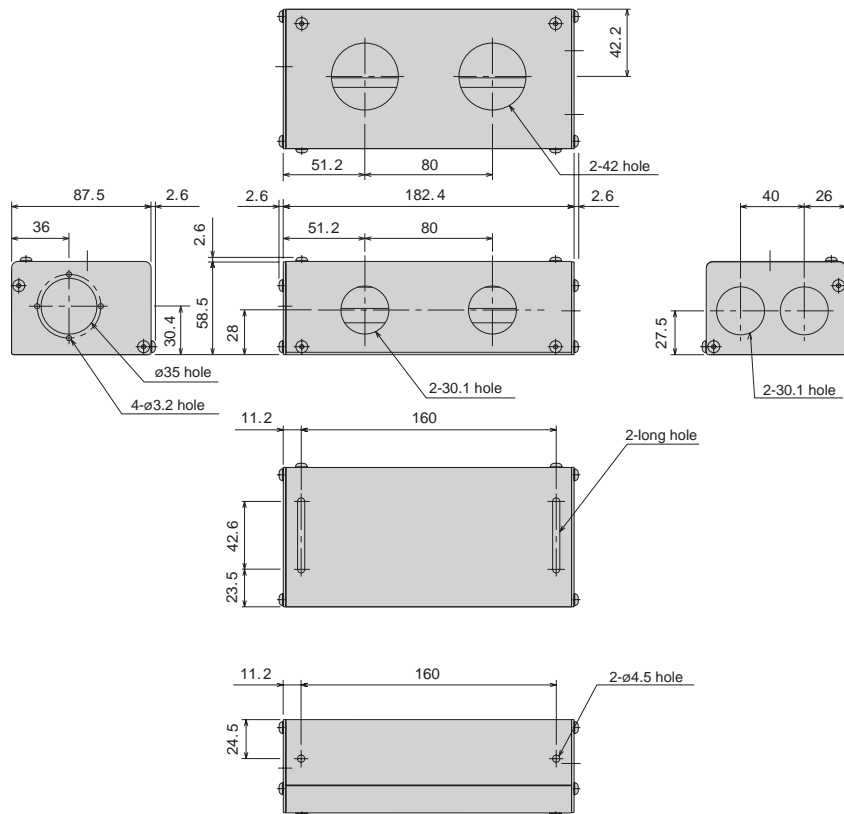

No.	Accessory	Q'ty	
1	1.6 9.9 $\phi 35$	1	
2	41 9 43.6 G1 (Nut thread) JIS B 0202	1	
3	42 4 15 45.5 G1 (Nut thread) JIS B 0202	1 set	
4	1.6 9.9 $\phi 30$	4	
5	6.5 1.5 $\phi 30$ $\phi 35$	4	
6	Cross recessed pan head screw	M4x8	2
7	Hexagon nut	M4	2

[Dimensions]

[BA10-BX-F10] Exclusively used for flexible duct (BA10-FD-□□□)

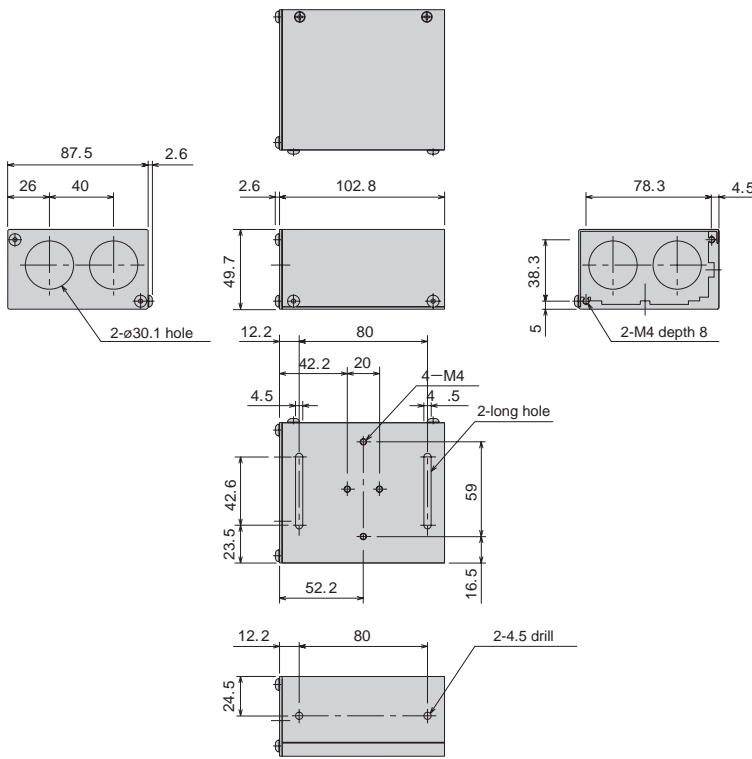

No.	Accessory	Q'ty	
1	1.6 9.9 ø30	1	
2	6.5 ø30 ø35 1.5	2	
3	Cross recessed pan head screw	M4x6	2
4	Hexagon nut	M4	2

[BA10-BX-F20] Exclusively used for flexible duct (BA10-FD-□□□)

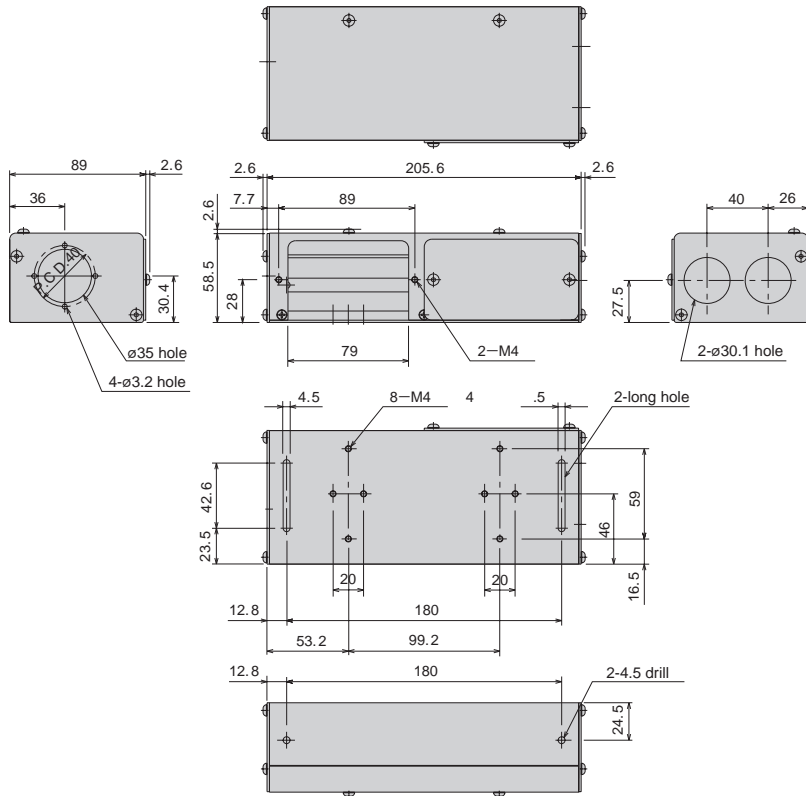

No.	Accessory	Q'ty	
1	1.6 9.9 ø35	1	
2	41 9 43.6 G1(Nut thread) JIS B 0202	1	
3	42 4 15 45.5 G1(Nut thread) JIS B 0202	1 set	
4	1.6 9.9 ø30	2	
5	6.5 ø30 ø35 1.5	2	
6	Cross recessed pan head screw	M4x6	2
7	Hexagon nut	M4	2

[BA10-BX-F30] Exclusively used for flexible duct (BA10-FD-□□□)

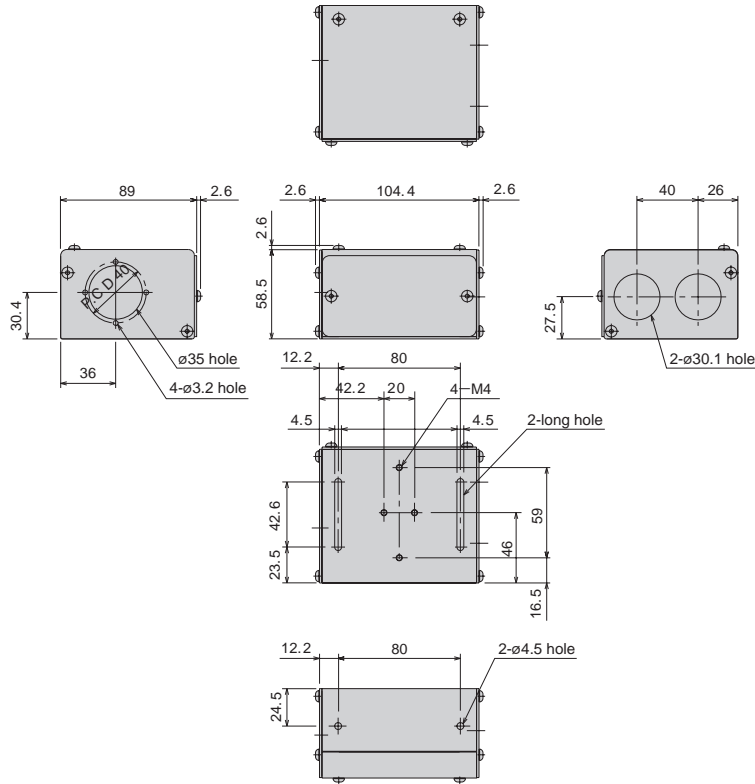

No.	Accessory	Q'ty	
1	1.6 9.9 $\phi 35$	1	
2	41 43.6 9 G1 (Nut thread) JIS B 0202	1	
3	42 45.5 4 15 G (Nut thread) JIS B 0202	1 set	
4	1.6 9.9 $\phi 30$	2	
5	6.5 30 35 1.5	2	
6	Cross recessed pan head screw	M4x8	2
7	Hexagon nut	M4	2

CN Box Wrench

[Code designation]

CGSP - 41

[Application]

This is a special wrench used for clamping the resin nut of the cable grip to the CN box and actuator

[Dimensions]

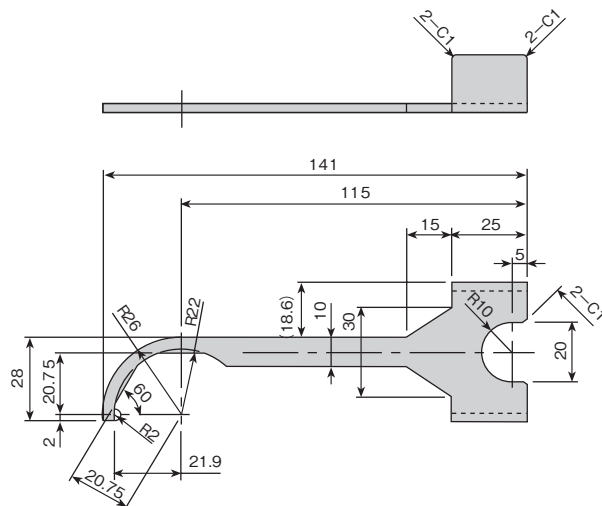

Flexible Tube

[Application]

Used to protect a controller cable which connects the Cartesian two axes. It is also possible to pass a signal cable for tooling or other air tubing through this flexible tube. This flexible tube can be arranged vertically (cable track style) or horizontally (hoop cable style; only M size). To use this tube, an exclusive CN box (available at an extra cost) is necessary.

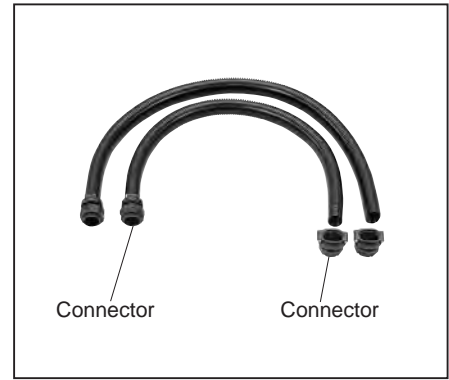

[Code designation]

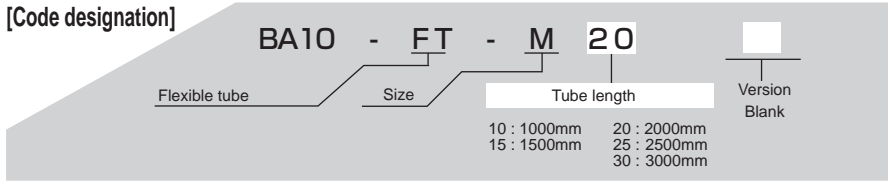

- * Two special connectors, and clamps and bands for securing each cable at the tube inlet are attached.
- * The tube section is oval and cannot be twisted between the tube and connector.
- * The flexible tube can be severed easily by using a cutter knife. When connecting the tube, allow enough radius of curvature.
- * As a yardstick, the length of flexible tube which connects Cartesian two axes is three times the stroke of the axis 1.
- * Select the flexible tube which connects with the axis 2 slider (or axis end for the case of moving-axis), according to the form of installation.

[Dimensions]

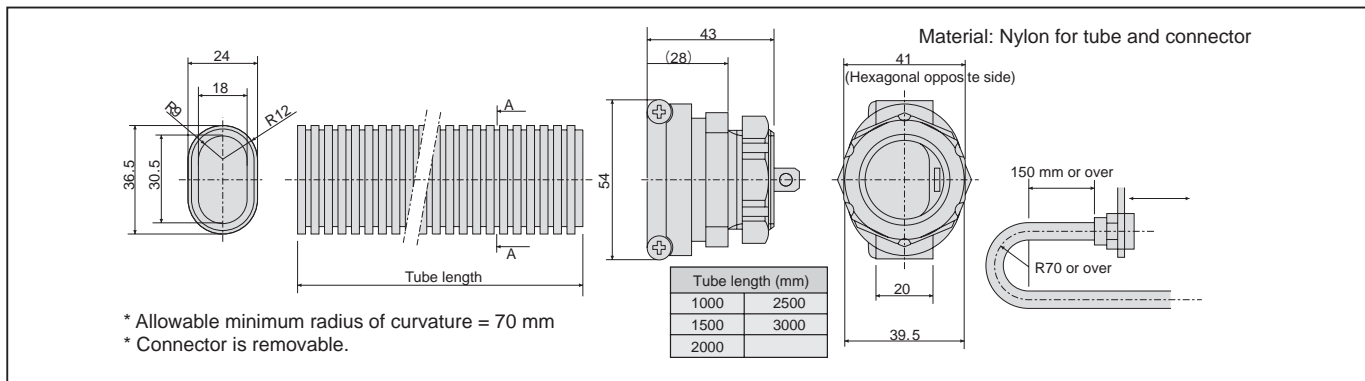

[Code designation]

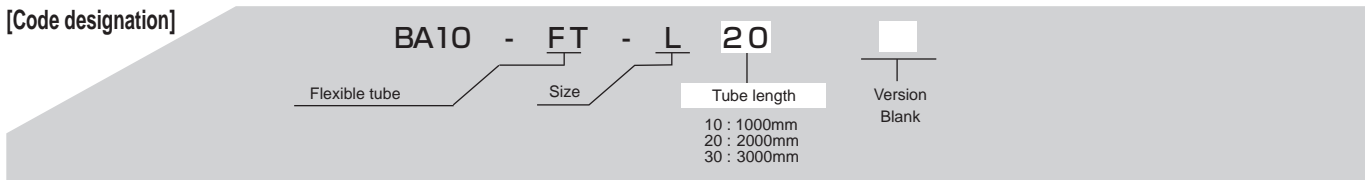

- * Two special connectors are attached.
- * The flexible tube can be severed easily by using a cutter knife. When connecting the tube, allow enough radius of curvature.
- * As a yardstick, the length of flexible tube which connects Cartesian two axes is three times the stroke of the axis 1.

[Dimensions]

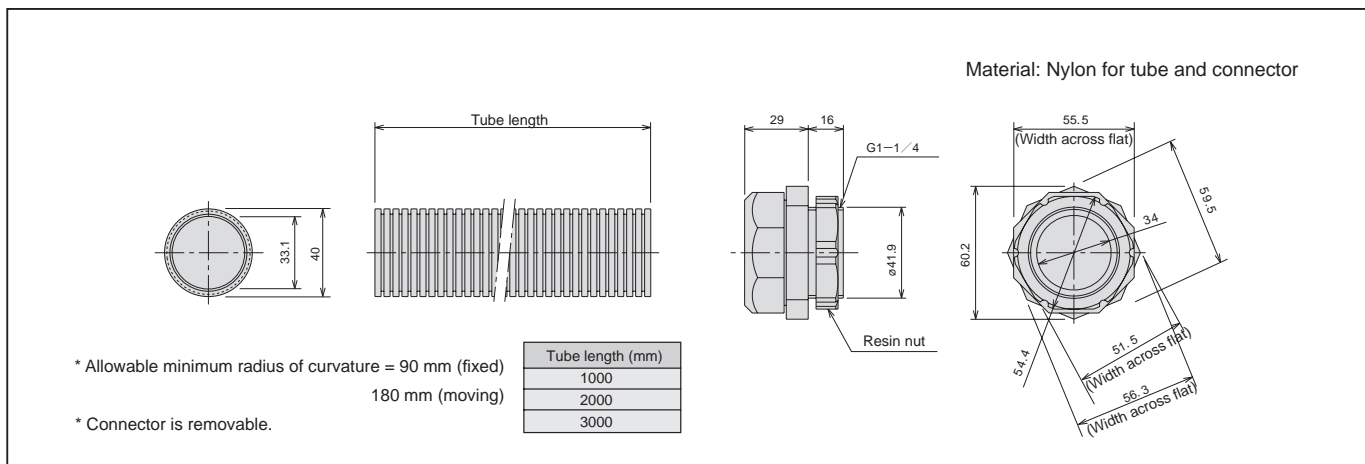

Flexible Duct

[Application]

Used to protect a controller cable which connects with the moving part. It is also possible to pass a signal cable for tooling or air tubing through this flexible duct. To use this duct, an exclusive CN box (available at an extra cost) is necessary.

[Code designation]

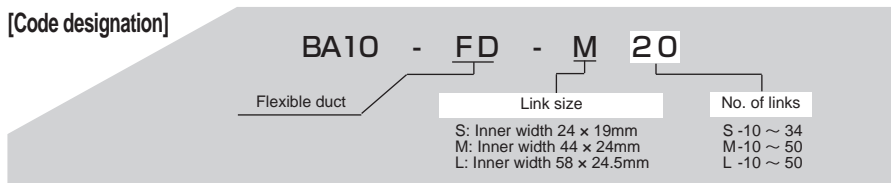

- * Select the flexible duct which has enough clearance for cables and tubes to pass through.
- * Select the number of links with good margin, referring to the duct selection stated below.

[Duct selection for connecting axis 1 and axis 2]

- [1] Select the link size.
- [2] Figure out the full length (L) of the duct.
- [3] Figure out the number of links required (A).

Full length of duct (L) = Basic length (B) + X-axis stroke (X)
 No. of links (A) = Full length of duct ÷ Link pitch (C)
 Note: Fraction of the number of links is to be rounded up.

Combination	Axis 1	Axis 2	Link size	Basic length mm (B)
X - Y	BE30-ST	BE10-ST	M (L is applicable.)	585
	BE30-UR/UL	BE10-UR/UL	M (L is applicable.)	360
	BE50-ST	BE30-ST	L (M is applicable.)	630
	BE50-UR/UL	BE30-ST	L (M is applicable.)	540
X - Z	BE30-ST	BE10-ST	M (L is applicable.)	630
	BE30-UR/UL	BE10-UR/UL	M (L is applicable.)	360
	BE50-ST	BE30-ST	L (M is applicable.)	765
	BE50-UR/UL	BE30-UR/UL	L (M is applicable.)	675

Link size	Pitch mm (C)
S	32
M	45
L	45

* Shown above are representative examples. For other combinations, contact us.

[Dimensions]

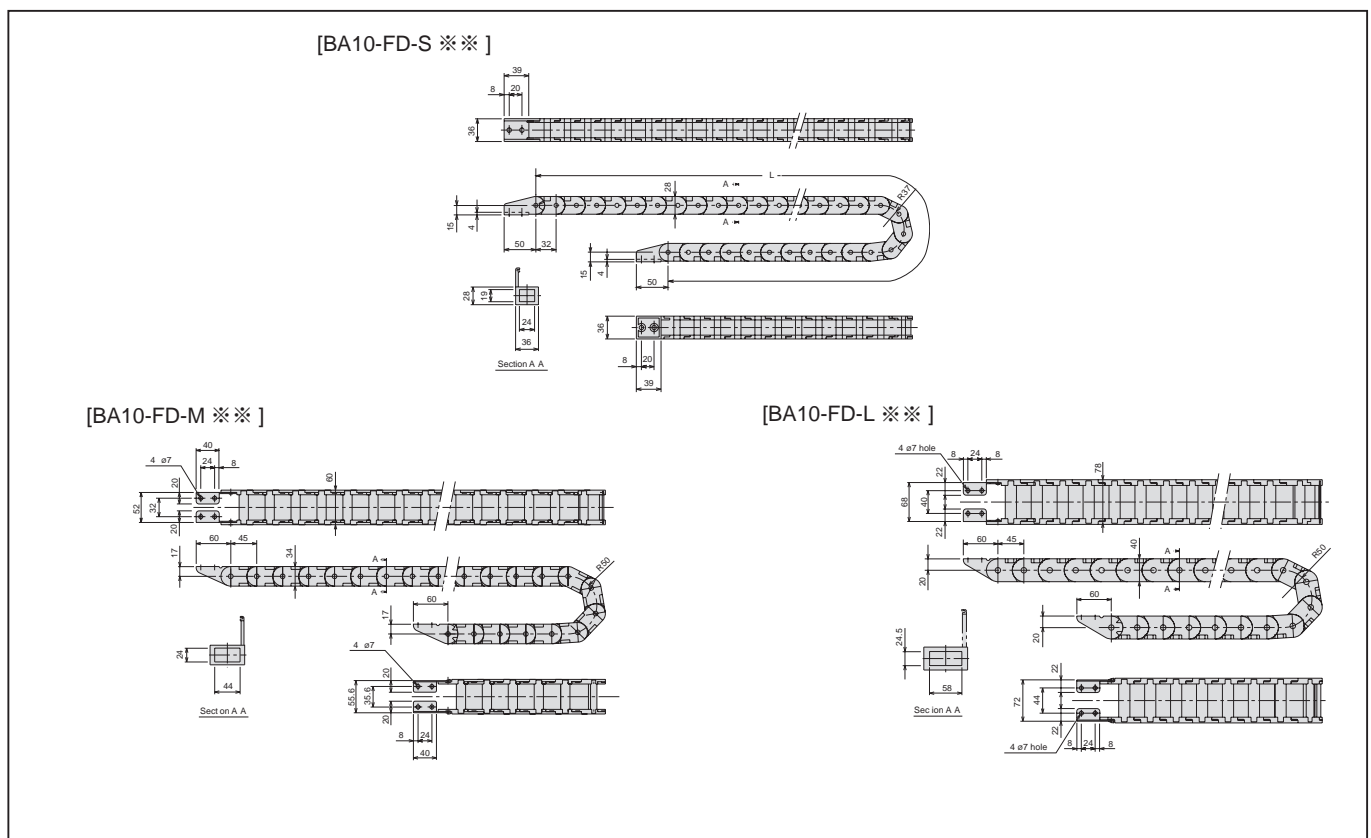

Tube Tray

[Application]

Used to hold a flexible tube when the tube is placed horizontally.
This tray is secured to the 4 mm-wide T-slot on the side of the actuator.
It not only supports a flexible tube, but also prevents lateral movement of the tube.

[Code designation]

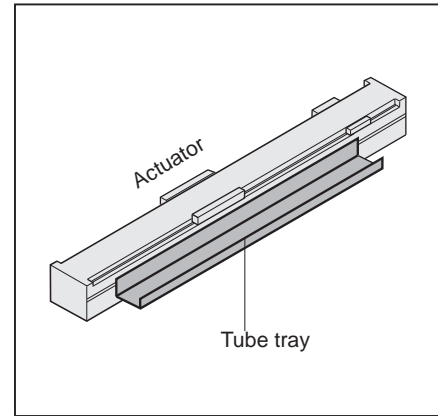
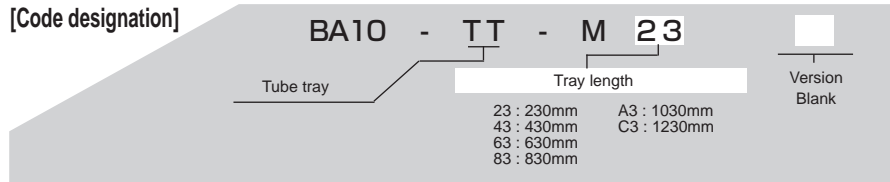

[Dimensions]

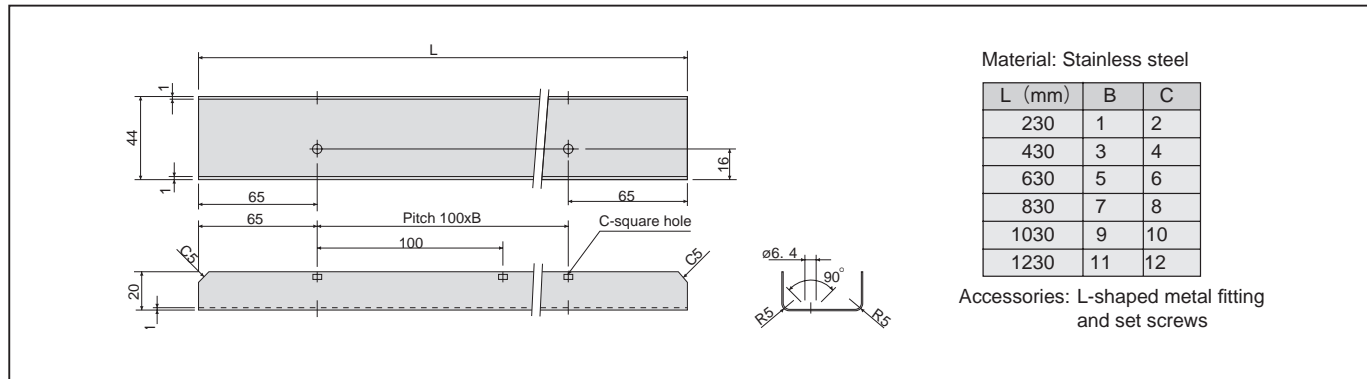

Flexible Tray

[Application]

Used to hold a flexible duct.
This tray is secured to the 4 mm-wide T-slot on the side of the actuator.
It prevents lateral movement of the duct.

[Code designation]

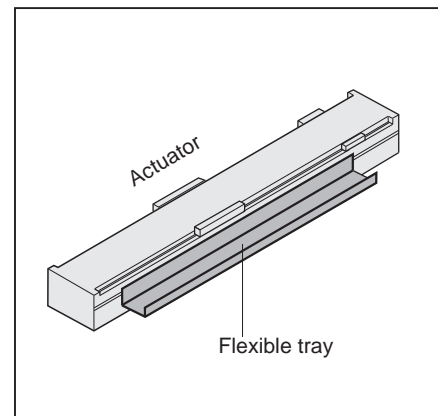
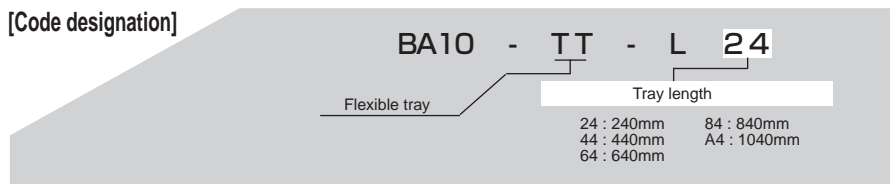

[Dimensions]

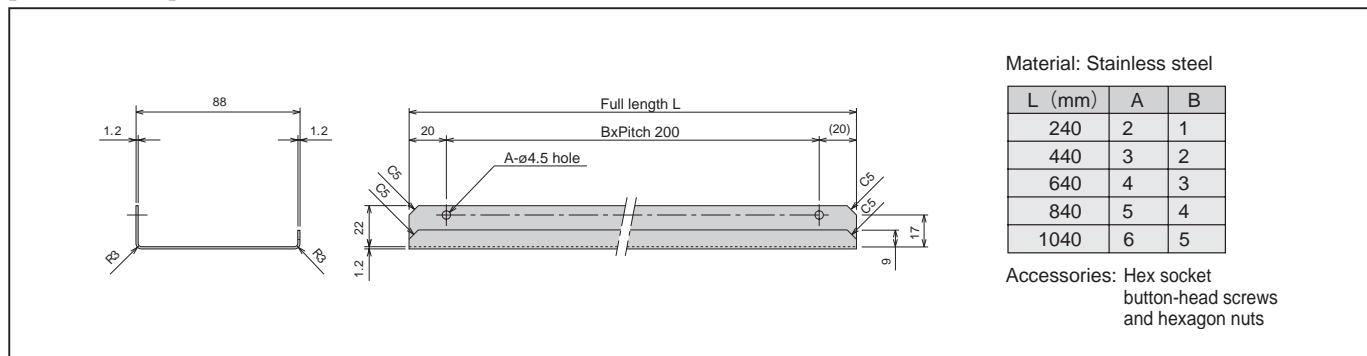

Support Guide

[Application]

This is a guide rail which is used to support the Y-axis end. When the support guide is mounted on the end of the Y-axis, moment imposed on the X-axis can be reduced with less deflection of the Y-axis. It is useful for the work requiring rigidity or long Y-axis stroke.

[Code designation]

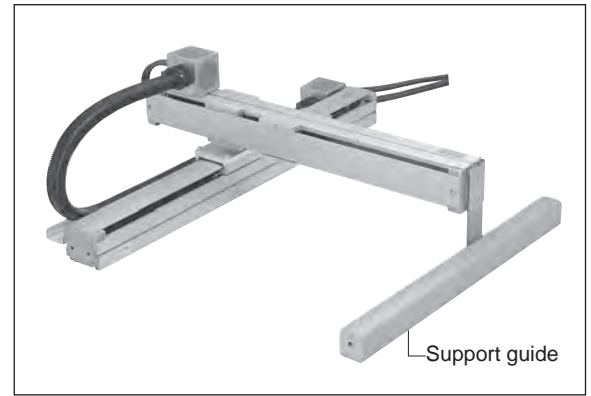
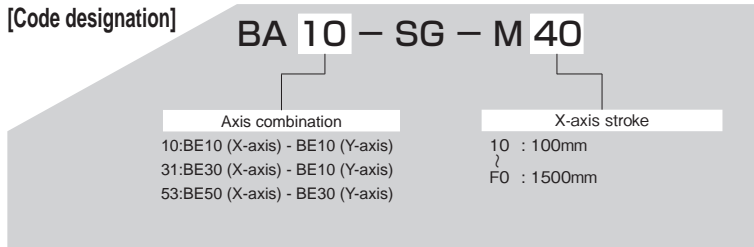

■ Deflection ■

As shown in the right figure, deflection is measured by exerting 5 kg load on the slider with the Y-axis slider located on the end. (Example) X-axis : BE10E-ST-M, Y-axis : BE10E-ST-S (450mm stroke)

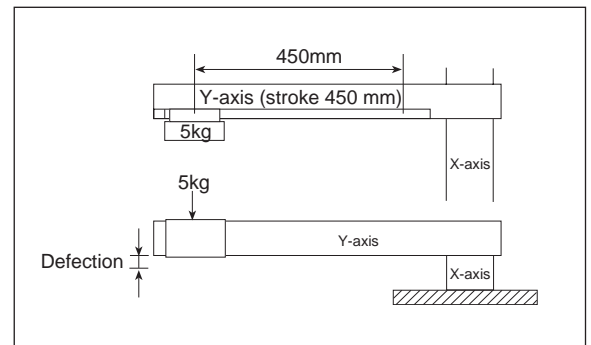

	Deflection
Without support guide	0.4mm
With support guide	0.07mm

[Payload]

As moment exerted on the X-axis can be reduced, payload for axis combination can be increased, which differs with the type of combination. For details, contact our sales office in your territory.

[Outer dimensions]

BA10-SG

X-axis: BE10 - -M N-

Y-axis: BE10 - -S N-

Common to both ball screw drive type and timing belt drive type.

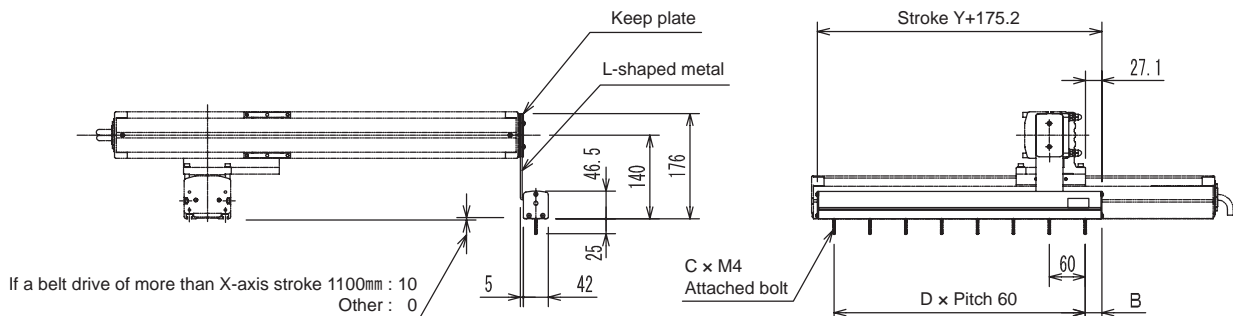
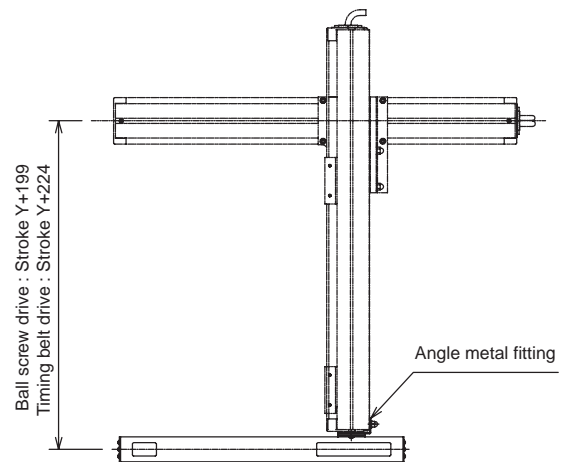

If a belt drive of more than X-axis stroke 1100mm : 10
Other : 0

Stroke X (mm)	100	200	300	400	500	600	700	800	900	1000	1100	1200	1300	1400	1500
B (mm)	17.6	7.6	27.6	17.6	7.6	27.6	17.6	7.6	27.6	17.6	7.6	27.6	17.6	7.6	27.6
C (q'ty)	5	7	8	10	12	13	15	17	18	20	22	23	25	27	28
D	4	6	7	9	11	12	14	16	17	19	21	22	24	26	27

* Value "C" signifies the number of attached clamp bolts.

BA31-SG

X-axis: BE30 - -M N-

Y-axis: BE10 - -M N-

Common to both ball screw drive type and timing belt drive type.

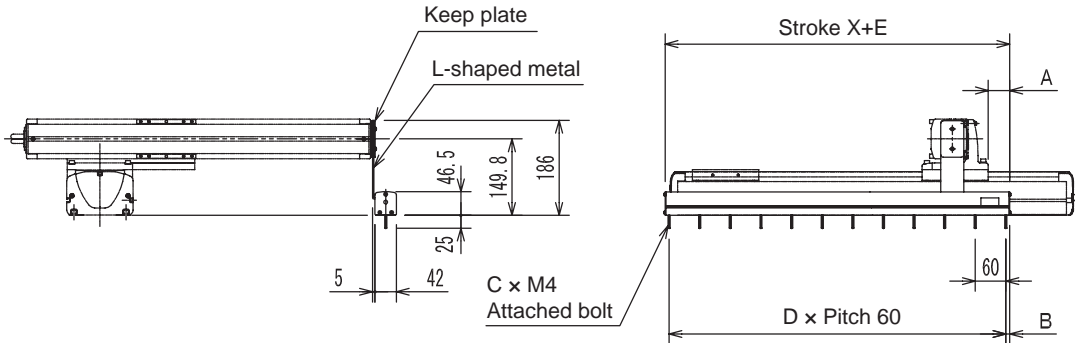
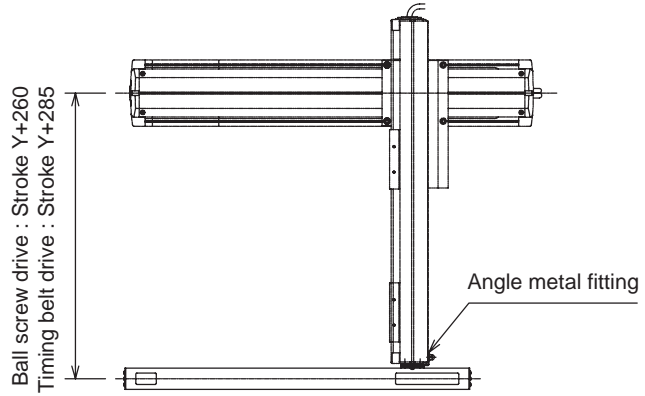

Stroke X (mm)	100	200(150)	300(250)	400(350)	500(450)	600(550)	700(650)	800(750)	900(850)	1000(950)	1100(1050)	1200	1300	1400	1500
A (mm)	17.1 (42.1)														
B (mm)	17.6	7.6	27.6	17.6	7.6	27.6	17.6	7.6	27.6	17.6	7.6	27.6	17.6	7.6	27.6
C (q'ty)	5	7	8	10	12	13	15	17	18	20	22	23	25	27	28
D	4	6	7	9	11	12	14	16	17	19	21	22	24	26	27
E (mm)	176 (226)														

* The values in parentheses are applicable only when BE30E-ST type (ball screw drive type) is used for the X-axis.

* Value "C" signifies the number of attached clamp bolts.

Options

BA53-SG

X-axis: BE50 - -M N-

Y-axis: BE30 - -M N-

Common to both ball screw drive type and timing belt drive type.

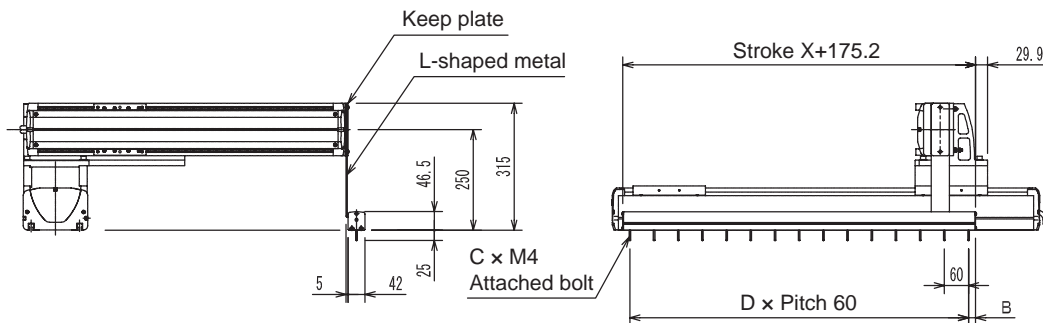
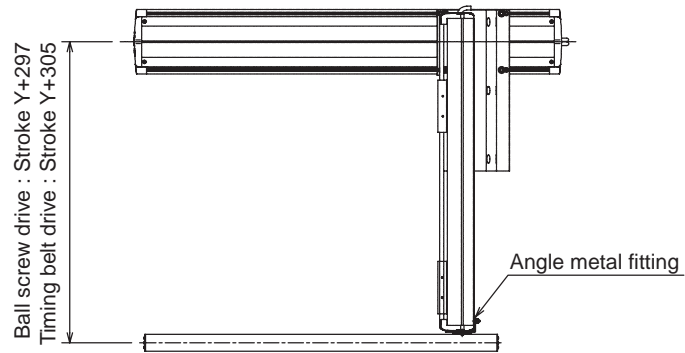

Stroke X (mm)	100	200	300	400	500	600	700	800	900	1000	1100	1200	1300	1400	1500
B (mm)	17.6	7.6	27.6	17.6	7.6	27.6	17.6	7.6	27.6	17.6	7.6	27.6	17.6	7.6	27.6
C (q'ty)	5	7	8	10	12	13	15	17	18	20	22	23	25	27	28
D	4	6	7	9	11	12	14	16	17	19	21	22	24	26	27

* Value "C" signifies the number of attached clamp bolts.

Home Position Change Sensor

[Application]

Used to change the return position of the axis slider to the end opposite to the motor side or mid-point of axis stroke. This function is effective when the home position is located at the stroke-end opposite the motor side. Also, when a moving-axis configuration is used, this sensor is required because the home position is located opposite to the motor side.

[Code designation]

HBS-BA 10

Applied axis

- 10 : Ball screw driven axis, High load specification belt driven axis (Stroke 1500 mm or less*)
- 20 : Timing belt driven axis (BE10, BE30, and BA50, Stroke 1500 mm or less*)
- 20L : Timing belt driven axis (BE10, BE30, and BA50, Stroke 2700 mm or less*)

* Please consult our sales agents, if it is used in longer stroke.

<When home position is located opposite the motor side>

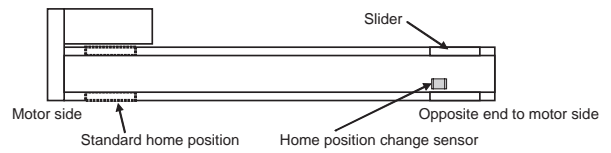

★ Change of controller parameter (motor rotating direction) is required.

<When home position is located at mid-point of axis stroke>

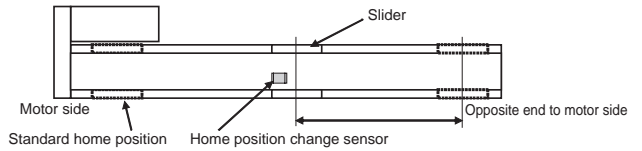

★ Be sure to mount a stopper to prevent the slider from moving by about 3 mm or over towards the motor side from the home position.

[Dimensions]

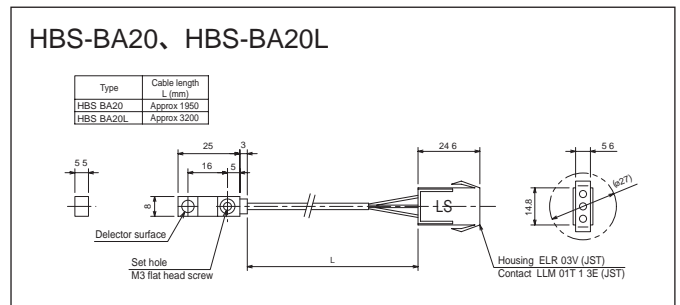
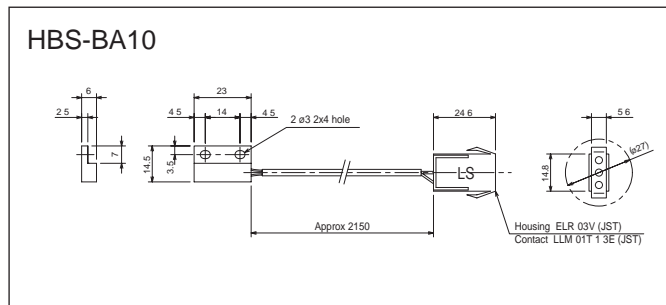

Strain Relief

[Application]

Used to set in the hole of CN box and secure the wire or tube when the user's wire or tube passes through the flexible tube. To mount the strain relief on the CN box, use a hole other than the holes used for the controller cable or flexible tube. The user's wire and controller cable are joined or branched in the CN box.

[Code designation]

BA10 - SC - A 02

Strain relief

Version
Blank

* Up to four bore sizes of the strain relief are available according to the cable size to be used.

[Dimensions]

Material: Flexible PCV for body
Polycarbonate for screw
Nylon for nut

Applicable conduit size (mm)

	Applicable conduit size (mm)
1st stage	φ 9 ~ 11
2nd stage	φ 11 ~ 14
3rd stage	φ 14 ~ 17
4th stage	φ 17 ~ 19

Cable Grip

[Application]

Used to seal the entry hole of the actuator or CN box to prevent a controller cable from being disconnected or moving in the flexible tube. This grip is intended for securing the controller cable. To secure the user's cable, use a strain relief. The cable grip comes in the two types ; for two cables of a single axis system and for four cables of a two-axis system.

[Code designation]

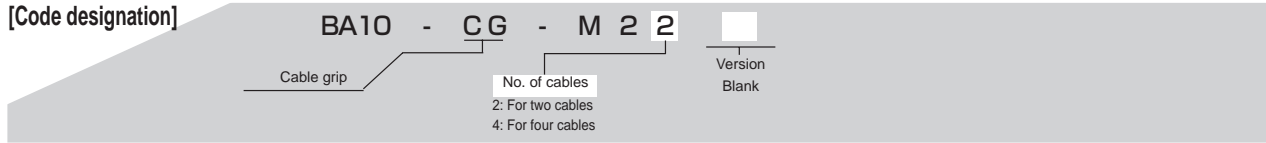

- * A cable grip can be split into two to facilitate the passing of a controller cable.
- * The controller cable is equipped with one cable grip for two cables, and the CN box with two cable grips for two cables.

[Dimensions]

Material: Nylon

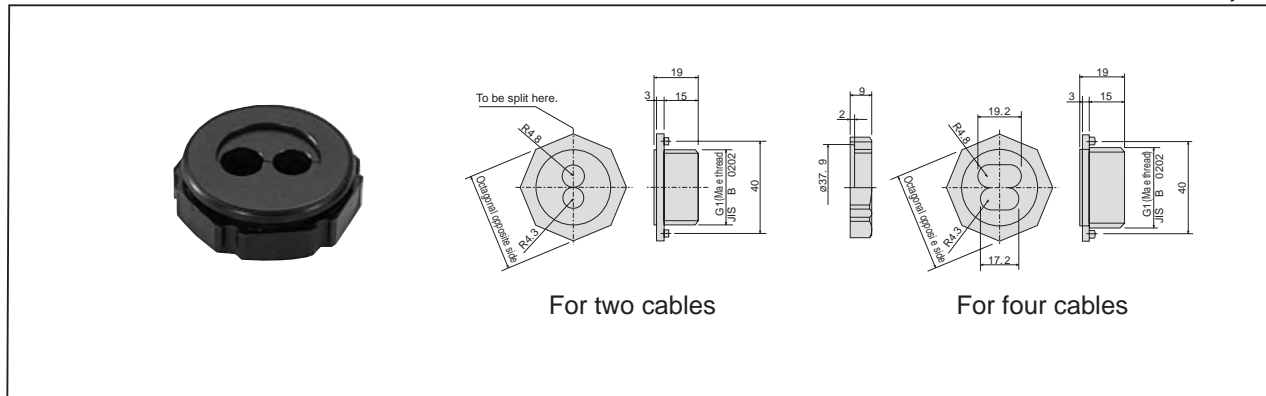

Control System Parts

Controller

Master Unit	164
Slave Unit	171
Slave Unit for BAC Axis	176
Extension I/O Unit.....	178
CC-Link Unit	180
DeviceNet Unit.....	183
Regenerative Discharge Unit.....	186
Teach Pendant.....	191
Link Cable.....	191
I/O Cable.....	192
PC Software.....	193
Communication Cable	194
Lithium Battery for Encoder Back-up	195

Master Unit

- * This is used as a master unit for the control of single-axis models to four-axis models. It includes a driver board for a single axis. Programs use the same COMPO ARM language as before for enabling easy teaching.
- * The power supply uses multi-power (100 V to 115 V AC, 200 V to 230 V) for supporting globalized production. (Note: The CA25-M40 and C25-M80 use 200 V to 230 V AC power only.)
- * The input signal can be selected from NPN type or PNP type.
- * In sequential mode, a multitask function (number of controlled axes: maximum 4 axes per 4 tasks) capable of handling up to four tasks is provided for enabling the simultaneous execution of multiple jobs.
- * Teach pendant THP-4C is used.

[Code designation]

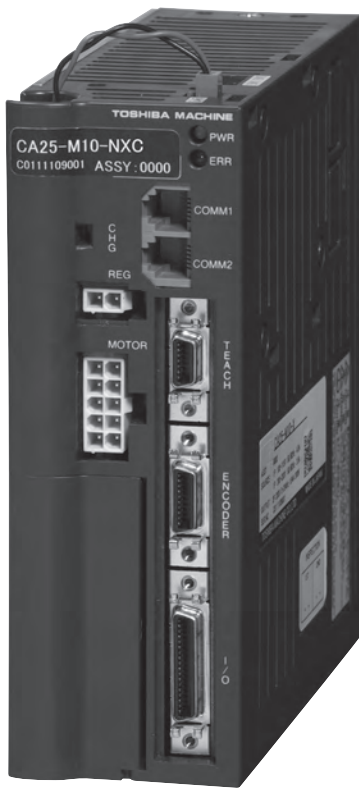
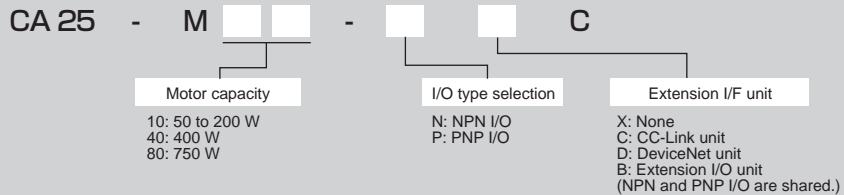

CA25-M10-*XC



CA25-M40-*XC
CA25-M80-*XC

Controller

Supported axis models

CA25-M10: BET3D, BET4D, BET5D, BET5E, BET7D, BE10E, BE10F, BE30E, BE30F, BE50F
 CA25-M40: BE50G, BE60G
 CA25-M80: BE60J

[System Configuration]

BA III Series axis: Maximum of 4 axes

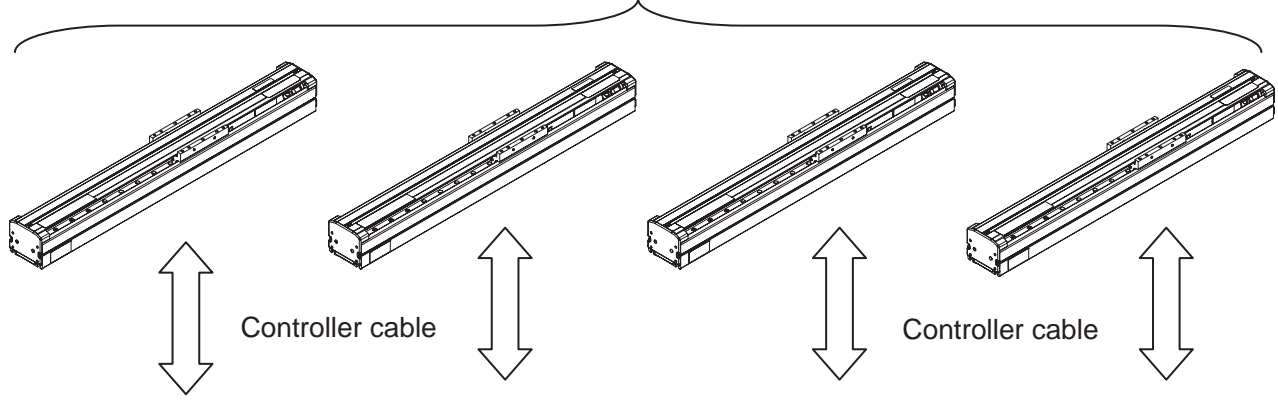

Master unit

Slave unit: Maximum of 3 units

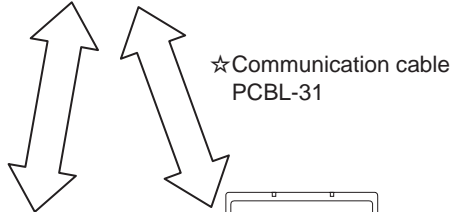
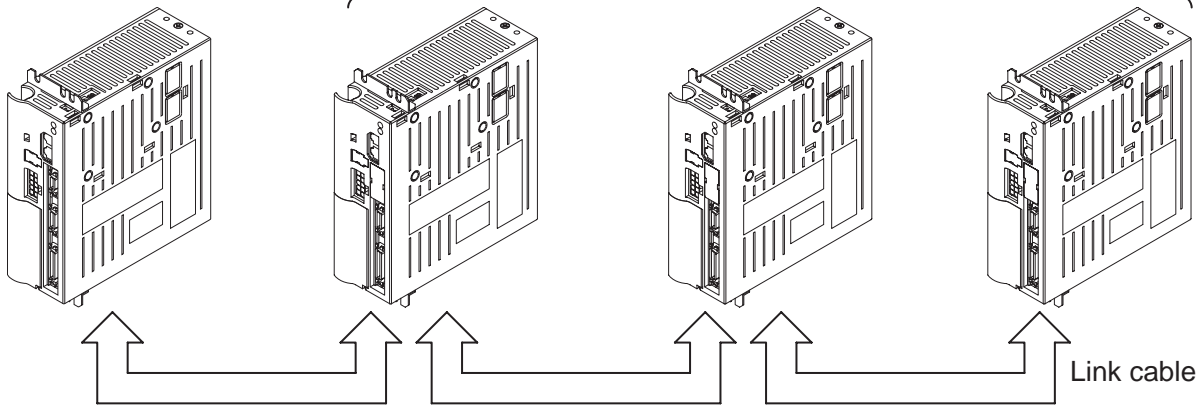

☆ Communication cable PCBL-31

* Host computer

☆ Teach pendant TPH-4C

☆ PC software SF-98D (Windows CD-ROM)

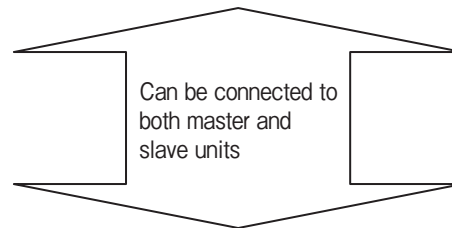
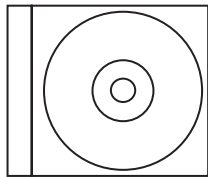

Can be connected to both master and slave units

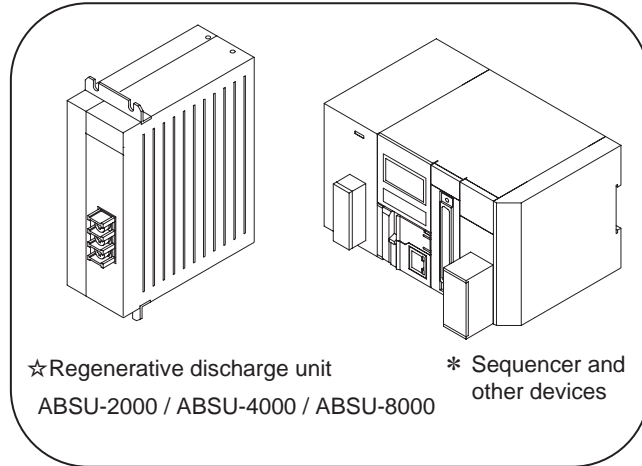

☆ Option
* Provided by customer

Controller

[Master Unit Specifications]

Applicable robot		COMPO ARM BA III series				
Controller model		CA25-M10		CA25-M40 *1	CA25-M80 *2	
Number of controlled axes		1 axis control or simultaneous 2- to 4-axis control by connecting a slave unit				
Motor capacity *3		50W	100W	200W	400W	750W
Drive system		AC servomotor				
Control system		PTP, CP, semi-closed loop control				
Teaching method		Remote teaching, direct teaching, or MDI				
Speed setting		10 steps (variable)				
Acceleration setting		20 steps (variable)				
Operation mode		Sequential, palletizing, external point designation				
Operation method		Step, continuous, single				
CPU		32-bit RISC CPU				
Home position sensor input		Included				
Regenerative function		Included (ABSU-2000 installed)		Included (ABSU-4000 installed)	Included (ABSU-8000 installed)	
Dynamic brake function		Not included				
Self-diagnosis function		CPU error, memory error, driver error, power supply voltage error, program error, or other error by watchdog timers				
Number of programs		Sequential: 16, Palletizing: 16				
Program		Max. 2,500 steps + Coordinate table: 999 (Total number of all tasks)				
Number of steps						
Memory system		FRAM				
Number of counters		99				
Number of timers		9				
Error display		Error indicator lamp turns on (front panel), teach pendant				
External I/O	System input	24V 7 mA: 4 inputs				
	General-purpose input	24V 7 mA: 4 inputs *4				
	System output	24 V max. 100 mA: 4 outputs				
	General-purpose output	24 V max. 100 mA: 4 outputs *4				
Communication function		For teach pendant or for PC communication x 1 channel (RS-232C)				
Power supply		100 V to 115 V AC, 200 V to 230 V AC, ±10% 50/60 Hz (Switching between 100 V system and 200 V system by the short bar on VOLTAGE SELECT terminal on terminal block)			200 V to 230 V AC ±10% 50/60 Hz	
Power capacity (per axis)		140VA	210VA	600VA	1.2kVA	1.6kVA
Ambient conditions	Operating temperature range	0°C to 40°C				
	Operating humidity range	30% to 90% RH (no condensation)				
	Storage temperature range	-20°C to 70°C				
	Storage humidity range	30% to 90% RH (no condensation)				
	Environment	Indoor (not exposed to direct sunlight), 1000 m or less above sea level Location not exposed to dust, dirt, corrosive gases, or flammable gases				
	Vibrations	9.8 m/s ² or less				
Dimensions		55 (W)×160 (H)×150 (D) (Not including mounting fixtures)			85 (W)×160 (H)×150 (D) (Not including mounting fixtures)	
Weight		0.92kg			1.58kg	

Notes

(*1) When using the CA25-M40, be sure to use the regenerative discharge unit ABSU-4000.

(*2) When using the CA25-M80, be sure to use the regenerative discharge unit ABSU-8000.

(*3) Identify the applicable motor capacity using the naming format on the controller front panel.

Do not connect to a motor with a different capacity. This can lead to motor burn out or other damage.

(*4) General-purpose I/O can be used as an I/O signal for various system types based on the mode settings.

[Dimensional Diagrams]

Without option units

Controller model: CA25-M10-*XC

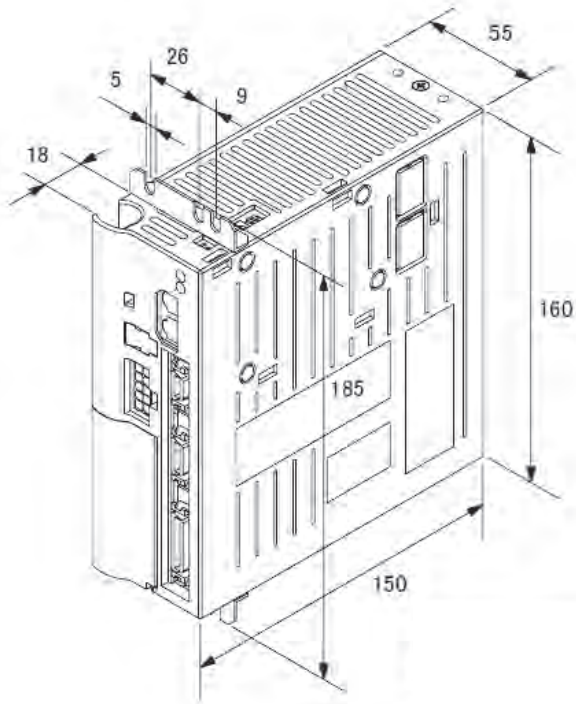

CA25-M40-*XC
CA25-M80-*XC

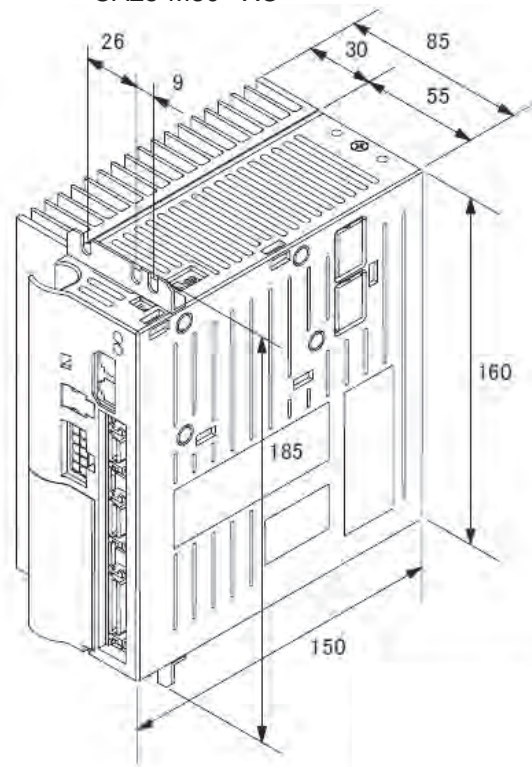

With option units

CA25-M10-**C

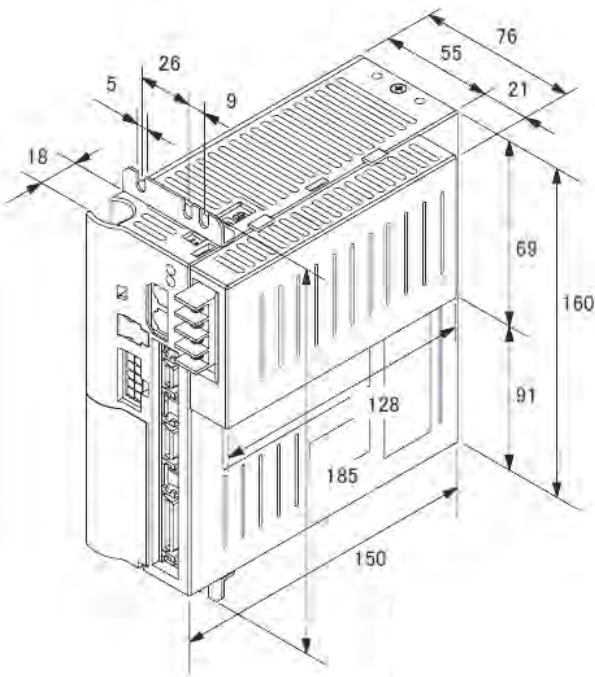

CA25-M40-**C
CA25-M80-**C

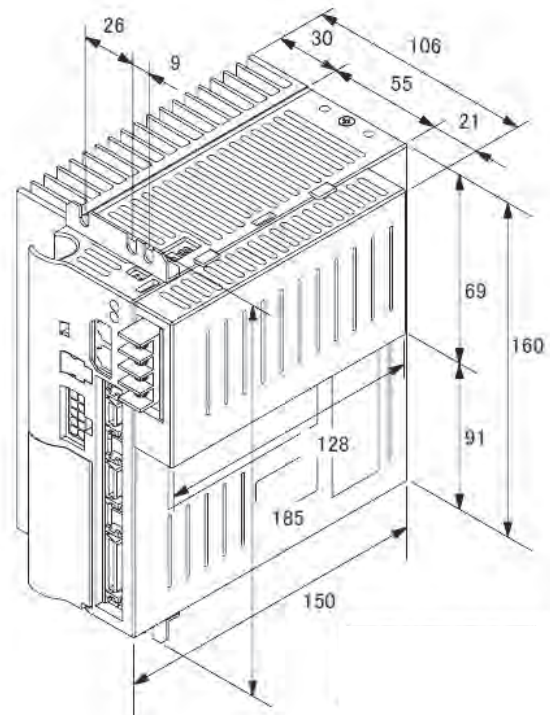

Controller

[Names and Functions of Each Part]

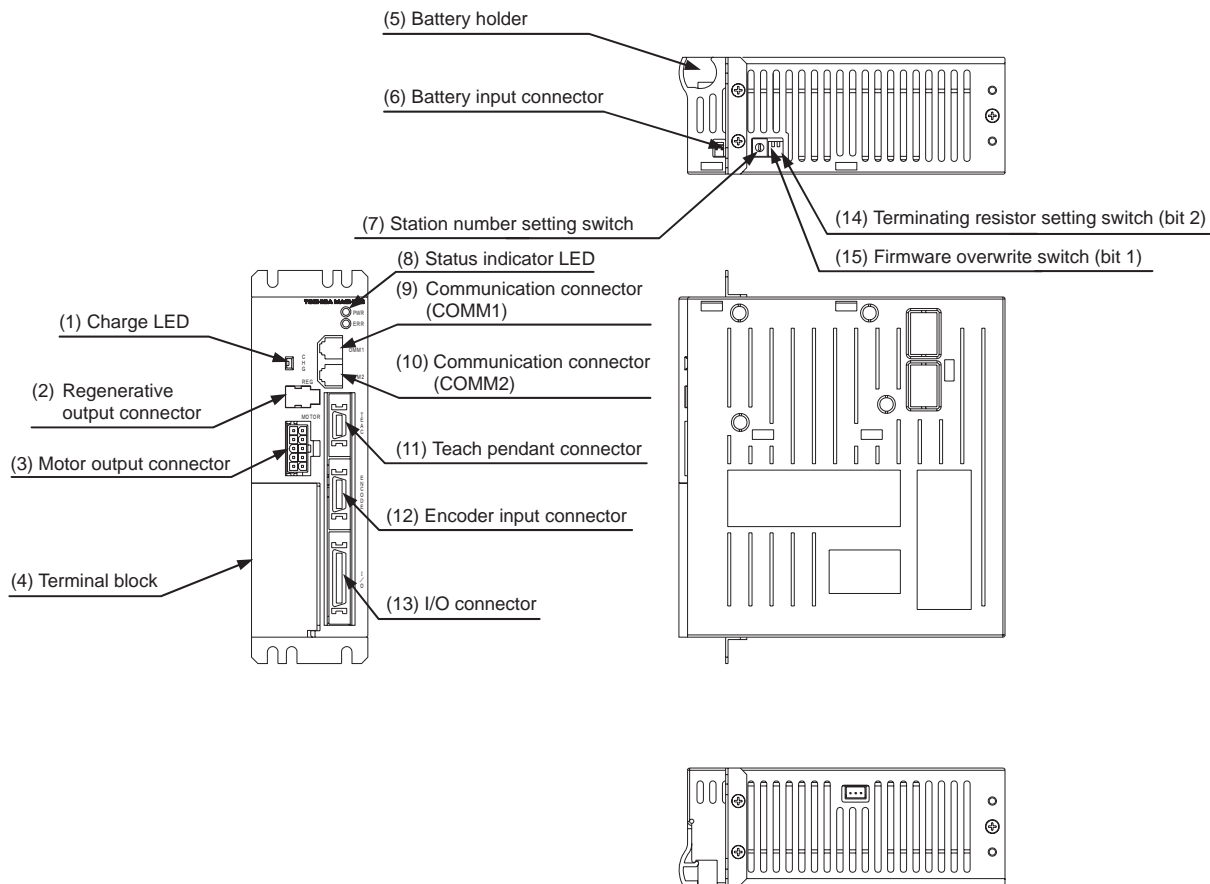

Notes

The above figure shows the CA25-M10. The CA25-S10 does not have a (11) Teach pendant connector. It is a blank panel.

- (1) Charge LED
This indicates the residual voltage status of the main circuit smoothing capacitor.
- (2) Regenerative output connector
This connector is used to connect the regenerative discharge unit (option).
- (3) Motor output connector
This connector is used to connect the motor controller cable.
- (4) Terminal block
This includes a power input terminal, power supply voltage switchover terminal, and FG (frame ground) and LG (line ground) terminals.
- (5) Battery holder
This houses the lithium battery for encoder backup.
- (6) Battery input connector
This connector is used to connect the battery harness.
- (7) Station number setting switch
This switch is used to set the station number of each slave unit when slave units are connected to control multiple axes. Set "0" for the master unit.
- (8) Status indicator LED
This is an LED indicating the controller status. When the power is turned on, it is lit green. When an error occurs, it is lit red. It flashes to indicate other statuses.
- (9) Communication connector (COMM1)
This connector is used to connect a link cable from an upper-level controller.
- (10) Communication connector (COMM2)
This connector is used to connect a link cable to a lower-level controller.
- (11) Teach pendant connector (master unit only)
This connector is used to connect the communication cable for the teach pendant or PC. This is a blank panel for slave units.
- (12) Encoder input connector
This connector is used to connect an encoder controller cable.
- (13) I/O connector
This connects an external control device (such as a sequencer).
- (14) Terminating resistor setting switch (bit 2)
This switch is used to set the terminating resistor for communication when a slave unit is connected.
- (15) Firmware overwrite switch (bit 1)
This switch is used when overwriting the controller firmware. Normally, it should be set to OFF. When set to ON, the controller does not start.

[Master Unit I/O Pin Numbers and Signals]

Controller models: CA25-M10, CA25-M40, CA25-M80

Pin no.	I/O	Signal name	Description	
			NPN I/O specifications	PNP I/O specifications
1	-	+COM1	+COM1	-COM5
2	OUT	OUT1	General-purpose output port	1-1 ←
3	OUT	OUT2	∕	1-2 ←
4	OUT	OUT3	∕	1-3 ←
5	OUT	OUT4	∕	1-4 ←
6	-	-COM1	-COM1 (*1)	+COM5 (*1)
7	OUT	EMONO	Emergency stop output (NO)	←
8	OUT	EMOCOM	Emergency stop output (COM)	←
9	OUT	EMONC	Emergency stop output (NC)	←
10	-	N.C	N.C	←
11	OUT	OUT5	Running output	←
12	OUT	OUT6	Error output	←
13	OUT	OUT7	Positioning complete output	←
14	OUT	OUT8	Home return complete output	←
15	-	N.C	N.C	←
16	-	N.C	N.C	←
17	-	-COM2	-COM2 (*1)	+COM6 (*1)
18	-	N.C	N.C	←
19	-	COM3	COM3 (*2)	←
20	IN	IN1	General-purpose input port	1-1 ←
21	IN	IN2	∕	1-2 ←
22	IN	IN3	∕	1-3 ←
23	IN	IN4	∕	1-4 ←
24	-	N.C	N.C	←
25	IN	EMIN+	Emergency stop input (+)	←
26	IN	EMIN-	Emergency stop input (-)	←
27	-	COM4	COM4 (*2)	←
28	IN	IN5	Home return input	←
29	IN	IN6	Start input	←
30	IN	IN7	Stop input	←
31	IN	IN8	Reset input	←
32	-	N.C	N.C	←
33	-	N.C	N.C	←
34	-	N.C	N.C	←
35	-	N.C	N.C	←
36	-	N.C	N.C	←

N.C : No Connection

Notes

- (*1) The no. 6 pin and no. 17 pin are connected internally.
 (*2) The no. 19 pin and no. 27 pin are not connected internally.

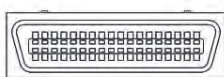
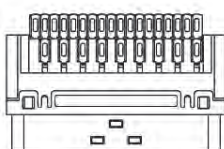
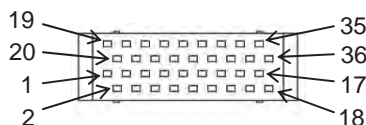

Use the supplied connectors.

- Cable-side connector models

Plug 54306-3619 (MOLEX)

Shell kit 54331-0361 (MOLEX)

- Panel-side connector models

Receptacle 52986-3621 (MOLEX)

Compliant wire size: AWG24 (0.22 mm²)

[Master Unit I/O Specifications]

Controller models: CA25-M10, CA25-M40, CA25-M80

General-purpose output circuit (NPN output)

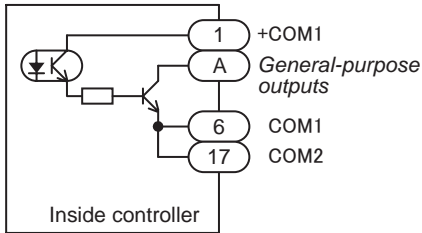

- 1) A: OUT1 to OUT4
- 2) Voltage: 24 V DC
- 3) Current: 100 mA (max.)
- 4) Photocoupler insulation
- 5) Open collector output

General-purpose output circuit (PNP output)

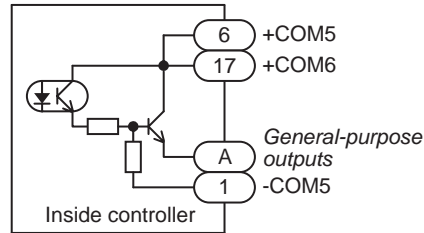

- 1) A: OUT1 to OUT4
- 2) Voltage: 24 V DC
- 3) Current: 100 mA (max.)
- 4) Photocoupler insulation
- 5) Emitter follower output

General-purpose input circuit (NPN and PNP common input)

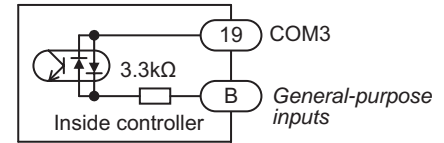

- 1) B: IN1 to IN4
- 2) Voltage: 24 V DC
- 3) Current: 7 mA
- 4) Photocoupler insulation

System output circuit (NPN output)

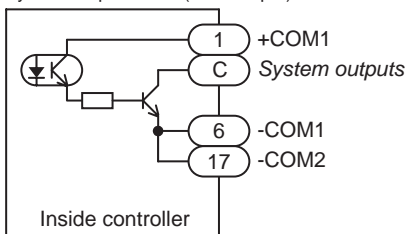

- 1) C: OUT5 to OUT8
- 2) Voltage: 24 V DC
- 3) Current: 100 mA (max.)
- 4) Photocoupler insulation
- 5) Open collector output

System output circuit (PNP output)

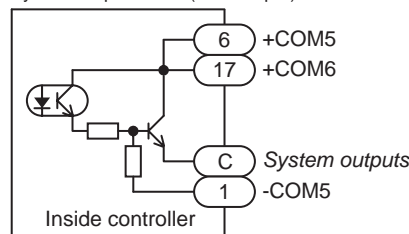

- 1) C: OUT5 to OUT8
- 2) Voltage: 24 V DC
- 3) Current: 100 mA (max.)
- 4) Photocoupler insulation
- 5) Emitter follower output

System input circuit (NPN and PNP common input)

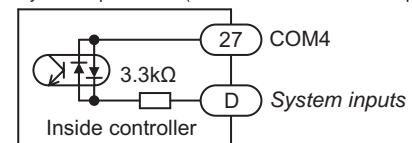

- 1) D: IN5 to IN8
- 2) Voltage: 24 V DC
- 3) Current: 7 mA
- 4) Photocoupler insulation

Notes

- The output circuit system types are NPN output specifications and PNP output specifications, and the controller model is different for each.
- The input circuit system types are identical for the NPN input specifications and PNP input specifications.
- This unit does not have an I/O power supply output (24 V DC). Supply from an external device.
- General-purpose I/O can be used as an I/O signal for various functions based on the mode settings.

Slave Unit

- * This unit is used as an auxiliary unit when controlling the master unit.
- * This unit includes a driver for single-axis driving.
- * The input/output signal can be selected from NPN type or PNP type.
- * The power supply uses multi-power (100 V to 115 V AC, 200 V to 230 V) for supporting globalized production. (Note: The CA25-S40 and CA25-S80 use 200 V to 230 V AC power only.)

[Code designation]

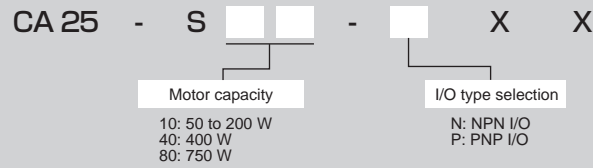

CA25-S10-*XX

CA25-S40-*XX
CA25-S80-*XX

Controller

Supported axis models

CA25-S10: BET3D, BET4D, BET5D, BET5E, BET7D, BE10E, BE10F, BE30E, BE30F, BE50F

CA25-S40: BE50G, BE60G

CA25-S80: BE60J

[Slave Unit Specifications]

Applicable robot	COMPO ARM BA III series				
Controller model	CA25-S10		CA25-S40 *1	CA25-S80 *2	
Number of controlled axes	1 axis control by connecting to a master unit				
Motor capacity *3	50W	100W	200W	400W	750W
Drive system	AC servomotor				
Home position sensor input	Included				
Regenerative function	Included (ABSU-2000 installed)		Included (ABSU-4000 installed)	Included (ABSU-8000 installed)	
Dynamic brake function	Not included				
Self-diagnosis function	Driver error, power supply voltage error, or other error				
Error display	Error indicator lamp turns on (front panel), teach pendant (connected to master unit)				
External I/O	General-purpose input	24V 7 mA: 8 inputs			
	General-purpose output	24V 100 mA: 8 outputs			
Power supply	100 V to 115 V AC, 200 V to 230 V AC, $\pm 10\%$ 50/60 Hz (Switching between 100 V system and 200 V system by the short bar on VOLTAGE SELECT terminal on terminal block)			200 V to 230 V AC $\pm 10\%$ 50/60 Hz	
Power capacity (per axis)	140VA	210VA	600VA	1.2kVA	1.6kVA
Ambient conditions	Operating temperature range	0°C to 40°C			
	Operating humidity range	30% to 90% RH (no condensation)			
	Storage temperature range	-20°C to 70°C			
	Storage humidity range	30% to 90% RH (no condensation)			
	Environment	Indoor (not exposed to direct sunlight), 1000 m or less above sea level Location not exposed to dust, dirt, corrosive gases, or flammable gases			
	Vibrations	9.8 m/s ² or less			
Dimensions	55 (W)×160 (H)×150 (D) (Not including mounting fixtures)			85 (W)×160 (H)×150 (D) (Not including mounting fixtures)	
Weight	0.92kg			1.58kg	

(*1) When using the CA25-S40, be sure to use the regenerative discharge unit ABSU-4000.

(*2) When using the CA25-S80, be sure to use the regenerative discharge unit ABSU-8000.

(*3) Identify the applicable motor capacity using the naming format on the controller front panel.

Do not connect to a motor with a different capacity. This can lead to motor burnout or other damage.

Notes

[Dimensional Diagrams]

Controller model: CA25-S10-*XX

CA25-S40-*XX

CA25-S80-*XX

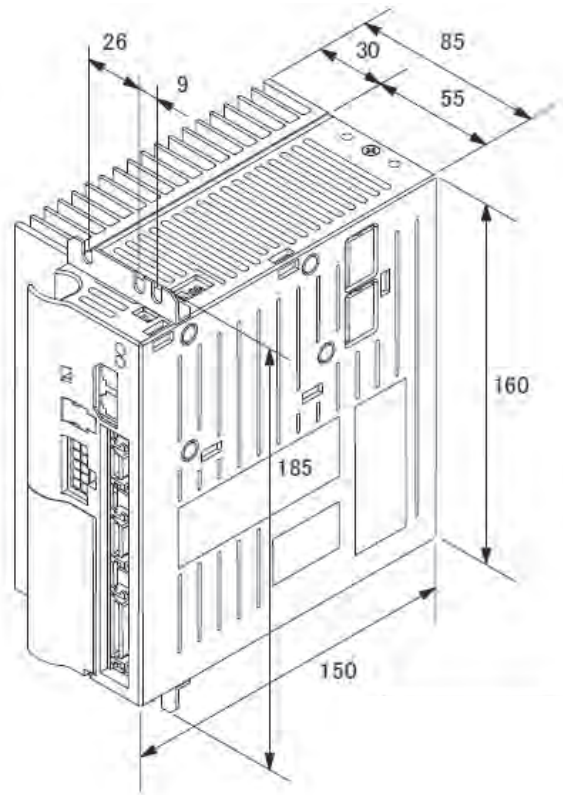
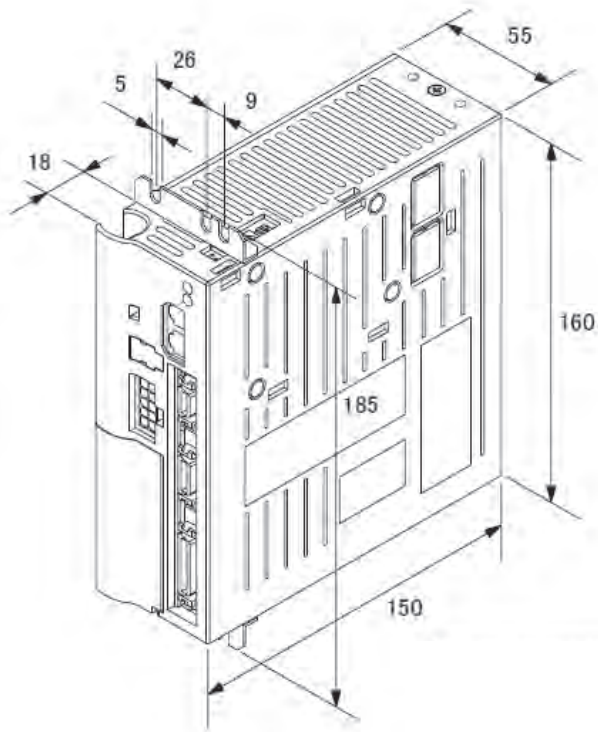

[Names and Functions of Each Part]

For the names and functions of each part, see the master unit items on page 168.

[Slave Unit I/O Pin Numbers and Signals]

Controller models: CA25-S10, CA25-S40, CA25-S80

Pin no.	I/O	Signal name	Description		
			NPN I/O specifications		PNP I/O specifications
1	-	+COM1	+COM1		-COM5
2	OUT	OUT1	General-purpose output port	1-1	←
3	OUT	OUT2	∕	1-2	←
4	OUT	OUT3	∕	1-3	←
5	OUT	OUT4	∕	1-4	←
6	-	-COM1	-COM1	(*1)	+COM5 (*1)
7	-	N.C	N.C		←
8	-	N.C	N.C		←
9	-	N.C	N.C		←
10	-	N.C	N.C		←
11	OUT	OUT5	General-purpose output port	1-5	←
12	OUT	OUT6	∕	1-6	←
13	OUT	OUT7	∕	1-7	←
14	OUT	OUT8	∕	1-8	←
15	-	N.C	N.C		←
16	-	N.C	N.C		←
17	-	-COM2	-COM2	(*1)	+COM6 (*1)
18	-	N.C	N.C		←
19	-	COM3	COM3	(*2)	←
20	IN	IN1	General-purpose input port	1-1	←
21	IN	IN2	∕	1-2	←
22	IN	IN3	∕	1-3	←
23	IN	IN4	∕	1-4	←
24	-	N.C	N.C		←
25	-	N.C	N.C		←
26	-	N.C	N.C		←
27	-	COM4	COM4	(*2)	←
28	IN	IN5	General-purpose input port	1-5	←
29	IN	IN6	∕	1-6	←
30	IN	IN7	∕	1-7	←
31	IN	IN8	∕	1-8	←
32	-	N.C	N.C		←
33	-	N.C	N.C		←
34	-	N.C	N.C		←
35	-	N.C	N.C		←
36	-	N.C	N.C		←

N.C : No Connection

Notes

- (*1) The no. 6 pin and no. 17 pin are connected internally.
 (*2) The no. 19 pin and no. 27 pin are not connected internally.

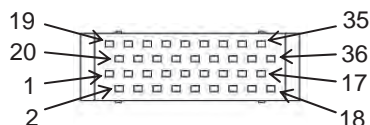

Use the supplied connectors.

- Cable-side connector models

Plug 54306-3619 (MOLEX)

Shell kit 54331-0361 (MOLEX)

- Panel-side connector models

Receptacle 52986-3621 (MOLEX)

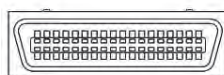
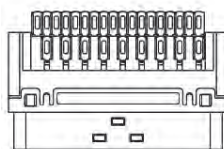

Compliant wire size: AWG24 (0.22 mm²)

[Slave Unit I/O Specifications]

Controller models: CA25-S10, CA25-S40, CA25-S80

General-purpose output circuit (NPN output)

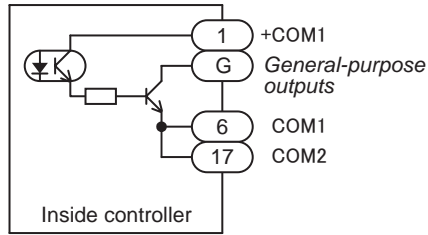

- 1) G: OUT1 to OUT8
- 2) Voltage: 24 V DC
- 3) Current: 100 mA (max.)
- 4) Photocoupler insulation
- 5) Open collector output

General-purpose output circuit (PNP output)

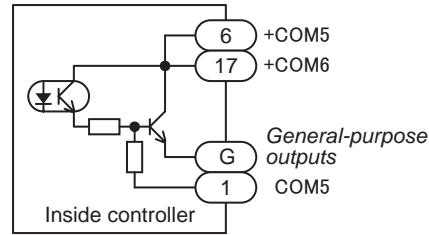

- 1) G: OUT1 to OUT8
- 2) Voltage: 24 V DC
- 3) Current: 100 mA (max.)
- 4) Photocoupler insulation
- 5) Emitter follower output

General-purpose input circuit (NPN and PNP common input)

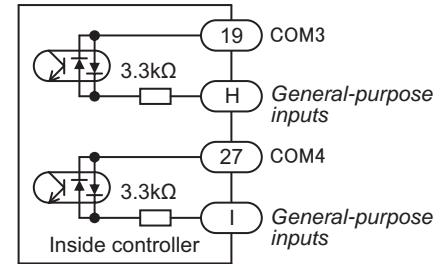

- 1) H: IN1 to IN4, I: IN5 to IN8
- 2) Voltage: 24 V DC
- 3) Current: 7 mA
- 4) Photocoupler insulation
- 5) The no. 19 pin and no. 27 pin are not connected internally.

Notes

- The output circuit system types are NPN output specifications and PNP output specifications, and the controller model is different for each.
- The input circuit system types are identical for the NPN input specifications and PNP input specifications.
- This unit does not have an I/O power supply output (24 V DC). Supply from an external device.
- General-purpose I/O can be used as an I/O signal for various functions based on the mode settings.

Slave Unit for BAC Axis

- * This is used as an auxiliary unit when controlling the master unit.
- * This unit includes a driver for single-axis driving of the BAC axis.
- * The power supply is 24 V DC.

[Code designation]

CA01 - S05

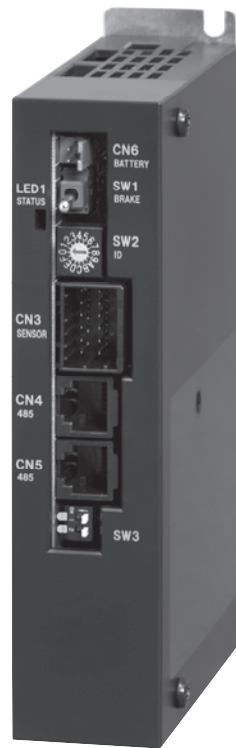

CA01-S05

Controller model: CA01-S05

Supported axis type: BAC3D, BAC4D, BAC5D, BAC7D

For the axis specifications, see the COMPO ARM BA-C series catalog.

Controller

[Slave Unit for BAC Axis Specifications]

Item	Description	
Applicable robot	COMPO ARM BA-C series	
Controller model	CA01-S05	
Number of controlled axes	1 axis control by connecting to a master unit	
Motor capacity	50W	
Drive system	AC servomotor	
Error display	Error indicator lamp turns on (front panel), teach pendant (connected to master unit)	
Home position sensor input	Included	
Regenerative function	Included (CAR-0500 or CAR-UN50 installed)	
Dynamic brake function	Not included	
Mechanical brake drive output	24 V DC-0.4 A or less (for brake, that holds when no magnetizing current is applied) Forced release possible by brake release switch (SW1)	
Protection functions	Hardware error	Sensor error, drive power supply error, nonvolatile memory error, etc.
	Software error	Speed exceeded, overload, positional deviation exceeded, etc.
	Warning	Low battery voltage
Status indicator	Lit green when power is on, lit red when error occurs	
External I/O	Not included	
Power supply	Control power supply voltage	24 V DC \pm 10%
	Drive power supply voltage	24 V DC \pm 10%
Power capacity (per axis)	Control power supply capacity	0.25A
	Drive power supply capacity	Based on axis model Rated 3 A (max. 9 A)
Ambient conditions	Operating temperature range	0°C to 40°C
	Operating humidity range	30% to 90% RH (no condensation)
	Storage temperature range	-20°C to 70°C
	Storage humidity range	30% to 90% RH (no condensation)
	Environment	Indoor (not exposed to direct sunlight) 1000 m or less above sea level Location not exposed to dust, dirt, corrosive gases, or flammable gases
	Vibrations/Impact	4.9 m/s ² or less / 19.6 m/s ² or less
Dimensions	31 (W) \times 146 (H) \times 89 (D) (Not including screw protrusions)	
Weight	Approx. 0.25 kg	

Notes

- Because the motor sensor resolution is low for the BA-C series (2048 pulses/rev), the value of the current position can appear offset by \pm 0.01 mm from the target position depending on the axis used. This offset occurs with respect to the absolute position, and it is not cumulative.
- For the "Dimensional Diagrams" and "Names and Functions of Each Part", see the BA-C series catalog.

Extension I/O Unit

The extension I/O unit is a board for adding 24 inputs and 8 outputs to the master unit. It is used when there are not enough input/output connectors on the controller. This board has bidirectional polarity for both the input circuit and output circuit.

Note: This cannot be installed by the customer.

[Code designation]

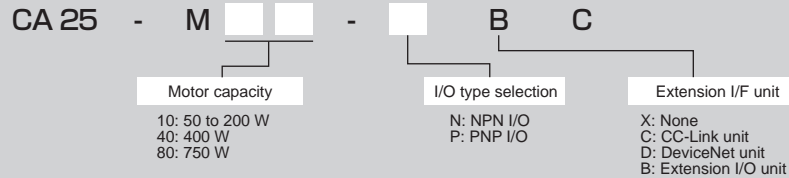

[Extension I/O Unit Pin Numbers and Signals]

CA25-M10-*BC

Pin no.	I/O	Signal name	Description		
			NPN I/O specifications		PNP I/O specifications
1	IN	IN9	General-purpose input port	2-1	←
2	IN	IN10	〃	2-2	←
3	IN	IN11	〃	2-3	←
4	IN	IN12	〃	2-4	←
5	IN	IN13	〃	2-5	←
6	IN	IN14	〃	2-6	←
7	IN	IN15	〃	2-7	←
8	IN	IN16	〃	2-8	←
9	IN	IN17	〃	3-1	←
10	-	COM7	COM7	(*1)	←
11	IN	IN18	General-purpose input port	3-2	←
12	IN	IN19	〃	3-3	←
13	-	COM8	COM8	(*2)	←
14	IN	IN20	General-purpose input port	3-4	←
15	IN	IN21	〃	3-5	←
16	IN	IN22	〃	3-6	←
17	IN	IN23	〃	3-7	←
18	IN	IN24	〃	3-8	←
19	IN	IN25	〃	4-1	←
20	IN	IN26	〃	4-2	←
21	IN	IN27	〃	4-3	←
22	IN	IN28	〃	4-4	←
23	IN	IN29	〃	4-5	←
24	IN	IN30	〃	4-6	←
25	IN	IN31	〃	4-7	←
26	IN	IN32	〃	4-8	←
27	OUT	OUT9	General-purpose output port	2-1	←
28	OUT	OUT10	〃	2-2	←
29	-	COM9	COM9	(*2)	←
30	OUT	OUT11	General-purpose output port	2-3	←
31	OUT	OUT12	〃	2-4	←
32	OUT	OUT13	〃	2-5	←
33	OUT	OUT14	〃	2-6	←
34	OUT	OUT15	〃	2-7	←
35	OUT	OUT16	〃	2-8	←
36	-	N.C	N.C		←

N.C : No Connection

Notes

- (*1) The no. 10 pin is not connected internally to the no. 13 or no. 29 pins.
- (*2) The no. 13 pin and no. 29 pin are connected internally.

Controller

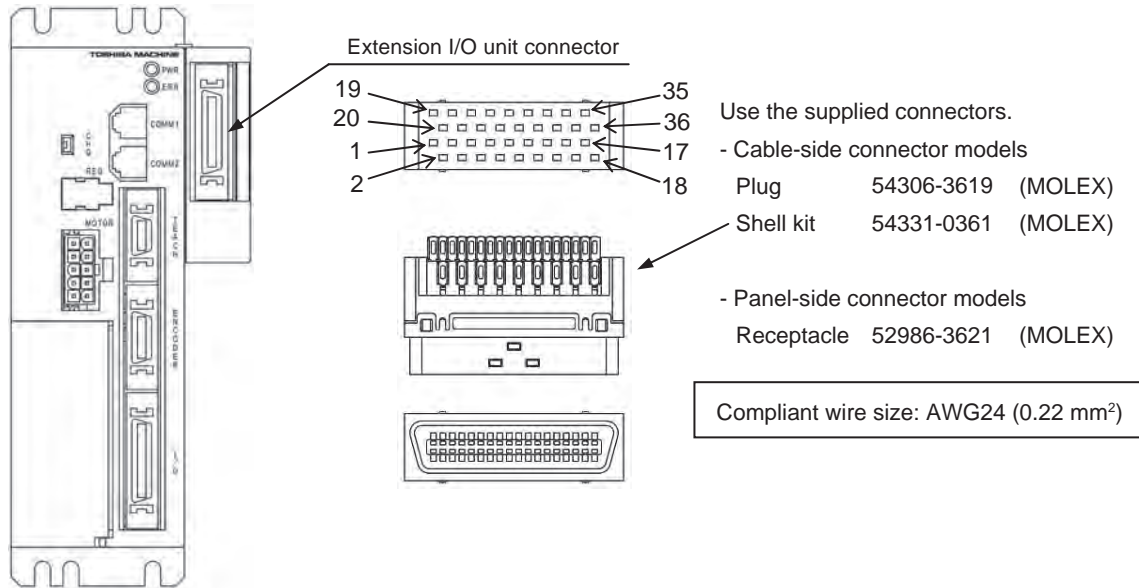

General-purpose output circuit (NPN and PNP common output)

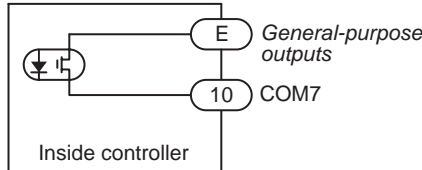

- 1) E: OUT9 to OUT16
- 2) Voltage: 24 V DC
- 3) Current: 50 mA (max.)
- 4) Photocoupler insulation
- 5) Photo MOS relay output

General-purpose input circuit (NPN and PNP common input)

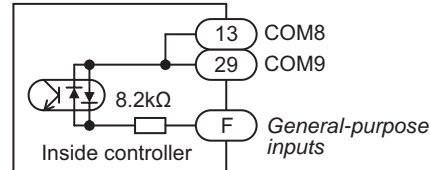

- 1) F: IN9 to IN32
- 2) Voltage: 24 V DC
- 3) Current: 3 mA
- 4) Photocoupler insulation

Notes

- The output circuit of the extension I/O unit is photo MOS relay output. It is identical for the NPN output specifications and PNP output specifications.
- The input circuit system types of the extension I/O unit are NPN input specifications and PNP input specifications.
- This unit does not have an I/O power supply output (24 V DC). Supply from an external device.
- General-purpose I/O can be used as an I/O signal for various systems based on the mode settings.

CC-Link Unit

CC-Link (Control & Communication Link) is a field network interface that enables reduced wiring with high-speed data communication. The CC-Link interface can be used to perform various input/output and data communication for the coordinate table, status, and jog operations.

Note: This cannot be installed by the customer.

[Code designation]

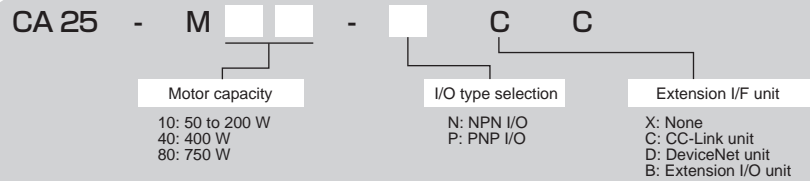

CA25-M10-CC

[Interface Specifications]

Item	Specifications
Communication specifications	CC-Link Ver1.10
Baud rate	10M, 5M, 2.5M, 625k, 156kbps (set by parameters)
Station type	Remote device station
Number of occupied stations	Fixed at 4 stations (RX/Ry: 128 points each, RWw/RWr: 16 points each)
Station number setting	1 to 64 (set by parameters)
Number of inputs/outputs	4 system inputs, 4 system outputs
	64 general-purpose inputs, 64 general-purpose outputs
	8 jog inputs, 8 jog outputs
	1 handshake input, 2 handshake outputs
	4 data selection inputs, 4 data selection confirmation outputs
Data communication function	Coordinate table transmission, current position monitor, error code request, status request, and more

*) These are the inputs and outputs as seen from the robot controller.

[I/O Signal List]

Signal direction CC-Link master station <- CA25-M10-*CC		Signal direction CC-Link master station --> CA25-M10-*CC (*1)	
Device no. (input)	Signal name	Device no. (output)	Signal name
RXn0	Output during operation	RYn0	Home return input
RXn1	Error output	RYn1	Start input
RXn2	Positioning complete output	RYn2	Stop input
RXn3	Home return complete output	RYn3	Reset input
RXn4 to RXn7	Usage prohibited	RYn4 to RYn7	Usage prohibited
RXn8 to RXnF	General-purpose output port 1-1 to 8	RYn8 to RYnF	General-purpose input port 1-1 to 8
RX(n+1)0 to RX(n+1)7	General-purpose output port 2-1 to 8	RY(n+1)0 to RY(n+1)7	General-purpose input port 2-1 to 8
RX(n+1)8 to RX(n+1)F	General-purpose output port 3-1 to 8	RY(n+1)8 to RY(n+1)F	General-purpose input port 3-1 to 8
RX(n+2)0 to RX(n+2)7	General-purpose output port 4-1 to 8	RY(n+2)0 to RY(n+2)7	General-purpose input port 4-1 to 8
RX(n+2)8 to RX(n+2)F	General-purpose output port 5-1 to 8	RY(n+2)8 to RY(n+2)F	General-purpose input port 5-1 to 8
RX(n+3)0 to RX(n+3)7	General-purpose output port 6-1 to 8	RY(n+3)0 to RY(n+3)7	General-purpose input port 6-1 to 8
RX(n+3)8 to RX(n+3)F	General-purpose output port 7-1 to 8	RY(n+3)8 to RY(n+3)F	General-purpose input port 7-1 to 8
RX(n+4)0 to RX(n+4)7	General-purpose output port 8-1 to 8	RY(n+4)0 to RY(n+4)7	General-purpose input port 8-1 to 8
RX(n+4)8 to RX(n+4)F	Jog output	RY(n+4)8 to RY(n+4)F	Jog input
RX(n+5)0 to RX(n+5)7	Reserved (*2)	RY(n+5)0 to RY(n+5)7	Reserved (*2)
RX(n+5)8 to RX(n+5)F		RY(n+5)8 to RY(n+5)F	
RX(n+6)0 to RX(n+6)7		RY(n+6)0 to RY(n+6)7	
RX(n+6)8	Command processing complete (*3)	RY(n+6)8	Command processing request (*3)
RX(n+6)9	Command error (*3)	RY(n+6)9	Usage prohibited
RX(n+6)A to RX(n+6)B	Usage prohibited	RY(n+6)A to RY(n+6)B	Usage prohibited
RX(n+6)C to RX(n+6)F	Data selection confirmation output	RY(n+6)C to RY(n+6)F	Data selection input
RX(n+7)0 to RX(n+7)7	Usage prohibited	RY(n+7)0 to RY(n+7)7	Usage prohibited
RX(n+7)8 to RX(n+7)F	Usage prohibited	RY(n+7)8 to RY(n+7)F	Usage prohibited



n: Address assigned to CA25-M10-*CC by the station number setting

*1) When CC-Link communication is cut off, the stop input is set to 1, and it is cleared to 0 in all other situations. The stop input is also cleared to 0 during teach pendant operation.

*2) Reserved area for future function expansion

*3) Handshake signals for data communication

[CC-Link Parts]

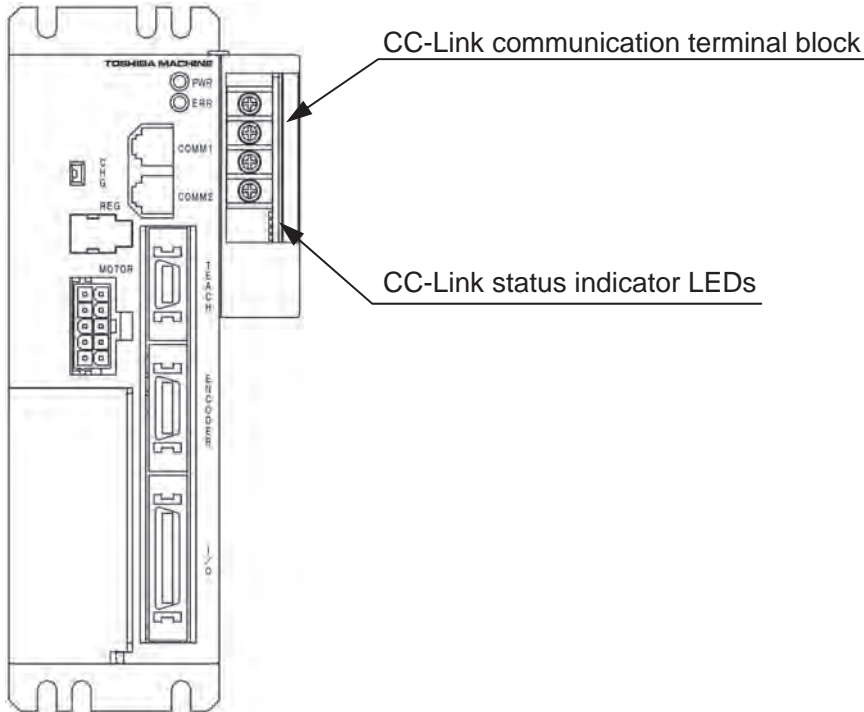

[CC-Link Status Indicator LEDs]

LED name	Color	On/Off	Description
RD	Green	On	During data reception
		Off	When not receiving data
SD	Green	On	During data sending
		Off	When not sending data
ERR	Red	On	CRC error, abnormal speed, invalid station number setting
		Off	During normal operation
RUN	Green	On	During normal operation
		Off	During timeout or network stoppage

CC-Link status indicator LEDs

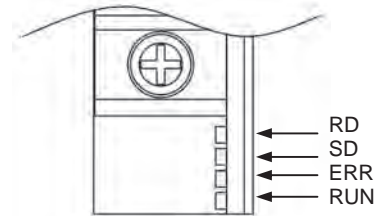

[CC-Link Communication Terminal Block]

This is a terminal block for connecting the dedicated CC-Link cable for data linkage.

Pin no.	Signal name	Wire color
1	Communication wire (DA)	Blue
2	Communication wire (DB)	White
3	Digital ground (DG)	Yellow
4	Shield (SLD)	Shield

CC-Link communication terminal block

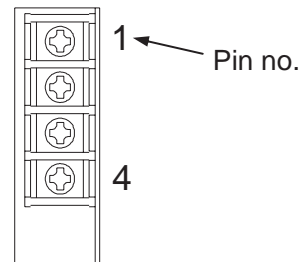

DeviceNet Unit

DeviceNet is a field network interface that enables reduced wiring, lower costs, and high-speed data communication. The DeviceNet interface can be used to perform various input/output and data communication for the jog operation.

Note: This cannot be installed by the customer.

[Code designation]

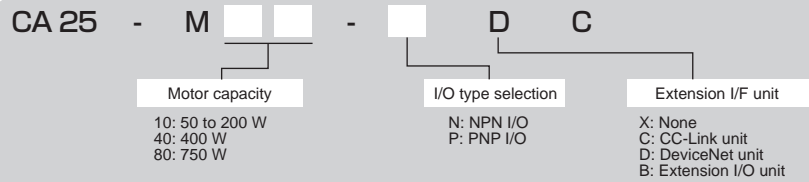

CA25-M10-DC

[Interface Specifications]

Item	Specifications		
Communication protocol	Compliant with DeviceNet		
Support connection	I/O connection (polling)		
Baud rate	125k, 250k, 500kbps (set by parameters)		
Station number setting	0 to 63 (set by parameters)		
Cable length	Baud rate	Thick cable	Narrow cable
	125k	500m	100m
	250k	250m	
	500k	100m	
Number of occupied stations	Sending: 128 points, Receiving: 128 points		
Number of inputs/outputs (*1)	4 system inputs, 4 system outputs		
	64 general-purpose inputs, 64 general-purpose outputs		
	8 jog inputs, 8 jog outputs		
Vendor ID	733 (TOSHIBA-MACHINE CO.,LTD.)		
Device type	0 (Generic Device)		
Product code	11 (CA25-M10-DC)		

*1) These are the inputs and outputs as seen from the robot controller.

[I/O Signal List]

Signal direction DeviceNet master station <- CA25-M10-*DC		Signal direction DeviceNet master station --> CA25-M10-*DC (*1)	
Input device no. (offset *2)	Signal name	Output device no. (offset *2)	Signal name
+0	Output during operation	+0	Home return input
+1	Error output	+1	Start input
+2	Positioning complete output	+2	Stop input
+3	Home return complete output	+3	Reset input
+4 to +7	Usage prohibited	+4 to +7	Usage prohibited
+8 to +15	General-purpose output port 1-1 to 8	+8 to +15	General-purpose input port 1-1 to 8
+16 to +23	General-purpose output port 2-1 to 8	+16 to +23	General-purpose input port 2-1 to 8
+24 to +31	General-purpose output port 3-1 to 8	+24 to +31	General-purpose input port 3-1 to 8
+32 to +39	General-purpose output port 4-1 to 8	+32 to +39	General-purpose input port 4-1 to 8
+40 to +47	General-purpose output port 5-1 to 8	+40 to +47	General-purpose input port 5-1 to 8
+48 to +55	General-purpose output port 6-1 to 8	+48 to +55	General-purpose input port 6-1 to 8
+56 to +63	General-purpose output port 7-1 to 8	+56 to +63	General-purpose input port 7-1 to 8
+64 to +71	General-purpose output port 8-1 to 8	+64 to +71	General-purpose input port 8-1 to 8
+72 to +79	Jog output	+72 to +79	Jog input
+80 to +127	Reserved (*3)	+80 to +127	Reserved (*3)



*1) When DeviceNet communication is cut off, the stop input is set to 1, and it is cleared to 0 in all other situations. The stop input is also cleared to 0 during teach pendant operation.

*2) Offset amount from the starting device (unit: bits)

*3) Reserved area for future function expansion (The setting should be fixed at 0.)

[DeviceNet Parts]

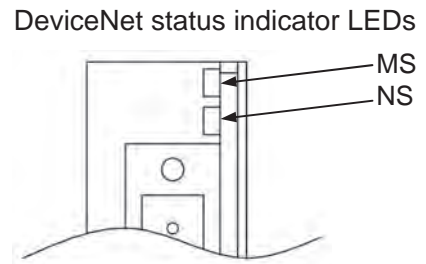
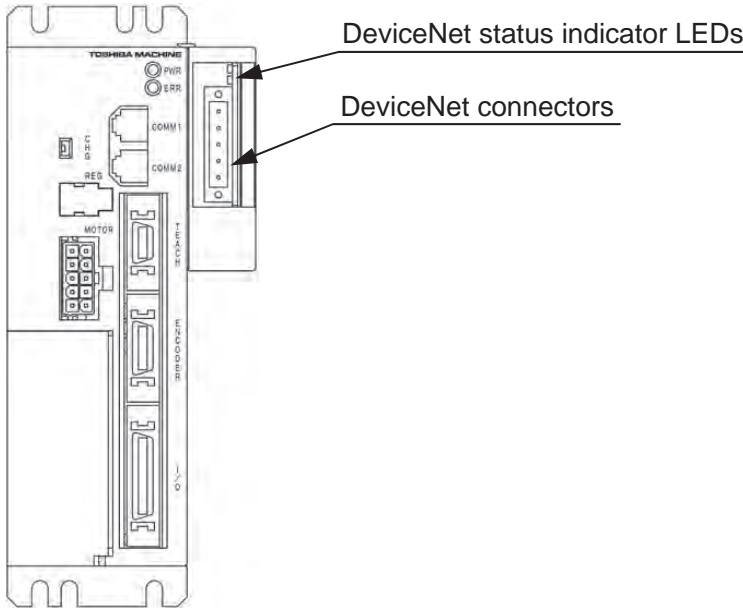

[DeviceNet Status Indicator LEDs]

LED name	Color	On/Off		Cause/Corrective action
MS	Green	● On	Normal	Normal status
		★ Flashing	Unset status	This indicates an error in the CA25-M10 setting values. Check the settings and restart. This can also indicate standby mode. Check if the master unit has started normally.
	Red	● On	Critical error	A hardware error has occurred. (DPRAM, internal ROM, internal RAM, EEPROM, CAN error, WDT error, etc.) Restart. If the error occurs again, replace the unit.
		★ Flashing	Minor error	The user settings are invalid, and a user-side interrupt timeout has occurred. Check and correct the settings, and then restart.
	—	○ Off	No power supply	No power is being supplied, or initialization or other process is in progress. Check the power supply.
NS	Green	● On	Normal	One or more connections is established (running) in an online state.
		★ Flashing	Standing by for connection	The master unit did not start normally. (This also includes a master unit I/O area configuration error.) Check whether the master unit has started normally.
	Red	● On	Critical communication error	A communication error has occurred (duplication of node address, busoff detection, baud rate mismatch, etc.). Check the connection status, noise, node address settings, baud rate settings, and other parameters, and then restart.
		★ Flashing	Minor communication error	Communication with the master unit has timed out. Check the status of the master unit and the connection status, noise, node address settings, baud rate settings, and other parameters, and then restart.
	—	○ Off	No power supply	Either no power is being supplied, or a WDT error occurred, a baud rate check is being performed, or a node address duplication check is being performed. Check the power supply.

*In ★ LED flashing, the LED repeats 0.5 seconds on and 0.5 seconds off.

[DeviceNet Connectors]

This is a connector for connecting the dedicated DeviceNet cable for data linkage. The connector is provided with this controller.

Pin no.	Signal name	Symbol	Wire color
5	V+	V+	Red
4	CANH	CH	White
3	Shield	dr	Shield
2	CANL	CL	Blue
1	V-	V-	Black

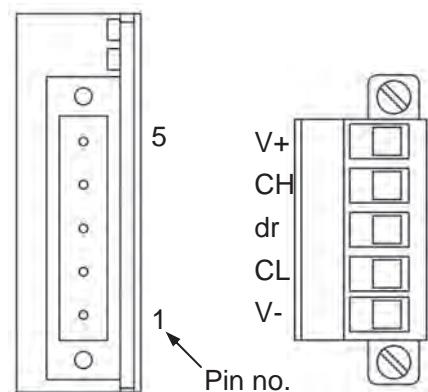

Controller

Regenerative Discharge Unit

[Application]

This unit is designed to absorb excess electrical energy generated in an axis motor during deceleration by resistors within the regenerative discharge unit. The unit is useful when the load inertia exceeds the tolerance, or when a heavy load is lowered along the Z-axis over a long stroke (generating excessive electricity).

(The regenerative discharge unit prevents an overvoltage from being generated in the controller.)

[CA25 Regenerative Discharge Unit Model]

[Code designation]

ABSU - 0 0 0

Motor capacity

2: 50 to 200 W (Applicable controllers: CA25-M10, CA25-S10)
 4: 400 W (Applicable controllers: CA25-M40, CA25-S40)
 8: 750 W (Applicable controllers: CA25-M80, CA25-S80)

[Specifications]

Item		Description		
Model		ABSU-2000	ABSU-4000	ABSU-8000
Regenerative operation voltage		420 V DC	390 V DC	421 V DC
Applicable controllers		CA25-M10, CA25-S10	CA25-M40, CA25-S40	CA25-M80, CA25-S80
Cooling method		Ambient cooling method	Forced air cooling method (using cooling fan)	
Cooling fan specifications		—	24 V DC, 0.19 A Brushless DC motor	24 V DC, 0.1 A Brushless DC motor
Protection functions		Thermal relay activated at discharge resistor temperature of 150°C Output contact: NC (normally closed) Contact capacity: 125 V AC / 4 A, 250 V AC / 4 A		Thermal relay activated at discharge resistor temperature of 150°C Output contact: 1b Contact capacity: 125 V AC / 6 A, 250 V AC / 3 A
Ambient conditions	Installation location	Indoor		
	Operating temperature range	0°C to 40°C		
	Operating humidity range	30% to 90% RH (no condensation)		
	Storage temperature range	-20°C to 70°C		
	Storage humidity range	30% to 90% RH (no condensation)		
	Environment	Indoor (not exposed to direct sunlight) 1000 m or less above sea level Location not exposed to dust, dirt, corrosive gases, or flammable gases		
	Vibrations	9.8 m/s ² or less		
Dimensions		55 (W)×160 (H)×122 (D) (Not including mounting fixtures)	80 (W)×189 (H)×122 (D) Including cooling fan (Not including mounting fixtures)	95 (W)×200 (H)×169 (D) Including cooling fan
Weight		0.78kg	0.94kg	2.9kg

Notes

- If the regenerative discharge unit is used by in combination with a controller other than the applicable controllers listed here, it may break down or fail to operate.

[Dimensional Diagrams]

ABSU-2000

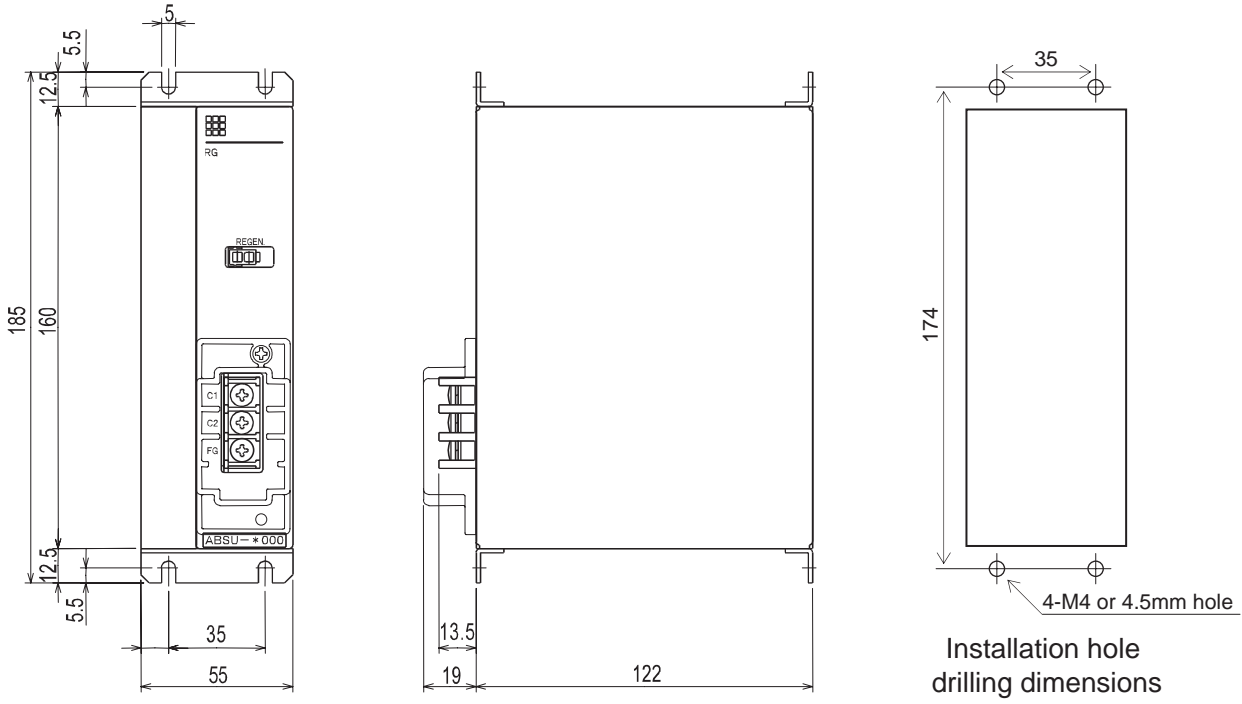

ABSU-4000

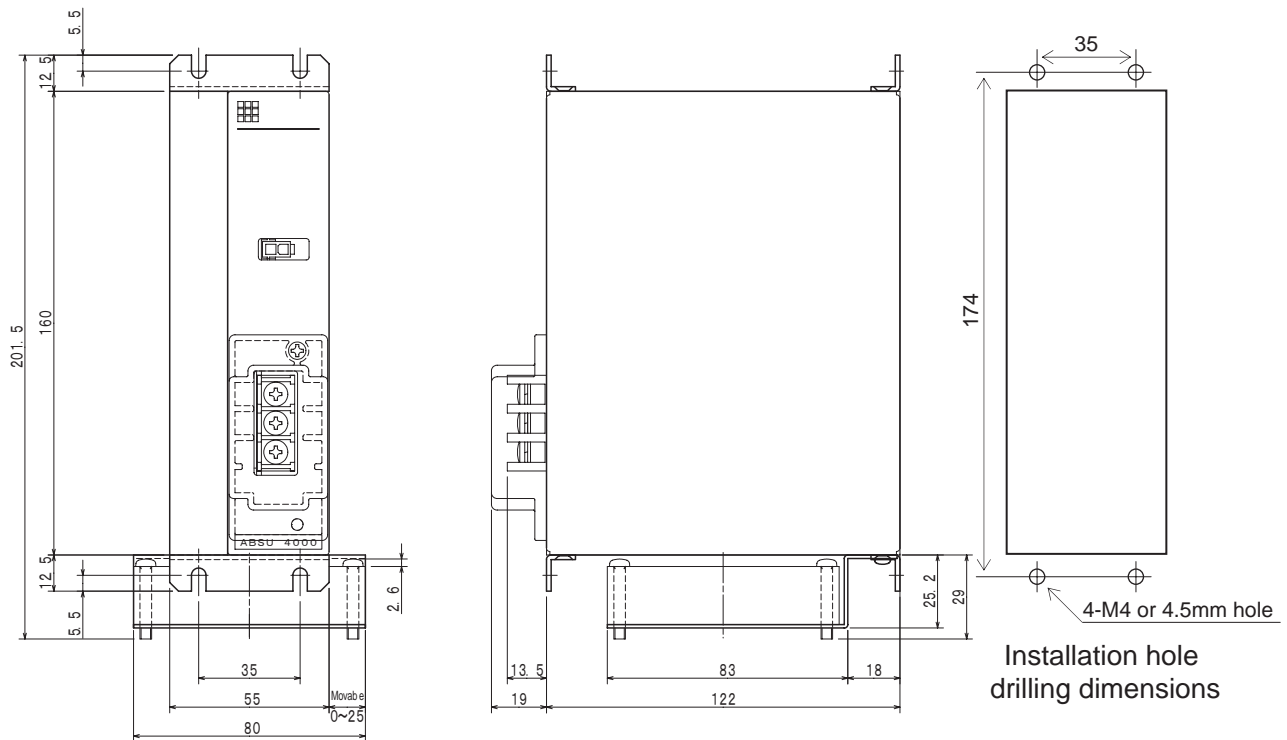

Controller

[Regenerative Discharge Unit for BAC and Discharge Resistor Models]

[Code designation]

CAR - 0500
 CAR - UN50

[Specifications]

Item	Description	
Model	CAR-0500	CAR-UN50
Type	Resistor	Unit
Regenerative operation voltage	48 V DC (controlled by controller)	
Cooling method	Natural air cooling	
Protection functions	Thermal relay activated at internal resistor temperature of 135°C Output contact: 1b Maximum switching voltage: 250 V AC / 42 V DC Maximum switching current: 0.2 A AC/DC (Minimum switching current: 1 mA AC/DC)	Thermal relay activated at unit surface temperature of 120°C Output contact: 1b Maximum switching voltage: 110 V AC/DC Maximum switching current: 0.3 A AC/DC Maximum switching power: 6 W AC/DC (Minimum switching current: 0.1 mA/1 V DC)
Ambient conditions	Operating temperature range	0°C to 40°C
	Operating humidity range	30% to 90% RH (no condensation)
	Storage temperature range	-20°C to 70°C
	Storage humidity range	30% to 90% RH (no condensation)
	Environment	Indoor (not exposed to direct sunlight) 1000 m or less above sea level Location not exposed to dust, dirt, corrosive gases, or flammable gases
	Vibrations	4.9 m/s ² or less
Dimensions	30(W)×130(H)×60(D)	30(W)×146(H)×88(D)
Weight	0.39kg	0.22kg

[Dimensional Diagrams]

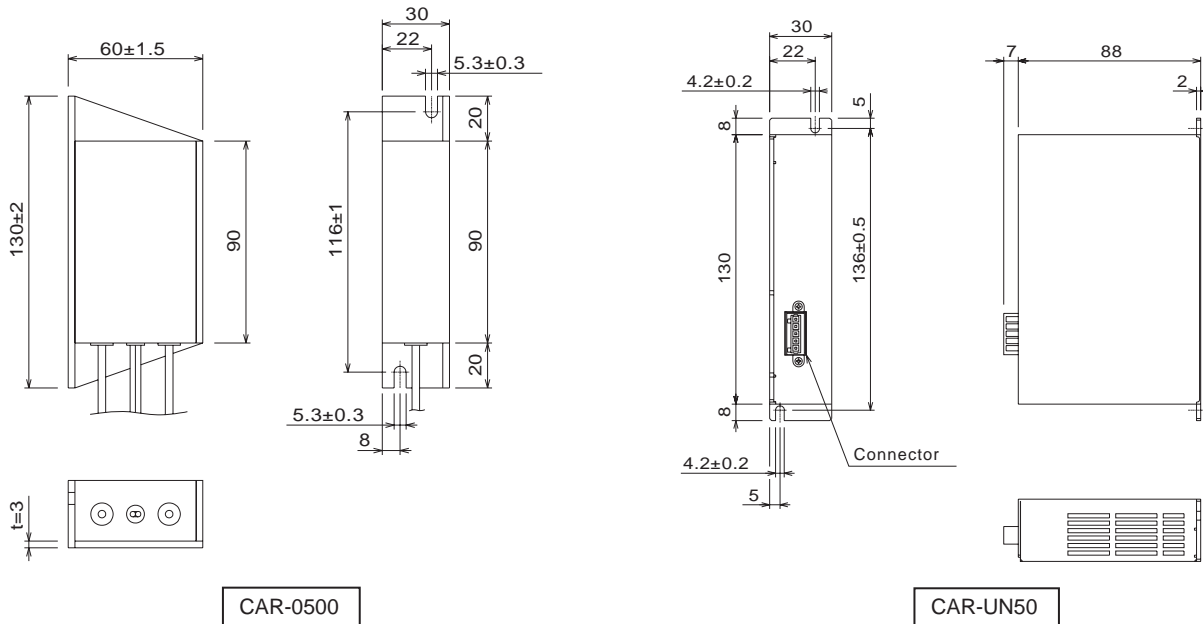

Controller

[Connection Example]

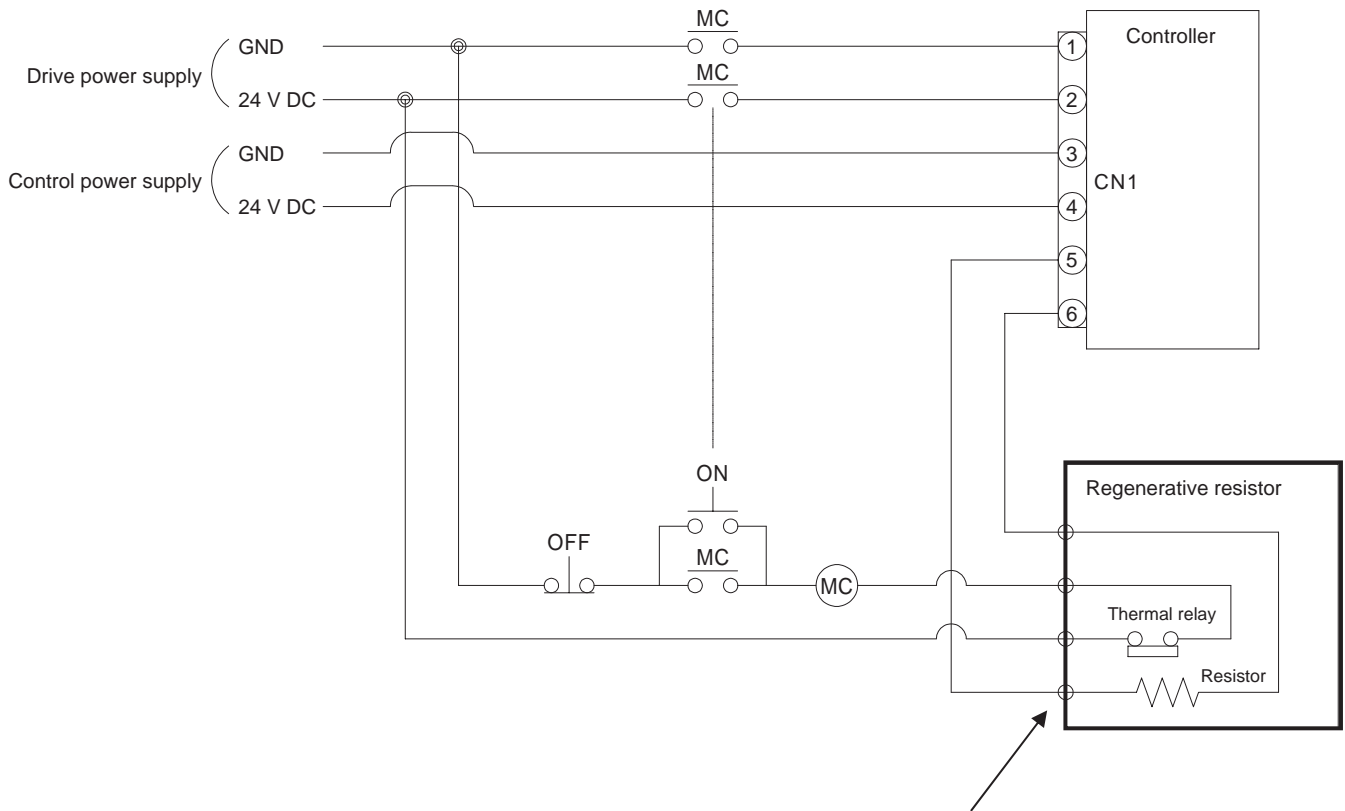

* For the unit type, the connection is made using a connector.

- Usage Notes

- A built-in thermal relay which activates at a temperature of 135°C is used in the CAR-0500 and which activates at a temperature of 120°C is used in the CAR-UN50.
- When this relay is activated, the thermal relay output connections are opened.
- Be sure to incorporate a sequence so that the controller drive power always turns off when the thermal relay is activated.
- Once the thermal relay is activated, it takes about three minutes for it to reset (return to normal status).

Teach Pendant

[Application]

When the teach pendant is connected to a controller, it can be used for input of programs and parameters and also issue commands to execute home return, start, stop, jog, emergency stop, and other operations. The teach pendant can also be used to display error messages and clear errors and faults that have occurred.

[Code designation]

TPH - 4C

[Supported Controllers]

CA25-M10, CA25-M40, CA25-M80, CA01-M05
Previous models: CA10 series, CA20 series

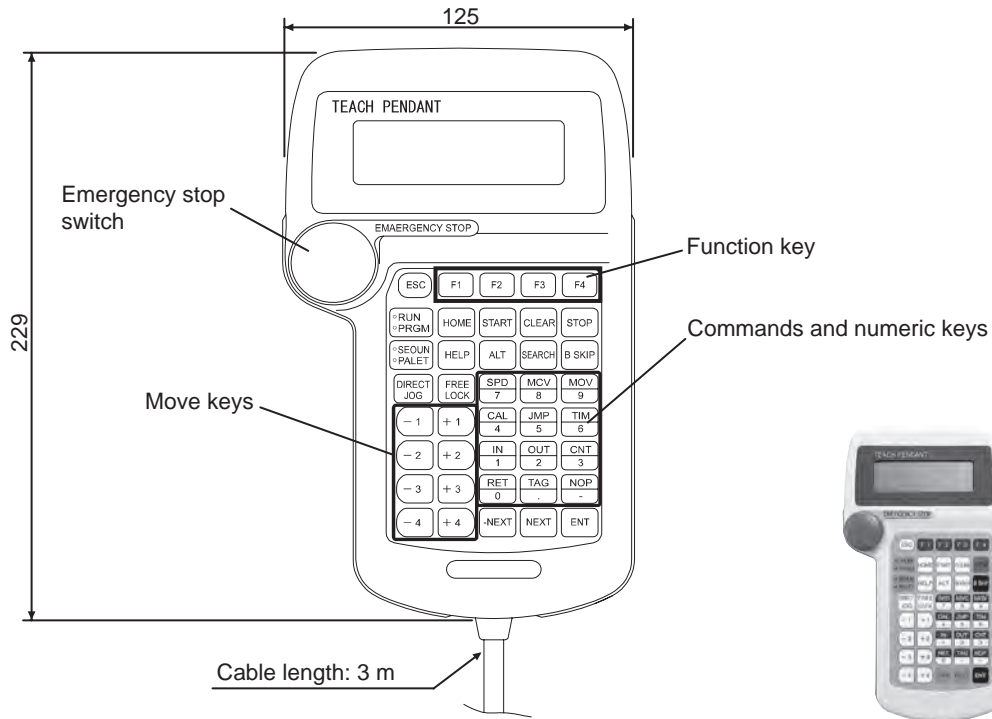

Model: TPH-4C

Note: Version 2.26 or higher is supported in the CA25 series.

Link Cable

[Application]

This cable is used for communication between the master unit serving as the main controller and the slave unit which operates under commands issued by the main controller.

The cable is not required when the master unit only is used in single-axis control.

The link cable is connected from the master unit to the slave unit in series.

The cable length can be selected based on whether the master and slave units are installed near to or far from each other.

[Code designation]

CA10 - LC - A 01

Link cable

Cable length
01: 150 mm
03: 300 mm
10: 1000 mm

Version not written

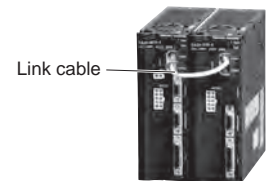

Controller

*The link cable must not be bundled together with other signal cables, and it must not be housed in the same wire duct as other signal cables.
*The link cable has plugs on both ends. It cannot be cut or modified.

[Dimensional Diagrams]

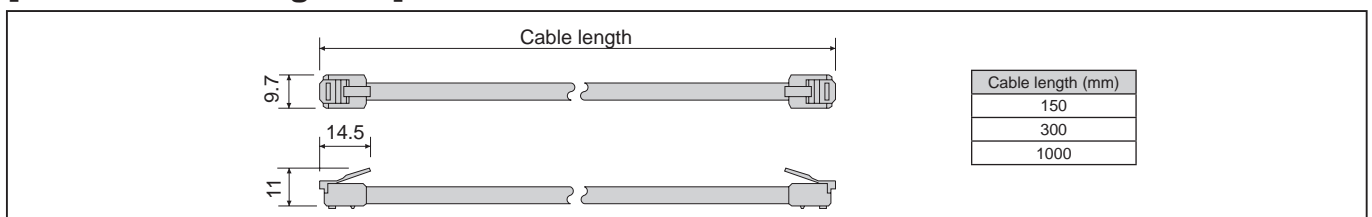

I/O Cable

[Application]

This is used to connect a controller (master unit or slave unit) or an I/O port of an extension I/O unit to transmit signals to an external operation panel or control device.
 A plug is attached at one end of the cable, which can be connected directly to the controller.
 The I/O cable should be connected to the external device based on the color marking on the cable core leads and the sign table.
 Before connecting to an external device, a crimp terminal should be added to the cable core leads.



[Code designation]

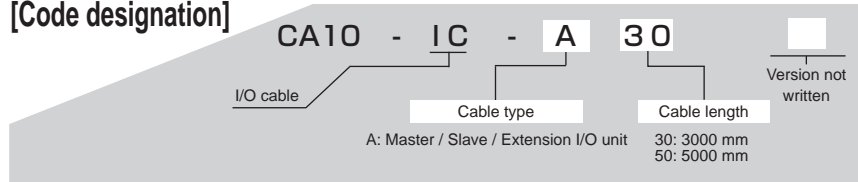

[Connection Units]

CA25-M10, CA25-M40, CA25-M80,
 CA25-S10, CA25-S40, CA25-S80,
 extension I/O unit

[Dimensional Diagram]

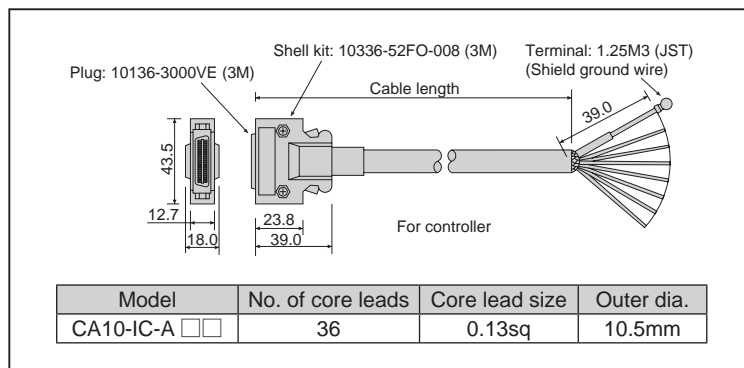

* A shielded cable is used for improving the noise resistance of the I/O cable. Ground the shield wire as required.
 * The I/O cable does not have bending resistance.

PC Software

[Application]

The PC software SF-98D has been developed to support program creation by using a personal computer as the host computer.

This software can be used to receive, send, edit, and save the program data in the robot controller to the PC, monitor the I/O status and coordinate values, execute programs, and execute and control the jog, home return, and other operations.

This software is also ideal for debugging and maintenance.

[Code designation]

S F - 9 8 D
Version

[Supported Controllers]

CA25-M10, CA25-M40, CA25-M80, CA01-M05
Previous models: CA10 series, CA20 series

[Specifications]

Package contents		CD-ROM x 1 (Communication cable PCBL-31 is sold separately.)
Required system configuration	PC	Serial communication port (D-Sub 9-pin), IBM PC/AT compatible computer equipped with CD-ROM drive Available memory space: 12 MB or more, Available hard disk space: 10 MB or more
	Operating system (OS)	Microsoft Windows XP, Windows Vista, or Windows 7
	Display	SVGA or higher (resolution of 800 x 600 pixels or higher)
	Printer	Printer that can be connected to your computer and is capable of printing from Windows
	Communication cable	This cable is used to connect the PC and controller. Use the PCBL-31.
Compatible controllers		CA25-M10, CA25-M40, CA25-M80 *, CA01-M05, Previous models: CA10 series, CA20 series

Microsoft Windows and the Windows logo are trademarks or registered trademarks of Microsoft Corporation (U.S.).

*1) Version 3.1.0 or higher is supported in the CA25 series.

[Features]

- This software can be used on PCs running the Microsoft Windows XP, Windows Vista, or Windows 7.
- Programs can easily be edited using the multi-window screen editor.
- Programs and table data can be sent to and received from the robot controller. This data can also be saved as a file on the PC.
- Axis operations can be controlled by teaching or program execution.
- A title and comments (notes) can be added to a program when printing it (output to printer), and so this software is useful for debugging and data confirmation.
- Files that were saved for previous models (CA10 series and CA20 series) can be converted to CA25 series compatible files.

- Editing screen for sequential program



- Editing screen for coordinate table

CSV-format files created in Excel and other spreadsheet programs can also be imported.

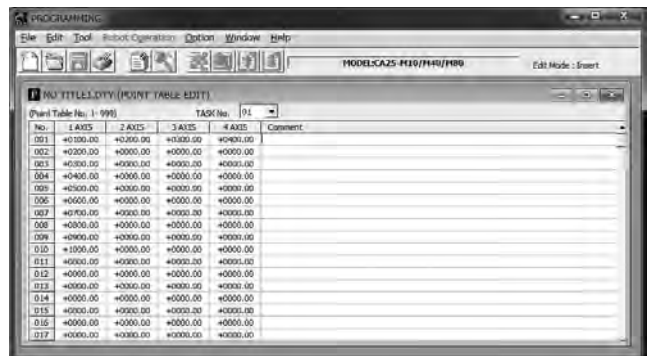

- Robot operation screen

Operations such as program execution and jog motion, which are the same as in the teach pendant, are possible.

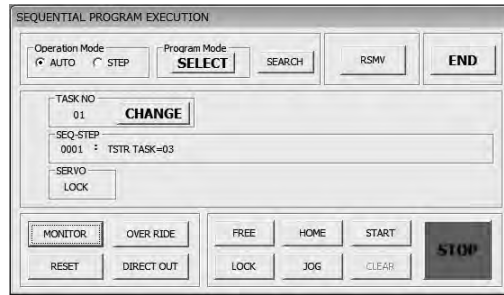
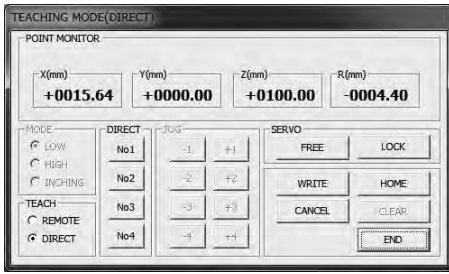

- Monitor screen

Current position coordinates, I/O port status can be monitored.

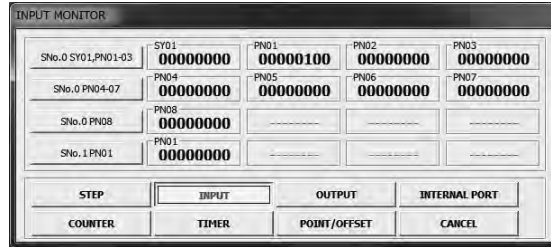
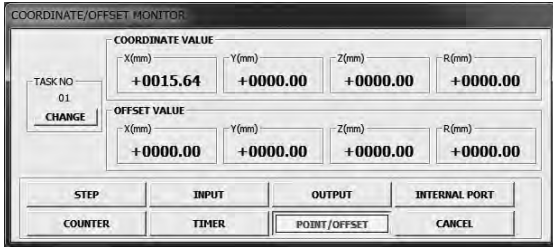

[Connections]

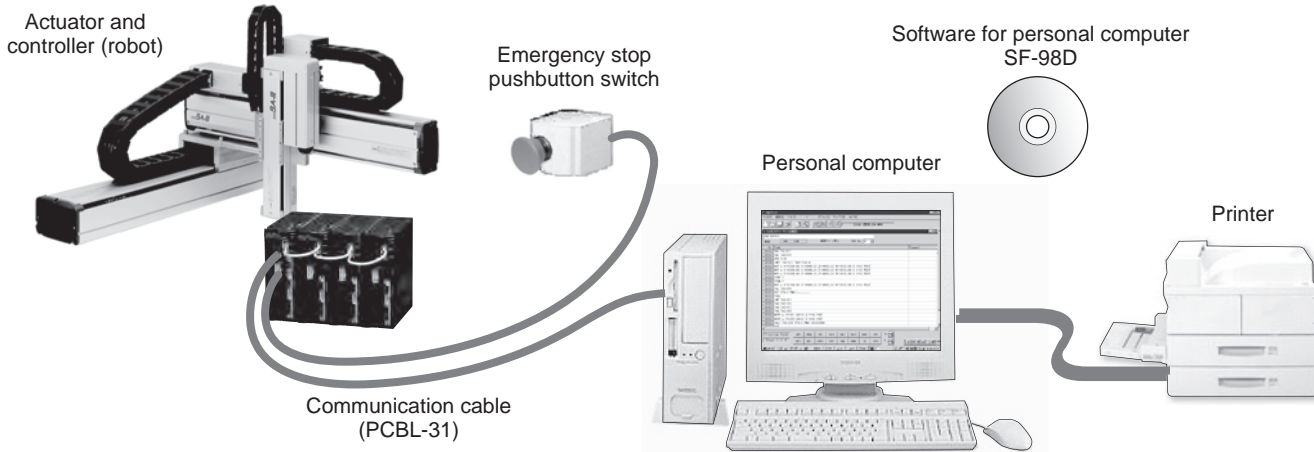

Controller

Communication cable (RS232C)

[Application]

This cable connects the controller and personal computer (IBM/PC compatible). It is used when using the software for personal compute.

[Code designation]

PCBL - 31

[Dimensions]

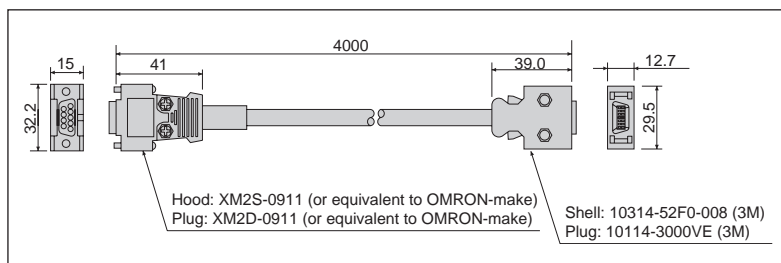

Lithium Battery for Encoder Back-up

[Application]

This is a battery that is installed in the controller as a back-up power source for the absolute encoder. In the standard configuration, one battery each is supplied with the master units CA25-M10, CA25-M40, CA25-M80, and slave units CA25-S10, CA25-S50, and CA25-S80. Use them for replacement or as spares.

[Code designation]

CA25 - EB - 05

[Specifications]

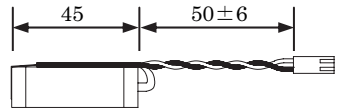
Item		Description	Remarks	
Part name		Lithium battery	Lithium-thionyl chloride (Li-SOCl ₂) battery	
Model		CA25-EB-05	Battery unit: ER6C (made by Hitachi Maxell)	
Specifications	Nominal voltage, capacity	3.6V 1800mAh		
	Dimensions	Battery unit		14.5 mm diameter x 45 mm (excluding protrusions)
		Harness length		50±6 mm (excluding connectors)
Weight		Approx. 14.5 kg		
Back-up duration (*1)		Approx. 3 years (*2)	25°C, Back-up current: 65 µA	

Notes

*1: This is the cumulative time that the controller power is turned off.

*2: The battery duration varies depending on the ambient temperature and other conditions. This figure is provided as an approximate guideline only.

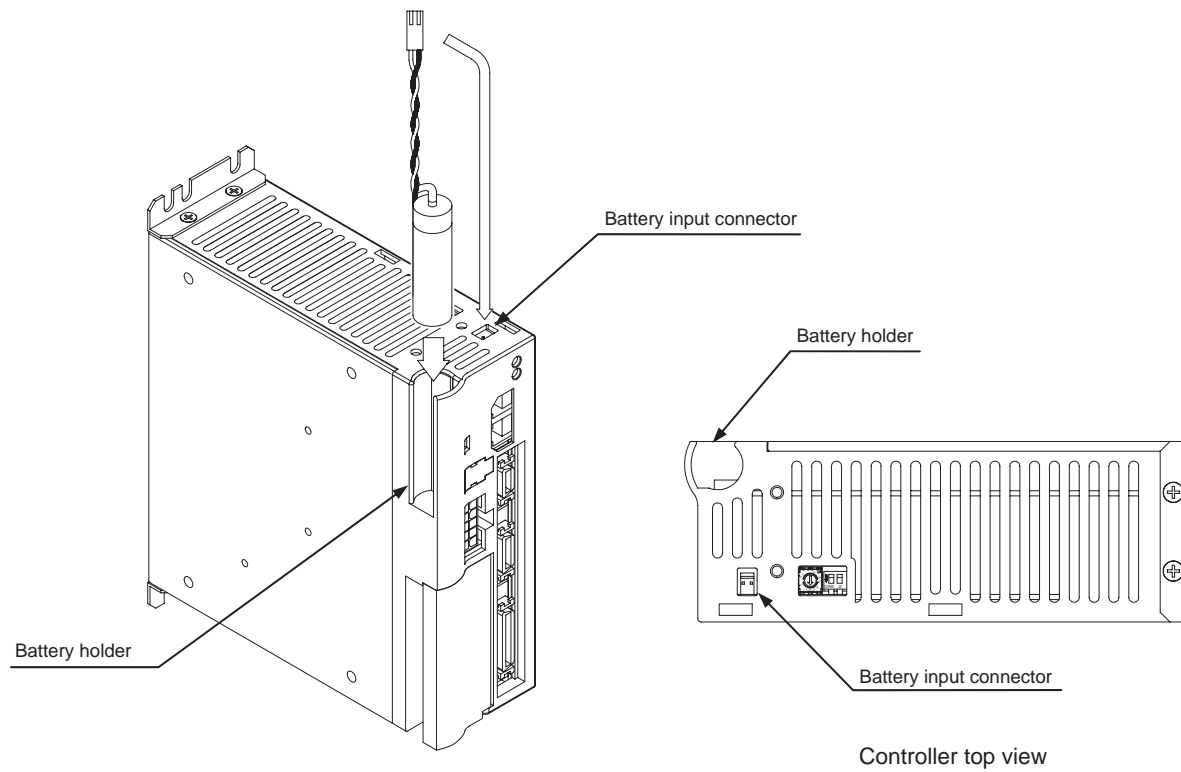

Technical Notes

Actuator

Service Life of Guide198

Allowable Load Moment

1. Allowable Static Load Moment198

2. Allowable Dynamic Load Moment198

Components of Control System

Operation Mode207

Details of Input and Output, and Example
Connection

• CA25-M10, M40, M80210

• CA25-S10, S40, S80220

How to Calculate Tact (Cycle) Time222

Service Life of Guide

The maximum payload and allowable load moment given in this manual are the values calculated based on the following service life of guide.

They are commonly used for both ball-screw driven and timing-belt driven axes of each axis type.

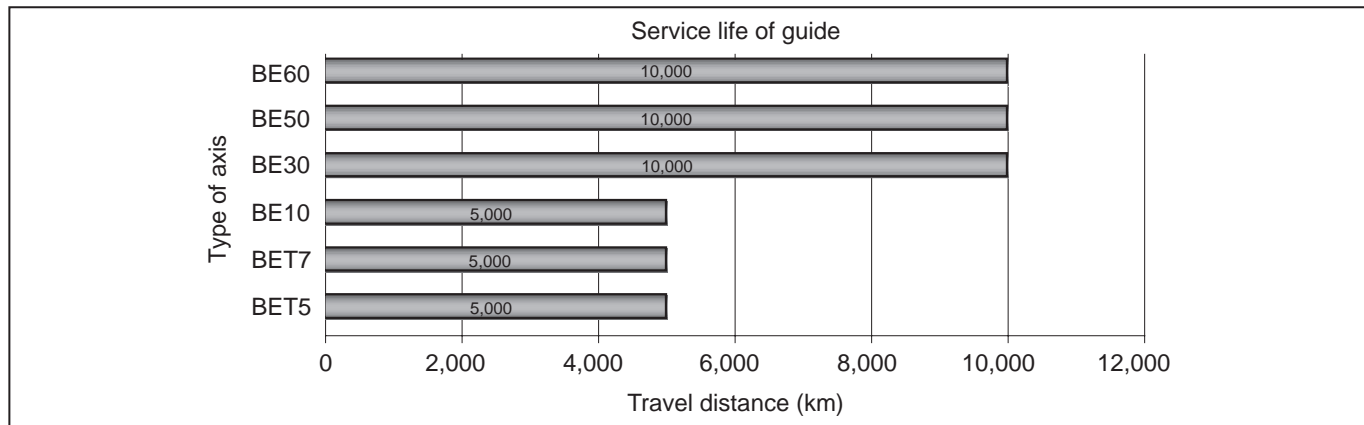

Allowable Load Moment

As the moment caused by a load imposed on the actuator largely affects the slider bearing unit, the following matters should be considered at use.

- ◆ A load exceeding the maximum payload should not be applied.
This value can be determined based on the servo motor capacity and differs with the acceleration/deceleration time.
- ◆ The moment should not exceed the allowable static load moment.
This is the moment caused during stoppage. For insertion work by using a cylinder attached to the slider, reaction force should be considered. Impact load MUST NOT be exerted.
- ◆ The moment should not exceed the allowable dynamic load moment.
This is the moment caused by acceleration or deceleration.
The value varies with the load, arm length, direction, etc. Refer to the value given in the table below as a yardstick.

Both the allowable static load moment and allowable dynamic load moment are described below. For the maximum payload, see the specifications of each actuator.

1. Allowable Static Load Moment

- MR: Rolling moment
- MP: Pitching moment
- MY: Yawing moment

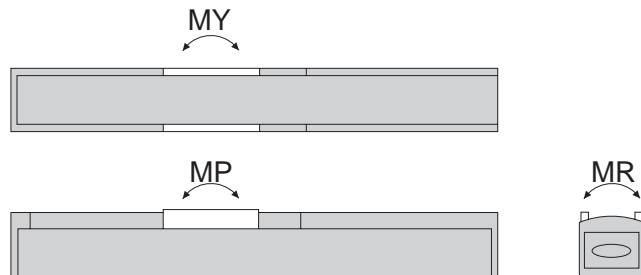

Allowable static load moment N·m	MR								MP						MY						
	BET5	BET7	BE10	BE30	BE50	BE60G	BE60J	BET5	BET7	BE10	BE30	BE50	BE60G	BE60J	BET5	BET7	BE10	BE30	BE50	BE60G	BE60J
Short slider (S)	-	-	49	-	-	-	-	-	-	14	-	-	-	-	-	-	13	-	-	-	-
Medium slider (M)	31	58	59	510	2080	2700	3500	31	25.7	59	430	2160	3000	4000	12	25.7	54	370	1820	2250	3000
Long slider (L)	-	-	-	510	2080	2700	3500	-	-	-	750	3150	4750	6200	-	-	-	650	2640	3450	4750

2. Allowable Dynamic Load Moment

The dynamic load moment of an actuator largely influences its life and performance. The allowable dynamic load moment should be calculated, considering the acceleration/deceleration time, (acceleration), load, arm length, direction, speed, stroke, etc., based on the allowable moment of bearing.

Given in the following pages are the tables of allowable dynamic load moment tabulating the load and allowable arm length so that the allowable dynamic load moment can be obtained easily.

Load mass (W kg) and arm length up to the center of gravity of the load (L mm) are shown in each table. (They are not the values of allowable load moment.)

Notes

- The calculation of the value of the distance to the load written for the allowable dynamic load moment does not include the rigidity of the tool mounted to the axis unit slider or the fluctuation due to the rigidity of the axis body. In certain cases, the fluctuation is so large that the operation cannot be performed or the required specifications are not satisfied.
- The axis body in a Cartesian robot is subject to displacement (torsion, deflection, etc.) due to the load and its own weight. For cases where straightness or other conditions are required, reinforcement of the strength of the frame and the axis body of the combination axis may be necessary.

[Table of allowable dynamic load moment] BET5, BET7

Load mass (W kg) and arm length up to the center of gravity of the load (L mm) are shown in each table. (They are not the values of allowable load moment.)

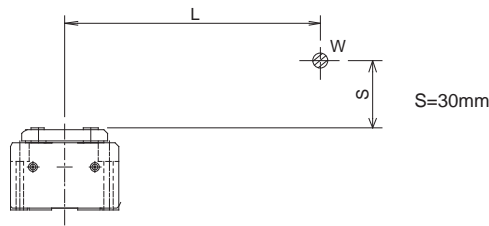

[Mounted horizontally]

BET5	Lead 12										Lead 6				
W [kg]	0.5	1	1.5	2	2.5	3	3.5	4	4.5	5	6	7	8	9	10
L [mm]	1540	760	500	370	290	240	210	175	150	135	130	120	100	90	80

★ Speed Lead 12: 800 mm/s, Lead 6: 400 mm/s (when using a stroke of 450 mm or less) Acceleration/deceleration time: 0.3 sec

BET7	Lead 12										Lead 6										
W [kg]	1	2	3	4	5	6	7	8	9	10	11	12	14	16	18	20	22	24	26	28	30
L [mm]	2395	1180	775	575	455	370	315	270	235	210	185	170	165	160	150	130	120	105	95	85	80

★ Speed Lead 12: 800 mm/s, Lead 6: 400 mm/s (when using a stroke of 550 mm or less) Acceleration/deceleration time: 0.3 sec

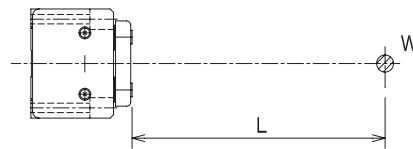

[Mounted horizontally] Wall-mounted

BET5	Lead 12										Lead 6				
W [kg]	0.5	1	1.5	2	2.5	3	3.5	4	4.5	5	6	7	8	9	10
L [mm]	1600	780	505	365	285	230	190	160	140	120	110	85	70	55	45

★ Speed Lead 12: 800 mm/s, Lead 6: 400 mm/s (when using a stroke of 450 mm or less) Acceleration/deceleration time: 0.3 sec

BET7	Lead 12										Lead 6										
W [kg]	1	2	3	4	5	6	7	8	9	10	11	12	14	16	18	20	22	24	26	28	30
L [mm]	2460	1200	780	570	445	360	300	255	220	195	170	150	140	130	110	90	75	65	55	45	35

★ Speed Lead 12: 800 mm/s, Lead 6: 400 mm/s (when using a stroke of 550 mm or less) Acceleration/deceleration time: 0.3 sec

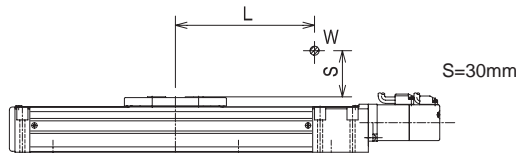

[Mounted horizontally]

BET5	Lead 12										Lead 6				
W [kg]	0.5	1	1.5	2	2.5	3	3.5	4	4.5	5	6	7	8	9	10
L [mm]	795	395	260	195	150	125	105	90	80	70	60	50	40	35	30

★ Speed Lead 12: 800 mm/s, Lead 6: 400 mm/s (when using a stroke of 450 mm or less) Acceleration/deceleration time: 0.3 sec

BET7	Lead 12										Lead 6										
W [kg]	1	2	3	4	5	6	7	8	9	10	11	12	14	16	18	20	22	24	26	28	30
L [mm]	990	490	325	240	190	155	135	115	100	92	82	75	65	57	49	43	39	35	31	29	27

★ Speed Lead 12: 800 mm/s, Lead 6: 400 mm/s (when using a stroke of 550 mm or less) Acceleration/deceleration time: 0.3 sec

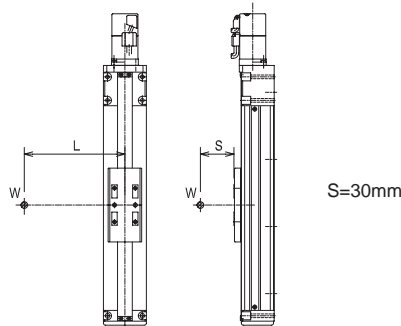

[Mounted vertically]

BE05	Lead 12			Lead 6		
W [kg]	0.5	1	1.5	2	2.5	3
L [mm]	720	335	205	150	110	70

★ Speed Lead 12: 800 mm/s, Lead 6: 400 mm/s (when using a stroke of 450 mm or less) Acceleration/deceleration time: 0.3 sec

BE07	Lead 12				Lead 6			
W [kg]	1	2	3	4	5	6	7	8
L [mm]	915	435	275	195	160	130	105	85

★ Speed Lead 12: 800 mm/s, Lead 6: 400 mm/s (when using a stroke of 550 mm or less) Acceleration/deceleration time: 0.3 sec

[Mounted vertically]

BE05	Lead 12			Lead 6		
W [kg]	0.5	1	1.5	2	2.5	3
L [mm]	750	365	235	180	140	110

★ Speed Lead 12: 800 mm/s, Lead 6: 400 mm/s (when using a stroke of 450 mm or less) Acceleration/deceleration time: 0.3 sec

BE07	Lead 12				Lead 6			
W [kg]	1	2	3	4	5	6	7	8
L [mm]	920	440	285	205	160	130	105	85

★ Speed Lead 12: 800 mm/s, Lead 6: 400 mm/s (when using a stroke of 550 mm or less) Acceleration/deceleration time: 0.3 sec

[Table of allowable dynamic load moment] BE10, BE30, BE50, BE60

Load type I [Mounted horizontally]



When S = 50 mm:

Arm length up to the center of gravity of load: L

(mm)

Drive system	Actuator	Speed (mm/s)	Lead (mm)	Slider	Load: W															
					5Kg	10Kg	15Kg	20Kg	25Kg	30Kg	35Kg	40Kg	45Kg	50Kg	55Kg	60Kg	65Kg	70Kg	75Kg	80Kg
Ball screw	BE10E	1200	20	S	375	175	105	-	-	-	-	-	-	-	-	-	-	-	-	
				M	700	355	240	-	-	-	-	-	-	-	-	-	-	-	-	-
		600	10	S	560	270	180	135	110	90	-	-	-	-	-	-	-	-	-	-
				M	810	395	270	205	167	140	-	-	-	-	-	-	-	-	-	-
		300	5	S	615	320	210	160	140	110	97	85	77	70	-	-	-	-	-	-
				M	820	405	275	210	172	145	120	100	87	75	-	-	-	-	-	-
	BE30E	1200	20	M	1182	590	410	315	-	-	-	-	-	-	-	-	-	-	-	-
				L	1342	670	467	360	-	-	-	-	-	-	-	-	-	-	-	-
		600 (300)	10 (5)	M	1480	740	515	400	330	285	252	215	185	160	-	-	-	-	-	-
				L	1542	775	537	415	347	300	262	225	192	165	-	-	-	-	-	-
	BE30F	1200	20	M	1135	590	410	315	260	225	200	165	-	-	-	-	-	-	-	-
				L	1290	670	465	360	300	260	230	195	-	-	-	-	-	-	-	-
		600 (300)	10 (5)	M	1425	740	515	400	330	285	252	215	185	160	140	120	110	95	85	75
				L	1485	775	535	415	345	300	265	225	190	165	145	125	110	100	90	80
	BE50F	1200	20	M	5320	2620	1720	1270	1000	820	690	595	520	460	410	370	-	-	-	-
				L	5545	2730	1795	1325	1040	855	720	620	540	480	430	385	-	-	-	-
		600 (300)	10 (5)	M	5875	2895	1900	1405	1105	905	765	655	575	510	455	410	370	335	310	285
				L	5945	2925	1920	1420	1115	815	770	665	580	515	460	415	375	340	315	290
	BE50G	1200	20	M	5320	2620	1720	1270	1000	820	690	595	520	460	410	370	335	305	280	255
				L	5545	2730	1795	1325	1040	855	720	620	540	480	430	385	350	320	290	265
		600 (300)	10 (5)	M	5875	2895	1900	1405	1105	905	765	655	575	510	455	410	370	335	310	285
				L	5945	2925	1920	1420	1115	815	770	665	580	515	460	415	375	340	315	290

★ The speed is applicable when axis stroke is 600 mm or less (acceleration/deceleration time: 0.36 sec).

(mm)

Drive system	Actuator	Speed (mm/s)	Lead (mm)	Slider	Load: W									
					85Kg	90Kg	95Kg	100Kg	110Kg	120Kg	130Kg	140Kg	150Kg	
Ball screw	BE50F	600 (300)	10 (5)	M	260	245	225	210	-	-	-	-	-	-
				L	270	245	230	210	-	-	-	-	-	
	BE50G	1200	20	M	235	215	200	185	-	-	-	-	-	
				L	245	230	210	195	-	-	-	-	-	
	600 (300)	10 (5)	M	260	245	225	210	180	160	140	125	110	-	
			L	270	245	230	210	185	160	140	125	110	-	

★ The speed is applicable when axis stroke is 600 mm or less (acceleration/deceleration time: 0.36 sec).

(mm)

Drive system	Actuator	Speed (mm/s)	Lead (mm)	Slider	Load: W [kg]																
					10	20	30	40	50	60	70	80	90	100	110	120	130	140	150		
Ball screw	BE60G	1200	20	M	7050	3450	2300	1700	1350	1100	950	800	700	650	-	-	-	-			
				L	7700	3800	2500	1850	1500	1200	1050	900	800	700	-	-	-	-			
		600	10	M	8400	4150	2750	2050	1600	1350	1150	950	850	750	700	600	550	500	500		
				L	8700	4300	2850	2100	1650	1350	1150	1000	900	800	700	650	600	550	500		

★ The speed is applicable when axis stroke is 700 mm or less (acceleration/deceleration time: 0.36 sec).

(mm)

Drive system	Actuator	Speed (mm/s)	Lead (mm)	Slider	Load: W [kg]														
					110	120	130	140	150	160	170	180	190	200	210	220	230	240	250
Ball screw	BE60J	900	20	M	800	700	700	600	500	500	500	400	400	400	-	-	-	-	
				L	800	800	700	600	600	500	500	500	400	400	-	-	-	-	
		450	10	M	900	800	700	700	600	600	500	500	500	400	400	400	400	400	300
				L	900	800	800	700	600	600	600	500	500	500	400	400	400	400	400

★ The speed is applicable when axis stroke is 1000 mm or less (acceleration/deceleration time: 0.27 sec).

(mm)

Drive system	Actuator	Speed (mm/s)	Lead (mm)	Slider	Load: W									
					5Kg	10Kg	15Kg	20Kg	25Kg	30Kg	35Kg	40Kg		
Timing belt	BE10E	1000	21	S	375	175	105	-	-	-	-	-	-	
				M	700	355	240	-	-	-	-	-		
	BE10F	1000	21	S	375	175	105	70	-	-	-	-		
				M	700	355	240	180	-	-	-	-		
	2000	42	S	112	52	-	-	-	-	-	-			
			M	210	106	-	-	-	-	-	-			
	BE30E	1000	21	M	1182	590	410	-	-	-	-	-		
				L	1342	670	467	-	-	-	-	-		
	BE30F	1000	21	M	1135	590	410	315	260	225	200	165		
				L	1290	670	465	360	300	260	230	195		
		2000	42	M	454	236	164	126	-	-	-	-		
				L	516	268	186	144	-	-	-	-		
	BE50F	1000	21	M	5320	2620	1720	1270	1000	850	690	595		
				L	5545	2730	1795	1325	1040	855	720	620		
	BE50G	2000	42	M	2128	1048	688	508	-	-	-	-		
				L	2218	1092	718	530	-	-	-	-		

★ The speed is applicable when the lead is 21 mm and acceleration/deceleration time is 0.3 sec, and when the lead is 42 mm and acceleration/deceleration time is 0.5 sec.

[Table of allowable dynamic load moment] BE10, BE30, BE50, BE60

When S = 200 mm:

Arm length up to the center of gravity of load: L

(mm)

Drive system	Actuator	Speed (mm/s)	Lead (mm)	Slider	Load: W																
					5Kg	10Kg	15Kg	20Kg	25Kg	30Kg	35Kg	40Kg	45Kg	50Kg	55Kg	60Kg	65Kg	70Kg	75Kg	80Kg	
Ball screw	BE10E	1200	20	S	310	105	-	-	-	-	-	-	-	-	-	-	-	-	-	-	
				M	690	340	220	-	-	-	-	-	-	-	-	-	-	-	-	-	-
		600	10	S	537	245	150	105	75	50	-	-	-	-	-	-	-	-	-	-	-
				M	790	390	265	200	165	135	-	-	-	-	-	-	-	-	-	-	-
		300	5	S	622	300	200	150	120	100	87	75	67	60	-	-	-	-	-	-	-
				M	820	405	275	210	172	145	120	100	87	75	-	-	-	-	-	-	-
	BE30E	1200	20	M	1180	585	400	305	-	-	-	-	-	-	-	-	-	-	-	-	
				L	1342	670	462	355	-	-	-	-	-	-	-	-	-	-	-	-	
		600 (300)	10 (5)	M	1480	740	515	395	330	280	250	215	180	155	-	-	-	-	-	-	
				L	1542	770	537	415	345	295	262	225	190	165	-	-	-	-	-	-	
	BE30F	1200	20	M	1135	585	400	305	225	185	155	130	-	-	-	-	-	-	-	-	
				L	1290	670	460	355	295	250	220	190	-	-	-	-	-	-	-	-	
		600 (300)	10 (5)	M	1425	740	510	395	330	280	250	215	180	155	135	120	105	90	80	70	
				L	1485	770	535	415	345	295	265	225	190	165	145	125	110	100	85	45	
	BE50F	1200	20	M	5320	2620	1720	1265	995	815	685	590	515	450	360	-	-	-	-	-	
				L	5545	2730	1790	1325	1040	855	720	615	540	475	425	380	-	-	-	-	
		600 (300)	10 (5)	M	5875	2895	1900	1400	1105	905	765	655	575	505	455	405	370	335	310	285	
				L	5945	2925	1920	1420	1115	915	770	665	580	515	460	415	375	340	310	285	
	BE50G	1200	20	M	5320	2620	1720	1265	995	815	685	590	515	450	400	360	325	295	270	245	
				L	5545	2730	1790	1325	1040	855	720	615	540	475	425	380	345	315	285	260	
		600 (300)	10 (5)	M	5785	2895	1900	1400	1105	905	765	655	575	505	455	405	370	335	310	285	
				L	5945	2925	1920	1420	1115	915	770	665	580	515	460	415	375	340	310	285	

★ The speed is applicable when axis stroke is 600 mm or less (acceleration/deceleration time: 0.36 sec).

(mm)

Drive system	Actuator	Speed (mm/s)	Lead (mm)	Slider	Load: W									
					85Kg	90Kg	95Kg	100Kg	110Kg	120Kg	130Kg	140Kg	150Kg	
Ball screw	BE50F	600 (300)	10 (5)	M	260	240	225	210	-	-	-	-	-	-
				L	265	245	225	210	-	-	-	-	-	
	BE50G	1200	20	M	225	205	190	175	-	-	-	-	-	
				L	240	220	205	190	-	-	-	-	-	
	BE50G	600 (300)	10 (5)	M	260	240	225	210	180	160	140	120	105	
				L	265	245	225	210	185	160	140	125	110	

★ The speed is applicable when axis stroke is 600 mm or less (acceleration/deceleration time: 0.36 sec).

(mm)

Drive system	Actuator	Speed (mm/s)	Lead (mm)	Slider	Load: W [kg]															
					10	20	30	40	50	60	70	80	90	100	110	120	130	140	150	
Ball screw	BE60G	1200	20	M	7050	3450	2300	1700	1350	1100	950	800	700	650						
				L	7700	3800	2500	1850	1500	1200	1050	900	800	700						
		600	10	M	8400	4150	2750	2050	1600	1350	1150	950	850	750	700	600	550	500	500	
				L	8700	4300	2850	2100	1650	1350	1150	1000	900	800	700	650	600	550	500	

★ The speed is applicable when axis stroke is 700 mm or less (acceleration/deceleration time: 0.36 sec).

(mm)

Drive system	Actuator	Speed (mm/s)	Lead (mm)	Slider	Load: W [kg]															
					110	120	130	140	150	160	170	180	190	200	210	220	230	240	250	
Ball screw	BE60J	900	20	M	800	700	600	600	500	500	500	400	400	400						
				L	800	800	700	600	600	500	500	400	400							
		450	10	M	900	800	700	700	600	600	500	500	400	400	400	400	400	300		
				L	900	800	800	700	600	600	600	500	500	400	400	400	400	300		

★ The speed is applicable when axis stroke is 1000 mm or less (acceleration/deceleration time: 0.27 sec).

(mm)

Drive system	Actuator	Speed (mm/s)	Lead (mm)	Slider	Load: W								
					5Kg	10Kg	15Kg	20Kg	25Kg	30Kg	35Kg	40Kg	
Timing belt	BE10E	1000	21	S	310	105	-	-	-	-	-	-	-
				M	690	340	220	-	-	-	-	-	
	BE10F	1000	21	S	310	105	-	-	-	-	-	-	
				M	690	340	220	160	-	-	-	-	
	2000	42	S	93	31	-	-	-	-	-	-		
			M	207	102	66	48	-	-	-	-		
	BE30E	1000	21	M	1180	585	400	-	-	-	-		
				L	1342	670	462	-	-	-	-		
	BE30F	1000	21	M	1135	585	400	305	225	185	155	130	
				L	1290	670	460	355	295	250	220	190	
		2000	42	M	454	454	454	454	-	-	-	-	
				L	516	268	184	142	-	-	-	-	
	BE50F	1000	21	M	5320	2620	1720	1265	995	815	685	590	
				L	5545	2730	1790	1325	1040	855	720	615	
	BE50G	2000	42	M	2128	1048	688	506	-	-	-	-	
				L	2218	1092	716	530	-	-	-	-	

★ The speed is applicable when the lead is 21 mm and acceleration/deceleration time is 0.3 sec, and when the lead is 42 mm and acceleration/deceleration time is 0.5 sec.

[Table of allowable dynamic load moment] BE10, BE30, BE50, BE60

Load type II [Mounted horizontally]
Wall-mounted

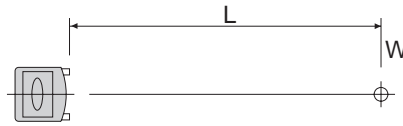

Arm length up to the center of gravity of load: L

(mm)

Drive system	Actuator	Speed (mm/s)	Lead (mm)	Slider	Load: W																
					5Kg	10Kg	15Kg	20Kg	25Kg	30Kg	35Kg	40Kg	45Kg	50Kg	55Kg	60Kg	65Kg	70Kg	75Kg	80Kg	
Ball screw	BE10E	1200	20	S	335	130	60	-	-	-	-	-	-	-	-	-	-	-	-	-	
				M	660	290	165	-	-	-	-	-	-	-	-	-	-	-	-	-	-
		600	10	S	440	165	85	40	12	-	-	-	-	-	-	-	-	-	-	-	-
				M	715	310	175	110	72	45	-	-	-	-	-	-	-	-	-	-	-
		300	5	S	467	180	90	45	17	0	-	-	-	-	-	-	-	-	-	-	-
				M	720	305	175	110	72	45	27	15	3	-	-	-	-	-	-	-	-
	BE30E	1200	20	M	1342	610	388	275	-	-	-	-	-	-	-	-	-	-	-	-	-
				L	1435	855	413	290	-	-	-	-	-	-	-	-	-	-	-	-	-
		600 (300)	10 (5)	M	1467	670	423	300	228	175	140	115	95	80	-	-	-	-	-	-	-
				L	1482	675	428	300	228	180	143	115	95	80	-	-	-	-	-	-	-
	BE30F	1200	20	M	1285	610	385	275	205	160	130	105	-	-	-	-	-	-	-	-	-
				L	1375	655	410	290	220	170	135	110	-	-	-	-	-	-	-	-	-
		600 (300)	10 (5)	M	1405	670	420	300	225	175	140	115	95	80	65	55	45	35	30	20	
				L	1420	675	425	300	230	180	140	115	95	80	65	55	45	35	30	25	
	BE50F	1200	20	M	5690	2815	1855	1375	1085	895	760	655	575	510	460	415	-	-	-	-	
				L	5900	2915	1920	1425	1125	930	785	680	595	530	475	430	-	-	-	-	
		600 (300)	10 (5)	M	6055	2995	1975	1460	1155	850	805	695	610	545	490	440	405	370	340	315	
				L	6085	3010	1985	1470	1165	955	810	700	615	545	490	445	405	370	340	315	
	BE50G	1200	20	M	5690	2815	1855	1375	1085	895	760	655	575	510	460	415	375	345	320	295	
				L	5900	2915	1920	1425	1125	930	785	680	595	530	475	430	390	360	330	305	
		600 (300)	10 (5)	M	6055	2995	1975	1460	1155	950	805	695	610	545	490	440	405	370	340	315	
				L	6085	3010	1985	1470	1165	955	810	700	615	545	490	445	405	370	340	315	

★ The speed is applicable when axis stroke is 600 mm or less (acceleration/deceleration time: 0.36 sec).
(mm)

Drive system	Actuator	Speed (mm/s)	Lead (mm)	Slider	Load: W									
					85Kg	90Kg	95Kg	100Kg	110Kg	120Kg	130Kg	140Kg	150Kg	
Ball screw	BE50F	600 (300)	10 (5)	M	290	272	255	240	-	-	-	-	-	-
				L	295	275	255	240	-	-	-	-	-	
	BE50G	1200	20	M	275	255	240	220	-	-	-	-	-	
				L	285	265	245	230	-	-	-	-	-	
	600 (300)	10 (5)	M	290	270	255	240	210	185	170	150	135		
			L	295	275	255	240	210	190	170	150	135		

★ The speed is applicable when axis stroke is 600 mm or less (acceleration/deceleration time: 0.36 sec).

Drive system	Actuator	Speed (mm/s)	Lead (mm)	Slider	Load: W [kg]														
					10	20	30	40	50	60	70	80	90	100	110	120	130	140	150
Ball screw	BE60G	1200	20	M	8365	4065	2665	1965	1515	1265	1065	915	765	665					
				L	8765	4315	2815	2065	1615	1315	1115	965	815	715					
		600	10	M	8965	4365	2865	2115	1665	1365	1115	965	815	715	665	565	515	465	415
				L	9015	4415	2865	2115	1665	1365	1115	965	865	715	665	565	515	465	415

★ The speed is applicable when axis stroke is 700 mm or less (acceleration/deceleration time: 0.36 sec).
(mm)

Drive system	Actuator	Speed (mm/s)	Lead (mm)	Slider	Load: W [kg]														
					110	120	130	140	150	160	170	180	190	200	210	220	230	240	250
Ball screw	BE60J	900	20	M	815	715	615	615	515	515	415	415	415	315					
				L	815	715	715	615	615	515	515	415	415	415					
		450	10	M	815	815	715	615	615	515	515	415	415	415	315	315	315	315	215
				L	815	815	715	615	615	515	515	415	415	415	315	315	315	315	215

★ The speed is applicable when axis stroke is 1000 mm or less (acceleration/deceleration time: 0.27 sec).
(mm)

Drive system	Actuator	Speed (mm/s)	Lead (mm)	Slider	Load: W								
					5Kg	10Kg	15Kg	20Kg	25Kg	30Kg	35Kg	40Kg	
Timing belt	BE10E	1000	21	S	335	130	60	-	-	-	-	-	-
				M	660	290	165	-	-	-	-	-	
	BE10F	1000	21	S	335	130	60	35	-	-	-	-	
				M	660	290	165	105	-	-	-	-	
	2000	42	S	100	39	-	-	-	-	-	-		
			M	198	87	-	-	-	-	-	-		
	BE30E	1000	21	M	1342	610	388	-	-	-	-	-	
				L	1435	655	413	-	-	-	-	-	
	BE30F	1000	21	M	1285	610	385	275	205	160	130	105	
				L	1375	655	410	290	220	170	135	110	
		2000	42	M	514	244	154	110	-	-	-	-	
				L	550	262	164	116	-	-	-	-	
	BE50F	1000	21	M	5690	2815	1855	1375	1085	895	760	655	
				L	5900	2915	1920	1425	1125	930	785	680	
	BE50G	2000	42	M	2276	1126	742	550	-	-	-	-	
				L	2360	1166	768	570	-	-	-	-	

★ The speed is applicable when the lead is 21 mm and acceleration/deceleration time is 0.3 sec, and when the lead is 42 mm and acceleration/deceleration time is 0.5 sec.

Actuator

[Table of allowable dynamic load moment] BE10, BE30, BE50, BE60

Load type III [Mounted horizontally]

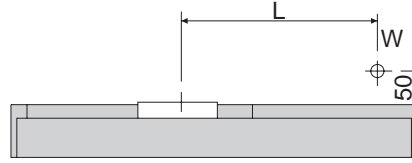

Arm length up to the center of gravity of load: L

Drive system	Actuator	Speed (mm/s)	Lead (mm)	Slider	Load: W															
					5Kg	10Kg	15Kg	20Kg	25Kg	30Kg	35Kg	40Kg	45Kg	50Kg	55Kg	60Kg	65Kg	70Kg	75Kg	80Kg
Ball screw	BE10E	1200	20	S	215	105	70	50	-	-	-	-	-	-	-	-	-	-	-	
				M	900	415	265	210	-	-	-	-	-	-	-	-	-	-	-	-
		600	10	S	215	105	80	55	47	40	-	-	-	-	-	-	-	-	-	-
				M	837	425	265	195	153	120	-	-	-	-	-	-	-	-	-	-
		300	5	S	240	120	80	65	52	40	35	30	30	25	-	-	-	-	-	-
				M	915	465	295	205	153	120	100	85	72	65	-	-	-	-	-	-
	BE30E	1200	20	M	1380	690	480	370	-	-	-	-	-	-	-	-	-	-	-	
				L	2400	1200	835	650	-	-	-	-	-	-	-	-	-	-	-	
		600 (300)	10 (5)	M	1290	690	483	375	310	265	235	200	170	150	-	-	-	-	-	
				L	2400	1205	838	650	540	465	410	350	300	260	-	-	-	-	-	
	BE30F	1200	20	M	1330	690	480	370	305	265	235	200	-	-	-	-	-	-	-	
				L	2305	1200	835	650	540	465	410	350	-	-	-	-	-	-	-	
		600 (300)	10 (5)	M	1300	690	480	375	310	265	235	200	170	150	130	115	100	90	80	
				L	2310	1205	835	650	540	465	415	350	300	260	225	200	175	155	140	
	BE50F	1200	20	M	6380	3140	2060	1520	1200	980	930	710	620	550	490	440	-	-	-	
				L	9280	4570	3000	2215	1745	1430	1205	1040	905	800	715	645	-	-	-	
		600 (300)	10 (5)	M	6380	3140	2060	1125	1200	985	830	715	625	550	495	445	400	365	335	
				L	9280	4570	3000	2215	1745	1430	1205	1040	910	805	720	645	585	535	490	
	BE50G	1200	20	M	6380	3140	2060	1520	1200	980	830	710	620	550	490	440	400	365	335	
				L	9280	4570	3000	2215	1745	1430	1205	1040	905	800	715	645	585	535	490	
		600 (300)	10 (5)	M	6380	3140	2060	1125	1200	985	830	715	625	550	495	445	400	365	335	
				L	9280	4570	3000	2215	1745	1430	1205	1040	910	805	720	645	585	535	490	

★ The speed is applicable when axis stroke is 600 mm or less (acceleration/deceleration time: 0.36 sec). (mm)

Drive system	Actuator	Speed (mm/s)	Lead (mm)	Slider	Load: W								
					85Kg	90Kg	95Kg	100Kg	110Kg	120Kg	130Kg	140Kg	150Kg
Ball screw	BE50F	600 (300)	10 (5)	M	285	265	245	230	-	-	-	-	-
				L	415	385	355	330	-	-	-	-	-
	BE50G	1200	20	M	280	260	240	225	-	-	-	-	
				L	415	385	355	330	-	-	-	-	
	600 (300)	10 (5)	M	285	265	245	230	200	175	155	135	120	
			L	415	385	355	330	290	255	225	200	175	

★ The speed is applicable when axis stroke is 600 mm or less (acceleration/deceleration time: 0.36 sec). (mm)

Drive system	Actuator	Speed (mm/s)	Lead (mm)	Slider	Load: W [kg]														
					10	20	30	40	50	60	70	80	90	100	110	120	130	140	150
Ball screw	BE60G	1200	20	M	10300	5110	3350	2500	2000	1650	1400	1200	1050	950					
				L	16800	8300	5500	4100	3250	2650	2250	1950	1750	1550					
		600	10	M	10300	5110	3350	2500	2000	1650	1400	1200	1050	950	850	750	700	650	600
				L	16800	8300	5500	4100	3250	2650	2250	1950	1750	1550	1400	1250	1150	1050	950

★ The speed is applicable when axis stroke is 700 mm or less (acceleration/deceleration time: 0.36 sec). (mm)

Drive system	Actuator	Speed (mm/s)	Lead (mm)	Slider	Load: W [kg]														
					110	120	130	140	150	160	170	180	190	200	210	220	230	240	250
Ball screw	BE60J	900	20	M	1100	1000	900	800	800	700	700	600	600	600					
				L	1800	1700	1500	1400	1300	1200	1100	1000	1000	900					
		450	10	M	1100	1000	900	800	800	700	700	600	600	600	500	500	500	400	400
				L	1800	1700	1500	1400	1300	1200	1100	1000	1000	900	900	800	800	700	700

★ The speed is applicable when axis stroke is 1000 mm or less (acceleration/deceleration time: 0.27 sec). (mm)

Drive system	Actuator	Speed (mm/s)	Lead (mm)	Slider	Load: W							
					5Kg	10Kg	15Kg	20Kg	25Kg	30Kg	35Kg	40Kg
Timing belt	BE10E	1000	21	S	215	105	70	-	-	-	-	-
				M	900	415	265	-	-	-	-	-
	BE10F	1000	21	S	215	105	70	50	-	-	-	-
				M	900	415	265	210	-	-	-	-
		2000	42	S	64	31	-	-	-	-	-	-
				M	270	124	-	-	-	-	-	-
	BE30E	1000	21	M	1380	690	480	-	-	-	-	-
				L	2400	1200	835	-	-	-	-	-
	BE30F	1000	21	M	1330	690	480	370	305	265	235	200
				L	2305	1200	835	650	540	465	410	350
		2000	42	M	532	276	192	148	-	-	-	-
				L	922	480	334	260	-	-	-	-
	BE50F	1000	21	M	6380	3140	2060	1520	1200	980	830	710
				L	9280	4570	3000	2215	1745	1430	1205	1040
	BE50G	2000	42	M	2552	1256	824	608	-	-	-	-
				L	3712	1828	1200	886	-	-	-	-

★ The speed is applicable when the lead is 21 mm and acceleration/deceleration time is 0.3 sec, and when the lead is 42 mm and acceleration/deceleration time is 0.5 sec.

[Table of allowable dynamic load moment] BE10, BE30, BE50, BE60

Load type IV [Mounted vertically]

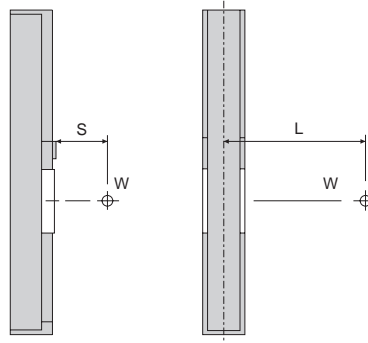

When S = 50mm:

Arm length up to the center of gravity of load: L

(mm)

Drive system	Actuator	Speed (mm/s)	Lead (mm)	Slider	Load: W																				
					3Kg	5Kg	8Kg	10Kg	12Kg	14Kg	16Kg	18Kg	20Kg	22Kg	25Kg	30Kg	35Kg	40Kg	45Kg	50Kg	55Kg	60Kg			
Ball screw	BE10E	1200	20	S	245	110	-	-	-	-	-	-	-	-	-	-	-	-	-	-	-	-			
				M	1270	730	-	-	-	-	-	-	-	-	-	-	-	-	-	-	-	-	-	-	
		600	10	S	255	115	45	20	5	-	-	-	-	-	-	-	-	-	-	-	-	-	-	-	
				M	1375	785	460	350	275	-	-	-	-	-	-	-	-	-	-	-	-	-	-	-	-
		300	5	S	290	150	75	45	20	5	-	-	-	-	-	-	-	-	-	-	-	-	-	-	
				M	1390	795	460	350	275	230	190	160	135	115	-	-	-	-	-	-	-	-	-	-	-
	BE30E	1200	20	M	1695	985	-	-	-	-	-	-	-	-	-	-	-	-	-	-	-	-	-	-	
				L	3000	1770	-	-	-	-	-	-	-	-	-	-	-	-	-	-	-	-	-	-	-
		600	10	M	1815	1060	635	490	395	-	-	-	-	-	-	-	-	-	-	-	-	-	-	-	
				L	3210	1895	1155	910	745	-	-	-	-	-	-	-	-	-	-	-	-	-	-	-	-
		300	5	M	1835	1070	640	495	400	330	280	240	210	185	-	-	-	-	-	-	-	-	-	-	-
				L	3240	1920	1165	920	755	635	545	475	420	375	-	-	-	-	-	-	-	-	-	-	-
	BE30F	1200	20	M	1915	1030	585	455	-	-	-	-	-	-	-	-	-	-	-	-	-	-	-	-	
				L	3383	1845	1075	845	-	-	-	-	-	-	-	-	-	-	-	-	-	-	-	-	-
		600	10	M	2078	1118	640	495	400	330	280	240	205	-	-	-	-	-	-	-	-	-	-	-	
				L	3655	1995	1165	920	755	625	540	470	415	-	-	-	-	-	-	-	-	-	-	-	-
		300	5	M	2073	1118	640	495	400	330	280	240	210	185	145	100	72	60	-	-	-	-	-	-	
				L	3655	1995	1165	920	755	635	545	475	420	375	305	235	193	170	-	-	-	-	-	-	-
	BE50F	1200	20	M	9848	5450	3255	2595	2155	-	-	-	-	-	-	-	-	-	-	-	-	-	-	-	
				L	14343	8037	4750	3795	3155	-	-	-	-	-	-	-	-	-	-	-	-	-	-	-	-
		600	10	M	10528	5830	3480	2775	2305	1970	1720	1520	1365	1240	1085	-	-	-	-	-	-	-	-	-	
				L	15330	8497	5080	4055	3375	2885	2520	2235	2005	1820	1595	-	-	-	-	-	-	-	-	-	-
		300	5	M	10625	5885	3515	2800	2325	1990	1735	1535	1380	1250	1095	905	770	670	590	525	-	-	-	-	
				L	10838	3942	5130	4095	3405	2910	2545	2255	2025	1840	1610	1335	1140	990	875	785	-	-	-	-	
BE50G	1200	20	M	9848	5450	3255	2595	2155	1840	1605	1420	1275	1155	1010	-	-	-	-	-	-	-	-	-		
			L	14343	8037	4750	3795	3155	2695	2355	2090	1875	1700	1490	-	-	-	-	-	-	-	-	-	-	
	600	10	M	10528	5830	3480	2775	2305	1970	1720	1520	1365	1240	1085	895	762	660	582	520	-	-	-	-		
			L	15330	8497	5080	4055	3375	2885	2520	2235	2005	1820	1595	1325	1127	980	870	775	-	-	-	-		
	300	5	M	10625	5885	3515	2800	2325	1990	1735	1535	1380	1250	1095	905	770	670	590	525	475	430	-	-		
			L	10838	3942	5130	4095	3405	2910	2545	2255	2025	1840	1610	1335	1140	990	875	785	710	645	-	-		

★ The speed is applicable when axis stroke is 600 mm or less (acceleration/deceleration time: 0.36 sec).

Actuator

(mm)

Drive system	Actuator	Speed (mm/s)	Lead (mm)	Slider	Load: W [kg]				
					10	20	30	40	50
Ball screw	BE60G	1200	20	M	9300	4550	3000		
				L	15200	7500	4950		
		600	10	M	10100	5000	3250	2400	1900
				L	16550	8200	5400	4000	3200

★ The speed is applicable when axis stroke is 700 mm or less (acceleration/deceleration time: 0.36 sec).

(mm)

Drive system	Actuator	Speed (mm/s)	Lead (mm)	Slider	Load: W [kg]										
					10	20	30	40	50	60	70	80	90	100	
Ball screw	BE60J	900	20	M	12600	6200	4100	3000	2400						
				L	20700	10200	6800	5000	4000						
		450	10	M	13400	6600	4300	3200	2500	2100	1800	1500	130	1200	
				L	21800	10800	7200	5300	4200	3500	3000	2600	2300	2000	

★ The speed is applicable when axis stroke is 1000 mm or less (acceleration/deceleration time: 0.27 sec).

When S = 200mm:

Arm length up to the center of gravity of load: L

(mm)

Drive system	Actuator	Speed (mm/s)	Lead (mm)	Slider	Load: W																		
					3Kg	5Kg	8Kg	10Kg	12Kg	14Kg	16Kg	18Kg	20Kg	22Kg	25Kg	30Kg	35Kg	40Kg	45Kg	50Kg	55Kg	60Kg	
Ball screw	BE10E	1200	20	S	95	-	-	-	-	-	-	-	-	-	-	-	-	-	-	-	-	-	
				M	1120	575	-	-	-	-	-	-	-	-	-	-	-	-	-	-	-	-	-
		600	10	S	170	0	-	-	-	-	-	-	-	-	-	-	-	-	-	-	-	-	-
				M	1255	640	300	205	130	-	-	-	-	-	-	-	-	-	-	-	-	-	-
		300	5	S	240	75	-	-	-	-	-	-	-	-	-	-	-	-	-	-	-	-	-
				M	1270	650	300	210	135	80	40	10	-	-	-	-	-	-	-	-	-	-	-
	BE30E	1200	20	M	1565	855	-	-	-	-	-	-	-	-	-	-	-	-	-	-	-	-	-
				L	2870	1640	-	-	-	-	-	-	-	-	-	-	-	-	-	-	-	-	-
		600	10	M	1685	930	505	360	265	-	-	-	-	-	-	-	-	-	-	-	-	-	-
				L	3080	1765	1025	780	615	-	-	-	-	-	-	-	-	-	-	-	-	-	-
		300	5	M	1705	940	510	365	270	185	140	100	70	45	-	-	-	-	-	-	-	-	-
				L	3110	1789	1035	790	620	505	415	345	290	230	-	-	-	-	-	-	-	-	-
	BE30F	1200	20	M	1785	900	455	325	-	-	-	-	-	-	-	-	-	-	-	-	-	-	-
				L	3253	1715	945	715	-	-	-	-	-	-	-	-	-	-	-	-	-	-	-
		600	10	M	1925	977	505	360	265	185	135	95	65	-	-	-	-	-	-	-	-	-	-
				L	3488	1845	1025	780	615	495	410	340	285	-	-	-	-	-	-	-	-	-	-
		300	5	M	1913	987	510	365	265	185	140	100	70	45	7	-	-	-	-	-	-	-	-
				L	3525	1865	1035	790	620	505	415	35	290	230	175	110	67	30	-	-	-	-	-
	BE50F	1200	20	M	9783	5387	3190	2535	2090	-	-	-	-	-	-	-	-	-	-	-	-	-	-
				L	14280	7885	4690	3730	3090	-	-	-	-	-	-	-	-	-	-	-	-	-	-
		600	10	M	10463	5765	3415	2710	2240	1905	1655	1460	1300	1175	1020	-	-	-	-	-	-	-	
				L	15220	8432	5015	3990	3310	2820	2455	2170	1940	1755	1535	-	-	-	-	-	-	-	
		300	5	M	10560	5820	3450	2735	2265	1925	1670	1475	1315	1185	1030	840	707	605	527	465	-	-	
				L	15408	8512	5065	4030	3340	2850	2480	2190	1960	1775	1550	1270	1078	930	815	720	-	-	
BE50G	1200	20	M	9783	5387	3190	2535	2090	1775	1540	1360	1210	1090	950	-	-	-	-	-	-	-		
			L	14280	7885	4690	3730	3090	2635	2290	2025	1810	1635	1425	-	-	-	-	-	-	-		
	600	10	M	10463	5765	3415	2710	2240	1905	1655	1460	1300	1175	1020	835	700	600	522	460	-	-		
			L	6085	8432	5015	3990	3310	2820	2455	2170	1940	1755	1535	1260	1065	920	805	715	-	-		
	300	5	M	10560	5820	3450	2735	2265	1925	1670	1475	1315	1185	1030	840	707	605	527	465	415	370		
			L	15408	8512	5065	4030	3340	2850	2480	2190	1960	1775	1550	1270	1078	930	815	720	645	585		

★ The speed is applicable when axis stroke is 600 mm or less (acceleration/deceleration time: 0.36 sec).

Drive system	Actuator	Speed (mm/s)	Lead (mm)	Slider	Load: W [kg]									
					10	20	30	40	50	60	70	80	90	100
Ball screw	BE60G	1200	20	M	9150	4400	2850	-	-	-	-	-	-	-
				L	15050	7350	4800	-	-	-	-	-	-	
		600	10	M	9950	4850	3100	2250	1750	-	-	-	-	
				L	16400	8050	5250	3850	3050	-	-	-	-	
Ball screw	BE60J	900	20	M	12500	6100	3900	2900	2200	-	-	-	-	
				L	20500	10100	6600	4900	3800	-	-	-	-	
		450	10	M	13200	6400	4200	3100	2400	1900	1600	1400	1200	1000
				L	21700	10700	7000	5200	4100	3300	2800	2400	2100	1900

★ BB60G: The speed is applicable when axis stroke is 700 mm or less (acceleration/deceleration time: 0.36 sec).

BB60J: The speed is applicable when axis stroke is 1000 mm or less (acceleration/deceleration time: 0.27 sec).

[Table of allowable dynamic load moment] BE10, BE30, BE50, BE60

Load type V [Mounted vertically]

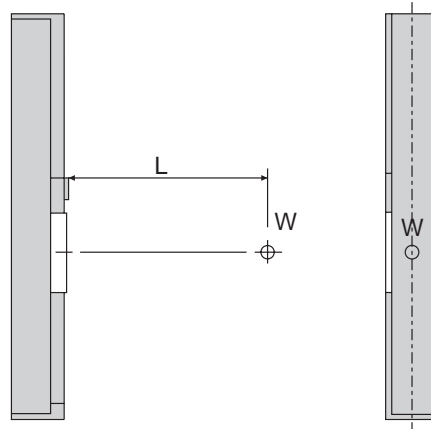

Arm length up to the center of gravity of load: L

(mm)

Drive system	Actuator	Speed (mm/s)	Lead (mm)	Slider	Load: W																		
					3Kg	5Kg	8Kg	10Kg	12Kg	14Kg	16Kg	18Kg	20Kg	22Kg	25Kg	30Kg	35Kg	40Kg	45Kg	50Kg	55Kg	60Kg	
Ball screw	BE10E	1200	20	S	295	160	-	-	-	-	-	-	-	-	-	-	-	-	-	-	-	-	
				M	1325	780	-	-	-	-	-	-	-	-	-	-	-	-	-	-	-	-	-
		600	10	S	355	190	95	70	50	-	-	-	-	-	-	-	-	-	-	-	-	-	-
				M	1405	830	510	510	400	330	-	-	-	-	-	-	-	-	-	-	-	-	-
		300	5	S	390	210	110	75	50	40	30	25	20	15	-	-	-	-	-	-	-	-	-
				M	1420	835	510	400	330	280	240	210	185	165	-	-	-	-	-	-	-	-	-
	BE30E	1200	20	M	1925	1140	-	-	-	-	-	-	-	-	-	-	-	-	-	-	-	-	
				L	3370	2005	-	-	-	-	-	-	-	-	-	-	-	-	-	-	-	-	
		600	10	M	2060	1220	750	590	485	-	-	-	-	-	-	-	-	-	-	-	-	-	
				L	3605	2150	1330	1055	870	-	-	-	-	-	-	-	-	-	-	-	-	-	
		300	5	M	2080	1235	755	595	490	415	360	315	280	250	-	-	-	-	-	-	-	-	
				L	3640	2170	1340	1070	880	750	650	575	515	465	-	-	-	-	-	-	-	-	
	BE30F	1200	20	M	2173	1190	700	550	-	-	-	-	-	-	-	-	-	-	-	-	-		
				L	3798	2092	1240	985	-	-	-	-	-	-	-	-	-	-	-	-	-		
		600	10	M	2323	1272	750	590	485	410	355	310	275	-	-	-	-	-	-	-	-		
				L	4198	2375	1330	1055	870	740	645	570	510	-	-	-	-	-	-	-	-		
		300	5	M	2345	1285	755	595	490	415	360	315	280	250	215	175	145	120	-	-	-		
				L	4100	2260	1340	1070	880	750	650	575	515	465	402	330	277	235	-	-	-		
	BE50F	1200	20	M	11173	6197	3700	2950	2450	-	-	-	-	-	-	-	-	-	-	-			
				L	16300	9035	5400	4310	3585	-	-	-	-	-	-	-	-	-	-	-			
		600	10	M	11963	6625	3955	3155	2620	2240	1955	1730	1555	1410	1235	-	-	-	-				
				L	17423	9657	5775	4610	3835	3280	2865	2540	2280	2070	1815	-	-	-	-				
		300	5	M	12075	6732	9559	3185	2645	2260	1975	1750	1570	1420	1245	1030	877	760	670	600			
				L	17588	9750	5830	4655	3870	3310	2890	2565	2305	2090	1835	1520	1297	1130	997	895			
BE50G	1200	20	M	11193	6197	3700	2950	2450	2095	1825	1620	1450	1315	1150	-	-	-	-					
			L	16300	9035	5400	4310	3585	3065	2675	2375	2130	1935	1695	-	-	-	-					
	600	10	M	11963	6625	3955	3155	2620	2240	1955	1730	1555	1410	1235	1020	867	755	665					
			L	17423	9657	5775	4610	3835	3280	2865	2540	2280	2070	1815	1505	1285	1115	987					
	300	5	M	12075	6735	3995	3185	2645	2260	1975	1750	1570	1420	1245	1030	877	760	670					
			L	17588	9750	5830	4655	3870	3310	2890	2565	2305	2090	1835	1520	1297	1130	997					

★ The speed is applicable when axis stroke is 600 mm or less (acceleration/deceleration time: 0.36 sec).

Actuator

(mm)

Drive system	Actuator	Speed (mm/s)	Lead (mm)	Slider	Load: W [kg]									
					10	20	30	40	50	60	70	80	90	100
Ball screw	BE60G	1200	20	M	9315	4615	3015	-	-	-	-	-	-	-
				L	15265	7565	5015	-	-	-	-	-	-	
		600	10	M	10165	5015	3315	2465	1965	-	-	-	-	
				L	16615	8265	5465	4065	3215	-	-	-	-	
Ball screw	BE60J	900	20	M	12715	6315	4115	3115	2415	-	-	-		
				L	20715	10315	6815	5115	4015	-	-	-		
		450	10	M	13415	6615	4415	3215	2615	2115	1815	1515	1415	
				L	21915	10915	7215	5415	4315	3515	3015	2615	2315	

★ BB60G: The speed is applicable when axis stroke is 700 mm or less (acceleration/deceleration time: 0.36 sec).
 BB60J: The speed is applicable when axis stroke is 1000 mm or less (acceleration/deceleration time: 0.27 sec).

Operation Mode

[Sequential mode]

Mode in which a program created, using instruction words, is executed in the order of steps.

Type of master unit		CA25-M10, CA25-M40, CA25-M80
No. of program steps		2,000 steps
Coordinate table		999 points
Speed setting		10 steps (variable)
Acceleration/deceleration setting		20 steps (variable)
Number of counters		99
Number of timers		9
Multitask	Maximum number of tasks	4 tasks (Axis control possible by all tasks)
	Maximum number of controlled axes	4 axes
	Maximum number of controlled axes per task	4 axes

Example programming in sequential mode

[Motion]
When general-purpose input port 1-3 is ON after the axes reach point B via point A from the origin, they move to point C (good product). When it is OFF, they move to point D (rejected product).

	X	Y
Coordinates of point A	(100,	0)
Coordinates of point B	(200,	200)
Coordinates of point C	(200,	300)
Coordinates of point D	(300,	200)

[Example of using general-purpose input signals]
Signal for good product: Port 1-3 ON
Signal for rejected product: Port 1-3 OFF
For input signal timing: Use of port 1-8

Flow chart	Example program			
	Step	Command	Data	Comment
	0001	SPD	V = 05	
	0002	MOV	a S V = 00 X = 100 POST Y = 0	Point (A)
	0003	MOV	a S V = 00 X = 200 POST Y = 200	Point (B)
	0004	IN	PORT [1] 1	Waiting for input of good or rejected product judgment signal.
	0005	JMPI	10 PORT [1] 1 . .	When general-purpose input port 1-3 is ON, jump to tag No.10.
	0006	MOV	a S V = 00 X = 300 POST Y = 200	Point (D) (when rejected product judgment signal has reached)
	0007	END		
	0008	TAG	10	
	0009	MOV	a S V = 00 X = 200 POST Y = 300	Point (C) (when good product judgment signal has reached)
	0010	END		

[Input timing of general-purpose input signals]
After the good product or rejected product judgment signal (general-purpose input port 1-3) is ON, the timing signal (general-purpose input port 1-8) is input.

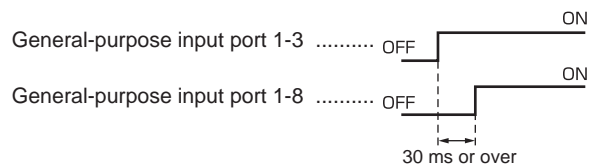

List of commands (instruction words) for sequential mode

Controller: CA25-M10, CA25-M40, CA25-M80
Teach pendant: TPH-4C

Command	Description
Command for axis movement	
MOV	Axis travel
MOVP	Axis travel (coordinate table indirect)
MVC	Circular interpolation
MVCP	Circular interpolation (coordinate table indirect)
MVB	Move to just preceding position (return to just preceding position).
MVE	Escape movement
RSMV	Axis travel via RS232C.
HOME	Home return command
Command for parameter setting	
SPD	Speed setting
ACC	Acceleration/deceleration setting
OFS	Offset setting
OFSP	Offset setting (Specified by coordinate table.)
PASS	Setting the pass rate.
Command for I/O port control	
OUT	Output to general-purpose port.
OUTP	Pulse output to general-purpose port.
OUTC	Counter value output to general-purpose port.
OUTS	Specified coordinate output to general-purpose port.
IOUT	Output to internal port.
CANS	Cancel of specified coordinate output to general-purpose port.
IN	Waiting for input.
INPC	Setting of input status of general-purpose port to counter.
INSP	Waiting for internal port input.
Command for timer/counter control	
CWIT	Waiting for counter.
TIM	Waiting for time.
TIMP	Preset of timer.
CNT	Preset of counter.
CNT +	Addition of counter value.
CNT -	Subtraction of counter value.
CNTC	Clear of all counters.

Command	Description
Command for program control	
NOP	Non-operation
RET	Return (declaration of ending a subroutine).
STOP	Stop
END	Program end
TAG	Jump to a tag (destination label)
PSEL	Program selection
Command for servo control	
SVON	Servo ON
SVOF	Servo OFF
Command for matrix operation	
MVM	Matrix movement
LOOP	MVM loop
MINI	Initialization of MVM counter.
Command for jump	
JMP	Unconditional jump.
JMPI	Jump with input condition.
JMPC	Jump with counter condition.
JMPT	Jump with timer condition.
BRAC	Jump to a tag of counter value.
Command for subroutine call	
CAL	Unconditional call
CALI	Call with input condition
CALC	Call with counter condition.
CALT	Call with timer condition.
Command for task control	
TSTR	Task start
TSTO	Temporary stop of task.
TRSA	Task restart
TCAN	Compulsive finish of task.

[External point designation mode]

Mode in which an axis is positioned by a signal output from the sequencer (PLC) or digital switch, without using a command of the controller. Coordinates of a specified point, speed and acceleration/deceleration should be registered beforehand in the table of the controller.

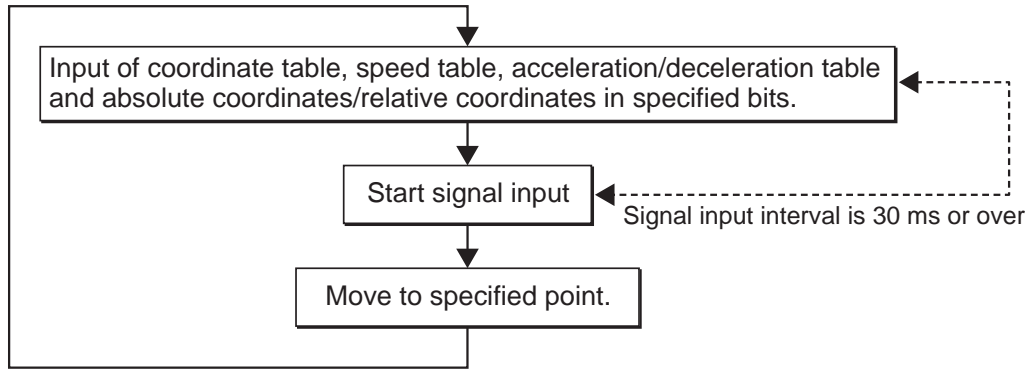

No. of tables that can be used:

Type of master unit: CA25-M10, CA25-M40, CA25-M80

	Without extension I/O unit	With extension I/O unit	With CC-Link/DeviceNet unit
Coordinate table	Max. 256 points (max. 8 bits) (*1)	999 points (10 bits)	
Speed table	1 table (Fixed at table no. 1)	10 tables (4 bits)	
Acceleration/ deceleration table	1 table (Fixed at table no. 5)	20 tables (5 bits)	
Coordinate system	Predetermined to absolute coordinate system (Bit designation is not permitted.)	Absolute coordinate system/relative coordinate system (1 bit)	

(*1) When using two or more axes, one axis has 16 points (4 bits).

[Palletizing mode]

Mode in which operations of traveling and loading to pallets can be programmed easily only by specifying the number of workpieces, coordinates of locations, etc., without creating a program by combining instruction words.

A total of three patterns is provided.

M to 1

Move from pallet to a specified point.

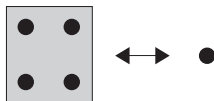

1 to M

Move from a specified point to pallet.

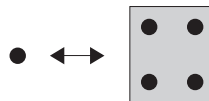

M to M



Move from pallet to pallet.



Master unit: CA25-M10, CA25-M40, CA25-M80

[Details of system input and output] *For the table of I/O pin numbers, see page 169.

[System input]

Pin no.	Setting function	◇ Sequential mode ◇ Palletizing mode	◇ External point designation mode	Remarks
	Signal name			
28	Home return	ON: Start of home return operation	Same as left	Detecting of rising edge 
29	Start	ON: Start from currently stopped step or from paused state	ON: Start movement based on currently specified table information	Detecting of rising edge 
30	Stop	ON: Stop after execution of current step is completed.	Disabled	Home return when this input is ON. Start input is disabled.
31	Reset	ON: Reset of error state (Enabled while program execution is stopped)	ON: Reset of error state	

[System Output]

Pin no.	Setting function	◇ Sequential mode ◇ Palletizing mode	◇ External point designation mode	Remarks
	Signal name			
11	Running	ON during program execution and during home return operation	ON during robot operation and home return operation	
12	Error	ON when error occurs	Same as left	
13	Positioning complete	ON when robot positioning is complete OFF while robot is moving (OFF while robot is paused)	Same as left	
14	Home return complete	ON when home return is unnecessary due to execution of movement command OFF when home return is necessary	Same as left	

[Input and Output Assignable to General-purpose I/O Ports]

Signal name	*Setting function	◇ Sequential mode ◇ Palletizing mode	◇ External point designation mode
	Input/output		
Robot single operation	Input	Single operation mode is activated when this input is ON while the start input or start key is set to ON. In this mode, the program stops after executing an axis movement command or output command.	Disabled
Resume	Input	When this input is set to ON, the content of the counter and other devices is not cleared even if the power is turned off or reset.	Disabled
Escape	Input	When this input is set to ON during execution of an MVE command, the axis slows down and stops, and the system assumes that the current step has finished.	Disabled
Pause	Input	ON: Pause (Slowdown stop) To restart, set the start input to ON. To cancel, set the reset input to ON.	
Program selection 2 ⁰ Program selection 2 ¹ Program selection 2 ² Program selection 2 ³	Input	This is the input signal for specifying the program number (no. 1 to no. 16) at program selection.	Disabled
Palletizing	Input	ON: Palletizing mode OFF: Sequential mode This input is disabled when external point designation mode is set.	Disabled
Wait for input	Output	ON when the system is waiting for an input during program execution	Disabled
Pausing	Output	This is ON after pause input is recognized, and the axis slows down and stops. (This is OFF when pause mode is canceled.)	
READY	Output	This is ON when the teach pendant and RS-232C are disabled, but no error has occurred.	
Servo ON	Input	ON: Servo can be locked. OFF: Servo cannot be locked.	
Battery alarm	Output	This is ON when the backup voltage is low in one of the controllers in the configuration, and this is OFF when the backup voltages for all controllers in the configuration are recovered. This is disabled when the encoder type is set to incremental.	
Positioning complete by task	Output	This is ON when positioning is complete for every task.	
Home return complete by task	Output	This is ON when home return is complete for every task.	
Torque limit 2 ⁰ Torque limit 2 ¹ Torque limit 2 ²	Input	This input signal specifies the torque limit table (8 tables) when using the maximum torque limit function.	

Master Units CA25-M10, CA25-M40, CA25-M80

[Input/Output Connection Example]

NPN Input/Output

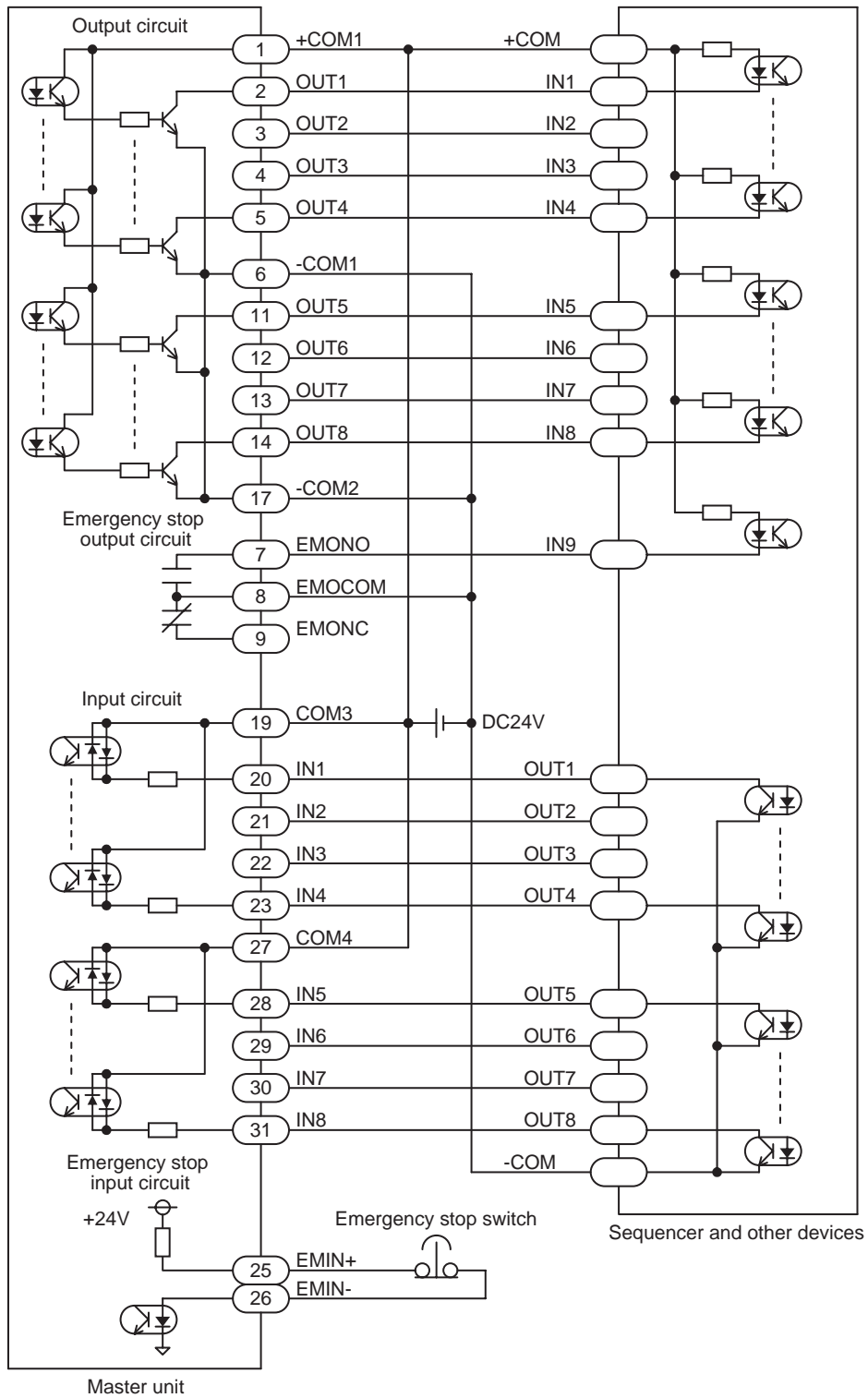

Notes

- -COM1 and -COM2 are connected internally.
- COM3 and COM4 are not connected internally.

Master Units CA25-M10, CA25-M40, CA25-M80

[Input/Output Connection Example]

PNP Input/Output

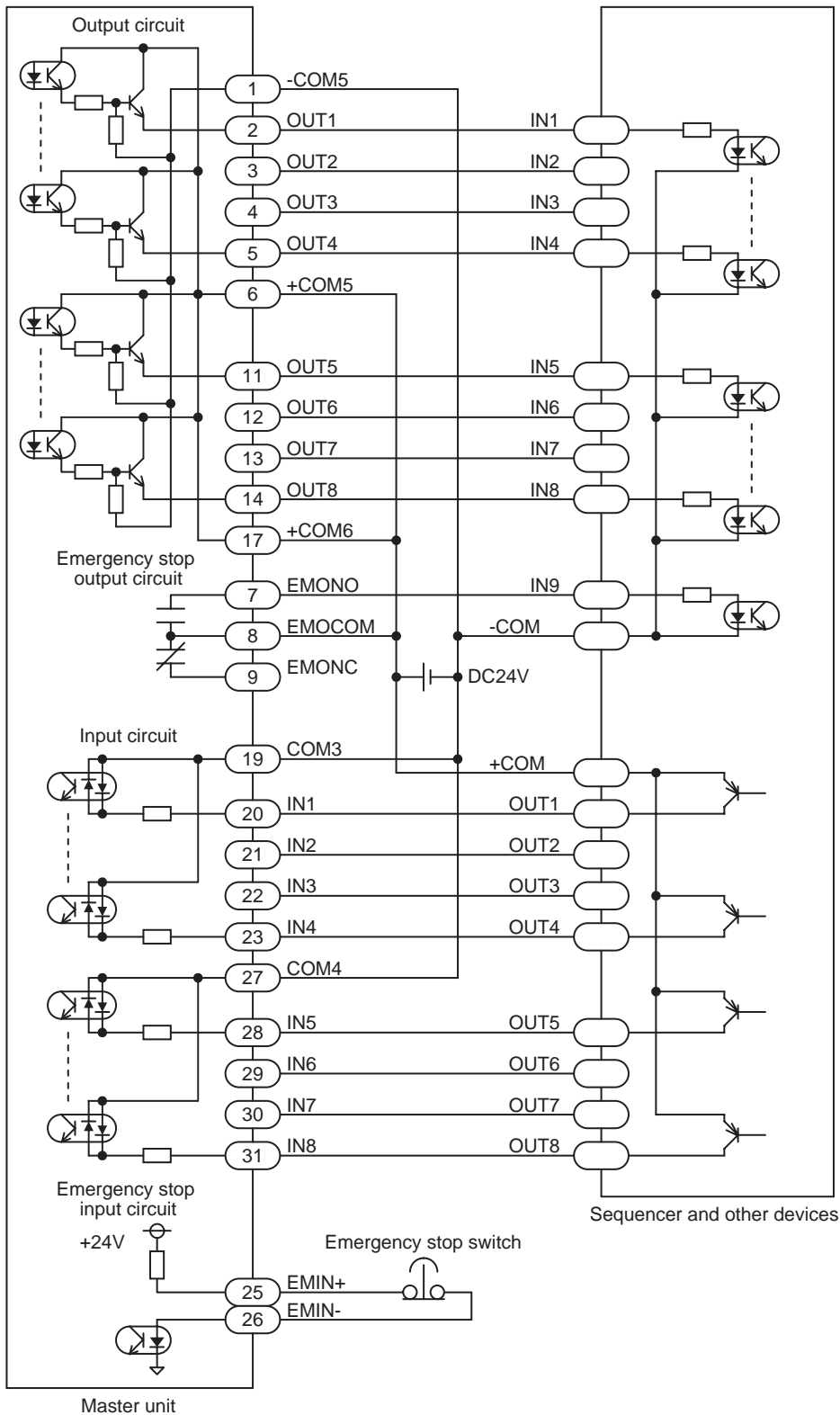

- Notes**
- +COM5 and +COM6 are connected internally.
 - COM3 and COM4 are not connected internally.

Master Units CA25-M10, CA25-M40, CA25-M80

[Extension Input/Output Unit Connection Example]

NPN Input/Output

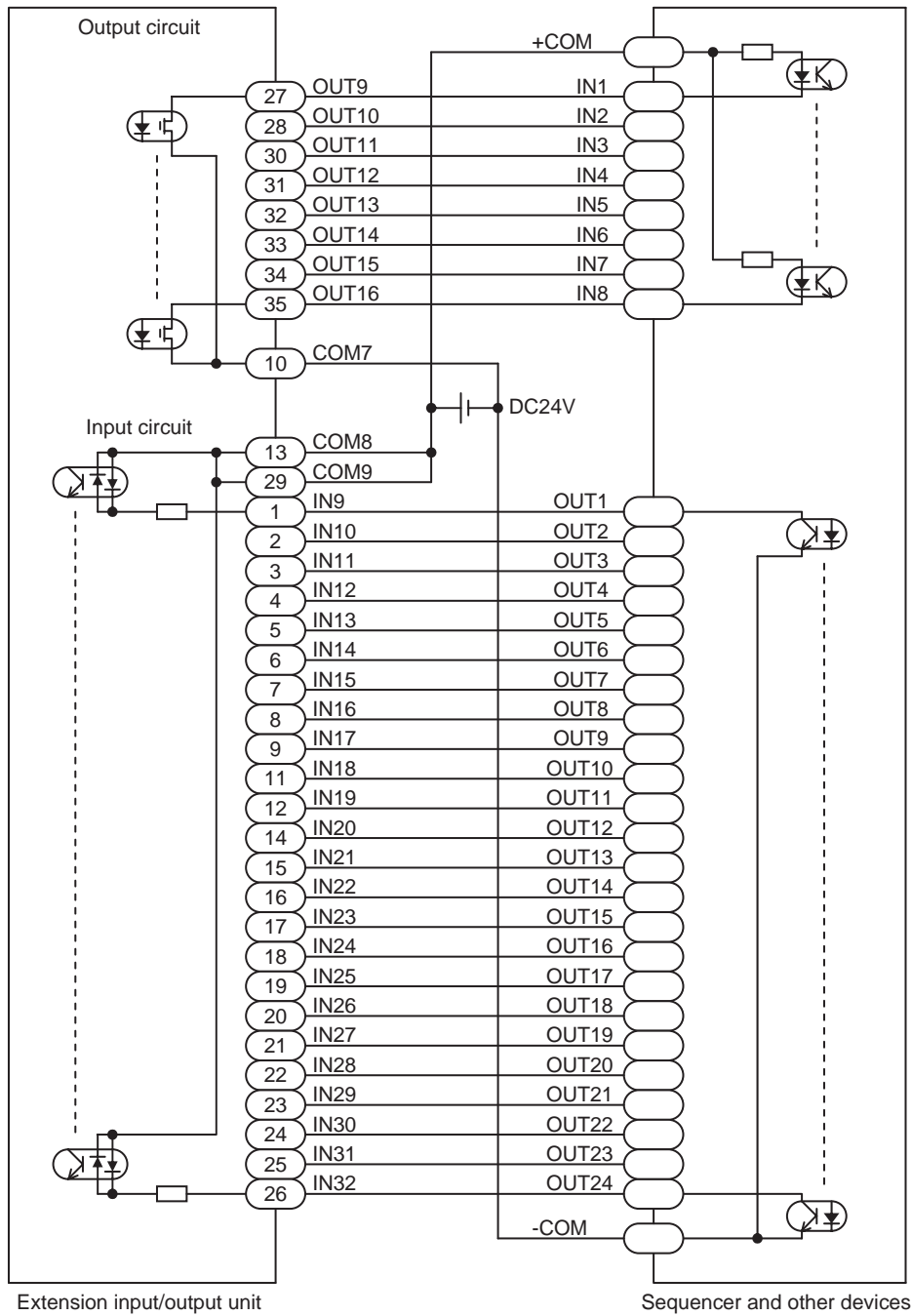

Notes

- COM7 is not connected to COM8 or COM9.
- COM8 and COM9 are connected internally.

Master Units CA25-M10, CA25-M40, CA25-M80

[Extension Input/Output Unit Connection Example]

PNP Input/Output

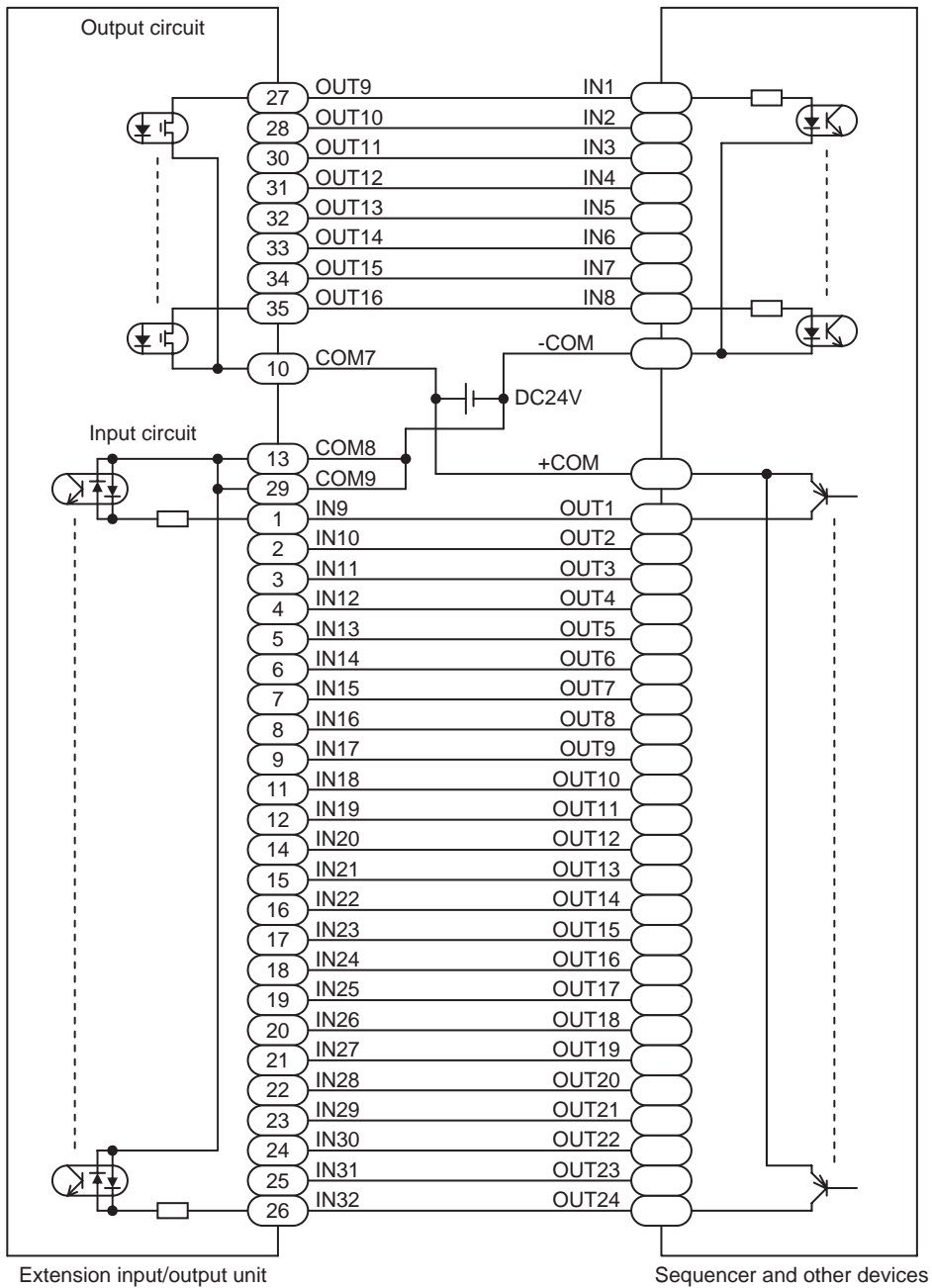

Notes

- COM7 is not connected to COM8 or COM9.
- COM8 and COM9 are connected internally.

Master Units CA25-M10, CA25-M40, CA25-M80

[Dedicated CC-Link Cable Connection]

The cables can be connected to the station numbers in any order.

Be sure to connect terminating resistors to both ends of the CC-Link system.

Connect each terminating resistor between DA and DB.

The terminating resistors to be connected vary depending on the cables that are used in the CC-Link system.

Cable type	Terminating resistor
Dedicated CC-Link cable	110 Ω 1/2W (brown, brown, brown)
Ver. 1.10 compliant dedicated CC-Link cable	
Dedicated CC-Link high-performance cable	130 Ω 1/2W (brown, orange, brown)

The terminating resistors are not supplied with this controller.

The master unit can also be connected at locations other than both ends.

A star configuration is not allowed.

The connection method is shown in the figure below.

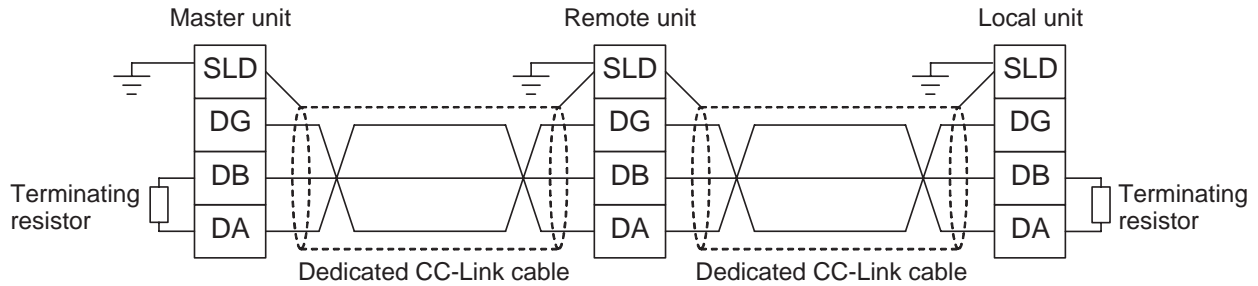

For details on the cable connections, see the operation manual for the master station and the CC-Link installation manual (published by the CC-Link Partner Association).

* If communication problems occur due to noise, check the ground installation of the controller.

* The dedicated CC-Link cable must be obtained by the customer.

[System Input/Output]

(1) System Input (CC-Link Master Station --> CA25-M10-*CC)

Signal name	Remote output	Normal mode	External point designation mode	Remarks
Home return	RYn0	ON: Home return operation start	Home return	Rising edge detection
Start	RYn1	ON: Restart from currently stopped step or from paused state	ON: Start movement based on currently specified table information	
Stop	RYn2	ON: Stop after execution of current step is completed.	Disabled	Home return when this input is ON. Start input is disabled.
Reset	RYn3	ON: Reset of error state (Enabled while program execution is stopped)	ON: Reset of error state	
Jog input	RY(n+4)8 to RY(n+4)F	Three types of operation modes (inching, low-speed movement, and high-speed movement) and the movement direction are specified, and jog movement is performed for the selected axis.		

(2) System Output (CA25-M10-*CC --> CC-Link Master Station)

Signal name	Remote input	Normal mode	External point designation mode
Running	RXn0	ON during controller execution and during home return operation	ON during robot operation
Error	RXn1	ON when error occurs	Same as left
Positioning complete	RXn2	ON when robot positioning is complete OFF while robot is moving (OFF while robot is paused)	Same as left
Home return complete	RXn3	ON when home return is complete	Same as left
Jog output	RX(n+4)8 to RX(n+4)F	This indicates a status where a jog command cannot be received, operation is in progress, or similar condition.	

Master Units CA25-M10, CA25-M40, CA25-M80

[Dedicated DeviceNet Cable Connection]

The cables can be connected in any order regardless of the station number setting (MAC ID).

Be sure to connect terminating resistors to both ends of the trunk line. (121Ω, 1% metal coating, 1/4 W)

Connect the terminating resistor between CANH and CANL.

This controller does not include a terminating resistor.

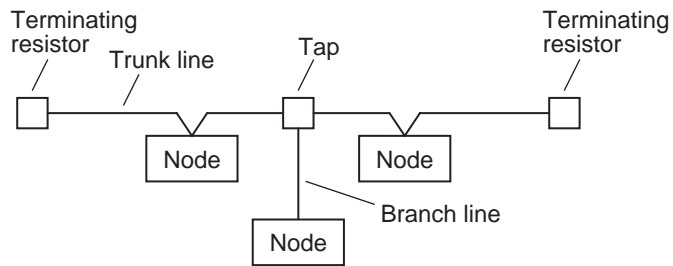

For details on the cable connections, see the master station operation manual or the documentation published by ODVA.

[System Input/Output]

(1) System Input (DeviceNet Master Station --> CA25-M10-*DC)

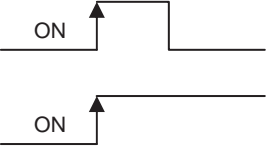
Signal name	Output device (*1)	Normal mode	External point designation mode	Remarks
Home return	+0	ON: Home return operation start	Home return	Rising edge detection
Start input	+1	ON: Restart from currently stopped step or from paused state	ON: Start movement based on currently specified table information	
Stop input	+2	ON: Stop after execution of current step is completed.	Disabled	Home return when this input is ON. Start input is disabled.
Reset input	+3	ON: Reset of error state (Enabled while program execution is stopped)	ON: Reset of error stat	
Jog input	+72 to +79	Three types of operation modes (inching, low-speed movement, and high-speed movement) and the movement direction are specified, and jog movement is performed for the selected axis.		

*1) Offset amount from starting device (unit: bits)

(2) System Output (CA25-M10-*DC --> DeviceNet Master Station)

Signal name	Input device (*1)	Normal mode	External point designation mode
Output during operation	+0	ON during controller execution and during home return operation	ON during robot operation
Error output	+1	ON when error occurs	Same as left
Positioning complete output	+2	ON when robot positioning is complete OFF while robot is moving (OFF while robot is paused)	Same as left
Home return complete output	+3	ON when home return is complete	Same as left
Jog output	+72 to +79	This indicates a status where a jog command cannot be received, operation is in progress, or similar condition.	

*1) Offset amount from starting device (unit: bits)

Slave Units CA25-S10, CA25-S40, CA25-S80

[Input/Output Connection Example]

NPN Input/Output

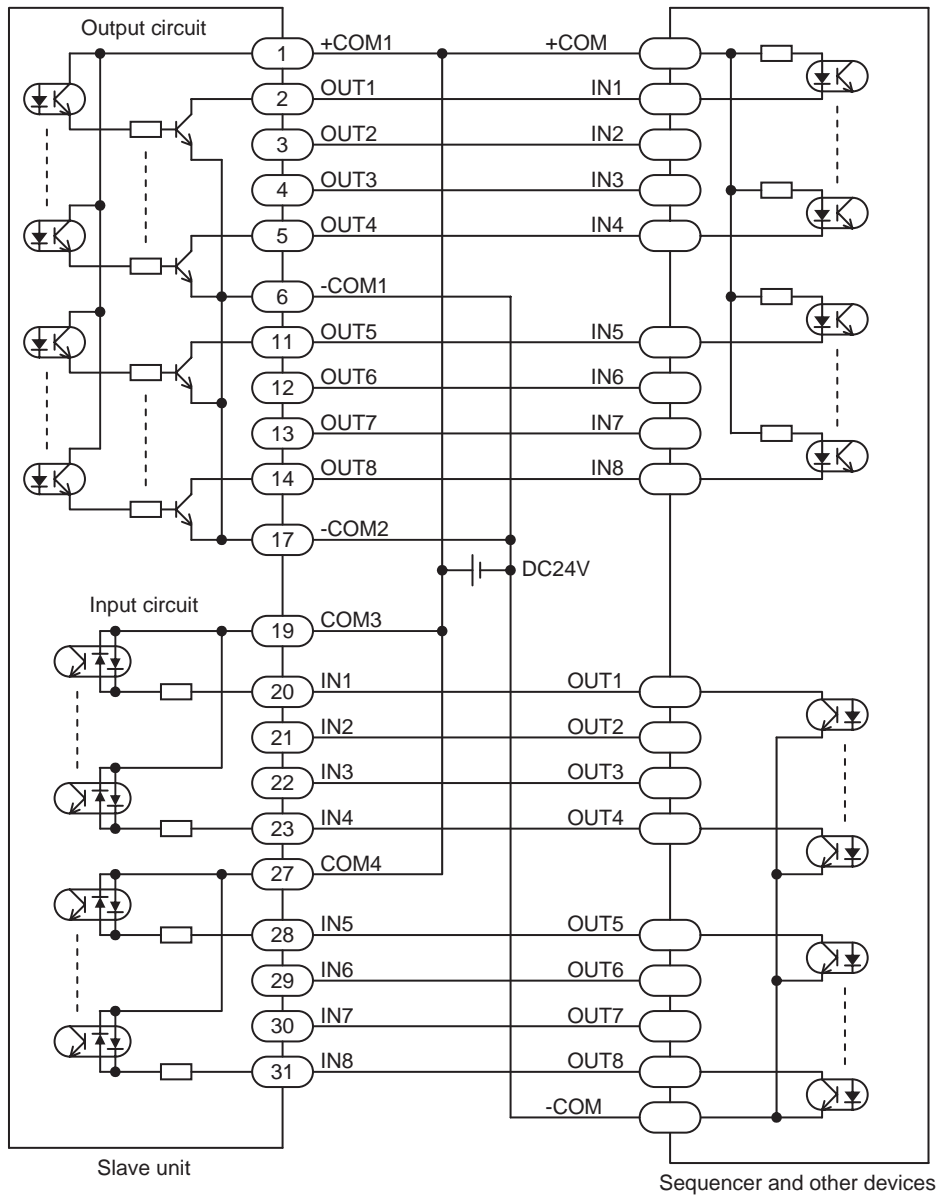

Notes

- -COM1 and -COM2 are connected internally.
- COM3 and COM4 are not connected internally.

Slave Units CA25-S10, CA25-S40, CA25-S80

[Input/Output Connection Example]

PNP Input/Output

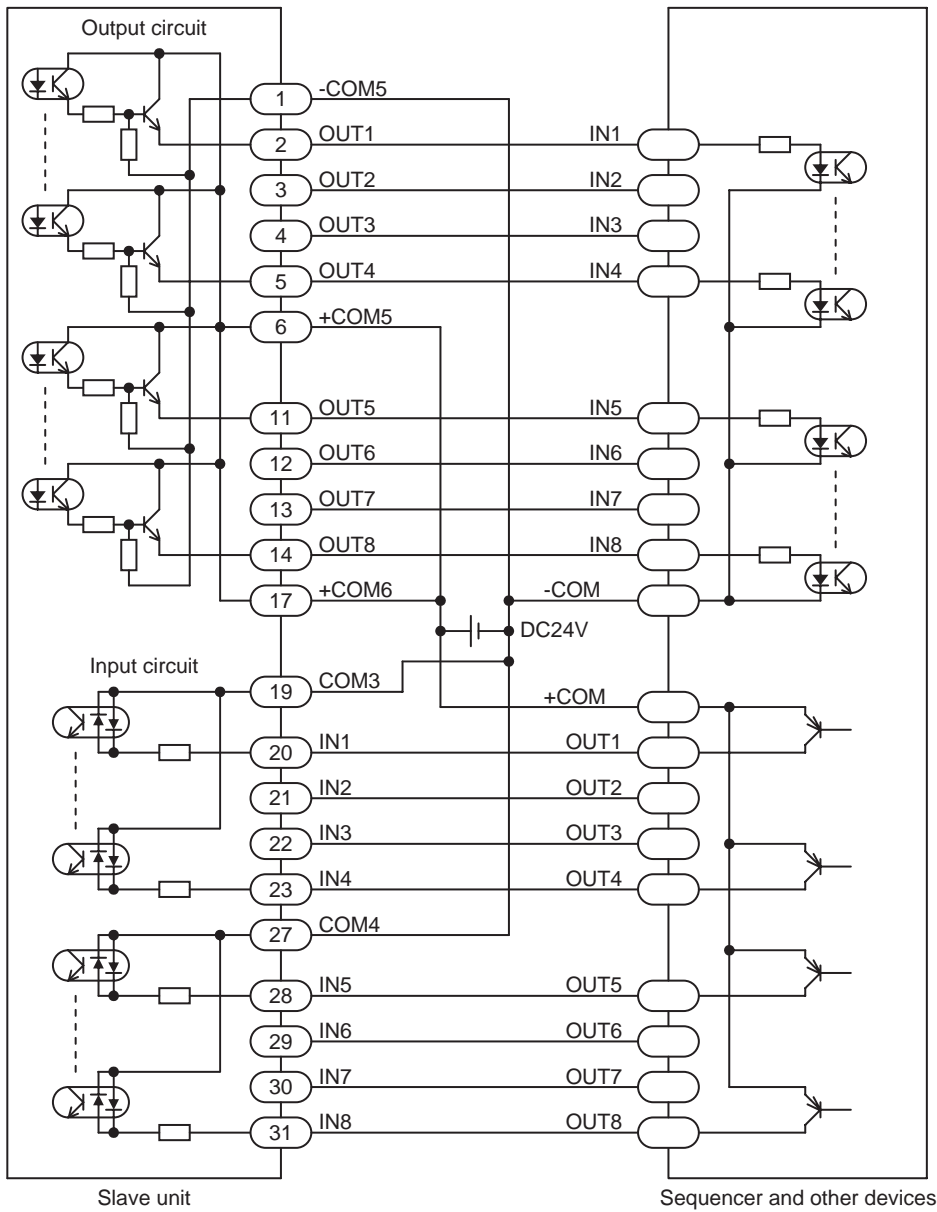

Notes

- +COM5 and +COM6 are connected internally.
- COM3 and COM4 are not connected internally.

How to Calculate Tact (Cycle) Time

The tact time (cycle time) of a single robot can be figured out from the following calculations. It provides only a yardstick, however, because the time thus calculated differs more or less from actual time.

The calculation comes in the two methods; Example calculation 1 (when equi-speed interval is included) and Example calculation 2 (when an axis starts decelerating during acceleration). Either calculation method is selectable according to the relationship between travel distance, specified speed and specified acceleration/deceleration time.

[1] When "travel distance > specified speed (V) × specified acceleration/deceleration time (ACC)" ⇒ Example calculation 1

[2] When "travel distance ≤ specified speed (V) × specified acceleration/deceleration time (ACC)" ⇒ Example calculation 2

- For the acceleration/deceleration time, refer to the relationship between acceleration/deceleration and load as shown in the next page.
- For the acceleration/deceleration time and maximum speed under maximum payload, refer to the specifications of each axis type.

Example calculation 1

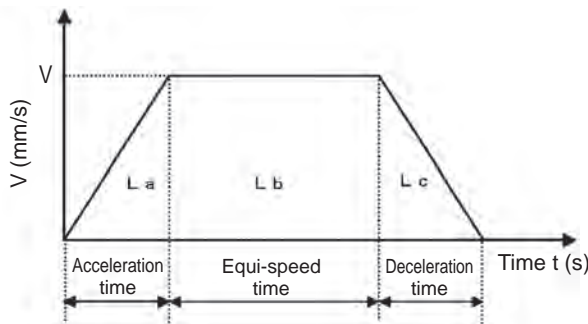

L_a = Travel distance at acceleration (mm)
 L_b = Travel distance at equi-speed
 L_c = Travel distance at deceleration (mm)
 L_t = Equi-speed time (s)
 L = Travel distance (mm) = $L_a + L_b + L_c$
 V = Specified speed (mm/s)
 t = Time (s)
 Acc = Specified acceleration/deceleration time (s)

<Operating conditions>

Specified speed : $V = 1,000$ mm/s

Specified acceleration/deceleration time : $ACC = 0.3$ s

Travel distance: $L = 400$ mm

$$L_a = \frac{1}{2} \times V \times Acc = \frac{1}{2} \times 1000 \times 0.3 = 150 \text{ mm}$$

$$L_c = \frac{1}{2} \times V \times Acc = \frac{1}{2} \times 1000 \times 0.3 = 150 \text{ mm}$$

$$L_t = \frac{L - (L_a + L_c)}{V} = \frac{400 - (150 + 150)}{1000} = 0.1 \text{ s}$$

$$\begin{aligned} \text{Tact time} &= \text{Acceleration time} + \text{Equi-speed time} + \text{Deceleration time} \\ &= 0.3 + 0.1 + 0.3 \\ &= \underline{0.7 \text{ sec}} \end{aligned}$$

Example calculation 2

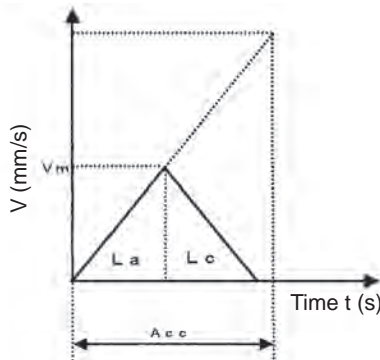

V = Specified speed (mm/s)
 V_m = Real maximum speed (mm/s)
 L = Travel distance (mm)
 L_a = Travel distance at acceleration (mm)
 L_c = Travel distance at deceleration (mm)
 Acc = Specified acceleration/deceleration time (s)
 t = Time (s)

$$L_a = \frac{L}{2} = \frac{200}{2} = 100 \text{ mm}$$

$$L_c = \frac{L}{2} = \frac{200}{2} = 100 \text{ mm}$$

$$\begin{aligned} \text{Tact time} &= 2 \sqrt{\frac{L \times ACC}{V}} = 2 \sqrt{\frac{200 \times 0.3}{1000}} \\ &= \underline{0.49 \text{ sec}} \end{aligned}$$

<Operating conditions>

Specified speed : $V = 1,000$ mm/s

Specified acceleration/deceleration time : $ACC = 0.3$ s

Travel distance: $L = 200$ mm

Relationship between acceleration/deceleration and load

- For the pause time after travel, 1.0 s or over is necessary.
- Vibration may be caused under some installation conditions.
- The payload given above is exerted just above the slider.
- The lower row of the acceleration/deceleration time applies to the models marked by *1.

Payload (kg)

Drive system	Installation direction	Type	Set speed (mm/s)	Lead (mm)	Acceleration/deceleration time(s) (Note 1)					
					0.12 (0.09)	0.24 (0.18)	0.36 (0.27)	0.48 (0.36)	0.6 (0.45)	0.72 (0.54)
Ball screw type	Horizontal	BE10E	1200	20	7	11	20	20	20	20
			600	10	20	25	30	30	30	30
			300	5	25	35	50	50	50	50
		BE30E	1200	20	12	18	20	20	20	20
			600, 300	10, 5	25	35	50	50	50	50
			1200	20	25	35	40	40	40	40
		BE30F	600, 300	10, 5	50	65	80	80	80	80
			1200	20	25	40	60	60	60	60
			600, 300	10, 5	50	75	100	100	100	100
		BE50F	1200	20	40	70	100	100	100	100
			600, 300	10, 5	60	100	150	150	150	150
			2400	40	7	14	25	25	25	25
		BE60G	1200	20	40	70	100	100	100	100
			600	10	60	100	150	150	150	150
			1800	40	12	28	50	50	50	50
		BE60J *1	900	20	60	130	200	200	200	200
			450	10	100	180	250	250	250	250
			1200	20	3	4	5	5	5	5
	Vertical	BE10E	600	10	6	9	12	12	12	12
			300	5	17	20	22	22	22	22
			1200	20	3	4	5	5	5	5
		BE30E	600	10	6	9	12	12	12	12
			300	5	17	20	22	22	22	22
			1200	20	6	7	10	10	10	10
		BE30F	600	10	14	16	20	20	20	20
			300	5	30	35	40	40	40	40
			1200	20	8	10	12	12	12	12
		BE50F	600	10	15	20	25	25	25	25
			300	5	30	40	50	50	50	50
			1200	20	20	22	25	25	25	25
		BE50G	600	10	30	40	50	50	50	50
			300	5	40	50	60	60	60	60
			1200	20	20	22	25	25	25	25
		BE60G	600	10	30	40	50	50	50	50
			900	20	30	40	50	50	50	50
			450	10	40	70	100	100	100	100

Payload (kg)

Drive system	Installation direction	Type	Set speed (mm/s)	Lead (mm)	Acceleration/deceleration time(s) (Note 1)					
					0.1	0.2	0.3	0.4	0.5	0.6
Ball screw type	Horizontal	BET5D	800	12	4	5	6	6	6	6
			400	6	8	10	15	15	15	15
		BET7D	800	12	4	5	12	12	12	12
	400		6	10	15	30	30	30	30	
	Vertical	BET5D	800	12	1	2	3	3	3	3
			400	6	2	3	4	4	4	4
BET7D		800	12	1	2	4	4	4	4	
	400	6	3	5	8	8	8	8		
Timing belt type	Horizontal	BE10E	1000	21	5	10	15	15	15	15
			2000	42	2	4	6	8	10	10
		BE30E	1000	21	5	10	15	15	15	15
			2000	42	6	10	12	14	20	20
		BE50F	1000	21	10	20	40	40	40	40
			2000	42	7	10	12	14	20	20

Note 1: The acceleration/deceleration time is the time until an axis reaches the set speed as given in the table.

[BA-III Series]Component List per Unit

Single axis control system (For details, see the pages for each unit and fill in this sheet.)

	Guide No.	Code designation	Q'ty
	Unit name		
1	Actuator (axis)	BE <input type="text"/> <input type="text"/> - <input type="text"/> - <input type="text"/> <input type="text"/> <input type="text"/> - <input type="text"/>	
2	Controller cable	BE10 - CC - M <input type="text"/>	
3	Controller (master unit)	CA20 - M <input type="text"/>	
4	I/O cable	CA10 - IC - A <input type="text"/>	
5	Regenerative discharge unit	ABSU - <input type="text"/> 000	
6	Teach pendant	TPH - 4C	

Notes on completing this sheet:

* Fill in the necessary numbers and letters in the boxes together with required quantities.

* Packing charge, transportation fee and excise tax will be quoted separately.

* This component list may not be adequate, depending on the user's requirements.

[BA-III Series] Component List per Unit

2-axis, 3-axis or 4-axis control system (For details, see the pages for each unit and fill in this sheet.)

	Guide No.	Code designation	Q'ty
	Unit name		
1	Actuator (axis 1)	BE <input type="text"/> <input type="text"/> - <input type="text"/> - <input type="text"/> <input type="text"/> <input type="text"/> - <input type="text"/>	
	Actuator (axis 2)	BE <input type="text"/> <input type="text"/> - <input type="text"/> - <input type="text"/> <input type="text"/> <input type="text"/> - <input type="text"/>	
	Actuator (axis 3)	BE <input type="text"/> <input type="text"/> - <input type="text"/> - <input type="text"/> <input type="text"/> <input type="text"/> - <input type="text"/>	
	Actuator (axis 4: R-axis)	BE00D - <input type="text"/> - <input type="text"/>	
2	Axis combination bracket	BA <input type="text"/> - BK - <input type="text"/>	
		BA <input type="text"/> - BK - <input type="text"/>	
3	Controller cable	BE10 - CC - M <input type="text"/>	
		BE10 - CC - M <input type="text"/>	
		BE10 - CC - M <input type="text"/>	
		BE10 - CC - M <input type="text"/>	
4	CN box	BA10 - BX - <input type="text"/>	
		BA10 - BX - <input type="text"/>	
		BA10 - BX - <input type="text"/>	
5	Flexible tube, Flexible duct	BA10 - <input type="text"/> - <input type="text"/> <input type="text"/>	
		BA10 - <input type="text"/> - <input type="text"/> <input type="text"/>	
		BA10 - <input type="text"/> - <input type="text"/> <input type="text"/>	
6	Tube tray, Flexible tray	BA10 - TT - <input type="text"/> <input type="text"/>	
7	Cable grip	BA10 - CG - M2 <input type="text"/>	
8	Strain relief	BA10 - SC - A02	
9	Controller (master)	CA25 - M <input type="text"/> 0 - <input type="text"/> C	
10	Controller (slave)	CA25 - S <input type="text"/> 0 - <input type="text"/> XX	
11	Link cable	CA10 - LC - A <input type="text"/>	
12	I/O cable	CA10 - IC - A <input type="text"/>	
13	Regenerative discharge unit	ABSU - <input type="text"/> 000	
14	Teach pendant	TPH - 4C	

Notes on completing this sheet:

* Fill in the necessary numbers and letters in the boxes together with required quantities.

* Packing charge, transportation fee and excise tax will be quoted separately.

* This component list may not be adequate, depending on the user's requirements.

TOSHIBA MACHINE CO., LTD. HEAD OFFICE



Presented by: Absolute Gauge Technologies
sales@absolutegauge.com;
www.absolutegauge.com,
Toronto: 416 754 3168, Montreal: 514 695 5147,
Toll Free: 1 888 754 7008



Before operating the industrial robot, read through and completely understand the instruction manuals.

■ The contents included in this catalog are subject to change without prior notice to reflect improvements.