

# M2-iLAN-1-21/16

## Laser Scanner

Small and compact  
Seam tracking in robotic welding processes

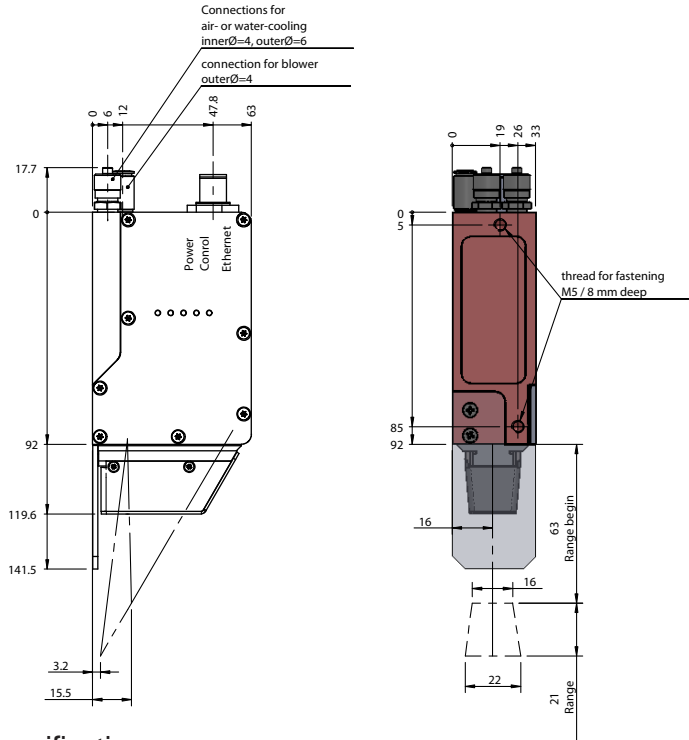

### Specifications

Sensor	M2-iLAN-1-21/16
Range Z	21 mm
Range begin Z	63 mm
Begin of scan range X	16 mm
End of scan range X	22 mm
Resolution Z *	0.021 mm
Resolution X *	0.038 mm
Laser protection class	2, optionally 3R
Linearity	0.2 % of range
Sampling rate	100 Hz
Specials	feeler gage, elapsed hour counter, serial number and sensor data readable
Light source	Laser, wave length 658 nm, red visible
Ambient light	5,000 Lux (approx. 40 mm next to weld spot)
Operating time	Laser diode: 50.000 h
max. Vibration	5 g up to 1 kHz
Operating temperature	0 °C ... +40 °C (up to 200°C ambient temperature with water cooling)
Storage temperature	-20 °C ... +70 °C
Humidity	< 90% RH
Protection class	IP 64
Power supply	8 - 30 V, P <sub>w</sub> = 15 W
Surface	white to black, shiny, high mirroring

\* Measurement on matt white, diffusely reflecting surface

The M2-iLAN-1-21/16 controls the position of the welding head constantly during the welding process and transmits the measured data via Ethernet to the PLC. So the head will always be placed in the right position to the welding joint. Due to its compact design the scanner is particularly suitable for use in confined spaces.

Error and technical modification reserved

DB-M2iLAN-1-2116\_1-01-E