

SNDH-T Series

Quadrature General Industrial Speed and Direction Sensors

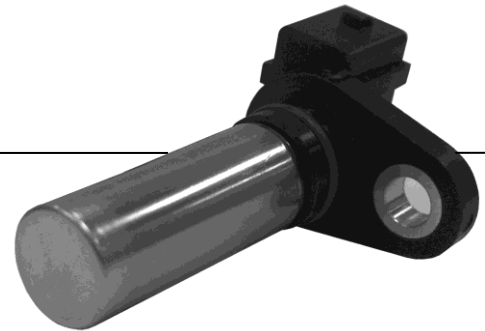

DESCRIPTION

The SNDH-T Series is a dual differential hall sensor that provides speed and direction information using a quadrature output with signals 90° phase shifted from each other. Target direction is determined by output lead/lag phase shifting.

This product is designed for applications where extremely high resolution is required at wide frequency ranges, 1 kHz to 15 kHz, and large air gaps. BiCMOS (bipolar complementary metal-oxide-semiconductor) Hall-effect technology, using advanced digital signal processing for dynamic off-set cancellation, provides enhanced air gap performance and phase shift accuracy over most conditions.

FEATURES

- Hall-effect magnetic sensing technology
- Dual differential Hall provides enhanced target resolution
- Advanced performance dynamic offset self calibration
- Air gap up to 2 mm [0.08 in]
- Near zero speed
- Automotive under-the-hood packaging integrity
- EMI hardened
- High frequency switching capability (1 Hz to 15 kHz)
- -40 °C to 150 °C [-40 °F to 302 °F] continuous operating temperature
- Multiple connector options
- Short circuit protection
- Reverse voltage protection
- Open collector output
- Low jitter output
- O-ring seal

Unique patented (pending) IC (integrated circuit) packaging provides output phase shift tolerancing with enhanced accuracy.

The robust package is automotive under-the-hood grade for most environmental conditions as well as EMI (electromagnetic interference) hardened. Multiple connection options, including wire harness and integral connector versions using AMP super seal or AMP Jr. Timer connectors, are available. Package design includes an o-ring seal for pressure applications and a fixed mounting flange.

POTENTIAL APPLICATIONS

- Steering position
- Tachometers/counters
- Encoders
- Speed and direction of gears and shafts in transmissions, hydraulic motors, pumps, and gear boxes

SNDH-T Series

Table 1. Specifications

Characteristic	Parameter	Note
Sensing air gap	0 mm to 2,0 mm [0 in to 0.08 in]	may achieve larger gaps with testing of actual target
Target tooth width	2,0 mm [0.08 in] (recommended)	other geometry may be suitable
Target slot width	2,0 mm [0.08 in] (recommended)	other geometry may be suitable
Tooth height	>3,0 mm [0.12] (recommended)	shorter tooth heights may limit max. air gap performance
Target width	>5,0 mm [0.20] (recommended)	narrow targets may limit axial offsets
Sensor misposition to target	±1,5 mm [0.06]	dependent on target geometry
EMI radiated immunity	100 V/m peak	400 Hz to 2 GHz
EMI bulk current injection	60 mA	20 MHz to 400 MHz
EMI ESD	16/8 KV air/contact	against the connector (150 pF, 330 Ohm)
EMI fast transient burst	EN61000-4-4 Level 4	—
Operating temperature	-40 °C to 150 °C [-40 °F to 302 °F]	continuous
Thermoshock	-40 °C to 150 °C [-40 °F to 302 °F]	—
Humidity	168 hr	95% humidity at 90 °C [194 °F]
Salt fog	96 hr	DIN IEC 6872-11
Thermosaline dunk	5 dunks	105 °C to 0 °C [221 °F to 32 °F] air to liquid, 5% saline
High temp exposure with power	1000 hr at 150 °C [302 °F]	—
Mechanical shock	50 g	—
Vibration	30 g, 10 Hz to 2 kHz	—
Resistance to fluids	general automotive under the hood fluids	—
Supply voltage	4.5 V to 18 V	—
Max. continuous supply voltage	18 V	—
Reverse voltage	-18 V max.	continuous
Current (normal)	13.6 mA	all conditions
Current (max.)	18 mA	all conditions
Short circuit protection	80 mA	—
Output signal type	square wave	two channel, phase shifted by 90°, either channel can lead or lag, push/pull
Duty cycle	50% ±10%	—
Phase shift	90° ±20°	using recommended target tooth/slot
Output high	≥Vs -0.5 V	—
Output low	≤0.5 V	—
Load current	20 mA max.	each output at all conditions
Output low	≤0.5 V	—
Rise time	10 μs typ.	dependent on load resistor
Fall time	1 μs typ.	—
Frequency	1 Hz to 15 kHz	higher frequencies about 10 kHz may be dependent on target geometry and air gap

Figure 1. Wiring Diagram

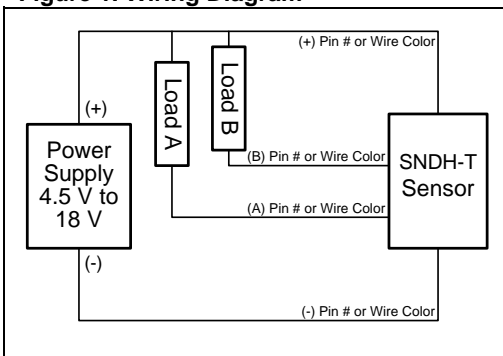

Figure 2. Sensor Output

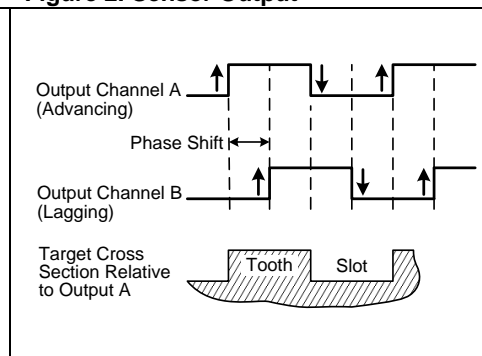
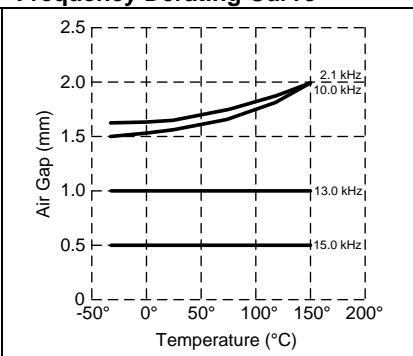
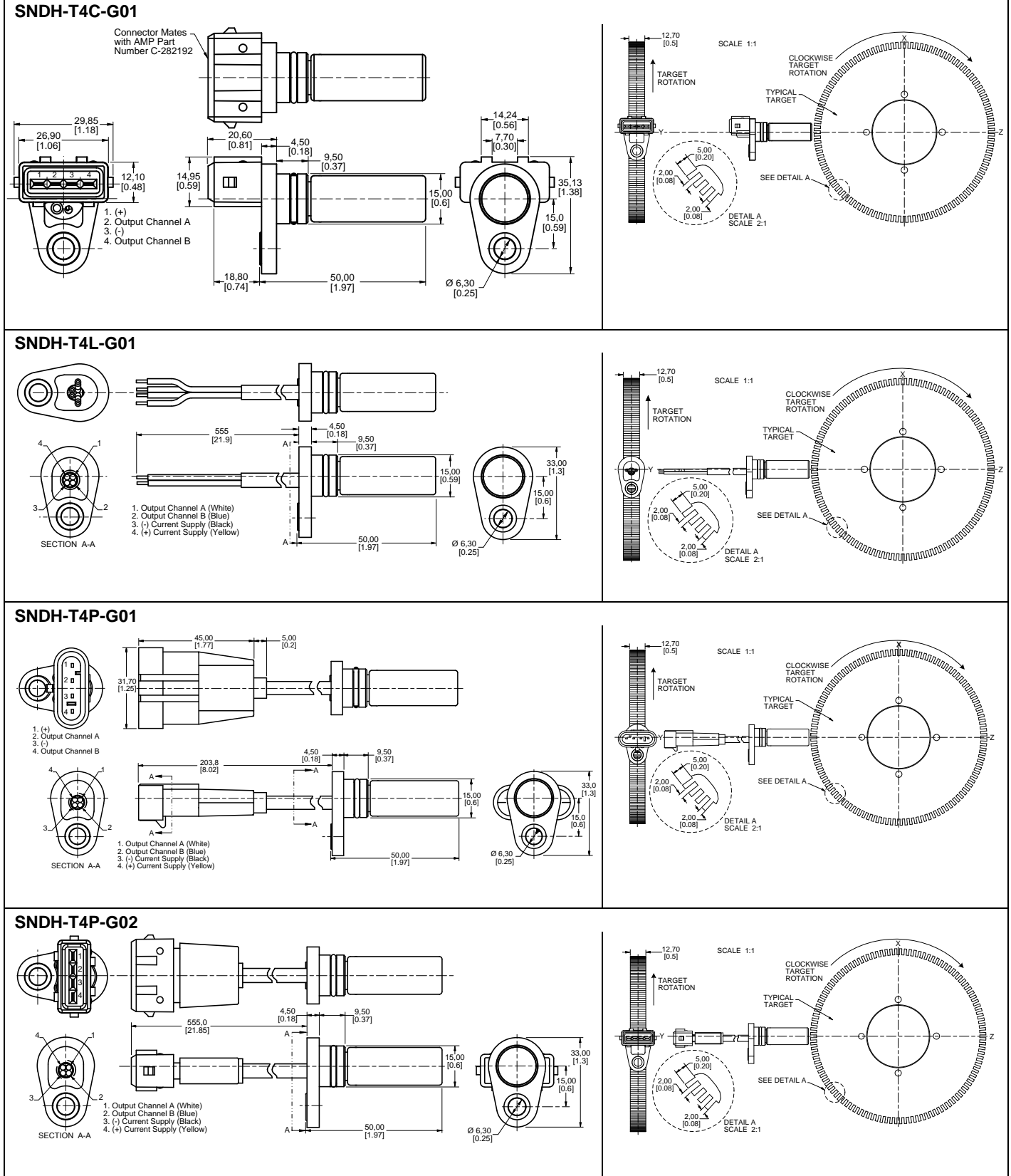

Figure 3. Temperature Air Gap Frequency Derating Curve



Quadrature Speed and Direction Sensors

Figure 4. Mounting Dimensions and General Mounting Geometry (For reference only: mm [in.])



ORDER GUIDE

Catalog Listing	Description
SNDH-T4C-G01	SNDH-T Series, dual hall speed and position sensor, 4 wire output, connector
SNDH-T4L-G01	SNDH-T Series, dual hall speed and position sensor, 4 wire output, leadwire
SNDH-T4P-G01	SNDH-T Series, dual hall speed and position sensor, 4 wire output, pigtail with rectangular connector
SNDH-T4P-G02	SNDH-T Series, dual hall speed and position sensor, 4 wire output, pigtail with oval connector

WARNING

PERSONAL INJURY

DO NOT USE these products as safety or emergency stop devices or in any other application where failure of the product could result in personal injury.

Failure to comply with these instructions could result in death or serious injury.

WARRANTY/REMEDY

Honeywell warrants goods of its manufacture as being free of defective materials and faulty workmanship. Honeywell's standard product warranty applies unless agreed to otherwise by Honeywell in writing; please refer to your order acknowledgement or consult your local sales office for specific warranty details. If warranted goods are returned to Honeywell during the period of coverage, Honeywell will repair or replace, at its option, without charge those items it finds defective. **The foregoing is buyer's sole remedy and is in lieu of all other warranties, expressed or implied, including those of merchantability and fitness for a particular purpose. In no event shall Honeywell be liable for consequential, special, or indirect damages.**

While we provide application assistance personally, through our literature and the Honeywell web site, it is up to the customer to determine the suitability of the product in the application.

Specifications may change without notice. The information we supply is believed to be accurate and reliable as of this printing. However, we assume no responsibility for its use.

WARNING

MISUSE OF DOCUMENTATION

- The information presented in this product sheet is for reference only. Do not use this document as a product installation guide.
- Complete installation, operation, and maintenance information is provided in the instructions supplied with each product.

Failure to comply with these instructions could result in death or serious injury.

SALES AND SERVICE

Honeywell serves its customers through a worldwide network of sales offices, representatives and distributors. For application assistance, current specifications, pricing or name of the nearest Authorized Distributor, contact your local sales office or:

E-mail: info.sc@honeywell.com

Internet: www.honeywell.com/sensing

Phone and Fax:

Asia Pacific +65 6355-2828
+65 6445-3033 Fax
Europe +44 (0) 1698 481481
+44 (0) 1698 481676 Fax
Latin America +1-305-805-8188
+1-305-883-8257 Fax
USA/Canada +1-800-537-6945
+1-815-235-6847
+1-815-235-6545 Fax

Sensing and Control
Honeywell
1985 Douglas Drive North
Golden Valley, MN 55422

www.honeywell.com/sensing



000641-3-EN IL50 GLO Printed in USA
November 2009
Copyright © 2009 Honeywell International Inc. All rights reserved.

Presented by: Absolute Gauge Technologies
sales@absolute-gauge.com; www.absolute-gauge.com,
Toronto: 416 754 3168, Montreal: 514 695 5147, Toll Free: 1 888 754 7008

Honeywell