

MVL-KF1228M-12MPE

1.1" 12mm 12MP FA LENS

KF-E series FA Lens are optimized for machine vision light sources and sensor, with high resolution, excellent image quality, high transmittance and good stability. Featured with fixed focal length, manual aperture and compact size, it is suitable for machine vision industry applications and ideal for industrial cameras.



Key Features

- Ultra high resolution and consistency of image clarity
- Lower distortion
- Super high image peripheral brightness ratio
- Excellent optical properties are maintained at different object distances

Distortion

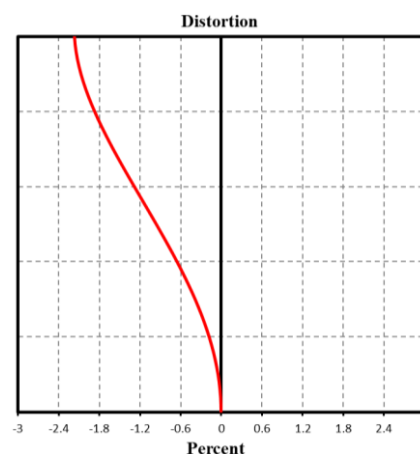

MTF

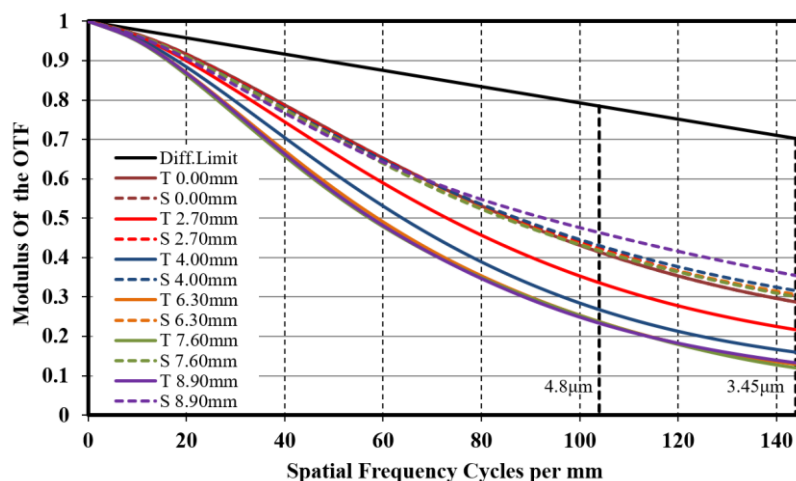

Relative Illumination

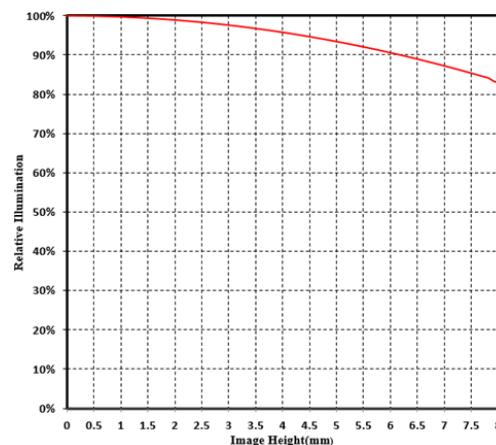

Note: The above curves are the simulate results based on F2.8, $\beta = -0.024$, WD=500 mm.



Specification

Model	MVL-KF1228M-12MPE	
Parameter	Fixed focal length, Manual iris, 12MP, FA lens	
Performance		
Focal Length	12 mm	
F-Number	F2.8 ~ F22	
Image Size	Φ17.6 mm(1.1")	
Distortion	1.5%	
Minimum Object Distance	0.1 m	
Field of View	D (17.52mm): 66.7° H (14.14mm): 57° V (10.35mm): 45°	
Mechanical		
Iris Control	Manual	
Focus Control	Manual	
Mount	C-Mount	
Flange Back Length	17.526 mm	
Dimension	Φ48 × 71.32 mm	
Weight	245 g	
Temperature	-10 ~ 50°C	
General		
Certification	RoHS2.0	

Dimension

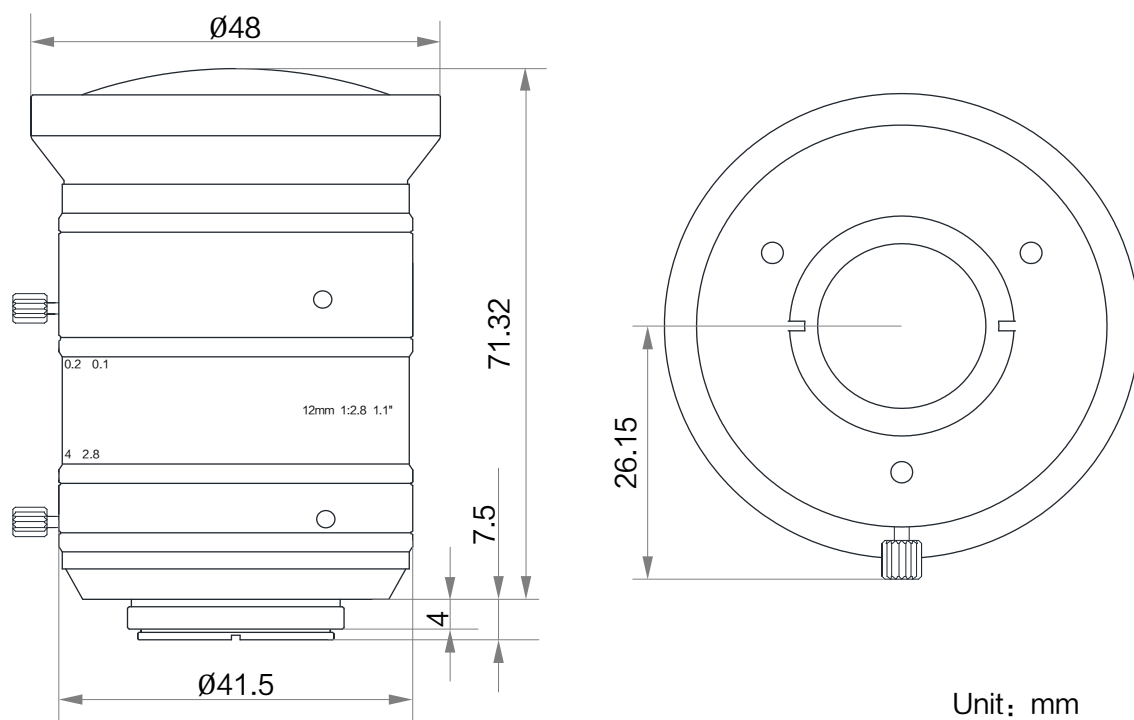

Field of View

Extension (mm)	Working Distance(mm)		Magnification	Field of View(mm)					
				1.1" (14.14mm×10.35mm)		1" (12.45mm×9.83mm)		2/3" (8.45mm×7.07mm)	
				H	V	H	V	H	V
5	near	6.42	-0.523	27.00	19.70	25.00	19.00	17.00	12.75
	far	8.12	-0.487	29.00	21.20	26.00	19.90	18.00	13.50
2	near	27.65	-0.272	52.00	38.10	47.00	35.98	33.00	24.75
	far	34.45	-0.236	60.00	43.94	55.00	42.10	37.00	27.75
1	near	47.19	-0.188	75.00	54.93	68.00	52.00	47.00	35.25
	far	63.34	-0.150	94.00	68.84	85.00	65.00	59.00	44.25
0		100	-0.100	144.95	106.1	127.63	100.77	86.62	72.48
		150	-0.071	198.44	145.25	174.37	137.68	118.35	99.02
		200	-0.057	250.77	183.55	220.35	173.98	149.56	125.13
		250	-0.045	312.08	228.43	274.23	216.52	186.12	155.73
		300	-0.039	364.22	266.60	320.05	252.70	217.22	181.75
		350	-0.033	425.47	311.43	373.87	295.20	253.75	212.31
		400	-0.029	481.91	352.74	423.47	334.35	287.41	240.48
		450	-0.026	538.72	394.32	473.38	373.76	321.29	268.82
		500	-0.024	595.31	435.74	523.11	413.03	355.04	297.06
		550	-0.021	652.92	477.91	573.73	453.00	389.40	325.81
		600	-0.020	711.97	521.14	625.63	493.97	424.62	355.28
		650	-0.019	765.85	560.58	672.97	531.35	456.76	382.16
		700	-0.017	823.74	602.95	723.84	571.51	491.28	411.05
		800	-0.015	938.30	686.80	824.50	650.99	559.60	468.21
	900	-0.014	1049.50	768.20	922.22	728.15	625.93	523.70	
	1000	-0.012	1151.89	843.15	1012.20	799.19	686.99	574.80	

HIKROBOT

Hangzhou Hikrobot Co. Ltd.
 en.hikrobotics.com