

MV-CB060-10GM/C

6 MP 1/1.8" CMOS GigE Board Level Camera

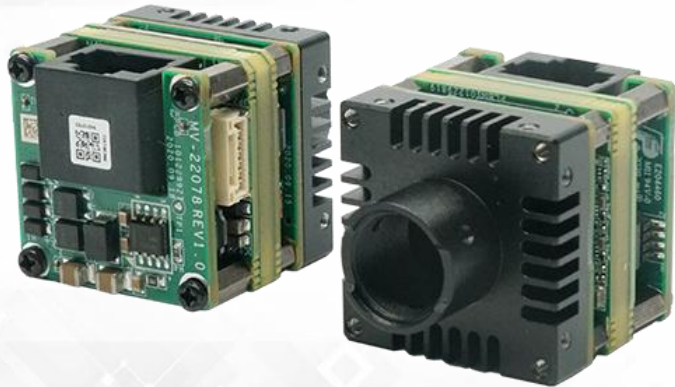

GEN*i*CAM

GIG*E*
VISION

Introduction

MV-CB060-10GM/C camera adopts Sony® IMX178 sensor to provide high-quality images. It uses GigE interface to transmit images in real time, and its max. frame rate can reach 19.1 fps in full resolution, and reach 30.7 fps when the image compression mode is enabled.

Key Feature

- Supports auto or manual adjustment of gain, exposure time, white balance, manual adjustment of Gamma correction, LUT, Binning, etc.
- Adopts noise reduction and image compression functions to provide high-quality images.
- Adopts GigE interface and max. transmission distance of 100 meters without relay.
- Compatible with GigE Vision V2.0 Protocol, GenICam Standard, and third-party software based on the protocol and standard.

Applicable Industry

Electronic semiconductor, factory automation, logistics, bottle detection, medicine packing, etc.

Available Model

- Mono camera with M12-mount: MV-CB060-10GM-S
- Color camera with M12-mount: MV-CB060-10GC-S
- Mono camera with C-mount: MV-CB060-10GM-C
- Color camera with C-mount: MV-CB060-10GC-C

Sensor Quantum Efficiency

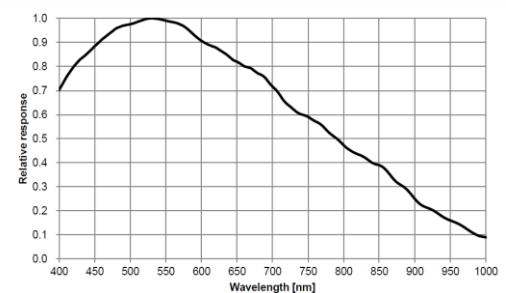

MV-CB060-10GM

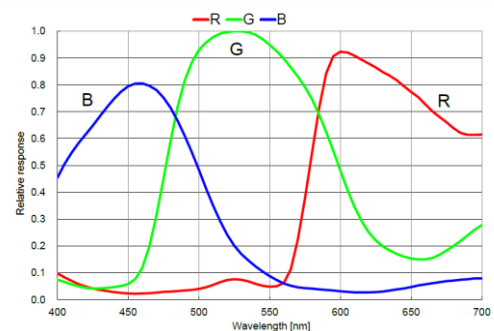

MV-CB060-10GC



Specification

Model	MV-CB060-10GM	MV-CB060-10GC
Camera		
Sensor type	CMOS, rolling shutter	
Sensor model	Sony® IMX178	
Pixel size	2.4 μm × 2.4 μm	
Sensor size	1/1.8"	
Resolution	3072 × 2048	
Max. frame rate	19.1 fps @3072 × 2048	
	30.7 fps @3072 × 2048 (image compression mode enabled)	
Dynamic range	71.3 dB	
SNR	41.3 dB	
Gain	0 dB to 24 dB	
Exposure time	25 μs to 2.5 sec	
Exposure mode	Off/Once/Continuous exposure mode	
Mono/color	Mono	Color
Pixel format	Mono 8/10/10p/12/12p	Mono 8/10/12, Bayer RG 8/10/10p/12/12p, YUV422Packed, YUV422_YUYV_Packed, RGB 8, BGR 8
Binning	Supports 1 × 1, 2 × 2	
Decimation	Supports 1 × 1, 2 × 2, 4 × 4	
Reverse image	Supports horizontal and vertical reverse image output	
Electrical features		
Data interface	Gigabit Ethernet, compatible with Fast Ethernet	
Digital I/O	6-pin connector provides power and I/O, including non-isolated input × 1 (Line 0), non-isolated output × 1 (Line 1), and bi-directional non-isolated I/O × 1 (Line 2).	
Power supply	9 VDC to 24 VDC, supports PoE	
Power consumption	Typ. 2.3 W@12 VDC	Typ. 2.6 W@12 VDC
Mechanical		
Lens mount	C-mount or M12-mount	
Dimension	29 mm × 29 mm × 30.2 mm (1.1" × 1.1" × 1.2")	
Weight	Approx. 45 g (0.1 lb.)	
Temperature	Working temperature: 0 °C to 50 °C (32 °F to 122 °F)	
	Storage temperature: -30 °C to 70 °C (-22 °F to 158 °F)	
Humidity	20% to 80% RH, non-condensing	
General		
Client software	MVS or third-party software meeting with GigE Vision Protocol	
Operating system	32/64-bit Windows XP/7/10, 32/64-bit Linux and 64-bit MacOS	
Compatibility	GigE Vision V2.0, GenICam	
Certification	CE, FCC, RoHS, KC	

Dimension

Camera with C-mount:

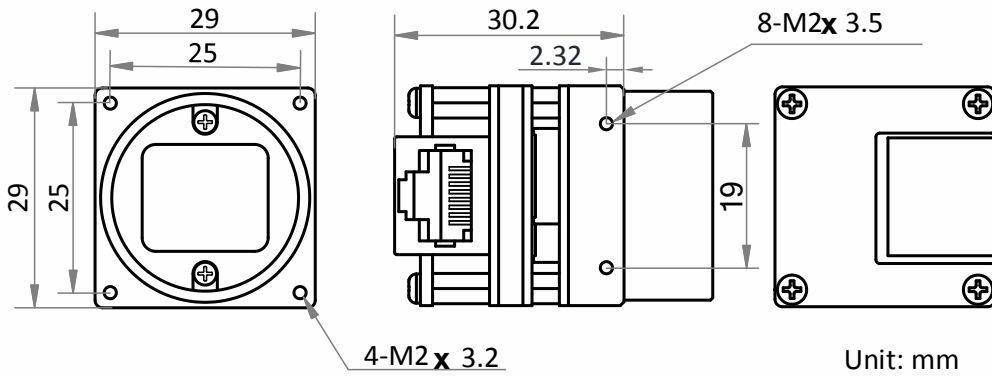

Camera with M12-mount:

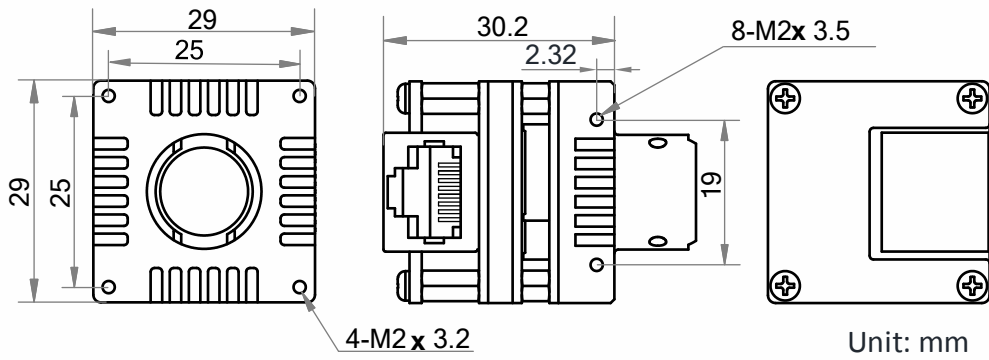

HIKROBOT

Hangzhou Hikrobot Co., Ltd.
 en.hikrobotics.com

© Hangzhou Hikrobot Co., Ltd. All Rights Reserved.

Hangzhou Hikrobot does not tolerate any infringement. Any organization or individual may not imitate or reproduce in whole or in part of the content. The data herein is based on Hikrobot's internal evaluation. Actual data may vary depending on specific configuration and operating condition. The information herein is subject to change without notice. All the content has been checked conscientiously. Nevertheless, Hikrobot shall not be liable to damages resulting from errors, inconsistencies or omissions.