

4-20 mA & Serial Data Output Transmitter for Position or Rate from Quadrature Encoders

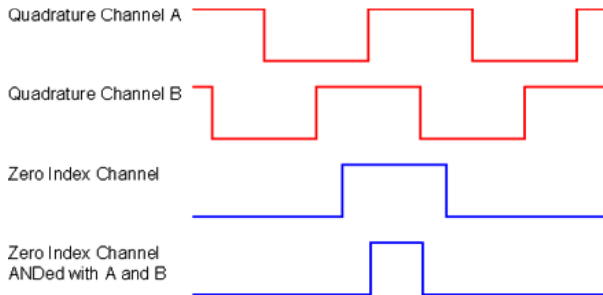

Features

- 4-20 mA, 0-20 mA, 0-10V or -10V to +10V transmitter output, 16 bits, isolated
- RS232 or RS485 serial data output, Modbus or Laurel ASCII protocol, isolated
- Dual 120 mA solid state relays for alarm or control, isolated
- Accepts low-level differential or single-ended 5V logic level signals from shaft encoders, linear encoders, incremental encoders or optical encoders
- Programmable for position, angle or rate
- Quadrature count x1, x2 or x4 with combined pulse rate to 250 kHz
- Zero channel input
- Analog output resolution 0.0015% of span (16 bits), accuracy $\pm 0.02\%$ of span
- 5V, 10V or 24V dc transducer excitation output, isolated
- Universal 85-264 Vac / 90-300 Vdc or 10-48 Vdc / 12-32 Vac power



output can track the speed of a moving slab from the RPM of a roller. The update rate for rate is a programmed gate time + 30 ms + 0-2 pulse periods.

Three analog output settings are jumper selectable: 4-20 mA, 0-20 mA or 0-10V. The output tracks the reading up to 999,999 counts that would be transmitted digitally. Output isolation from signal and power grounds eliminates potential ground loop problems. The supply can drive 20 mA into a 500 ohm (or lower) load for 10V compliance, or 10V into a 5K ohm (or higher) load for 2 mA compliance.

Standard features of Laureate transmitters include:

- **4-20 mA, 0-20 mA or 0-10V analog transmitter output**, isolated, jumper-selectable and user scalable. All selections provide 16-bit (0.0015%) resolution of output span and 0.02% output accuracy of a reading from -99,999 to +99,999 counts that is also transmitted digitally. Output isolation from signal and power grounds eliminates potential ground loop problems. The supply can drive 20 mA into a 500 Ω (or lower) load for 10V compliance, or 10V into a 5 k Ω (or higher) load for 2 mA compliance.
- **Serial communications output**, isolated. User selectable RS232 or RS485, half or full duplex. Three protocols are user selectable: Modbus RTU, Modbus ASCII, or Laurel ASCII. Modbus operation is fully compliant with Modbus Over Serial Line Specification V1.0 (2002). The Laurel ASCII protocol allows up to 31 Laureate devices to be addressed on the same RS485 data line. It is simpler than the Modbus protocol and is recommended when all devices are Laureates.
- **Dual solid state relays**, isolated. Available for local alarm or control. Rated 120 mA at 130 Vac or 170 Vdc.
- **Transducer excitation output, isolated.** User selectable 5V@100 mA, 10V@120 mA or 24V@50 mA.
- **Universal 85-264 Vac power.** Low-voltage 10-48 Vdc or 12-32 Vac power is optional.

Easy Transmitter programming is via Laurel's Instrument Setup Software, which runs on a PC under MS Windows. This software can be downloaded from this website at no charge. The required transmitter-to-PC interface cable is available from Laurel (P/N CBL04).

The Laureate quadrature transmitter accepts A & B quadrature encoder signals to provide an analog output that tracks position, length, angle, or rate. The A & B quadrature signals are 90° out of phase, and their phase relationship determines whether up counts (+) or down counts (-) are produced.

One, two or four quadrature transitions may be counted at a maximum combined rate of 250 kHz and be scaled internally to $\pm 999,999$ counts. The input circuitry which may be jumpered for either single-ended input signals or for balanced line driver signals. Anti-jitter circuitry eliminates errors produced by vibration of the encoder. In the event of a power failure, the current total may be stored in non-volatile memory and can be used as the starting point for counting when power resumes. Power fail or zero index capabilities are alternate meter setup choices.

A zero index pulse, if available, is interpreted by the meter as indicating a zero reference for an integral number of revolutions of a rotary shaft encoder or the home position of a linear encoder. It is used by the meter for initializing and to correct for any cumulative pulse count errors. Special circuitry corrects for width of the zero index pulse.

Available for Total or Rate

- **With the Standard main board**, the transmitter totalizes the quadrature counts and then scales the total in software for the output. A zero index Z signal can be added as a third input to the A & B signals. The analog output is generated by an ultra-linear 16-bit (65,536 step) digital-to-analog converter (DAC) for 0.02% output accuracy.
- **With the Extended main board**, the transmitter can be programmed to output either total or rate or rate. For example, the

Specifications

Quadrature Inputs	
Type	Differential or single-ended quadrature
Transitions Monitored	x1, x2 or x4
Max Pulse Rate	250 kHz at x1, 125 kHz at x2, 62.5 kHz at x4
Internal Counts	-999999 to +999999
Position Error	No error contributed by transmitter
Quadrature Position Mode	
Zero Adjust	-999999 to +999999
Span Adjust	0 to ±999999
Quadrature Rate Mode	
Conversion Technique	Inverse period
Output Update Rate	30 ms + 0-2 signal periods
Gate time	Selectable 10 ms to 199.99 s
Time Before Zero Output	Selectable 10 ms to 199.99 s
Time Base Accuracy	Calibrated to ±2 ppm
Zero Adjust	-999999 to +999999
Span Adjust	0 to ±999999
Analog Output (standard)	
Output Levels	4-20 mA, 0-20 mA, 0-10 Vdc, -10 to +10Vdc (user selectable)
Compliance, 4-20 mA	10V (0-500Ω m load)
Compliance, 0-10V	2 mA (5 kΩ load)
Output Resolution	16 bits (65,536 steps)
Output Accuracy	±0.05% of output span
Output Update Rate	25/sec max
Output Isolation	250V rms working, 2.3 kV rms per 1 minute test
Serial Communications (standard)	
Signal Types	RS232 or RS485 (half or full duplex)
Data Rates	300, 600, 1200, 2400, 4800, 9600, 19200 baud
Output Isolation	250V rms working, 2.3 kV rms per 1 min test
Serial Protocols	Modbus RTU, Modbus ASCII, Laurel ASCII
Modbus Modes	RTU or ASCII
Modbus Compliance	Modbus over Serial Line Specification V1.0 (2002)
Digital Addressing	247 Modbus addresses. Up to 32 devices on an RS485 line w/o a repeater.
Dual Relay Output (standard)	
Relay Type	Two solid state relays, SPST, normally open, Form A
Load Rating	120 mA at 140 Vac or 180 Vdc
Sensor Excitation Output (standard)	
Output Levels	5V@100 mA, 10V@120 mA, 24V@50 mA (jumper selectable)
Output Isolation	50V from signal ground
Power Input	
Standard Power	85-264 Vac or 90-300 Vdc
Low Power Option	10-48 Vdc or 12-32 Vac
Power Frequency	DC or 47-63 Hz
Power Isolation	250V rms working, 2.3 kV rms per 1 min test
Power Consumption	2W typical, 3W with max excitation output
Mechanical	
Dimensions	129 x 104 x 22.5 mm case
Mounting	35 mm rail per DIN EN 50022
Electrical Connections	Plug-in screw-clamp connectors

Environmental	
Operating Temperature	0°C to 55°C
Storage Temperature	-40°C to 85°C
Relative Humidity	95% at 40°C, non-condensing
Cooling Required	Mount transmitters with ventilation holes at top and bottom. Leave 6 mm (1/4") between transmitters, or force air with a fan.

Pinout

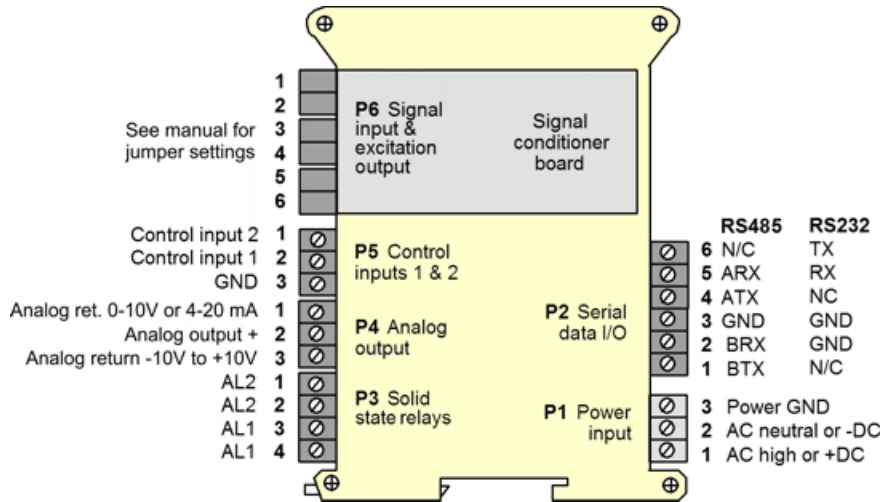

Mechanical

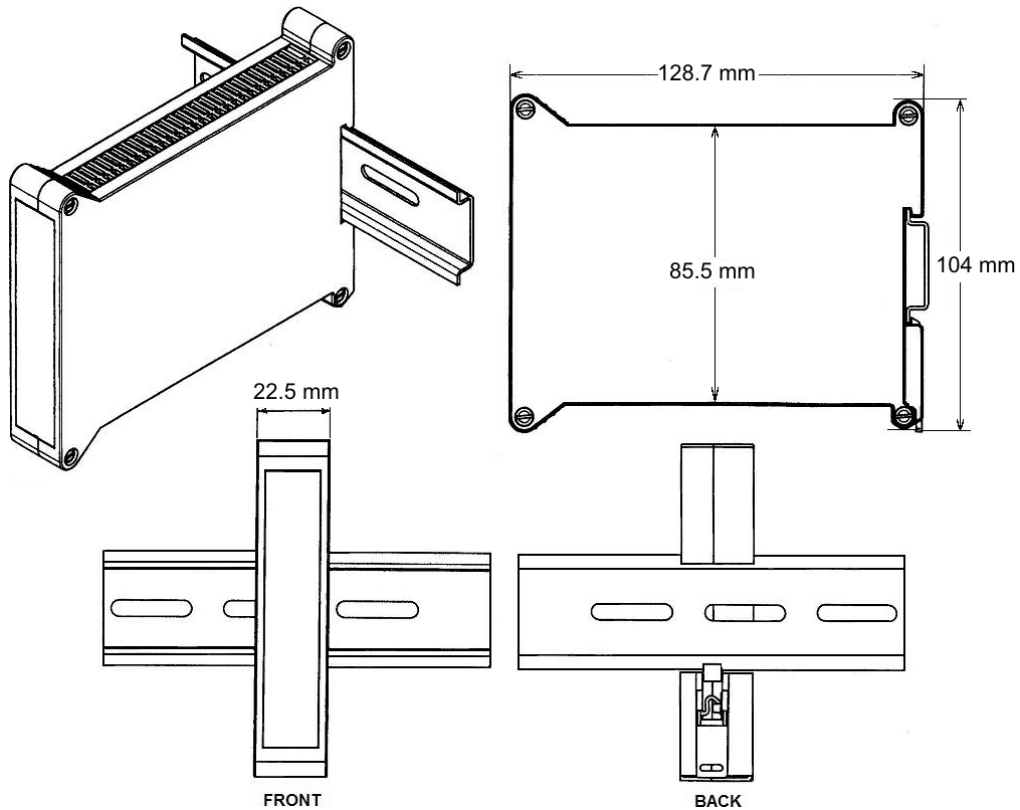

Application Example

Using Quadrature for Cutting to Length	
<p>Motor speed controller</p> <p>Take-up reel</p> <p>Cutting mechanism</p> <p>Sensing wheel with shaft encoder</p> <p>Dispensing reel</p>	<p>Controlling the repetitive cutting of material to length is an excellent application of a Laureate quadrature transmitter or Laureate quadrature meter. The quadrature encoder shares the shaft of a sensing wheel, whose rotation corresponds to lineal displacement of material. The transmitter compares the displacement reading against setpoint information, and then uses its dual relays to first slow down and then cut the material.</p>
Using Quadrature for X-Y Positioning	
<p>Motor</p> <p>Encoder</p>	<p>Accurate X-Y position or rate can be obtained from two shaft encoders, which convert linear position to quadrature signals as a shaft turns. In addition to serving as a transmitter, each Laureate transmitter or meter can use its optional dual relay setpoint capability for closed loop control.</p>
Using Quadrature to Monitor a Drilling Operation	
	<p>Quadrature can be used to track position and vertical drilling speed of the bit in an oil drilling operation. A shaft encoder is rotated by a cable that moves with the drilling shaft. In this application, the same encoder signal is applied to a first Laureate quadrature transmitter for position, and to a second quadrature transmitter for rate. Both transmitters can send a 4-20 mA signal to a control room and be alarmed. In this application, quadrature provides much higher immunity to noise and jitter than a magnetic pickup.</p>

Ordering Guide

Create a model a model number in this format: **LT60QD, CBL04**

Transmitter Type	LT Laureate 4-20 mA & RS485 output transmitter
Main Board	6 Standard Main Board (for position, length or angle) 8 Extended Main Board (for bidirectional rate or position)
Power	0 Isolated 85-264 Vac 1 Isolated 12-32 Vac or 10-48 Vdc
Input Type	QD Quadrature
Accessories	CBL04 RS232 cable, 7ft. Connects RS232 screw terminals of LT transmitter to DB9 port of PC. CBL02 USB to RS232 adapter cable. Combination of CBL02 and CBL04 connects transmitter RS232 terminals to PC USB port.