

Multi-Component Sensor M-2354 with Rated Force / Rated Torque of 10 kN/10 Nm



Performance Features

- Reaction torque/force sensor, non-rotating, for e. g. survey of the bearing friction of ball bearings
- Very short axial length
- Reliable and durable
- Simple handling and assembly
- Special versions on request

Application

- Assembly technology
- Process measuring and control technology
- Automotive industry
- Measuring and control devices
- Tool engineering
- Special mechanical engineering

Dimensions in mm

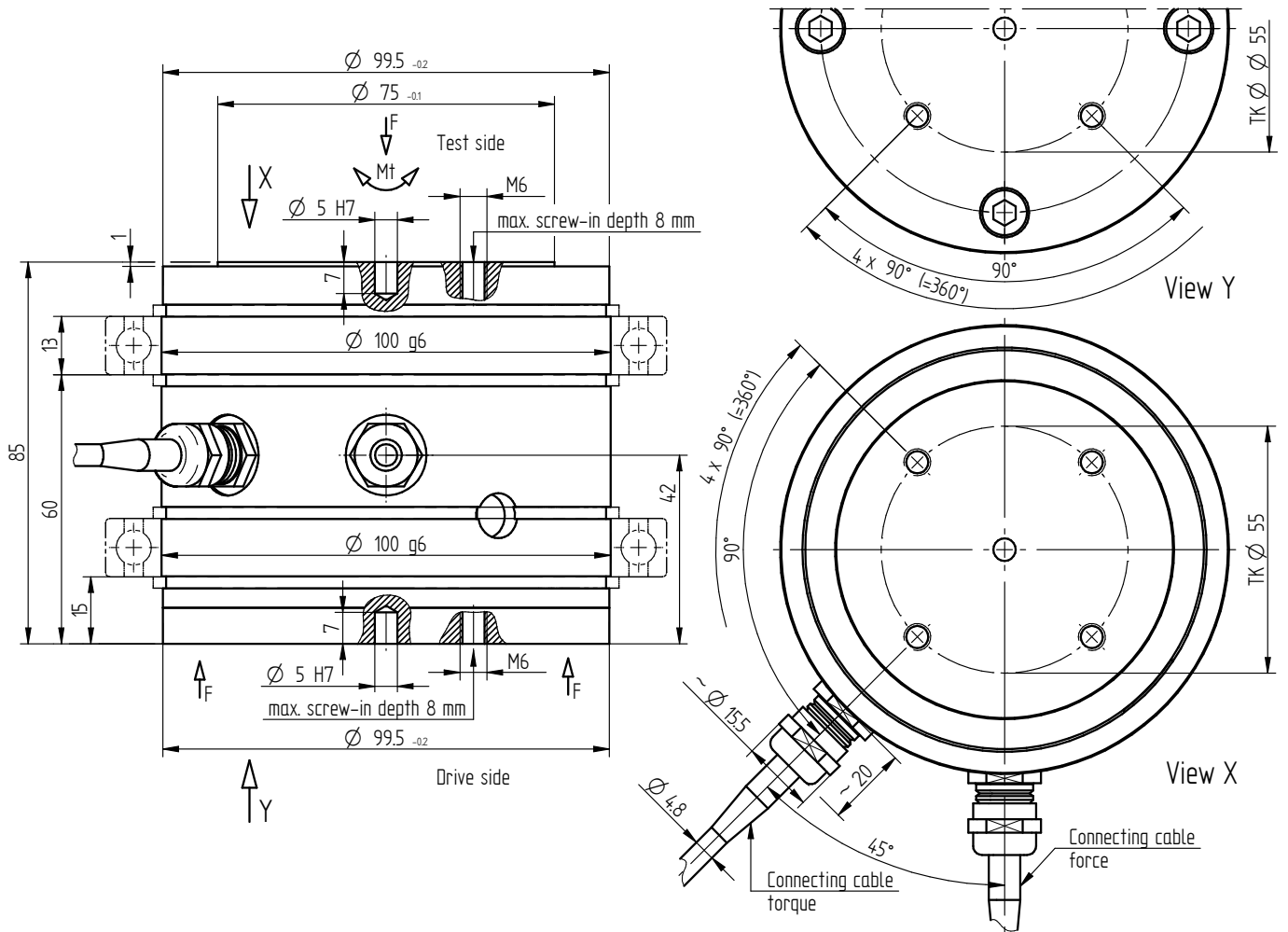

Rated Force/Torque [N/Nm]	Weight [kg]
10/10	3.0

Connection Assignment

Electrical Connection

Excitation (-)	green	●
Excitation (+)	brown	●
Signal (+)	yellow	●
Signal (-)	white	○
Control signal (option)	gray	●
Shield	shield	⊕

Technical Data acc. to VDI/VDE/DKD 2638 and VDI/VDE/DKD 2639

Multi-Component Sensor M-2354

Rated force F_{nom} /Rated torque M_{nom}	kN/Nm	10/10
Accuracy class force	% F_{nom}	0.2
Accuracy class torque	% M_{nom}	0.2
Cross talk	% F/M_{nom}	<1
Relative repeatability error in unchanged mounting position b'	% F/M_{nom}	± 0.1
Rated range of excitation voltage $B_{U, nom}$	VDC	2 ... 12
Bridge resistance R_{Br} (torque)	Ω	350
Input/output resistance R_e/R_a (force)	Ω	350
Rated characteristic value C_{nom}	mV/V	1.0 ± 0.15 %
Insulation resistance R_{IS}	Ω	$>2 \cdot 10^9$
Electrical connection		Cable, 3 m with free strands
Reference temperature T_{ref}	$^{\circ}C$	23
Rated temperature range $B_{T, nom}$	$^{\circ}C$	-10 ... 50
Operating temperature range $B_{T, G}$	$^{\circ}C$	-30 ... 80
Temperature effect on zero signal TK_0	% $F/M_{nom}/10$ K	± 0.2
Temperature effect on characteristic value TK_C	% $F/M_{nom}/10$ K	± 0.2
Operating load (static)	% F/M_{nom}	130
Limit load (static)	% F/M_{nom}	150
Breaking load (static)	% F/M_{nom}	>300
Permissible oscillation stress	% F/M_{nom}	70 (peak-to-peak)
Material		Stainless steel
Level of protection		IP40

Article-No.	Rated Force/Torque [N/ Nm]	Spring Rate [Nm/rad]	Mass Moment of Inertia [kg·m ²]		Lateral Force Limit [kN]
			Drive Side	Test Side	
103943	10/10	2.2E+03	3.0E-03	3.2E-04	2

Options

Article-No.	Description	
100218	Control signal	100 % M_{nom}

Calibrations for Torque

Article-No.	Description	
400676	Linearity diagram in accordance to factory standard	25 % steps
400664	Linearity diagram in accordance to factory standard	10 % steps
400961	Proprietary calibration acc. to VDI/VDE 2646	3 steps
400700	Proprietary calibration acc. to VDI/VDE 2646	5 steps
400688	Proprietary calibration acc. to VDI/VDE 2646	8 steps
	DAkKS-Calibration/Standard on request	

Calibrations for Force

Article-No.	Description	
400628	Linearity diagram in accordance to factory standard	25 % steps
400170	Linearity diagram in accordance to factory standard	10 % steps
400960	Proprietary calibration acc. to DIN EN ISO 376 and DAkkS-DKD-R 3-3	3 steps
400652	Proprietary calibration acc. to DIN EN ISO 376 and DAkkS-DKD-R 3-3	5 steps
400640	Proprietary calibration acc. to DIN EN ISO 376 and DAkkS-DKD-R 3-3	8 steps
	DAkkS-Calibration/Standard on request	

Accessories

Electrical Connection

Article-No.	Description
10323	Cable connector KS6 (6-pin series 581) incl. sensor mounting
10320	Cable connector KSSH15 (15-pin) incl. sensor mounting
43418	Input connector ZA9612FS (ALMEMO) incl. sensor mounting and connector calibration
49205	Input connector ZKD712FS (ALMEMO 202) incl. sensor mounting and connector calibration

Amplifiers

Examples of suitable amplifiers for the multi-component sensor M-2354:

LCV	SI-USB	GM 40	GM 80	GM 80-PA
				