

PROPRIETARY AND CONFIDENTIAL

THE INFORMATION CONTAINED IN THIS DRAWING IS THE SOLE PROPERTY OF DYTRAN INSTRUMENTS INC. ANY REPRODUCTION IN PART OR AS A WHOLE WITHOUT THE WRITTEN PERMISSION OF DYTRAN INSTRUMENTS, INC. IS PROHIBITED

REVISIONS

REV	ECN	DESCRIPTION	BY/DATE	CHK	APPR
-----	-----	-------------	---------	-----	------

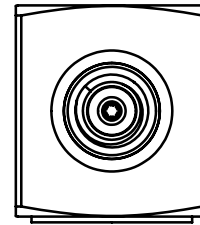
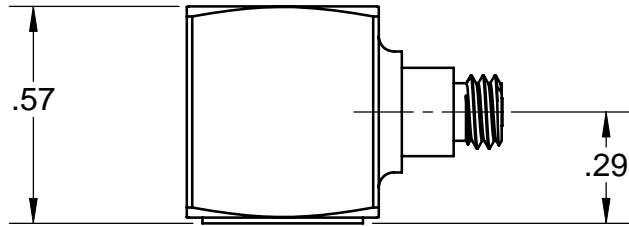
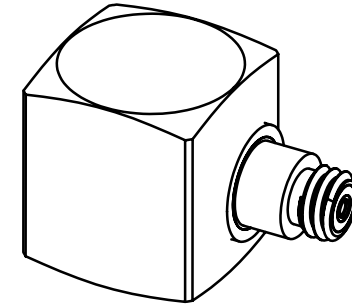
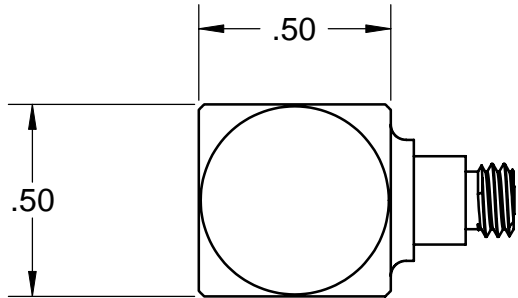

NOTES:

1. MASS: 11 GRAMS NOMINAL

DRILL HOLE SIZE	TOLERANCE	UNLESS OTHERWISE SPECIFIED: INTERPRET DIM & TOL PER ASME Y14.5M - 1994.
.0135 THRU .125	+0.004 / -.001	REMOVE BURRS.
.1260 THRU .250	+0.005 / -.001	COUNTERSINK INTERNAL THDS 90° TO MAJOR DIA.
.2510 THRU .500	+0.006 / -.001	CHAM EXT THDS 45° TO MINOR DIA.
.5010 THRU .750	+0.008 / -.001	THD LENGTHS AND DEPTHS ARE FOR MIN FULL THDS.
.7510 THRU 1.000	+0.010 / -.001	THDS PER MIL-S-7742.
1.001 THRU 2.000	+0.012 / -.001	DIMENSIONS APPLY AFTER FINISHING.

UNLESS OTHERWISE SPECIFIED: DIMENSIONS ARE IN INCHES. TOLERANCES ARE:
DECIMALS ANGLES
.XX ± .010 ± 1°
.XXX ± .005

MATERIAL
Ti 6Al-4V

FINISH
63

ALL MACHINED SURFACES. TOTAL RUNOUT WITHIN .005.
BREAK SHARP EDGES .005 TO .010.
MACHINED FILLET RADII .005 TO .015.
WELDING SYMBOLS PER AWS A2.4.
ABBREVIATIONS PER MIL-STD-12

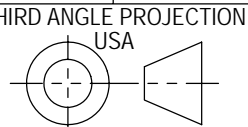

CONTRACT NO.



TITLE:

OUTLINE DRAWING

APPROVALS		DATE
ORIG	PML	6/22/07
CHK		
APP		
APP		

SIZE	CAGE CODE	DWG. NO.	REV
A	2W033	127-3214A	2

SCALE: 2:1	SOLIDWORKS	SHEET 1 OF 1
------------	------------	--------------



**SPECIFICATIONS
MODEL SERIES 3214A IEPE ACCELEROMETERS**

SPECIFICATION	VALUE			UNITS
PHYSICAL				
WEIGHT	11			grams
SIZE, SQUARE x HEIGHT	.50 x 0.57			inches
MOUNTING PROVISION	10-32 X .150 DEEP TAPPED HOLE			
CONNECTOR, SIDE MOUNTED	10-32 Coaxial			
MATERIAL, BASE, CAP & CONNECTOR	TITANIUM			
SEISMIC ELEMENT TYPE	CERAMIC, PLANAR SHEAR			
	MODELS			
	3214A1	3214A2	3214A3	
PERFORMANCE				
SENSITIVITY, ± 5% [1]	10	100	500	mV/g
RANGE F.S. FOR ± 5 VOLTS OUTPUT	± 500	±50	±10	g's
FREQUENCY RANGE, ± 5% (all models)		1 to 10,000		Hz
RESONANT FREQUENCY, NOM. (all models)		35		kHz
EQUIVALENT ELECTRICAL NOISE	.007	.0007	.0002	grms
LINEARITY [2] (all models)		±2		% F.S.
TRANSVERSE SENSITIVITY, MAX. (all models)		5		%
BASE STRAIN SENSITIVITY		0.0028		g's/μσ
	3214A1	3214A2	3214A3	
ENVIRONMENTAL				
MAXIMUM VIBRATION/SHOCK	600/5000	400/5000	200/5000	± gpk
TEMPERATURE RANGE	-60 to +250	-60 to +225	-60 to +180	°F
SEAL, HERMETIC		Glass-to-metal/welded		
COEFFICIENT OF THERMAL SENSITIVITY		.06		%/°F
ELECTRICAL				
SUPPLY CURRENT [3]		2 to 20		mA
COMPLIANCE VOLTAGE RANGE		18 to +30		Volts
OUTPUT IMPEDANCE, TYP.		100		Ω
BIAS VOLTAGE, +10.5 VOLTS NOM.		+11 to +13		VDC
DISCHARGE TIME CONSTANT, NOM.		0.5 – 0.7		Sec
OUTPUT SIGNAL POLARITY		Positive		
FOR ACCELERATION TOWARD TOP				
ELECTRICAL ISOLATION		case grounded		

Accessories supplied: (1) Model 6200 mounting stud.

[1] Measured at 100 Hz, 1 grms per ISA RP 37.2.

[2] Measured using zero-based best straight line method, % of F.S. or any lesser range.

[3] Do not apply power to this device without current limiting, 20 mA MAX. To do so will destroy the integral IC amplifier.