

MV-ID2013M-00C-NNN

1.3 MP Smart Code Reader



Introduction

MV-ID2013M-00C-NNN smart code reader can read different types of 1-dimensional and 2-dimensional codes, and its max. reading speed reaches 45 codes/sec. It adopts deep learning algorithm to process images with good robustness, and can recognize various codes.

Applicable Industry

Consumer electronics, food and beverage, pharmaceutical, semiconductor, new energy, etc.

Available Model

MV-ID2013M-00C-NNN

Dimension

Key Feature

- Compact design and small in size.
- Adopts multiple IO interfaces and plug-in power interface.
- Supports multiple communication protocols, including TCP, Serial, FTP, Profinet, Ethernet/IP, MELSEC/SLMP, etc.
- Mounting holes on panels for flexible mounting from 4 sides.

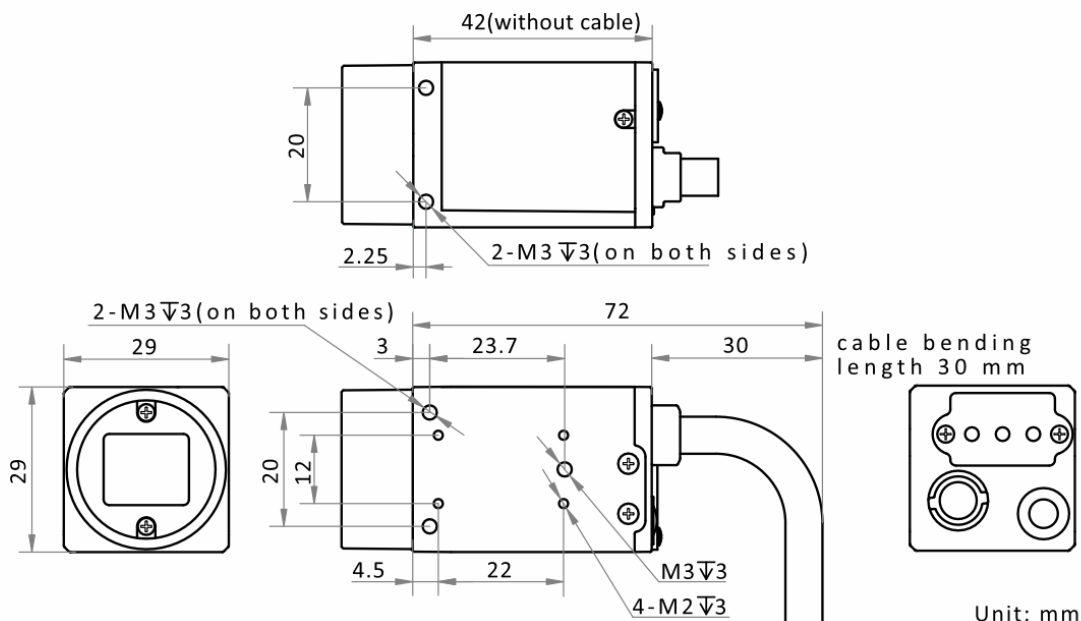

Specification

Model	MV-ID2013M-00C-NNN
Performance	
Symbologies	1-dimensional codes: Code 39, Code 93, Code 128, ITF 14, ITF 25, CodaBar, EAN 8, EAN 13, UPCA, UPCE
	2-dimensional codes: QR Code, Data Matrix
Max. frame rate	60 fps
Max. reading speed	45 codes/sec
Sensor type	CMOS, global shutter
Pixel size	4 μm × 4 μm
Sensor size	1/2.7"
Resolution	1280 × 1024
Exposure time	40 μs to 1 sec
Gain	0 dB to 15 dB
Mono/color	Mono
Communication protocol	SmartSDK, TCP Client, Serial, FTP, HTTP, TCP Server, Profinet, MELSEC/SLMP, Ethernet/IP, ModBus, UDP, Fins
Electrical feature	
Data interface	Fast Ethernet
Digital I/O	17-pin M12 connector provides power and I/O, including none-isolated input × 1 (Line 2), none-isolated output × 1 (Line 3), configurable bi-directional none-isolated I/O × 2 (Line 0/1), RS-232 × 1. Device trigger via pressing button supported.
Power supply	12 VDC to 24 VDC
Max. power consumption	Approx. 6 W@12 VDC
Mechanical	
Lens mount	C-mount
Indicator	Power indicator (PWR), network indicator (LNK), and status indicator (STS).
Dimension	29 mm × 29 mm × 42 mm (1.1" × 1.1" × 1.2")
Weight	Approx. 140 g (0.3 lb.)
Ingress protection	IP40
Temperature	Working temperature: 0 °C to 50 °C (32 °F to 122 °F) storage temperature: -30 °C to 70 °C (-22 °F to 158 °F)
Humidity	20% to 95% RH, non-condensing
General	
Client software	IDMVS
Certification	CE, FCC, RoHS