

LOW CAPACITY SINGLE POINT LOAD CELLS

LSP SERIES BEAM LOAD CELL

CAPACITY RANGES:

1, 2, 5, 10 Kg.

The LSP Series is a low capacity, low cost, high accurate single point load cell. It is ideal for OEM applications such as electronic scales and weighing machines. The single point design is highly resistant to eccentric loading allowing direct mounting to the scale base and weighing platform. The LSP Series features a moisture proof sealant.



Wiring Color Code

+Exc. Red -Exc. Black
+Sig. Green -Sig. White

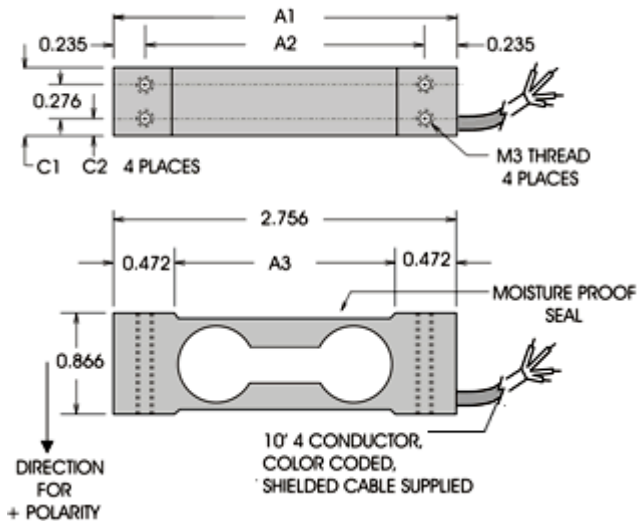

SPECIFICATIONS

Rated Output (R.O.)
Range 1Kg: 1.0 mV/V nominal
Rated Output (R.O.)
Ranges 2,5, and 10Kg: 1.5 mV/V nominal
Nonlinearity: 0.02% of R.O.
Hysteresis: 0.02% of R.O.
Nonrepeatability: 0.02% of R.O.
Zero Balance: $\pm 5\%$ of R.O.
Compensated Temp.
Range: 14° to 104°F
Safe Temp. Range: 14°F to 140°F
Temp. Effect on Output: 0.0022 of Load/°F
Temp. Effect on Zero: 0.0022% of R.O./°F
Terminal Resistance: 350 ohms nominal
Excitation Voltage: 10 VDC (15 VDC max)
Safe Overload: 150% of R.O.
Max. Weighing
Platform Size: 7.87" x 7.87"