

Hollow-Shaft Conductive Plastic Potentiometric Sensors

GL Series

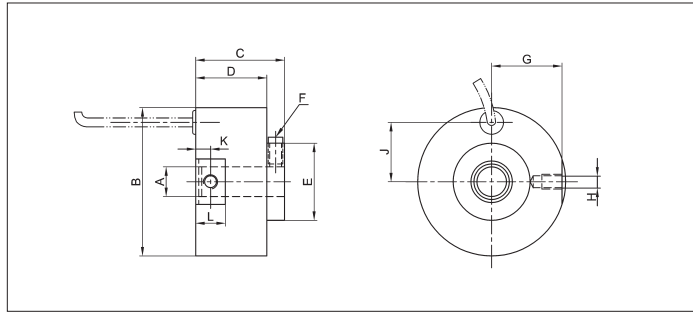
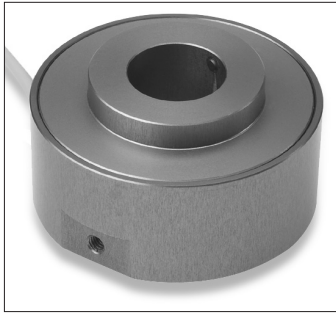

Special features

- hollow shaft
- drill hole \varnothing 6 - 30 mm
- 10×10^6 movements
- excellent linearity
- very high resolution – better than 0.1°

Novotechnik hollow-shaft precision potentiometer angle sensors are designed for easy installation.

Careful selection of materials and high-quality components ensure a constant and accurate angle measurement throughout the entire service life of the sensor.

Special designs with custom shaft dimensions and angular ranges are available on request.

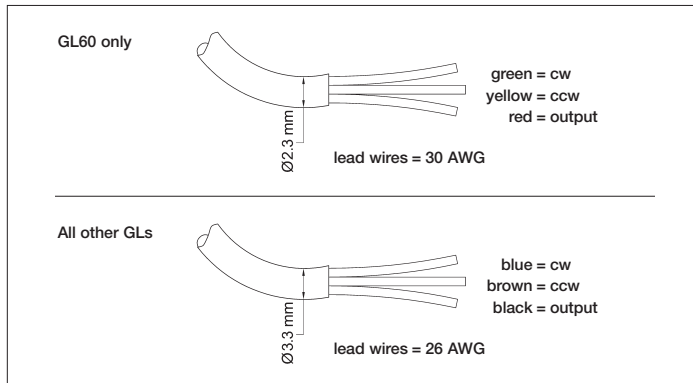

Description	
Dimensions	see drawing
Case	anodized aluminum
Drill hole	6; 10; 20; 30; mm/ISO H9
Bearings	slotted ball bearing
Resistance element	conductive plastic
Wiper assembly	precious metal multi-finger wiper
Electrical connections	cable 1 m PUR

Recommended accessories

MAP process-control indicators and display. MUP signal conditioner for standardized output signals.

Important

All values given for this series – including linearity, lifetime, micro-linearity, resistance to external disturbances and temperature coefficient in voltage dividing mode – are quoted for the device operating with the wiper voltage driving an operational amplifier working as a voltage follower where virtually no load is applied to the wiper ($I_e \leq 1 \mu A$).

Type designations	GL60	GL100	GL200	GL300			
Mechanical Data							
Dimensions	see drawing						
A	6	10	20	30	mm		
B	31	50	60	74	mm		
C	17.5	30	31	32	mm		
D	13	24	25	26	mm		
E	18	26	36	46	mm		
F	M3	M4	M4	M4			
G	14.7	23.8	28.8	35.8	mm		
H	M3	M4	M4	M4			
J	11.2	20	25	31	mm		
K	2.5	5	5	5	mm		
L	5	10	10	10	mm		
Mounting	1 socket screw						
Mechanical travel	continuous	348	346	348	°		
Cable	3x0.07	3x0.14	3x0.14	3x0.14	mm ²		
Permitted shaft loading (axial and radial) static or dynamic force	10				N		
Torque	≤ 0.5	≤ 1.5	≤ 6.0	≤ 6.0	Ncm		
Maximum operational speed	230	200	165	130	RPM		
Weight	32	120	178	260	g		
Electrical Data							
Actual electrical travel	150; 354	140; 340	150; 340	340	(±2°)		
Available resistance values	5; 10	5; 10	5; 10	20	kΩ		
Resistance tolerance	±20				%		
Repeatability	0.07; 0.03 (=0.1°)	0.07; 0.03 (=0.1°)	0.07; 0.03 (=0.1°)	0.03 (=0.1°)	%		
Effective temperature coefficient of the output-to-applied voltage ratio	5 (typical)				ppm/K		
Independent linearity	±0.25				%		
Max. permissible applied voltage	42				V		
Recommended operating wiper current	≤ 1				μA		
Max. wiper current in case of malfunction	10				mA		
Insulation resistance (500 VDC, 1 bar, 2 s)	≥ 10,000				MΩ		
Dielectric strength (AC, 50 Hz, 1 min, 1 bar)	1,000				V		
Environmental Data							
Temperature range	-25...+75				°C		
Vibration	30...500 A _{max} = 0.75 a _{max} = 10				Hz mm g		
Life	10 million				movements		
Shock (DIN IEC 68 T2-27)	50 7				g ms		
Protection class (DIN 40050)	IP 63						
Order designations							
Type	Art. no.	R in kΩ	electr. angle in °	Type	Art. no.	R in kΩ	electr. angle in °
GL60 5K0 M150	82347	5	150	GL60 10K0 M354	70011	10	354
GL100 5K0 M150	82026	5	150	GL100 10K0 M340	82027	10	340
GL200 5K0 M150	82028	5	150	GL200 10K0 M340	82029	10	340
				GL300 20K0 M340	82031	20	340