

Ethernet system for length measurement, 24-bit 16 inductive transducers, LVDT, half-bridge



MSX-E3701-DIO

Acquisition of 16 inductive transducers

For half-bridge and LVDT transducers

24 V digital trigger input

32 digital I/O, 24 V



Integrated Ethernet switch



*Operating temperature



ARM⁹ Technology

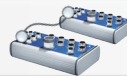

Cascadable, can be synchronised in the μ s range

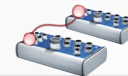

Timer function for synchro trigger signal



on request



DatabaseConnect see page 114



More information on www.addi-data.com

Features

- ARM⁹ 32-bit processor
- Robust standardized metal housing
- Power Save Mode: Reduced power consumption when no acquisition runs

Inputs for transducers

- 16 inputs for transducers, 24-bit, 5-pin M18 female connector
- Half-bridge (HB), LVDT
- Diagnostics at short-circuits or line break
- 16-bit accuracy

Transducer precision: example of a measurement

Typ TESA GT21, range ± 2 mm ($\Delta 4$ mm), 16-bit accuracy

$$\frac{4 \text{ mm}}{2^{16}} = \pm 61 \text{ nm} = 0,061 \mu\text{m}$$

Digital I/O

- 16 inputs for transducers, 24-bit, 5-pin M18 female connector
- 32 digital I/O, 24 V:
16 opt. isolated inputs, 24 V, optional filter
16 opt. isolated outputs, 11 V to 36 V, output current per channel 150 mA

Safety features

- Status LEDs for fast error diagnostics
- Optical isolation • Input filters
- Overvoltage protection ± 40 V
- Internal temperature monitoring

Interfaces

- Fast 24 V trigger input
- Ethernet switch with 2 ports
- Synchronisation/trigger In/Out
- Line in for 24 V supply and cascading

Communication interfaces

- Web server (configuration and monitoring)
- Command server SOAP for transferring commands
- Data server (TCP/IP or UDP socket) for sending acquisition data
- Event server (TCP/IP socket) for sending system events (Diagnostics such as temperature, short-circuits ...)
- Command server Modbus TCP and Modbus (UDP) for sending commands

* Preliminary Product information

Synchronisation/time stamp

Time stamp

Several MSX-E systems can be synchronised with one another in the μ s range through a synchro connection. This allows to start a synchronous data acquisition, to generate trigger events and to synchronise the time on several MSX-E systems. Furthermore, the systems have a time stamp that logs the point in time at which the data was acquired by the system.

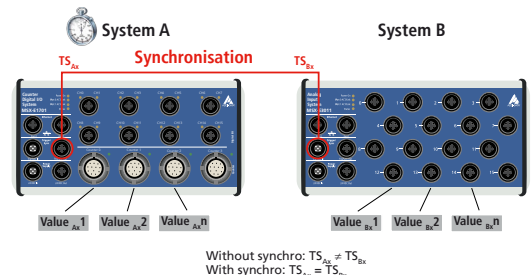

The combination of synchronisation and time stamp (TS) allows the clear allocation of signals that were captured by several systems.

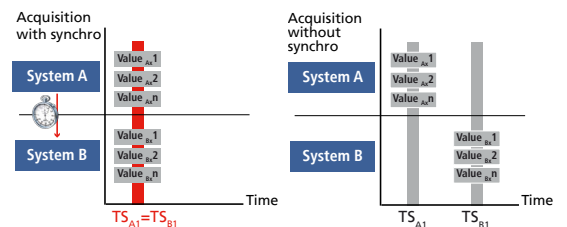



Acquisition modes

Auto-refresh mode

In the auto-refresh mode, the measurement values are updated automatically after each acquisition. The acquisition is initialised once and the values of the channels are stored in the memory of the MSX-E Ethernet system. The client (e.g. PC, server, PLC, ...) reads the acquired values asynchronously to the acquisition through socket connection, SOAP or Modbus function. Thereby, the new value is read and the old values are overwritten. In addition to the measurement values, the auto-refresh counter can also be read, which allows to sort the measurement values chronologically. The auto-refresh mode can be combined with a hardware or a synchro trigger and also allows the automatic averaging of values.

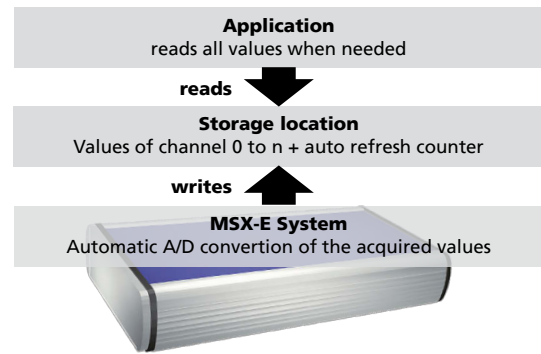

Sequence Mode

In the sequence mode, a list of channels is acquired. Thereby, the single measurement rows are stored one after another. The client receives the acquired values asynchronously to the acquisition through a socket connection. In the sequence mode, the measurement values are read in chronological order, this means the oldest values are read first. The acquisition can be effected continuously, with or without delay or in combination with a hardware or synchro trigger.

Example: Sequence acquisition of 6 channels, 1 trigger per sequence
Send data after 2 sequences – 1000 sequences in total

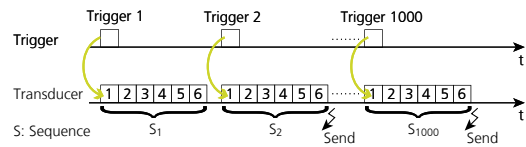

Digital I/O

In addition to the transducer channels, the MSX-3701-DIO system has 32 digital 24 V I/O channels (16 inputs, 16 outputs). The system is therefore very flexible and can manage complete measurement and test applications. Example: Test bench for cylindrical parts, probing the workpieces, automatic regulation of the transducers and visualisation of the results via LED traffic light. The measurement data is at the same time stored in a database.

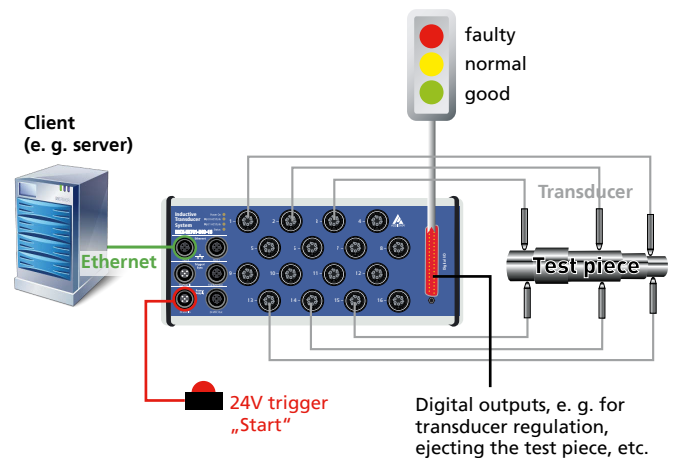

Onboard programming / stand-alone operation

Development mode

With the Development mode of the MSX-E systems you can customise your measurement, control and regulation applications to fit your requirements. The programs run directly on the MSX-E systems, which has two advantages: external PCs are relieved and you can process data freely according to your requirements. This helps you to improve the efficiency of your processes and to secure your investments.

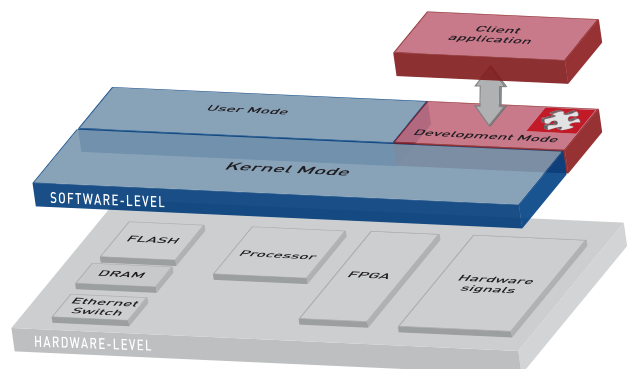

* Preliminary product information

ConfigTools

The **ConfigTools** program allows an easy administration of the MSX-E systems. These are automatically detected in the network. **ConfigTools** consists of common and specific functions. In addition, with **ConfigTools**, the complete configuration of a MSX-E system can be saved and transferred to another system of the same type (clone function).

ConfigTools is included in the delivery.

ConfigTools functions for MSX-E3701-DIO:

- Change of IP address
- Display of web interface
- Firmware update
- Save/load system configuration
- Save/load channel configuration
- Transducer calibration
- Transducer database
- Transducer monitoring
- Transducer diagnostics

Very easy use through the „ConfigTools“ program; The MSX-E system is automatically detected in the network.

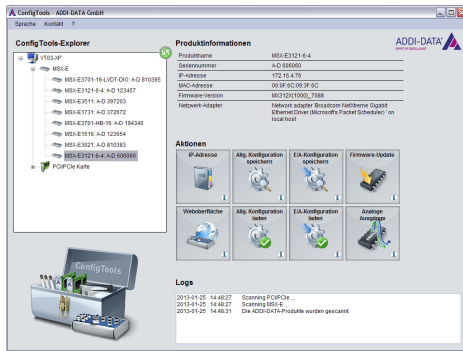

... and can then be calibrated.

Features

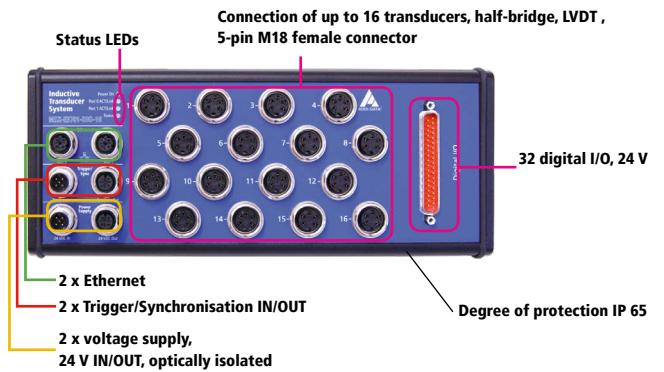

Simplified block diagram

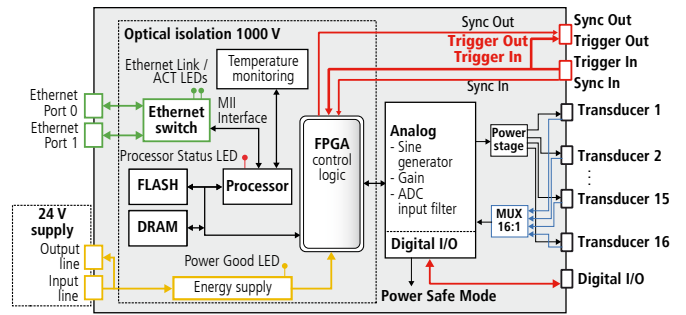

Cascading

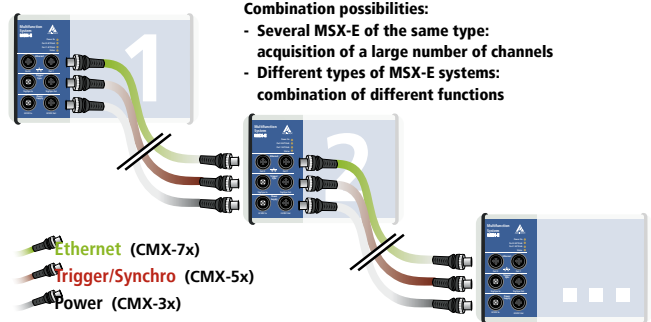

ADDI-DATA connection technology

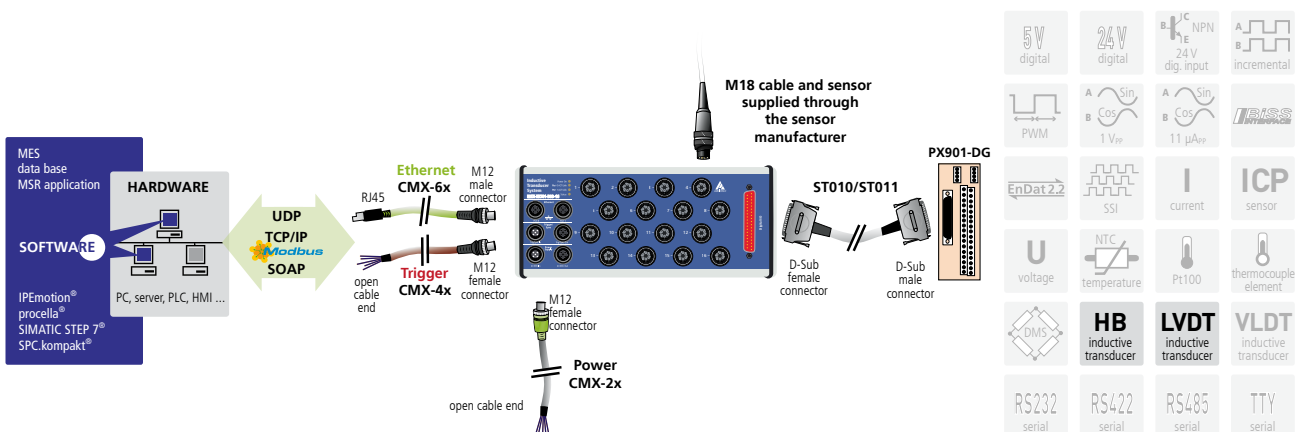

* Preliminary product information



Specifications*

Inputs for inductive transducers

Channel features	
Number:	16 multiplexed
Input type:	Single-Ended
Coupling:	DC
Resolution:	24-bit
Sampling frequency f_s :	on 1 channel at primary frequency f_p of
	5 kHz
	7.69 kHz
	10 kHz
	12.5 kHz
	20 kHz
	50 kHz
	From $n \geq 2$ channels $f_s = \frac{f_p}{SP \times n}$
	$f_p =$ primary frequency
	SP = settling period ($5 \leq SP \leq 255$)
	f_s concerns here all n channels

Example with TESA GT21:	On one channel $f_s = f_p = 12.5$ kHz
	From $n \geq 2$ channels $f_s = \frac{12.5 \text{ kHz}}{5 \times 4} = 625$ Hz for 4 channels
	$f_s = \frac{12.5 \text{ kHz}}{5 \times 8} = 312.5$ Hz for 8 channels
	$f_s = \frac{12.5 \text{ kHz}}{5 \times 16} = 156.25$ Hz for 16 channels

Input level	
Input impedance:	2 k Ω software-configurable 10 k Ω , 100 k Ω , 10 M Ω

Sensor supply (sine generator)	
Type:	Differential sine (180° phase shift)
Coupling:	AC
Programmed signals:	5 kHz; 7.69 kHz; 10 kHz; 12.5 kHz; 20 kHz, 50 kHz,
Output frequency f_p :	depending on the transducer
Output impedance:	< 0,1 Ω typ.
	> 30 k Ω typ. in shutdown mode
Short-circuit current:	0.7 A typ. at 25°C with thermal protection

Power Supply

Nominal voltage:	24 V	===
Voltage supply:	18-30 V	
Optical isolation:	1000 V	
Current consumption at 24 V:	90 mA	typ. in power safe mode / idle
	120 mA	Power on
	150 mA	DAC init, sinus on, buffer off
	200 mA	typ. without load (transducer) at ± 9 V power (buffer on)
	320 mA	typ. with 16 Solartron AX15 transducers at ± 7 V power, 5 kHz and 3 V _{rms}

Reverse voltage protection

Digital inputs

Number of inputs:	16, common ground acc. to IEC 1131-2
Optical isolation:	1000 V through opto-couplers
Nominal voltage:	24 VDC
Input voltage:	0 to 30 V
Logic input levels:	UH (max) 30 V typ. UH (min) 19 V typ. UL (max) 14 V typ. UL (min) 0 V typ.

Digital outputs

Number of outputs:	16
Optical isolation:	1000 V through opto-couplers
Output type:	High-side, load to ground acc. to IEC 1131-2
Nominal voltage:	24 V

Voltage supply:	11 V-36 V
Output current per channel:	150 mA max.
Diagnostics:	Common diagnostics bit for all 16 channels at overtemperature of one channel

Ethernet

Number of ports:	2
Cable length:	150 m max. at CAT5E UTP
Bandwidth:	10 Mbps auto-negotiation 100 Mbps auto-negotiation
Protocol:	10Base-T IEEE802.3 compliant 100Base-TX IEEE802.3 compliant
Optical isolation:	1000 V
MAC address:	00:0F:6C:##:##:##, unique for each device

Trigger

Number of inputs:	1 trigger input
Number of outputs:	1 trigger output
Filters/protective circuit:	Low-pass/transorb diode
Optical isolation:	1000 V
Nominal voltage:	24 V external
Input voltage:	0 to 30 V
Input current:	11 mA at 24 VDC, typical
Input frequency (max.):	2 MHz at 24 V

Connector, common with Synchro

Trigger input:	1 x 5-pin male connector M12
Trigger output:	1 x 5-pin female connector M12

Synchro

Number of inputs:	1
Number of outputs:	1
Max. cable length:	20 m
Optical isolation:	1000 V
Signal type:	RS485

Connector, common with Trigger

Trigger input:	1 x 5-pin male connector M12
Trigger output:	1 x 5-pin female connector M12

EMC – Electromagnetic compatibility

The product complies with the European EMC directive. The tests were carried out by a certified EMC laboratory in accordance with the norm from the EN 61326 series (IEC 61326). The limit values as set out by the European EMC directive for an industrial environment are complied with. The respective EMC test report is available on request.

System features

Interface:	Ethernet acc. to specification IEEE802.3
Dimensions:	260 x 110 x 50 mm
Weight:	965 g
Degree of protection:	IP 65
Operating temperature:	-40 °C to + 85°C

Interface connectors

Ethernet:	2 x 4-pin female connector, D-coded M12 for port 0 and port1
Trigger/Synchro input:	1 x 5-pin M12 male connector
Trigger/Synchro output:	1 x 5-pin M12 female connector
Voltage supply	
24 VDC input:	1 x 5-pin M12 male connector
24 VDC output:	1 x 5-pin M12 female connector

Ordering information

MSX-E3701-DIO

Ethernet system for length measurement, 24-bit, 16 inductive transducers, LVDT, half-bridge. Incl. technical description, software drivers and ConfigTools.

Versions

MSX-E3701-DIO-HB-16: for 16 HB inductive transducers

MSX-E3701-DIO-LVDT-16: for 16 LVDT inductive transducers

Connection cables for 32 dig. I/O, 24 V auf 37-pol. D-Sub-Connector

ST010: Standard round cable, shielded twisted pairs, 2m

PX901-DG: Screw terminal board with Schraubklemmen, LED Status display, for DIN rail

Voltage supply

CMX-2x: Shielded cable, M12 5-pin female connector/open end, IP 65

CMX-3x: For cascading, shielded cable, M12 5-pin female connector/male connector IP 65

Trigger/Synchro

CMX-4x: Shielded cable, M12 5-pin female connector/open end, IP 65

CMX-5x: For cascading, shielded cable, M12 5-pin female connector/male connector IP 65

Ethernet

CMX-6x: CAT5E cable, M12 D-coded male connector/RJ45 connector

CMX-7x: For cascading, CAT5E cable, 2 x M12 D-coded male connector

Options

MX-Clip, MX-Rail (please specify when ordering!),

MX-Screw, PCMX-1x

* Preliminary product information