

# Digital I/O board, 16 isolated channels, 24 V



## PA 1508

8 digital inputs, 24 V

Optical isolation between all input channels

8 digital outputs, 24 V, 500 mA/channel

Optical isolation 1000 V

Overvoltage protection

2 diagnostic outputs, progr. watchdog



LabVIEW™



LabWindows/CVI™

### Features

#### 8 digital inputs, 24 V, isolated

- 2 connection lines per input
- Parallel acquisition of digital 24 V signals
- Each input channel has its own ground line

#### 8 digital outputs, 24 V, isolated

- Each output channel can be triggered independently from the others
- The output channels are current-limited and suitable for loads with high inductive currents
- 2 diagnostic outputs generate LOW level at overtemperature
- Watchdog: can be activated through software, readable
- After power-on the outputs are reset to "0"
- Addressing through DIP switches

#### Safety features

- Optical isolation 1000 V
- Voltage supervision
- Creeping distance IEC 61010-1 (VDE411-1)
- Safety for the inputs: voltage reversal protection, LC filters
- Safety for the outputs:
  - Overtemperature protection: Shut-down logic at approx. 125-140 °C
  - Short-circuit current at 1.5 A
  - Shut-down logic, when the external supply voltage drops below 5 V.
- Safety features for the ext. supply voltage:
  - Overload protection: self-resetting fuse (electronic fuse),
  - Overvoltage protection through varistors and transorb diodes
  - screened through LC filters

#### Protective circuitry for the input channels

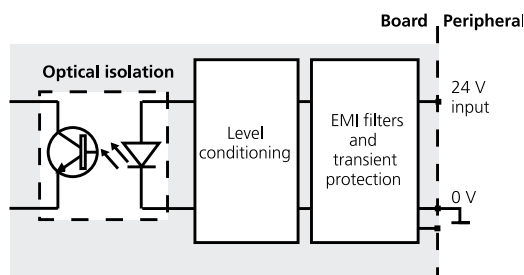

#### EMC tested acc. to 89/336/EEC

- IEC 61326: electrical equipment for measurement, control and laboratory use

#### Applications

- Industrial I/O control
- Automatic test equipment
- Interface to electromechanical relays
- Monitoring of 24 V signals
- Activation of alarm
- Signal switching
- ON/OFF monitoring of motors, lights...
- Machine interface
- ...

#### Software drivers

A CD-ROM with the following software and programming examples is supplied with the board.

#### Standard drivers for:

- Windows 2000/NT/98/95, Windows 3.11, MS-DOS

#### Drivers for the following application software:

- LabVIEW 5.01

#### Samples for the following compilers:

- Microsoft VC++ 5.0
- Microsoft C 6.0
- Borland C++ 5.01
- Borland C 3.1
- Visual Basic 5.0
- Delphi 4
- Turbo Pascal 7.0

#### On request:

- LabWindows/CVI 5.01

Current driver list on the web: [www.addi-data.com](http://www.addi-data.com)

#### Protective circuitry for the output channels

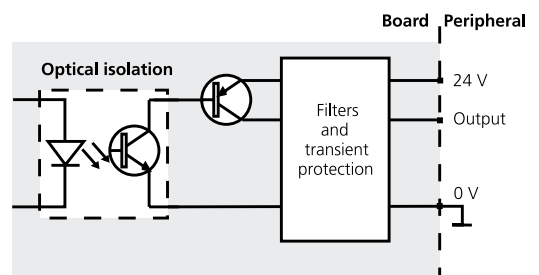

# Digital I/O board, 16 isolated channels, 24 V

PA 1508

## Specifications

### Digital inputs

Number of inputs:	8 (separate grounds)
Optical isolation:	through optical couplers, 1000 V from the PC to the peripheral
Optical isolation:	Input channels separated from the others
Nominal voltage:	24 V
Inputs current at 24 V:	6 mA typ.
Logic input level:	U nominal: 24 V UH max.: 30 V UH min.: 19 V UL max.: 14 V UL min.: 0 V
Signal delay:	70 µs (at 24 V)
Maximum input frequency:	5 kHz (at 24 V)

### Digital outputs

Outputs:	8
Optical isolation:	through optical couplers, 1000 V
Output type:	High-side (Load at ground) acc. to IEC 1131-2
Nominal voltage:	24 V
Supply voltage:	10 to 36 V, min. 5 V (through front connector)
Max. current for 8 outputs:	3 A typ.
Output current/channel:	500 mA typ./channel
Output current for 8 channels:	350 mA typ./channel
Short-circuit current/ Shut-down at 24 V, Rload < 0.1Ω:	1.5 A
RDS ON resistance:	0.4 Ω max.
Switch-on time:	I out=0.5 A, Load = resistance: 120 µs
Switch-off time:	I out=0.5 A, Load = resistance: 40 µs
Overtemperature (Shut-Down):	170 °C (Output driver)
Temperature hysteresis:	20 °C (Output driver)

### Safety

Shut-down logic:	When the ext. 24 V voltage drops below 5 V, the outputs are switched off. Diagnostic: status-bit or interrupt to PC
Watchdog time:	4.6 s
Diagnostic outputs:	1 for each group of 4 channels

### EMC – Electromagnetic compatibility

The product complies with the European EMC directive. The tests were carried out by a certified EMC laboratory in accordance with the norm from the EN 61326 series (IEC 61326). The limit values as set out by the European EMC directive for an industrial environment are complied with. The respective EMC test report is available on request.

### Physical and environmental conditions

Dimensions:	125 x 91 mm
System bus:	ISA
Place required:	Short board, 1 AT or XT slot
Operating voltage:	+5 V, ± 5 % from PC
Current consumption:	30 mA typ.
Front connector:	37-pin SUB-D male connector
Temperature range:	0 to 60 °C (with forced cooling)

### PX 9100

Screw terminals:	37 for connecting the peripheral
Conductor cross section:	2.5 mm <sup>2</sup>
Status display:	16 LEDs for status display, 1 green LED for the voltage supply 2 red diagnostic LEDs for error status of the power drivers.
Connector:	37-pin SUB-D female connector
Dimensions:	(L x W x H) 118 x 84 x 66 mm
Temperature range :	0 to 60 °C

## Simplified block diagram

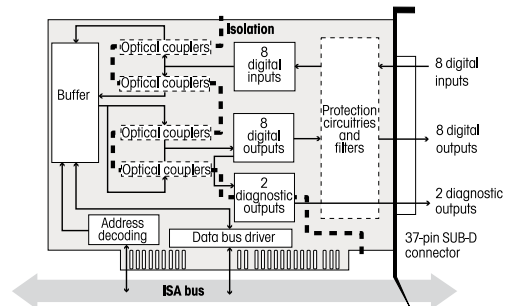

## Pin assignment – 37-pin SUB-D male connector

Reserve	37	GND input 8
Dig. input 8	36	GND input 7
Dig. input 7	35	GND input 6
Dig. input 6	34	GND input 5
Dig. input 5	33	GND input 4
Dig. input 4	32	GND input 3
Dig. input 3	31	GND input 2
Dig. input 2	30	GND input 1
Dig. input 1	29	0 V ext.
0 V ext.	28	24 V ext.
24 V ext.	27	24 V ext.
Dig. output 8	26	24 V ext.
Dig. output 7	25	Diagnostic 2
Dig. output 6	24	Dig. output 5
Dig. output 5	23	ext. V filter
Dig. output 4	22	GND output
Dig. output 3	21	Diagnostic 1
Dig. output 2	20	Dig. output 1
Dig. output 1	1	

## ADDI-DATA connection

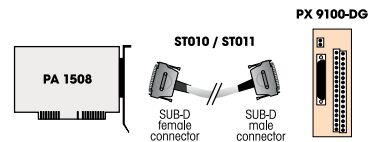

Terminal panel PX 9100  
with cable ST010



## Ordering information

### PA 1508

Digital I/O board, 16 isolated channels, 24 V. Incl. technical description and software drivers.

### PX 9100

Screw terminal panel, LED status display, incl. technical description.

### Connection

**PX 9100-DG:** Screw terminal panel for DIN rail, LED status display

**ST010:** Standard round cable, shielded, twisted pairs, 2 m

**ST011:**

Standard round cable, shielded, twisted pairs, 5 m

**ST010-S:**

Same as ST010, for high currents (24V supply separated)