

# Measuring Amplifier for Strain Gage Sensors

## MODEL 9236



### Highlights

- Operates with up to 4 measuring channels
- Voltage output 0 to  $\pm 5$  V / 0 to  $\pm 10$  V
- Protected against reverse connection and short-circuit
- Also available as circuit board without housing
- Simple configuration using DIP switch
- High degree of protection up to IP67

### Options

- Inline version with PG screw connection (Standard)
- Inline version with M12 5-pin connector on the output side
- Circuit board version
- Hat rail version in multi-channel housing with 2, 3 or 4 measuring channels

### Applications

- Automatic production machinery
- Laboratory measurements
- Integration into customer's circuit boards
- Field measurements

### Product description

The input range of the cost-effective amplifier is appropriate for sensitivities between 0.5 and 30 mV/V and is also suitable for semiconductor strain gage. The measuring amplifier itself is powered by voltages between 15 V and 30 V. Internally, the highly accurate, short-circuit protected sensor excitation voltage is generated and used to supply the sensor's measuring bridge.

The analog output voltage can be set to a range from 0 to  $\pm 5$  V or 0 to  $\pm 10$  V. Alternatively, customer-specific settings are possible. DIP switches are used to set the input range. Fine adjustments and zero point setting are performed by means of multi-turn potentiometers that are mounted on the circuit board. The sensors are connected, and the auxiliary power supplied, through user-friendly screw terminals.

The amplifier in the IP67 version can, if in fact necessary, be achieved by clamping, gluing, or with the aid of a cable tie. The open circuit board has mounting holes for easy assembly. The amplifier's limit frequency is 1 kHz.

Various housing variants are available. For field use, the IP67 variant with PG screw connection or, alternatively, with an M12 connector on the output side is available. The pluggable version allows for quick and easy installation and removal. Since the sensor is permanently connected to the measuring amplifier, the measuring chain can be installed as a whole. For mounting the measuring amplifier in the control cabinet, we recommend the 2-channel, 3-channel, or 4-channel DIN rail version. For use in the laboratory or as an OEM product, the pure circuit board version can be selected.

### NEW

Pluggable variant on the output side via M12 5-pin connector



IP67 version with M12 connector

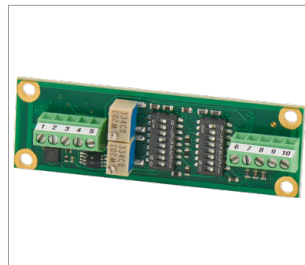

Circuit board version

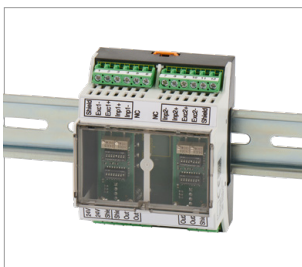

2-channel hat rail version

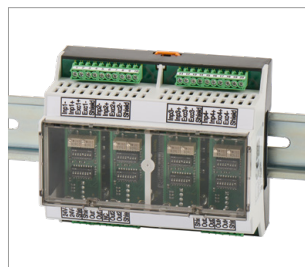

4-channel hat rail version

## Technical Data

Connectable sensors		
<b>Strain gages</b>		
Bridge resistance		350 Ω ... 5 kΩ
Connection technology		4 wire
Excitation		2.5 V
Excitation current		10 mA
Power consumption		approx. 0.3 VA
Configurable characteristic		0.5 mV/V ... 30 mV/V
Default setting		1.5 mV/V
<b>Analog output</b>		
Output voltage selectable		0 ... ±5 V / 0 ... ±10 V (Standard) umschaltbar
Output resistance		440 Ω
<b>General amplifier data</b>		
Measurement error		0.1 % F.S.
Zero point shift		25% or 5% (default) of the measuring range, switchable
Temperature coefficient		< 100 ppm/K
Zero drift		< 0.4 μV/K
Auxiliary power		15 ... 30 VDC
Current consumption		20 mA / 1-Kanal
Cut-off frequency		1 kHz
Range of operating temperature		0 ... +60 °C
Humidity		10 ... 80 %, no condensation
<b>Housing IP67</b>		
Kind of housing		tube housing
Connection		via PG7 at screw terminal, optionally on the output side with M12 5-pin connector, A-coded
Dimensions (L x B):	[mm]	120 x 25
Material		Aluminium
Protection class		IP67
Weight	[g]	150
<b>Housing IP20 / 2-4 channels</b>		
Kind of housing		mounting rail housing
Connection		at screw terminal
Dimensions (L x B x T)	[mm]	3-4 channels 108 x 90 x 63 2 channels 72 x 90 x 63
Material		Plastic
Protection class		IP20
Weight	[g]	150
<b>Open circuit board</b>		
Connection		on screw terminal
Dimensions (L x B)	[mm]	59 x 19
Mounting	[mm]	4 holes for screws 2.5 in grid 14.6 x 53.6
Weight	[g]	50

## Terminal assignment

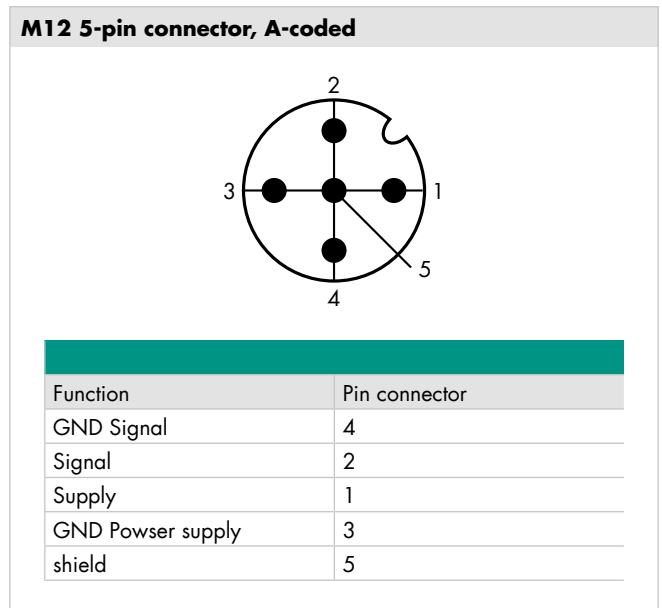
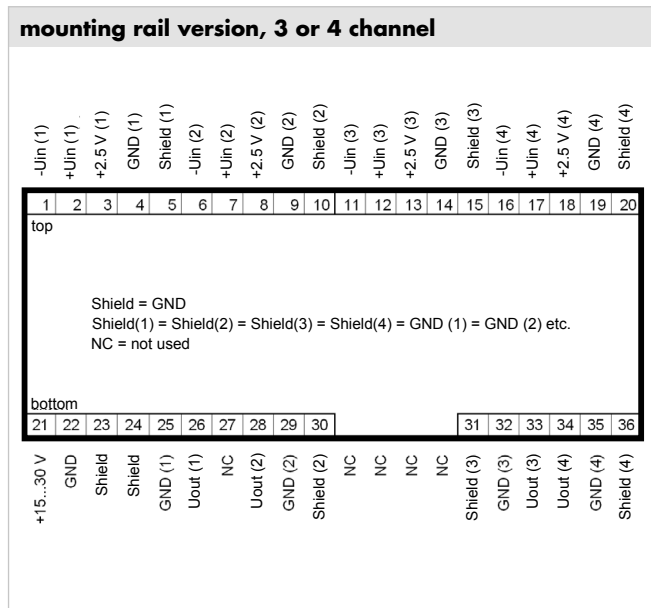
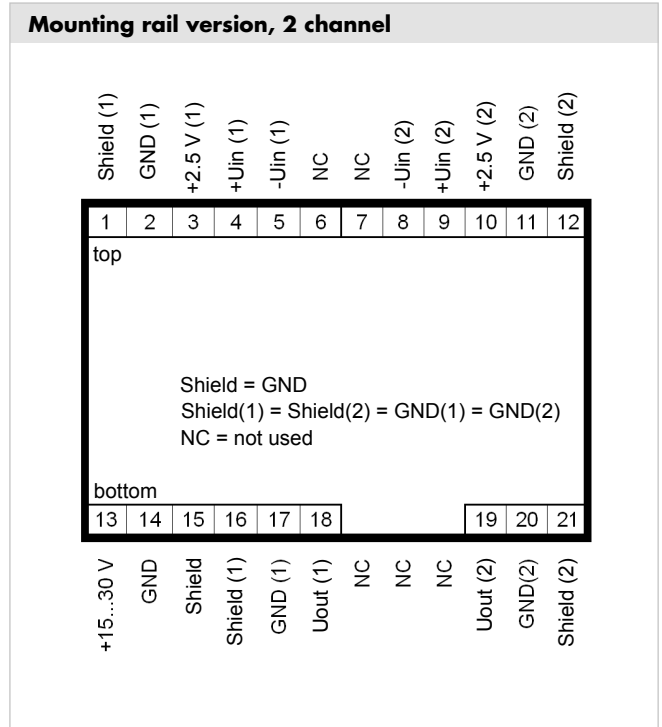
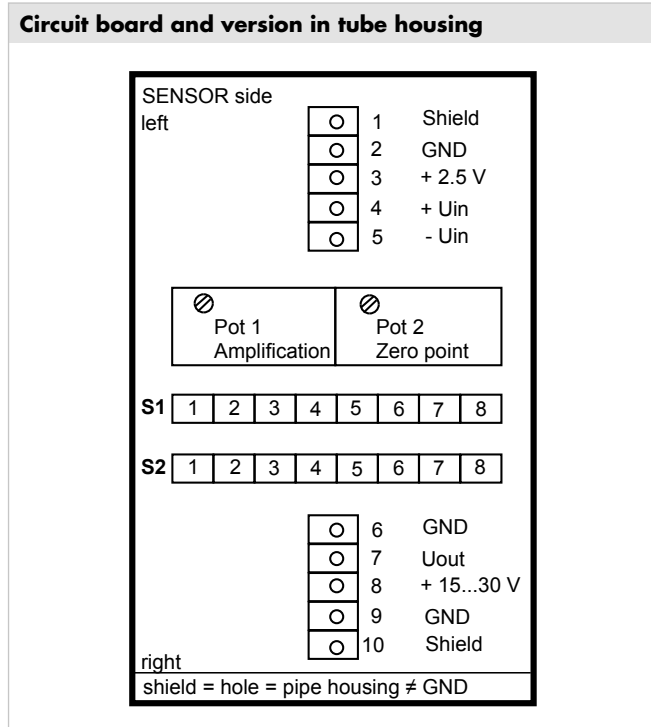

## Accessories

Order Code	
9900-K303	Connection cable with 4-pin M12 x 1 coupling socket, 3 m, open cable ends
9900-K304	Connection cable with 4-pin M12 x 1 coupling socket, 1.5 m, open cable ends

## Adjustment for measurement chains

Adjustment	
92ABG	Compensation of measurement chain in the preferred direction of the sensor
92ABG-S	Compensation of measurement chain according to customer request

## Calibration certificate with accreditation symbol

Calibration certificate with accreditation symbol for instrumentation amplifier 9236. The calibration is based on the accreditation of the calibration laboratory D-K-15141-01-00 for the scope of accreditation listed in the annex. The traceability to national standards as well as wide international recognition (DAkkS as a signatory of the multilateral agreements of EA, ILAC and IAF) are guaranteed.



## Calibration certificates for instrumentation amplifiers

Standard factory calibration certificate for instrumentation amplifiers (WKS)	
On request	Calibration is performed by electrical simulation of the input variables.
Calibration certificate with accreditation symbol for instrumentation amplifiers (DKD)	
On request	Our ISO 17025 accredited calibration laboratory (DAkkS) offers accredited calibrations in accordance with its scope of services. Calibration is performed by electrical simulation of the input variables.

## Calibration certificates for measurement chains

Standard factory calibration certificate for measurement chains (WKS)	
Optional available	<p>Normally, our standard factory calibration certificate contains measuring points which are recorded starting from zero in 5 steps (distributed as evenly as possible over the measuring range) until the nominal sensor value is reached. In this process, the change of the physical input variable takes place with increasing and decreasing signal with unchanged installation position of the sensor.</p> <p>Calibration is performed in conjunction with a transducer (sensor) for physical quantities and is based on the procedure specified in the sensor data sheet.</p>
Special factory calibration certificate for measurement chains (WKS)	
On request	We are happy to calibrate sensors and measurement chains to the customer's specification.
Calibration certificate with accreditation symbol for measurement chains (DKD)	
Optional available	<p>Our ISO 17025 accredited calibration laboratory (DAkkS) offers accredited calibration certificates according to its scope of services. The applied calibration procedures can also be taken from the data sheet of the used transducer (sensor).</p> <p>Calibration is performed in conjunction with a transducer (sensor) for physical quantities</p>

## Order code

Order number	
8526-6001-S000S000	Compression load cell model 8526, measuring range 1 kN, characteristic value standardized to 1.0 mV/V
9236-V001	Model 9236 instrumentation amplifier, pluggable on the output side using an M12 connector
92ABG	Calibration of measuring chain
9900-K303	Connection cable with M12 connector, length 3m

## Order Code

	9	2	3	6	-	V		0	
■ IP67 with PG screw connections							0	0	0
■ IP67 with M12 connectors							0	0	1
■ Open circuit board							1	0	0
■ 2-channel							2	0	0
■ 3-channel							3	0	0
■ 4-channel							4	0	0