

MV-IDH3013

1.3 MP Wired Handheld Code Reader



Introduction

MV-IDH3013 wired handheld code reader adopts code reading algorithm and can read different types of one-dimensional and two-dimensional codes, and output results rapidly. It has good decoding capability for codes with spots, defects and low contrast radio, and entry level DPM code.

Key Feature

- Adopts code reading algorithm to read different types of one-dimensional and two-dimensional codes.
- Provides good robustness to read codes with spots, defects and low contrast radio.
- Supports continuous code reading, batch code reading for improving code reading efficiency.
- Supports multiple communication protocols, including TCP, Serial, FTP, UDP, USB HID, etc.
- Easy to replace components.

Applicable Industry

Consumer electronics, medical treatment, appliance manufacturing, etc.

Available Model

- Fast Ethernet with near distance: MV-IDH3013-05N-R1L
- Fast Ethernet with standard distance: MV-IDH3013-05S-R1L
- USB interface with near distance: MV-IDH3013-05N-R1U
- USB interface with standard distance: MV-IDH3013-05S-R1U

Dimension

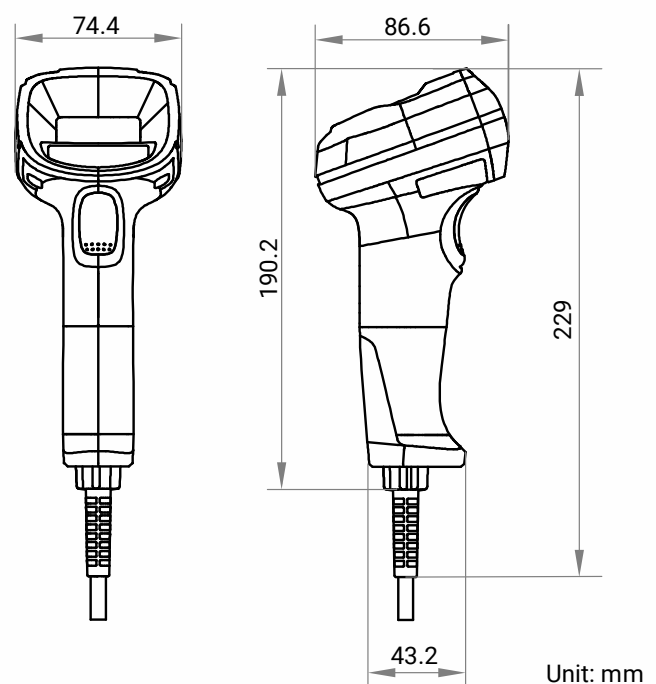

Specification

Model	MV-IDH3013-05N-R1L(U)	MV-IDH3013-05S-R1L(U)
Performance		
Symbologies	1-dimensional codes: Code 39, Code 93, Code 128, CodaBar, EAN 8, EAN 13, Matrix 2 of 5, ITF 14, UPCA, UPCE	
	2-dimensional codes: QR Code, Data Matrix	
Min. accuracy	3 mil	4 mil
Max. frame rate	50 fps	
Sensor type	CMOS, global shutter	
Pixel size	2.7 μm \times 2.7 μm	
Sensor size	1/4"	
Resolution	1280 \times 1024	
Depth of field*	Code 128 (3 mil): 35 mm to 80 mm Code 128 (10 mil): 10 mm to 170 mm Code 39 (5 mil): 15 mm to 100 mm Code 39 (20 mil): 20 mm to 250 mm Data Matrix (10 mil): 5 mm to 115 mm QR Code (20 mil): 20 mil to 190 mm	Code 39 (5 mil): 40 mm to 160 mm Code 128 (10 mil): 10 mm to 400 mm Data Matrix (10 mil): 30 mm to 200 mm QR Code (15 mil): 15 mm to 280 mm QR Code (20 mil): 20 mm to 370 mm
Field of view	Horizontal 40°, vertical 34°	
Detection angle	Tilt angle \pm 60°, skew angle \pm 60°, rotation angle 360°	
Symbol contrast	20%	
Communication protocol	Fast Ethernet type device: SmartSDK, TCP Client, FTP, TCP Server, UDP, Serial USB type device: SmartSDK, USB (HID/CDC)	
Electrical feature		
Data interface	Fast Ethernet type device: Fast Ethernet, RS-232, DC terminal USB type device: USB2.0, DC terminal	
Power supply	Fast Ethernet type device: 12 VDC to 24 VDC USB type device: 5 VDC (USB), 12 VDC to 24 VDC (DC terminal)	
Max. power consumption	Fast Ethernet type device: 1.75 W@12 VDC USB type device: 1.5 W@5 VDC (USB), 1.8 W@12 VDC (DC terminal)	
Mechanical		
Focal length	4.7 mm	
Lens mount	M5.8-mount	
Ambient illumination	0 lux to 100000 lux	
Light source	Red LED	
Aiming system	Cross laser aiming	
Dimension	74.4 mm \times 86.6 mm \times 190.2 mm (2.9" \times 3.4" \times 7.5")	
Weight	Approx. 160 g (0.4 lb.)	
Ingress protection	IP42	
Temperature	Working temperature: -20 °C to 50 °C (-4 °F to 122 °F) storage temperature: -40 °C to 70 °C (-40°F to 158 °F)	
Humidity	20% to 80% RH, non-condensing	
Drop height	1.5 m (59.1"), 50 times	



Specification

General	
Client software	IDMVS
Certification	CE, KC
<i>*Test condition: Environment temperature=25 °C (77 °F), ambient illumination=250 lux filament lamp, Hikrobot's test symbologies are used.</i>	