

MV-CE020-10GC

2 MP 1/2.8" CMOS GigE Area Scan Camera



GEN*i*CAM

GIG*E*
VISION

Introduction

MV-CE020-10GC camera adopts Sony® IMX290 sensor to provide high-quality images. It uses GigE interface to transmit non-compressed images in real time, and its max. frame rate can reach 58 fps in full resolution.

Key Feature

- Adopts GigE interface and max. transmission distance of 100 meters without relay.
- Supports auto and manual adjustment for exposure time, LUT, Gamma correction, etc.
- Supports hardware trigger, software trigger, etc.
- Compatible with GigE Vision V2.0 Protocol, GeniCam Standard, and third-party software based on the protocol and standard.

Dimension

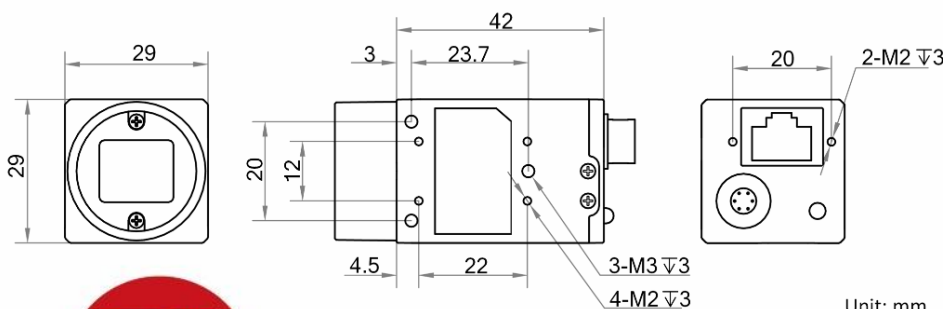

Available Model

MV-CE020-10GC

Applicable Industry

Electronic semiconductor, factory automation, food and beverage, medical packaging, etc.

Sensor Quantum Efficiency

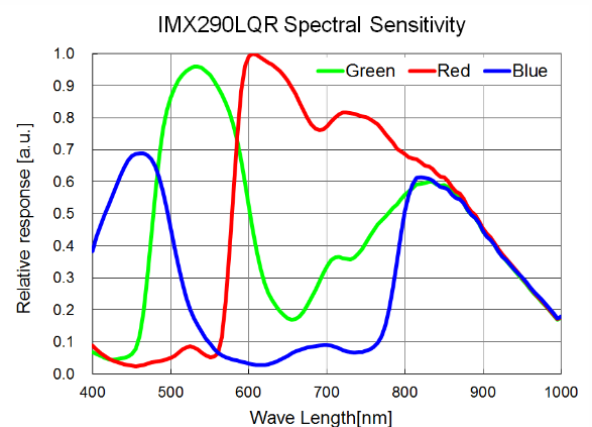

Specification

Model	MV-CE020-10GC
Camera	
Sensor type	CMOS, rolling shutter
Sensor model	Sony® IMX290
Pixel size	2.9 μm × 2.9 μm
Sensor size	1/2.8"
Resolution	1920 × 1080
Max. frame rate	58 fps @1920 × 1080
Dynamic range	74 dB
SNR	38 dB
Gain	0 dB to 20 dB
Exposure time	15 μs to 2 sec
Exposure mode	Off/Once/Continuous exposure mode, supports Global Reset and Rolling
Mono/color	Color
Pixel format	Mono 8/10/12, Bayer RG 8/10/10p/12/12p, YUV422Packed, YUV422_YUYV_Packed, RGB 8, BGR 8
Binning	Supports 1 × 1, 2 × 2
Decimation	Supports 1 × 1, 2 × 2
Reverse image	Supports horizontal and vertical reverse image output
Electrical feature	
Data interface	Gigabit Ethernet, compatible with Fast Ethernet
Digital I/O	6-pin Hirose connector provides power and I/O, including opto-isolated input × 1 (Line 0), opto-isolated output × 1 (Line 1), bi-directional non-isolated I/O × 1 (Line 2).
Power supply	9 VDC to 24 VDC, supports PoE
Power consumption	Typ. 2.4 W@12 VDC
Mechanical	
Lens mount	C-Mount
Dimension	29 mm × 29 mm × 42 mm (1.1" × 1.1" × 1.7")
Weight	Approx. 68 g (0.15 lb.)
Ingress protection	IP30 (under proper lens installation and wiring)
Temperature	Working temperature: 0 °C to 50 °C (32 °F to 122 °F) Storage temperature: -30 °C to 70 °C (-22 °F to 158 °F)
Humidity	20% to 80% RH, non-condensing
General	
Client software	MVS or third-party software meeting with GigE Vision Protocol
Operating system	32/64-bit Windows XP/7/10, 32/64-bit Linux and 64-bit MacOS
Compatibility	GigE Vision V2.0, GenICam
Certification	CE, RoHS, KC

HIKROBOT

Hangzhou Hikrobot Co., Ltd.
 en.hikrobotics.com

© Hangzhou Hikrobot Co., Ltd. All Rights Reserved.

Hangzhou Hikrobot does not tolerate any infringement. Any organization or individual may not imitate or reproduce in whole or in part of the content. The data herein is based on Hikrobot's internal evaluation. Actual data may vary depending on specific configuration and operating condition. The information herein is subject to change without notice. All the content has been checked conscientiously. Nevertheless, Hikrobot shall not be liable to damages resulting from errors, inconsistencies or omissions.