

ECL150 Multichannel

Compact, Multi-Channel, Built on CompactFLEX Digital Technology

High Performance

- Nonlinearity: 0.2%
- Resolution (RMS): 0.002%–0.025% (Probe/Range dependent)
- Bandwidth: 250 Hz, 1 kHz, 10 kHz, 15 kHz (user selectable)

Features

- ± 5 VDC Outputs
- No User Adjustments
- Range Indicating LEDs
- Up to 8 Channels in One Compact Package
- Available Without Enclosure

Export Limitations

Because of high resolutions, export of the ECL150 to some countries requires an export license. The ECL150e has different resolution specifications and can ship without an export license.



Specifications

Analog Output	± 5 VDC, 0 Ω , 15 mA max 15 μ s update rate
Output Channels	Up to 8. Multiple units can be interconnected for more channels
Input Power	12-24 VDC, 1-2 Channels – 2.5 W 3-4 Channels – 3.5 W 5-6 Channels – 4.5 W 7-8 Channels – 5.5 W
Driver Operating Environment	4°C to 50°C, IP64

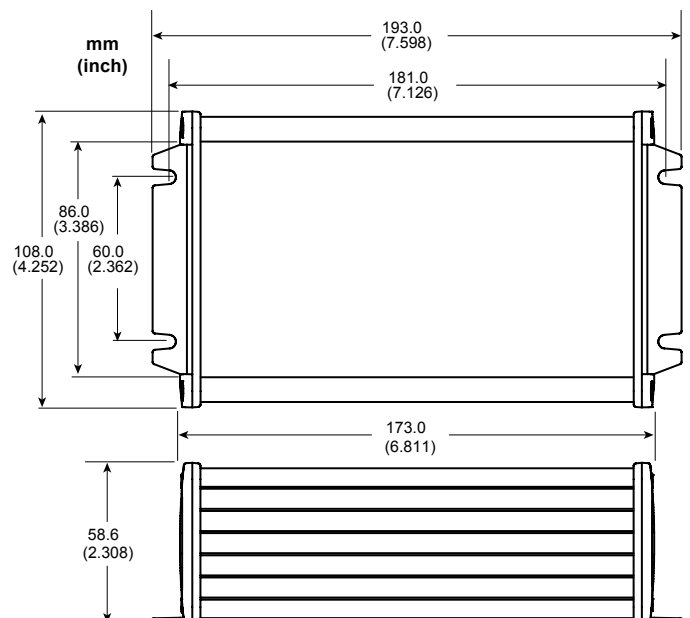

Range, Resolution, Thermal Drift

Specifications based on standard 3 m cable, target size 3 times probe diameter.

Probe Model	Range mm inch	Near Gap mm inch	Material Type	Resolution ¹ @ Bandwidth					Thermal Drift ² %F.S./°C	
				ECL150				³ ECL150e	Probe	Driver
				250 Hz nm μinch	1 kHz nm μinch	10 kHz nm μinch	15 kHz nm μinch	15 kHz nm μinch		
U3	0.50 0.020	0.05 0.002	Nonferrous	35 1.4	45 1.8	60 2.4	65 2.6	400 16	0.04	0.04
			Ferrous	60 2.4	80 3.2	100 4.0	110 4.4	400 16	0.08	0.08
U5	1.25 0.050	0.25 0.010	Nonferrous	75 3.0	100 4.0	140 5.6	150 6.0	400 16	0.04	0.10
			Ferrous	130 5.0	180 7.0	240 9.5	260 10	400 16	0.10	0.10
U8	2.00 0.080	0.35 0.015	Nonferrous	75 3.0	100 4.0	135 5.5	145 6.0	400 16	0.02	0.04
			Ferrous	100 4.0	125 5.0	180 7.0	200 8.0	400 16	0.04	0.04
U12	3.50 0.140	0.60 0.025	Nonferrous	120 4.8	160 6.3	210 9.0	240 10	400 16	0.02	0.01
			Ferrous	150 6.0	200 8.0	250 10	300 12	400 16	0.03	0.01
U18	5.00 0.200	0.75 0.030	Nonferrous	170 7.0	240 10	300 12	340 14	400 16	0.01	0.01
			Ferrous	230 9.0	300 12	390 16	450 18	500 20	0.01	0.01
U25	8.00 0.320	1.25 0.050	Nonferrous	330 13	430 17	600 24	650 26	650 26	0.01	0.01
			Ferrous	360 15	480 20	650 26	750 30	750 30	0.01	0.01
U38	12.5 0.500	1.50 0.060	Nonferrous	600 24	750 30	1000 40	1200 48	1200 47	0.01	0.01
			Ferrous	650 26	800 32	1100 44	1300 52	1300 51	0.02	0.01
U50	15.0 0.600	2.00 0.080	Nonferrous	750 30	1000 40	1300 52	1400 56	1400 55	0.01	0.01
			Ferrous	800 32	1100 45	1400 55	1500 60	1500 59	0.01	0.01

¹Peak-to-Peak resolution is 8-10 times RMS resolution; in high EMI environments (10 V/m), output noise levels could rise to 60 mV RMS (0.6% resolution) and DC level shift by 0.2 VDC. The 'e' version has higher resolution values so it does not require an export license.

²Thermal Drift specified at: Probe: 15°C - 65°C; Driver: 15°C - 50°C

³The ECL150e does not require an export license