

SCARA ROBOT THL900

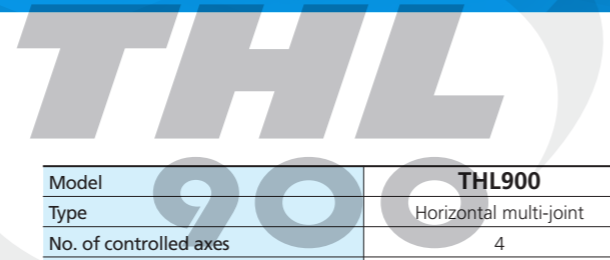

Model		THL900
Type	Horizontal multi-joint	
No. of controlled axes	4	
Arm length	900mm (450mm+450mm)	
Working envelope	Axis 1	±125°
	Axis 2	±145°
	Axis 3 (Z axis)	0~300mm
	Axis 4 (Z-axis rotation)	±360°
Maximum speed*1	Axis 1	187.5°/s
	Axis 2	217.5°/s
	Axis 3 (Z axis)	2000mm/s
	Axis 4 (Z-axis rotation)	1700°/s
	Composite	4.6m/s
Standard cycle time (with 2 kg load)*2	0.48s	
Maximum payload mass	10kg (rated: 2kg)	
Allowable moment of inertia	0.2kg·m ²	
Positioning repeatability*3	X-Y	±0.02mm
	Z (Axis 3)	±0.015mm
	Axis θ (Z-axis rotation)	±0.007°
Hand wiring	8 inputs / 8 outputs	
Hand pneumatic joints*4	φ6 x 3 pcs.	
Position detection	Absolute	
Robot controller cable	3.5m	
Power capacity	1.4kVA	
Mass	35kg	

■For *1 to *4, please see page 5.

SCARA ROBOT THL1000



Model		THL1000
Type	Horizontal multi-joint	
No. of controlled axes	4	
Arm length	1000mm (550mm+450mm)	
Working envelope	Axis 1	±125°
	Axis 2	±145°
	Axis 3 (Z axis)	0~300mm
	Axis 4 (Z-axis rotation)	±360°
Maximum speed*1	Axis 1	187.5°/s
	Axis 2	217.5°/s
	Axis 3 (Z axis)	2000mm/s
	Axis 4 (Z-axis rotation)	1700°/s
	Composite	5.0m/s
Standard cycle time (with 2 kg load)*2	0.48s	
Maximum payload mass	10kg (rated: 2kg)	
Allowable moment of inertia	0.2kg·m ²	
Positioning repeatability*3	X-Y	±0.02mm
	Z (Axis 3)	±0.015mm
	Axis θ (Z-axis rotation)	±0.007°
Hand wiring	8 inputs / 8 outputs	
Hand pneumatic joints*4	φ6 x 3 pcs.	
Position detection	Absolute	
Robot controller cable	3.5m	
Power capacity	1.4kVA	
Mass	37kg	

■For *1 to *4, please see page 5.

External view

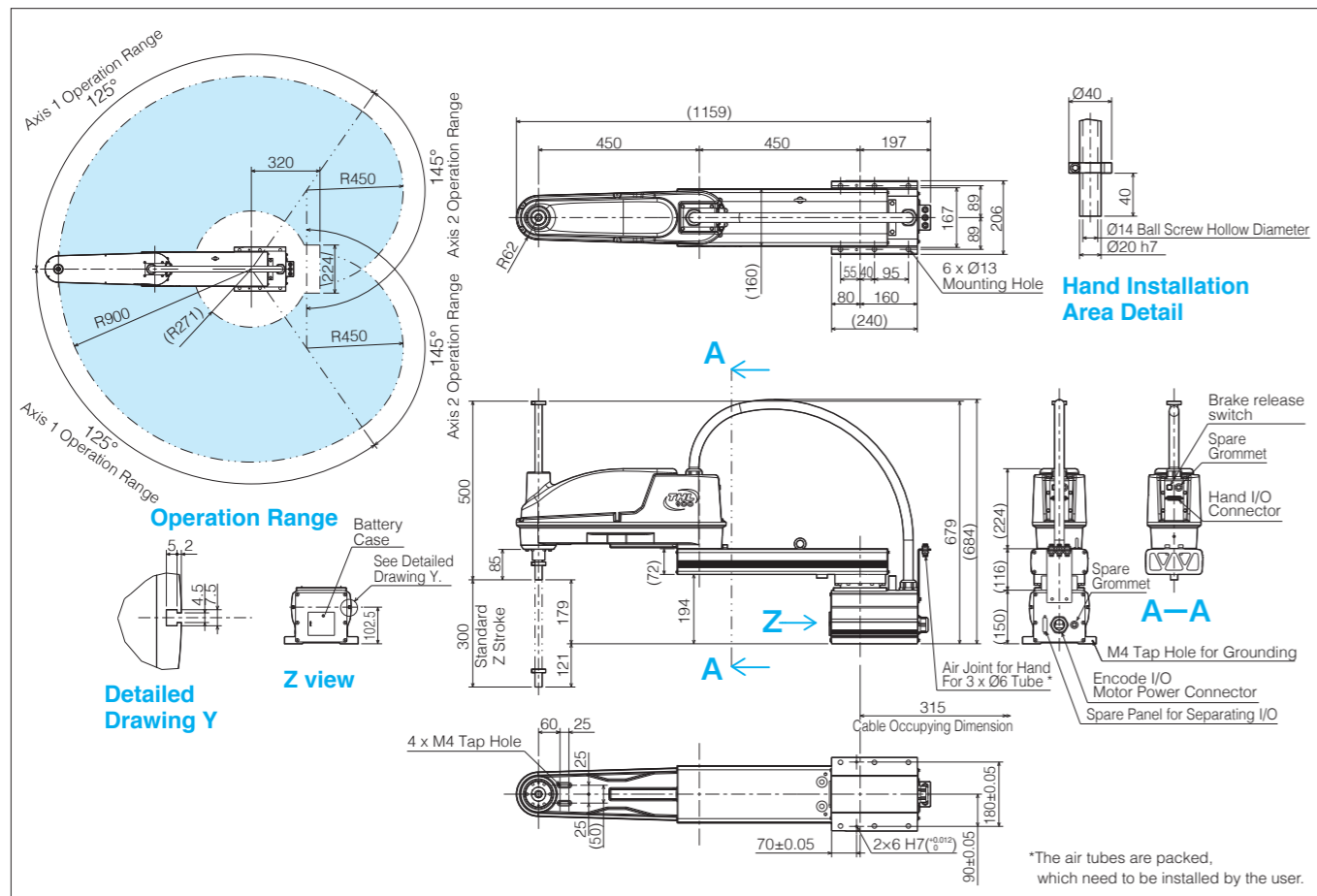

External view

