

PROPRIETARY AND CONFIDENTIAL

THE INFORMATION CONTAINED IN THIS DRAWING IS THE SOLE PROPERTY OF DYTRAN INSTRUMENTS INC. ANY REPRODUCTION IN PART OR AS A WHOLE WITHOUT THE WRITTEN PERMISSION OF DYTRAN INSTRUMENTS INC. IS PROHIBITED

REVISIONS

REV.	ECN	DESCRIPTION	BY/DATE	CHK	APPR
A	10603	INITIAL RELEASE	RA, 07/18/14	ER	RA

SYSTEM	REV	ECN	DATE	ACCELEROMETER	RANGE
5346A1	A	10603	07/18/14	7546A1	±14 G RANGE
5346A2	A	10603	07/18/14	7546A2	±200 G RANGE

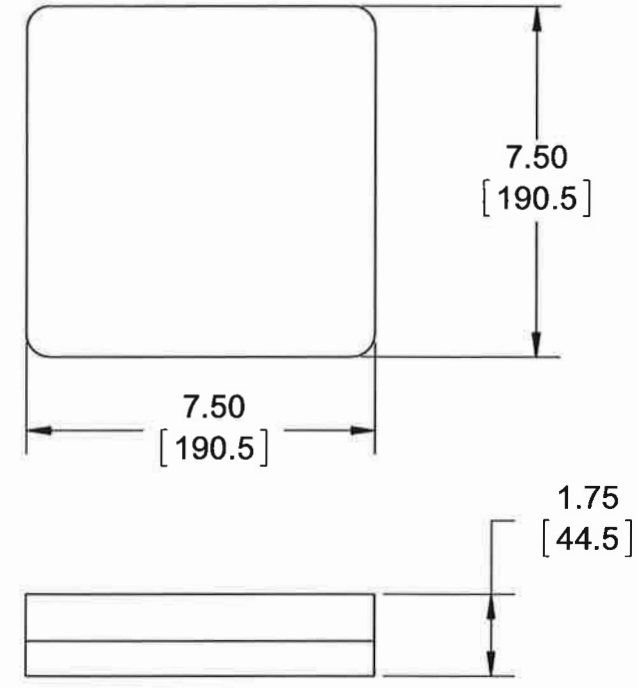
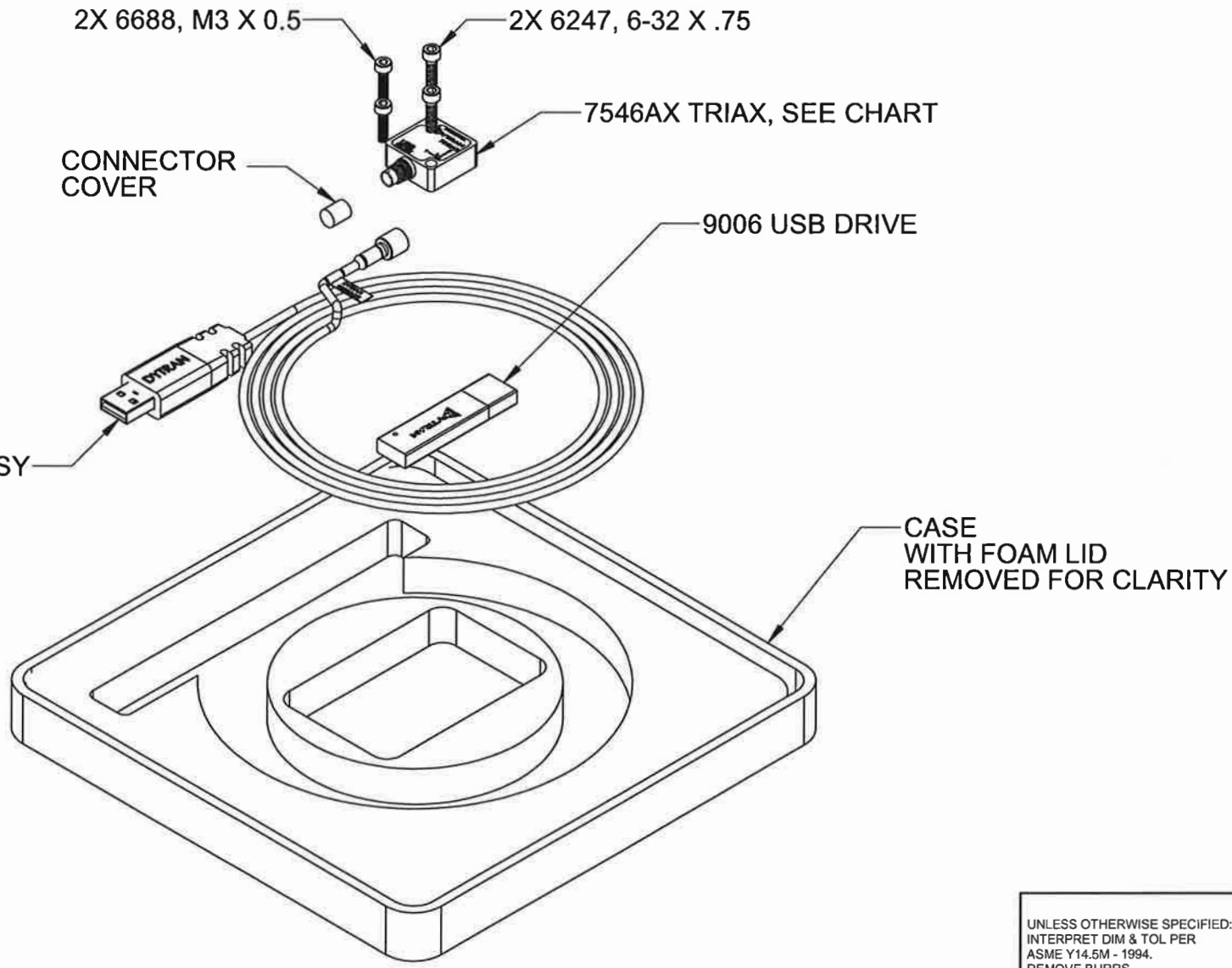

UNLESS OTHERWISE SPECIFIED:
 INTERPRET DIM & TOL PER ASME Y14.5M - 1994.
 REMOVE BURRS.
 COUNTERSINK INTERNAL THDS 90° TO MAJOR DIA.
 CHAM EXT THDS 45° TO MINOR DIA.
 THD LENGTHS AND DEPTHS ARE FOR MIN FULL THDS.
 DIMENSIONS APPLY AFTER FINISHING.

ALL MACHINED SURFACES. ⁶³✓
 TOTAL RUNOUT WITHIN .005.
 BREAK SHARP EDGES .005 TO .010.
 MACHINED FILLET RADII .005 TO .015.
 WELDING SYMBOLS PER AWS A2.4.
 ABBREVIATIONS PER MIL-STD-12.

UNLESS OTHERWISE SPECIFIED:
 DIMENSIONS ARE IN INCHES.
 DIMENSIONS IN BRACKETS [] ARE IN MILLIMETERS TOLERANCES ARE:

DECIMALS	METRIC	ANGLES
.XX ±.03	.X ± 0.8	±1°
.XXX ±.010	.XX ± 0.25	

APPROVALS		DATE
ORIG	RA	1/13/14
CHK	ER	7/21/14
APP	TR	7/22/14

DO NOT SCALE DRAWING

DYTRAN INSTRUMENTS, INC. Chatsworth, CA

MASTER ONLY IF IN RED

TITLE: **OUTLINE/INSTALLATION DRAWING, TRIAXIAL USB, 5346A SERIES**

SIZE	CAGE CODE	DWG NO	REV
B	2W033	127-5346A	A

SCALE: 1:4 SHEET 1 OF 1

NOTES: UNLESS OTHERWISE SPECIFIED

PROPRIETARY AND CONFIDENTIAL

THE INFORMATION CONTAINED IN THIS DRAWING IS THE SOLE PROPERTY OF DYTRAN INSTRUMENTS INC. ANY REPRODUCTION IN PART OR AS A WHOLE WITHOUT THE WRITTEN PERMISSION OF DYTRAN INSTRUMENTS INC. IS PROHIBITED

MODEL	REV	ECN	DATE	RANGE
7546A1	A	10603	07/18/14	14G
7546A2	A	10603	07/18/14	200G

REVISIONS

REV.	ECN	DESCRIPTION	BY/DATE	CHK	APPR
A	10603	INITIAL RELEASE	RA, 0718/14	[Signature]	[Signature]

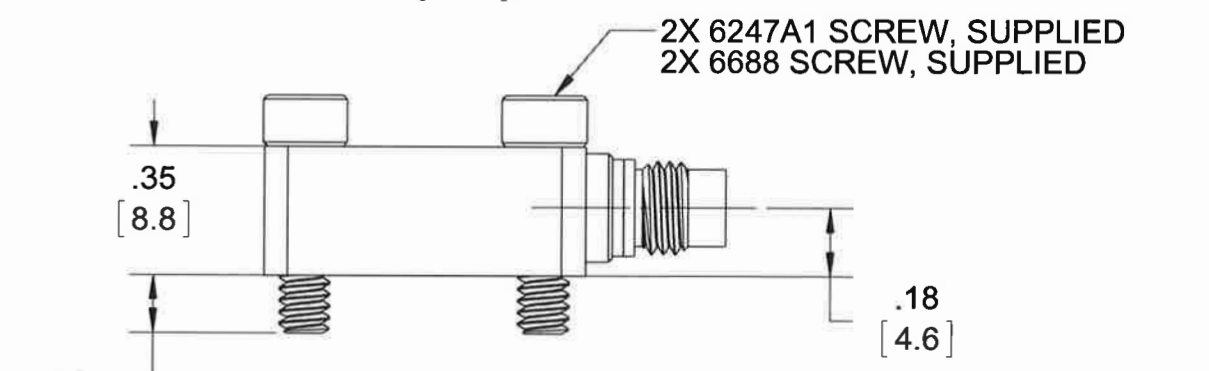
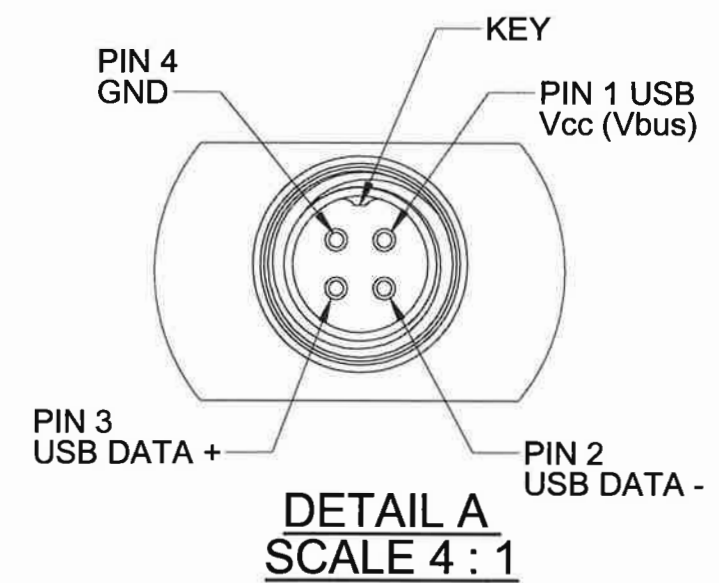
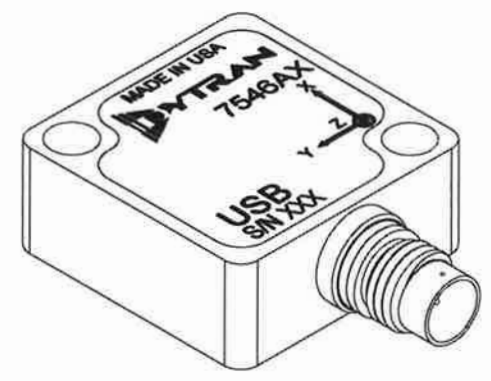
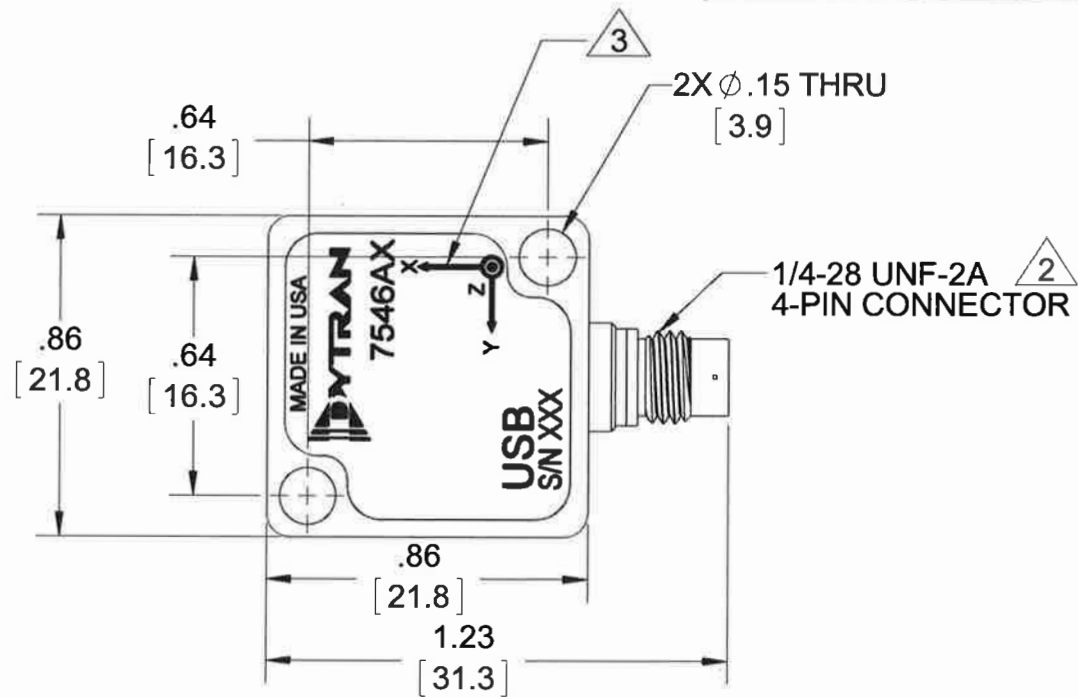

2X 6247A1 MOUNTING 6-32 X .25 MIN DEEP
OR
2X 6688 MOUNTING M3X 0.5 X .25 MIN DEEP

ENSURE SURFACE FLATNESS BETTER THAN .001 TIR. MOUNTING TORQUE 6-8 Lb-in.

- 3 ARROW INDICATES DIRECTION OF ACCELERATION OR POSITIVE OUTPUT.
- 2 MATES WITH DYTRAN CABLE P/N 6330AXX.

1. WEIGHT: 13 GRAMS, MAX

NOTES: UNLESS OTHERWISE SPECIFIED

UNLESS OTHERWISE SPECIFIED: INTERPRET DIM & TOL PER ASME Y14.5M - 1994. REMOVE BURRS. COUNTERSINK INTERNAL THDS 90° TO MAJOR DIA. CHAM EXT THDS 45° TO MINOR DIA. THD LENGTHS AND DEPTHS ARE FOR MIN FULL THDS. DIMENSIONS APPLY AFTER FINISHING.	UNLESS OTHERWISE SPECIFIED: DIMENSIONS ARE IN INCHES. DIMENSIONS IN BRACKETS [] ARE IN MILLIMETERS TOLERANCES ARE:		DYTRAN INSTRUMENTS, INC. Chatsworth, CA		MASTER ONLY IF IN RED		
	DECIMALS .XX ±.03 .XXX ±.010	METRIC X ± 0.8 .XX ±0.25	ANGLES ±1°	TITLE: OUTLINE/INSTALLATION DRAWING, TRIAXIAL USB, 7546A SERIES			
	APPROVALS		DATE			SIZE B	
	ORIG RA CHK [Signature] APP [Signature]	03/21/14 7/21/14 7/22/14		CAGE CODE 2W033		DWG NO 127-7546A	
ALL MACHINED SURFACES TOTAL RUNOUT WITHIN .005. BREAK SHARP EDGES .005 TO .010. MACHINED FILLET RADII .005 TO .015. WELDING SYMBOLS PER AWS A2.4. ABBREVIATIONS PER MIL-STD-12.			DO NOT SCALE DRAWING	THIRD ANGLE PROJECTION USA	SCALE: 2:1	REV A	SHEET 1 OF 1

Model Number 7546A2	PERFORMANCE SPECIFICATION				DOC NO PS7546A2																																				
	VibraScout 6D (200G)				REV A, ECN 10603, 07/21/14																																				
	<ul style="list-style-type: none"> • USB PROTOCOL • MEMS TECHNOLOGY • EMBEDDED MICROCONTROLLER • HERMETICALLY SEALED • ACCELERATION AND GYRO RESPONSE 				This family also includes: <table border="1"> <thead> <tr> <th>Model</th> <th>Input Range (g)</th> <th>Frequency response (Hz)</th> <th>Non-Linearity (%F.S)</th> <th>Max.Shock</th> <th>Noise ($\mu\text{g}/\sqrt{\text{Hz}}$)</th> </tr> </thead> <tbody> <tr> <td>7546A1</td> <td>14</td> <td>1,100</td> <td>0.5</td> <td>10000</td> <td>TBD</td> </tr> <tr> <td></td> <td></td> <td></td> <td></td> <td></td> <td></td> </tr> <tr> <td></td> <td></td> <td></td> <td></td> <td></td> <td></td> </tr> <tr> <td></td> <td></td> <td></td> <td></td> <td></td> <td></td> </tr> <tr> <td></td> <td></td> <td></td> <td></td> <td></td> <td></td> </tr> </tbody> </table>	Model	Input Range (g)	Frequency response (Hz)	Non-Linearity (%F.S)	Max.Shock	Noise ($\mu\text{g}/\sqrt{\text{Hz}}$)	7546A1	14	1,100	0.5	10000	TBD																								
	Model	Input Range (g)	Frequency response (Hz)	Non-Linearity (%F.S)	Max.Shock	Noise ($\mu\text{g}/\sqrt{\text{Hz}}$)																																			
7546A1	14	1,100	0.5	10000	TBD																																				
PHYSICAL Weight, Max Connector [2] Material	<table border="1"> <thead> <tr> <th>ENGLISH</th> <th></th> <th>SI</th> <th></th> </tr> </thead> <tbody> <tr> <td>0.5</td> <td>oz</td> <td>13</td> <td>grams</td> </tr> <tr> <td>1/4-28UNF</td> <td></td> <td>1/4-28UNF</td> <td></td> </tr> <tr> <td>Ti-6Al-4V</td> <td></td> <td>Ti-6Al-4V</td> <td></td> </tr> </tbody> </table>	ENGLISH		SI		0.5	oz	13	grams	1/4-28UNF		1/4-28UNF		Ti-6Al-4V		Ti-6Al-4V																									
ENGLISH		SI																																							
0.5	oz	13	grams																																						
1/4-28UNF		1/4-28UNF																																							
Ti-6Al-4V		Ti-6Al-4V																																							
ACCELEROMETER PERFORMANCE Input Range +/- Frequency Response, +/- 10% Frequency Response (3dB), Nominal [3] Freq. Tol. Over Temp (0.5 Deg C/min) Output Noise, Maximum Non-Linearity, Typical Cross Axis Sensitivity, Typical	<table border="1"> <thead> <tr> <th>ENGLISH</th> <th></th> <th>SI</th> <th></th> </tr> </thead> <tbody> <tr> <td>200</td> <td>g</td> <td>1962.0</td> <td>m/s^2</td> </tr> <tr> <td>0 - 500</td> <td>Hz</td> <td>0 - 500</td> <td>Hz</td> </tr> <tr> <td>0 - 1100</td> <td>Hz</td> <td>0 - 1100</td> <td>Hz</td> </tr> <tr> <td>0.50</td> <td>%</td> <td>0.50</td> <td>%</td> </tr> <tr> <td>6,000</td> <td>$\mu\text{g rms}/\sqrt{\text{Hz}}$</td> <td>58,860</td> <td>$\mu\text{m/s}^2/\sqrt{\text{Hz}}$</td> </tr> <tr> <td>0.5</td> <td>% F.S</td> <td>0.5</td> <td>% F.S</td> </tr> <tr> <td>2</td> <td>%F.S.</td> <td>2</td> <td>% F.S.</td> </tr> </tbody> </table>	ENGLISH		SI		200	g	1962.0	m/s^2	0 - 500	Hz	0 - 500	Hz	0 - 1100	Hz	0 - 1100	Hz	0.50	%	0.50	%	6,000	$\mu\text{g rms}/\sqrt{\text{Hz}}$	58,860	$\mu\text{m/s}^2/\sqrt{\text{Hz}}$	0.5	% F.S	0.5	% F.S	2	%F.S.	2	% F.S.								
ENGLISH		SI																																							
200	g	1962.0	m/s^2																																						
0 - 500	Hz	0 - 500	Hz																																						
0 - 1100	Hz	0 - 1100	Hz																																						
0.50	%	0.50	%																																						
6,000	$\mu\text{g rms}/\sqrt{\text{Hz}}$	58,860	$\mu\text{m/s}^2/\sqrt{\text{Hz}}$																																						
0.5	% F.S	0.5	% F.S																																						
2	%F.S.	2	% F.S.																																						
GYROSCOPE PERFORMANCE Input Range +/- Frequency Response +/-3dB Output Noise, Maximum Non-Linearity, Typical (@ 25C) Cross Axis Sensitivity, Typical +/- Zero-Rate Output +/-	<table border="1"> <thead> <tr> <th>ENGLISH</th> <th></th> <th>SI</th> <th></th> </tr> </thead> <tbody> <tr> <td>2000</td> <td>$^{\circ}/\text{s}$</td> <td>2000</td> <td>$^{\circ}/\text{s}$</td> </tr> <tr> <td>0-250</td> <td>Hz</td> <td>0-250</td> <td>Hz</td> </tr> <tr> <td>0.05</td> <td>$^{\circ}/\text{s}/\sqrt{\text{Hz}}$</td> <td>0.05</td> <td>$^{\circ}/\text{s}/\sqrt{\text{Hz}}$</td> </tr> <tr> <td>0.2</td> <td>%F.S.</td> <td>0.2</td> <td>%F.S.</td> </tr> <tr> <td>2</td> <td>%F.S.</td> <td>2</td> <td>%F.S.</td> </tr> <tr> <td>20</td> <td>$^{\circ}/\text{s}$</td> <td>20</td> <td>$^{\circ}/\text{s}$</td> </tr> </tbody> </table>	ENGLISH		SI		2000	$^{\circ}/\text{s}$	2000	$^{\circ}/\text{s}$	0-250	Hz	0-250	Hz	0.05	$^{\circ}/\text{s}/\sqrt{\text{Hz}}$	0.05	$^{\circ}/\text{s}/\sqrt{\text{Hz}}$	0.2	%F.S.	0.2	%F.S.	2	%F.S.	2	%F.S.	20	$^{\circ}/\text{s}$	20	$^{\circ}/\text{s}$												
ENGLISH		SI																																							
2000	$^{\circ}/\text{s}$	2000	$^{\circ}/\text{s}$																																						
0-250	Hz	0-250	Hz																																						
0.05	$^{\circ}/\text{s}/\sqrt{\text{Hz}}$	0.05	$^{\circ}/\text{s}/\sqrt{\text{Hz}}$																																						
0.2	%F.S.	0.2	%F.S.																																						
2	%F.S.	2	%F.S.																																						
20	$^{\circ}/\text{s}$	20	$^{\circ}/\text{s}$																																						
ENVIRONMENTAL Maximum Mechanical Shock Operating Temperature Range Scale Factor Temperature Shift [1] Seal	<table border="1"> <thead> <tr> <th>ENGLISH</th> <th></th> <th>SI</th> <th></th> </tr> </thead> <tbody> <tr> <td>± 10000</td> <td>gpk</td> <td>± 98100</td> <td>m/s^2 peak</td> </tr> <tr> <td>-40 to +185</td> <td>$^{\circ}\text{F}$</td> <td>-40 to +85</td> <td>$^{\circ}\text{C}$</td> </tr> <tr> <td>-56 to +56</td> <td>ppm/$^{\circ}\text{F}$</td> <td>-100 to +100</td> <td>ppm/$^{\circ}\text{C}$</td> </tr> <tr> <td>Hermetic</td> <td></td> <td>Hermetic</td> <td></td> </tr> </tbody> </table>	ENGLISH		SI		± 10000	gpk	± 98100	m/s^2 peak	-40 to +185	$^{\circ}\text{F}$	-40 to +85	$^{\circ}\text{C}$	-56 to +56	ppm/ $^{\circ}\text{F}$	-100 to +100	ppm/ $^{\circ}\text{C}$	Hermetic		Hermetic																					
ENGLISH		SI																																							
± 10000	gpk	± 98100	m/s^2 peak																																						
-40 to +185	$^{\circ}\text{F}$	-40 to +85	$^{\circ}\text{C}$																																						
-56 to +56	ppm/ $^{\circ}\text{F}$	-100 to +100	ppm/ $^{\circ}\text{C}$																																						
Hermetic		Hermetic																																							
ELECTRICAL Operating Voltage Power Supply Rejection Ratio, Typical	<table border="1"> <thead> <tr> <th>ENGLISH</th> <th></th> <th>SI</th> <th></th> </tr> </thead> <tbody> <tr> <td>3.8 to 6.0</td> <td>VDC</td> <td>3.8 to 6.0</td> <td>VDC</td> </tr> <tr> <td>44</td> <td>dB</td> <td>44</td> <td>dB</td> </tr> </tbody> </table>	ENGLISH		SI		3.8 to 6.0	VDC	3.8 to 6.0	VDC	44	dB	44	dB																												
ENGLISH		SI																																							
3.8 to 6.0	VDC	3.8 to 6.0	VDC																																						
44	dB	44	dB																																						

Refer to the performance specifications of the products in this family for detailed description.

Device Features:

Dytran model 7546A2 is a unique and innovative solution for fast and cost effective data acquisition. The only addition that is required is a personal computer and it is ready to take data. Model 7546A2 is USB powered, so no additional external power supply is required. The software package supplied with each sensor allows for real time, three directional acceleration acquisition along with temperature data and angular velocity measurement. The standard USB protocol handles all the sensor communications with the PC and provides the following information: storage of the acceleration, gyro, and temperature information, storage of inclination data, real-time scrolling plots of acceleration data with display of min, max, instant values. Logging of real time data to a binary file for high data compression and long recording durations. Post processing using the provided data reduction toolkit for overall FFT, CPB, and test log plots and ascii data.

Supplied Accessories:

- 1) Accredited calibration certificate (ISO 17025)
- 2) Mounting screw model 6247 (Inch), qty 2 and 6688 (Metric), qty2

Notes:

- [1] Over the rated Temperature Ramp Rate (accelerometer only) .
- [2] Mates with Dytran cable assembly 6330AXX ("XX = Length in FT)
- [3] Accelerometer bandwidth is 1.1KHz. Gyro Bandwidth is 250Hz
- [4] In the interest of constant product improvement, we reserve the right to change specifications without notice.
- [5] Minimum computer requirements: Intel Core i5, RAM:4GB, HDD:40GB, Win Vista-8 (32/64bit), USB2.0

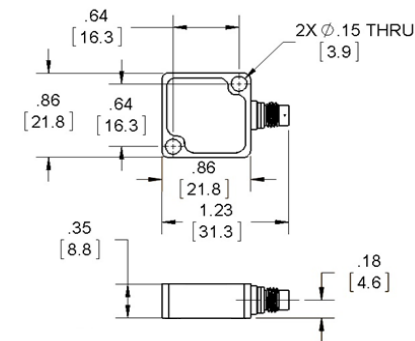

Units on the line drawing are in inches. Refer to 127-7546A for more information.



21592 Marilla Street, Chatsworth, California 91311 Phone: 818.700.7818 Fax:818.700.7880 www.dytran.com
 For permission to reprint this content, please contact info@dytran.com



Presented by: Absolute Gauge Technologies
 sales@absolute-gauge.com; www.absolute-gauge.com,
 Toronto: 416 754 3168, Montreal: 514 695 5147, Toll Free: 1 888 754 7008



Dynamic Transducers and Systems
21592 Marilla St. • Chatsworth, CA 91311 • Phone 818-700-7818
www.dytran.com • e-mail: info@dytran.com

OG5346A
REV A, 4/28/2014 ECN10603

Operating Guide

5346A USB Vibration Measurement System

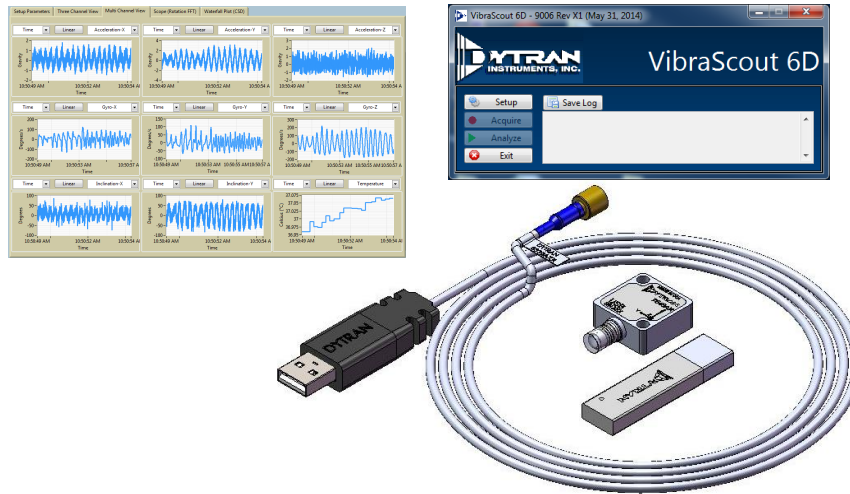

Featuring the

7546A USB Accelerometer

and

VibraScout™ 6D Software Application



Presented by: Absolute Gauge Technologies
sales@absolutegauge.com; www.absolutegauge.com,
Toronto: 416 754 3168, Montreal: 514 695 5147, Toll Free: 1 888 754 7008



Contents

I. Device Features	3
II. VibraScout™ 6D Software Features.....	3
III. Acronyms used in this manual	4
IV. Minimum System Requirements.....	4
V. Installation.....	5
VI. Operation	7
VII. Custom Applications.....	20
VIII. Software License, Restrictions, and Disclaimer.....	21



Presented by: Absolute Gauge Technologies
sales@absolute-gauge.com; www.absolute-gauge.com,
Toronto: 416 754 3168, Montreal: 514 695 5147, Toll Free: 1 888 754 7008



The Dytran 7546A USB Digital 6 degrees of freedom transducer combines a 3-axes MEMS accelerometer, 3-axes gyroscope, and onboard temperature sensor with a microcontroller to create an intelligent sensor.

I. Device Features

-System components:

- USB 7546A Accelerometer
- 6330A 4-pin to USB cable
- 9006 Software Toolkit

-The 7546A is powered by a PC's USB bus.

-Temperature sensor.

-Real-time acquisition and USB transfer of acceleration (including Static Inclination), 3 axes gyro, and temperature data.

-Built-in firmware handles USB communication and provides a number of unique features including:

- Storage of device serial number

- Storage of accelerometer, gyro and temperature calibration data

II. VibraScout™ 6D Software Features

- Real time display of acceleration, gyro and temperature data with 5 seconds of buffer.
- Three channel, Multi channel, Scope (Rotating Machinery) and real time waterfall plots available at runtime.
- Min, Max, Instant measurement values displayed for all 9 channels at runtime.
- User selectable Frequency settings for windowing and frequency range settings.
- Imperial or Standard engineering units for all channels. Unit conversion is selectable by user.
- Embedded post processor for data export to ASCII, UFF58, Matlab compatible .MAT and JPEG files.
- Plot overlays for channel to channel comparison.
- API available as .NET dll



Presented by: Absolute Gauge Technologies
sales@absolute-gauge.com; www.absolute-gauge.com,
Toronto: 416 754 3168, Montreal: 514 695 5147, Toll Free: 1 888 754 7008



III. Acronyms used in this manual

GUI- Graphical User Interface

USB- Universal Serial Bus

FFT- Fast Fourier Transform

PSD-Power Spectral Density

JPG-Joint Photographic File format

ASCII-American Standard Code for Information Interchange

TDMS-Technical Data Management Solution (Binary and ASCII file saving option for smaller file sizes with stored header information)

UFF58- Universal File Format 58 (purely binary file format for data recording)

CPB- Constant percentage bandwidth

MAT- Matlab Compatible data file

IV. Minimum System Requirements

Desktop or a Laptop x86 based personal computer

Operating System: Windows Vista/Seven/Win8 32-bit

CPU: Intel i5 or better

RAM: 4 GB

Hard Disk space: 1 GB

USB 2.0

Display Resolution 1280×780.



Presented by: Absolute Gauge Technologies

sales@absolute-gauge.com; www.absolute-gauge.com,

Toronto: 416 754 3168, Montreal: 514 695 5147, Toll Free: 1 888 754 7008



V. Installation

Insert USB flash drive into an available USB port (If Autorun is enabled, computer will automatically run the Autorun menu as shown in

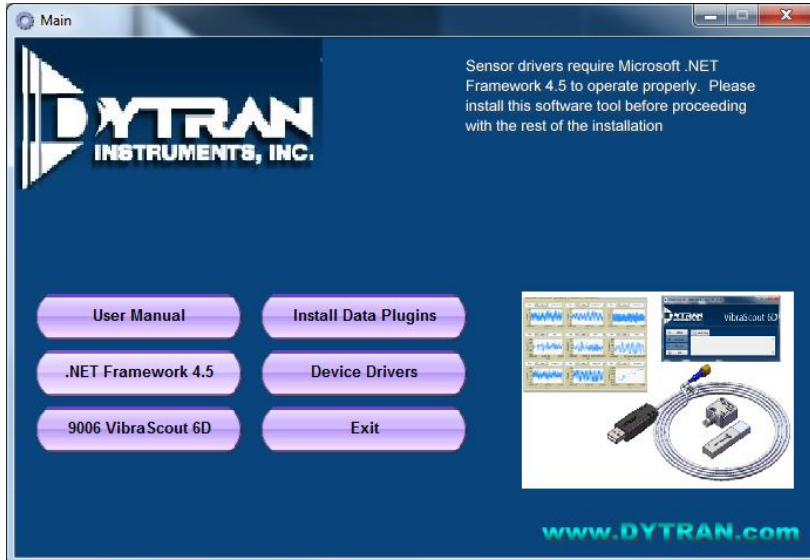

Figure 1 which will provide one click access to installation files). If Autorun is disabled, from <My Computer> double click on the USB drive letter, navigate to Autorun.exe.

If this is the first time using this installation, click on .NET Framework 4.5 and install it in order to properly install the VibraScout software. .NET Framework 4.5 will enable proper installation of the device driver of the USB sensor and proper communication to the on board memory. A system reboot might be required to continue with the rest of the installation.

Click .NET Framework 4.5 to run the setup file. Follow the on-screen instructions selecting all the defaults to complete the installation of the .NET Framework. System reboot is required after completing installation.



Presented by: Absolute Gauge Technologies
sales@absolute-gauge.com; www.absolute-gauge.com,
Toronto: 416 754 3168, Montreal: 514 695 5147, Toll Free: 1 888 754 7008

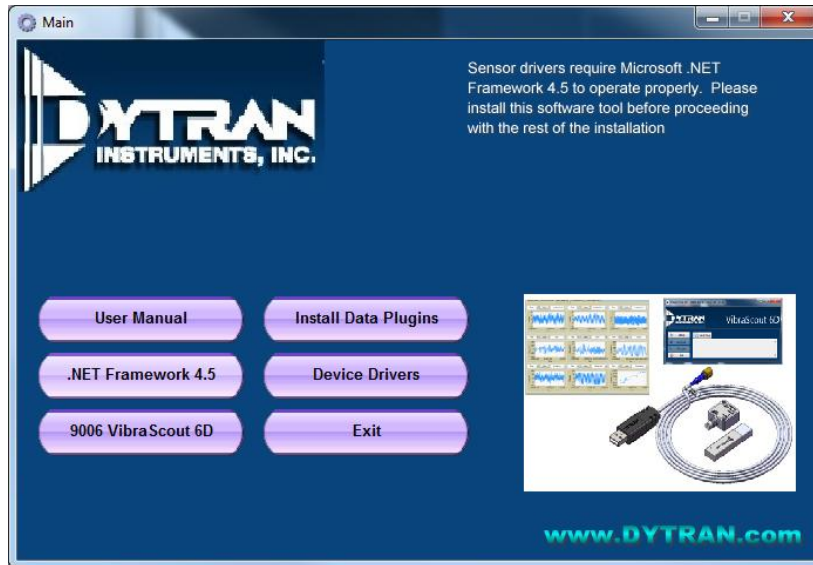

Figure 1: Autorun Menu

There are two additional installations that are required prior to installing the 9006 software. Install Data Plug-ins by clicking the button on the Autorun menu. This will install plug-ins for data export. Once completed, install the VibraScout 6D device drivers by pressing the Device Drivers button from the Autorun menu. Follow the on screen prompts keeping the default selections to install both software tools.

To install the runtime software, click on 9006 to start the installation of the 9006 VibraScout™ 6D software. Make sure that no other applications are open and proceed with the following steps.

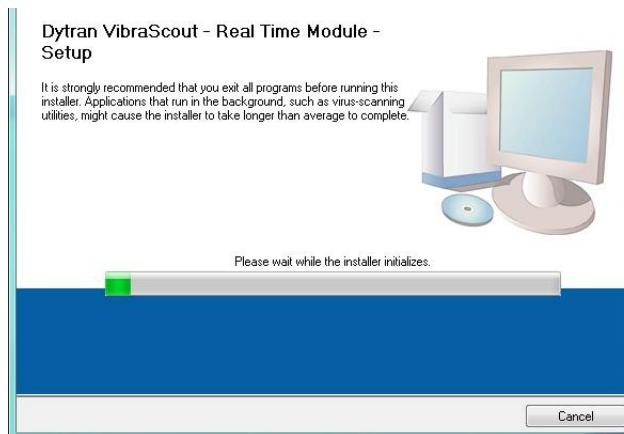

Figure 2: Installation Welcome Screen

1. When the installer initialization is completed, click on “Next”. In the following window, the user can define the directories in which the *Dytran VibraScout™ 6D* software and the National Instrument libraries will be saved. Click on “Browse” to select a different folder, and then click on “Next” to proceed.

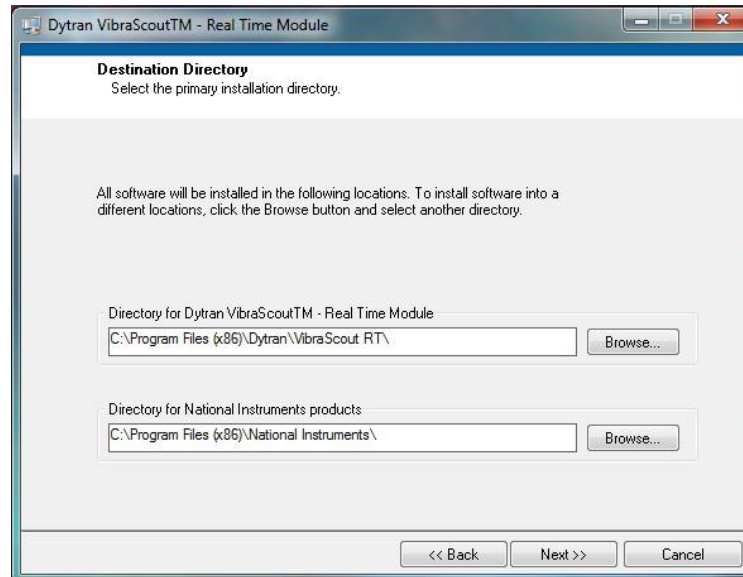

Figure 3: Install Destination Directory

2. In the next window, select “I accept the license agreement...” to accept *Dytran VibraScout™ 6D* license conditions and then click on “Next”.
3. Select “I accept the license agreement...” to accept *National Instrument* license conditions and then click on “Next”.
4. At this point, select “I accept 2 license agreement(s)...” to accept *Microsoft Silverlight 5 EULA* and *Microsoft Silverlight Privacy Statement* conditions. Click on “Next” to proceed.
5. The “Start Installation” window will appear. It indicates whether a component will be upgraded or installed for the first time. Click on “Next” to start the installation. This process may take a few minutes. Please wait until the installation is complete.
6. When the installation is complete, click on “Next” to proceed.
7. If asked, reboot your PC, clicking on “Restart” in the following window.



Figure 4: Restart after Installation Completed

VI. Operation

1. After the computer restart, the user will find the “9006 *VibraScout(6D)*” icon in the Windows menu, as shown in Figure 5 below. A Shortcut will also be created on the Desktop for ease of access.



Figure 5: VibraScout 6D Icon

2. Make sure the accelerometer is connected to the USB port and click on the icon to launch the software.
3. The following Control panel will appear as shown in Figure 6.

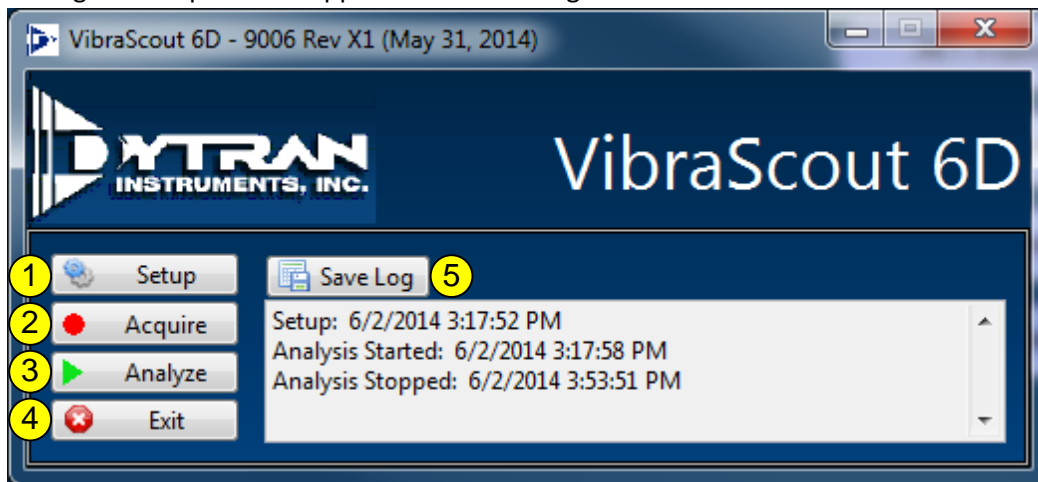

Figure 6:9006 Software Control Panel

- 3.1. Setup – This button will allow user to input setup parameters as shown in Figure 7.
 - 3.2. Acquire – User can start monitoring/recording by pressing this button.
 - 3.3. Analyze – After recording is completed, analysis tool can be displayed using this button. This will allow user to utilize post processor to export data in various formats.
 - 3.4. Exit – This button will exit the program.
 - 3.5. Save Log – All actions are logged in the navigation window below. Log is date and time stamped and can be exported to a text file at the end of the test.
4. Click on the “Setup” button to setup for a test. The Window in Figure 7 will display and user to define the following parameters as described in steps 4.1 to

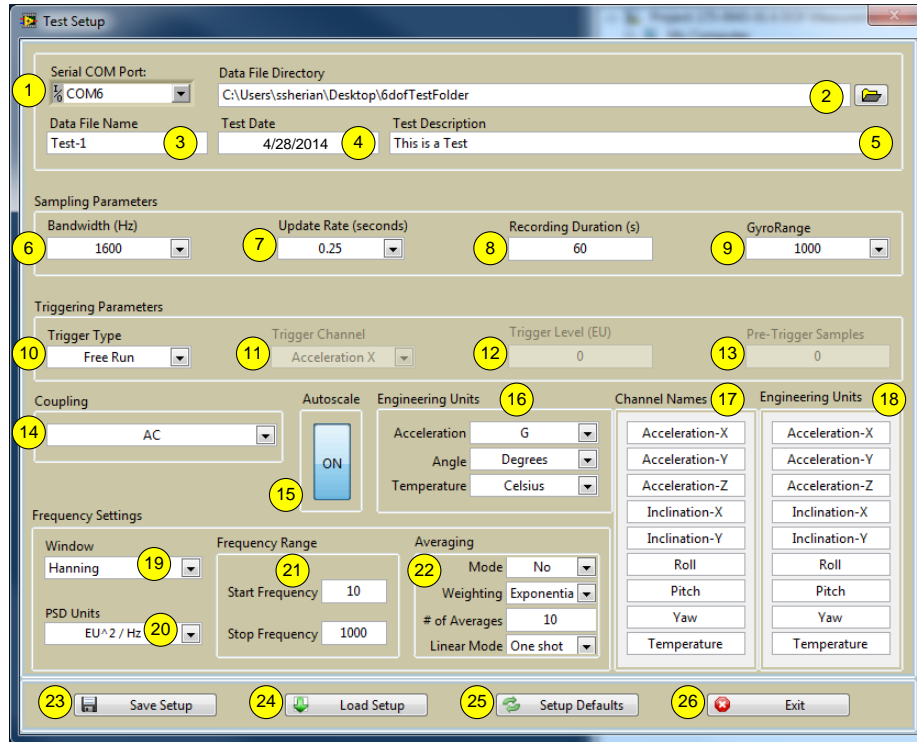

Figure 7: Test Setup Menu

- 4.1. Serial COM Port – USB sensor interfaces to computer via a USB to RS232 virtual COM port. Typically this field will only have a single COM port on modern computers. However, if there are more than a single COM port, navigate to the Device Manager from My Computer Properties and under Ports (COM & LPT) locate the port # for “USB Serial Port (COM#)” which indicates the port number for the USB sensor being used. On the Setup menu, select this port as your interface port # from the drop down list.
- 4.2. Data File Directory – This field allows user to select the folder in which data will be stored. All of the following files will be stored in the directory defined in this field.
Setup File with *.setup extension
Data File in the NI TDMS format (*.tdms)
- 4.3. Data File Name – This is the test title as well as the File name to be appended by date and time of creation for the setup file.
- 4.4. Test Date – This is automatically populated by the program when the setup file is first created.
- 4.5. Test Description – a single line description can be entered for the test in this field.
- 4.6. Bandwidth (Hz) – This field sets the maximum bandwidth for the data acquired from the sensor. The following parameters are valid for this field.
 - 4.6.1. Sampling Frequency (F_s) = 2 x Bandwidth (BW)
 - 4.6.2. Maximum Sampling rate for accelerometer (all three channels) = 3200Hz
 - 4.6.3. Maximum Sampling rate for gyro (all three channels) = 2000Hz
 - 4.6.4. When BW is set to 1600Hz (This will set accelerometer F_s = 3200Hz), software will automatically set gyro sampling rate to F_s = 1600 Hz. In other words, at maximum bandwidth of 1600Hz, the true bandwidth of the accelerometer is 1600Hz but the gyro

- bandwidth is limited to 2000Hz. At all other bandwidth settings, the accelerometer and gyro bandwidth and sampling rates are equal.
- 4.6.5. Temperature sampling rate = 1 sample/frame of data acquired.
 - 4.6.6. Inclination x and y data is sampled at the same rate as the accelerometer data rate.
 - 4.7. Update Rate (seconds) – this is the rate at which plots are updated. For slower CPUs, increasing the update rate (0.5s or 1s) may help improve performance.
 - 4.8. Recording Duration (s) – this field defines the length of recording of the real time software. Real time software will compare elapsed time to this field and determine whether to stop recording or continue. This field is only read when software is in recording mode and will be ignored for monitor mode.
 - 4.9. Gyro Range – This defines the full scale range of the Gyro sensor.
 - 4.10. Trigger Type – Software can run the acquisition in 3 different triggering modes. Free Run will start recording software once Record is pressed. Over/Under threshold will only start recording once data exceeds the pre-defined threshold value either above or below respectively based on selected type. (Both triggering and free run modes use the same (4.8) value to stop recording.)
 - 4.11. Trigger Channel – This will allow user to select the triggering channel. User can select any individual channel and the triggering will evaluate the engineering units of the acquired data of the specified channel to start recording. User can also select all acceleration channels or all gyro channels to start triggering if any of the 3 channel values exceeds the threshold value in engineering units.
 - 4.12. Trigger Level (EU) – This is the trigger level for the selected channel in 4.11 at which recording will start. This field is defined in engineering units as selected in section 4.16.
 - 4.13. Pre-Trigger Samples – Defines the # of samples to acquire prior to trigger threshold level. This will ensure that no samples are lost prior to the trigger occurrence.
 - 4.14. Coupling – Sensor is by default DC coupled. To remove DC components, user can select AC coupling.
 - 4.15. Autoscale – will enable auto scaling on all the plots in the real time software.
 - 4.16. Engineering Units – there are 3 different sensing elements in the 7546A sensors. The default engineering units are G for acceleration, degrees for angle, and Celsius for temperature.

Other acceleration units are m/s^2

Other angular units are radians

Temperature units can be displayed in Fahrenheit, Kelvin or Rankine.



Presented by: Absolute Gauge Technologies
sales@absolute-gauge.com; www.absolute-gauge.com,
Toronto: 416 754 3168, Montreal: 514 695 5147, Toll Free: 1 888 754 7008



- 4.17. Channel Names – These fields are automatically populated by software with proper channel names.
- 4.18. Engineering Units – reflect the engineering units for each channel based on selection from 4.16.
- 4.19. Window – for frequency data display purposes only, this windowing can be applied to all FFT and PSD data in the real time software.
- 4.20. PSD Units – This field only affects PSD plots. Y-axis of PSD plots can be displayed either in EU/sqrt(Hz) or EU²/Hz units.
- 4.21. Frequency Range – for FFT and PSD plots, the minimum and maximum frequency of the X-axis can be set using this field.
- 4.22. Averaging – Frequency averaging parameters can be set using this group of controls.
- 4.23. Save Setup – user can choose to save the current setup to a binary file.
- 4.24. Load Setup – a previously saved setup file *.setup can be loaded into software using this control.
- 4.25. Setup Defaults – this button will reset all fields on the setup menu to the default values. If the default is blank, this will re-initialize all blank fields.
- 4.26. Exit – to exit setup after proper parameters have been saved.



Presented by: Absolute Gauge Technologies
sales@absolute-gauge.com; www.absolute-gauge.com,
Toronto: 416 754 3168, Montreal: 514 695 5147, Toll Free: 1 888 754 7008

- Once completed with Setup, from Figure 6, click on the Acquire button to start real time acquisition.

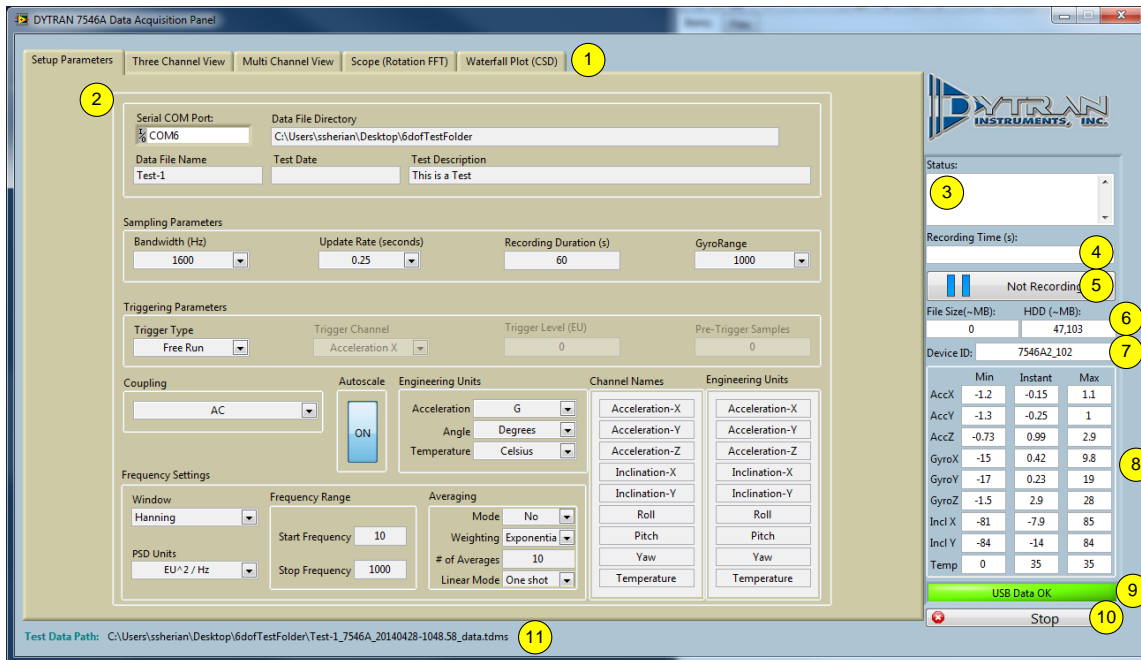

Figure 8: Real Time Software

- 5.1. Tabs – user can navigate through these tabs to display different types of plots or the setup parameters from the setup menu.
- 5.2. Setup Parameters – displays the setup parameters as configured in the setup menu.
- 5.3. Status – will display any status updates of the current session. Buffer overflow, sensor errors, recording indications will display in this field when events occur.
- 5.4. Recording Time – displays the current recording elapsed time in days_hours: minutes: seconds.
- 5.5. Not Recording/Recording – this will enable/disable recording sessions. Every time the recording button is pressed, a new data file is generated with date and time of recording.
- 5.6. File Size (~MB), HDD (~MB) – these fields display the current file size in megabytes and the available hard disk space in megabytes.
- 5.7. Device ID – displays the model and serial number of the connected device.
- 5.8. Min, Instant, Max – displays the minimum, instant, and maximum values in engineering units of the 9 channels for the overall recording duration.

- 5.9. USB Data OK – this indicator will update the status of the USB sensor error status. If no errors occur, the data is OK. If buffer overflow or checksum error occurs, this indicator will turn red and display the corresponding error.
- 5.10. Stop – stops the acquisition software and closes the window. The Control panel will be displayed.
- 5.11. Test Data Path – displays the folder path where recorded data is stored.

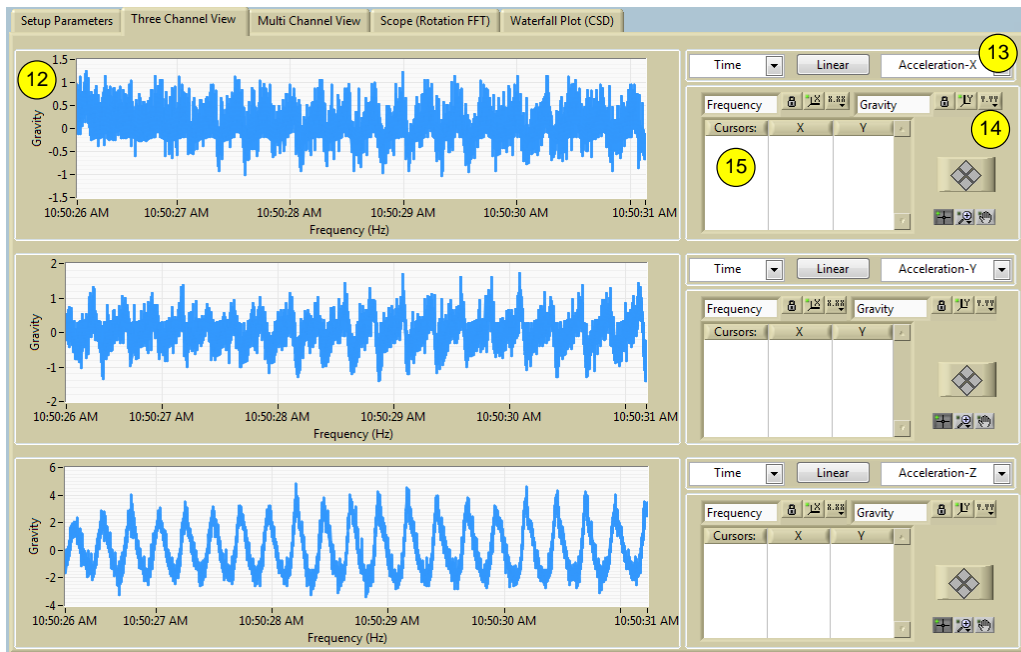

Figure 9: Three Channel View

- 5.12. Three Channel View tab displays time and frequency data in 3 different plots. All plots and properties are identical to one another and each plot can display any user selectable channel either in time domain or frequency domain.
- 5.13. Controls – allow user to select channel to be displayed on the plot in either Time domain or frequency domain (FFT or PSD); plot Y-axis can be scaled either linear or logarithmic.
- 5.14. Scale Legend – provides user quick access to x and y axis scaling parameters. Parameters include format, precision, mapping, etc.
- 5.15. Cursor Legend – user has the option to add as many cursors as desired. Cursors can be created by right clicking inside this field and selecting create cursor.

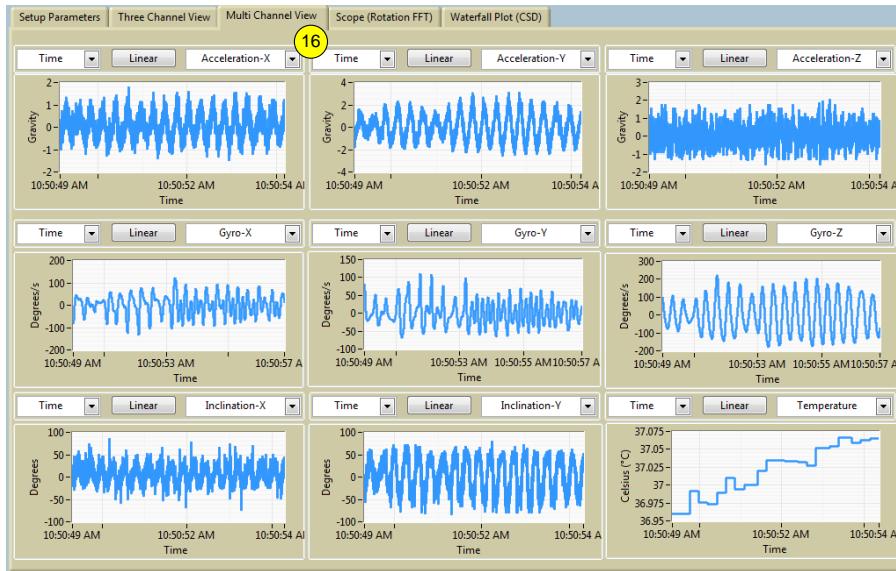

Figure 10: Multi Channel View

- 5.16. Multi Channel View – displays all 9 channels of data on a single window. Each channel has its plot display with selection options between time or frequency domain data. Scaling and channel selection controls are similar to that in the previous tab.

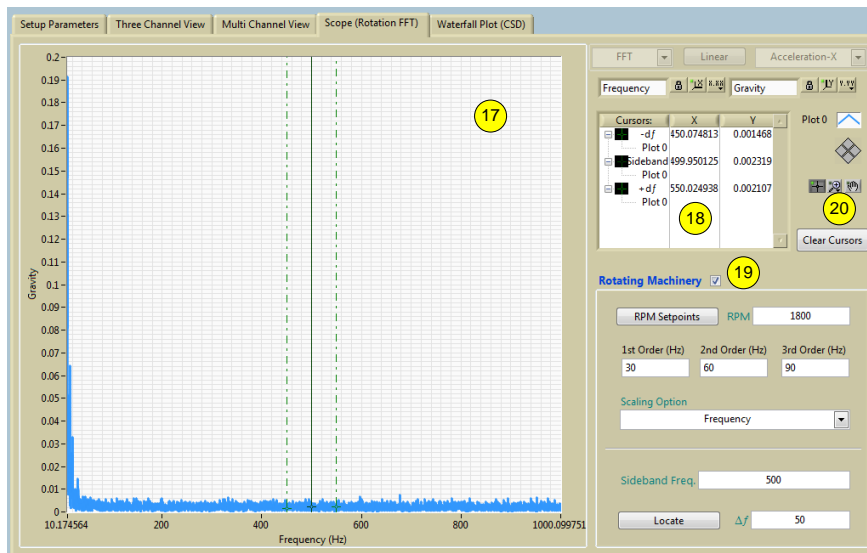

Figure 11: Scope (Rotation FFT)

- 5.17. Scope(Rotation FFT) – displays a single plot of user selected channel. Plot can display either time or frequency data. In frequency domain, rotating machinery analysis is possible.
- 5.18. Cursor List – includes a list of populated cursors based on rotating machinery analysis parameters. Cursors populated include the fundamental frequency based on RPM input, 2nd and 3rd order

harmonics of fundamental frequency. Also cursors are placed on side band frequencies based on frequency input.

5.19. Rotating Machinery – This enables the rotating machinery analysis tab which includes the following parameters:

- 5.19.1. RPM Set points – enables positioning of the cursors at 1st, 2nd, and 3rd order frequencies based on RPM input.
- 5.19.2. RPM – provides user a field to input RPM value to be analyzed.
- 5.19.3. 1st Order (Hz) – based on RPM input first order frequency is calculated by the following formula: 1st order Hz = RPM / 60.
- 5.19.4. 2nd order (Hz) – based on RPM input second order frequency is calculated by the following formula: 2nd order Hz = 2*RPM / 60.
- 5.19.5. 3rd order (Hz) – based on RPM input second order frequency is calculated by the following formula: 3rd order Hz = 3*RPM / 60.
- 5.19.6. Scaling Option – allows user to select the x-axis scaling from frequency, order, or RPM values.
- 5.19.7. Sideband Frequency – provides user to input a frequency to perform sideband analysis
- 5.19.8. Delta f – provides the sideband bandwidth in Hz.
- 5.19.9. Locate – automatically places the cursors from the pre-defined sideband and RPM analysis fields.

5.20. Clear Cursors – clears all preset cursors from cursor legend and graph display.

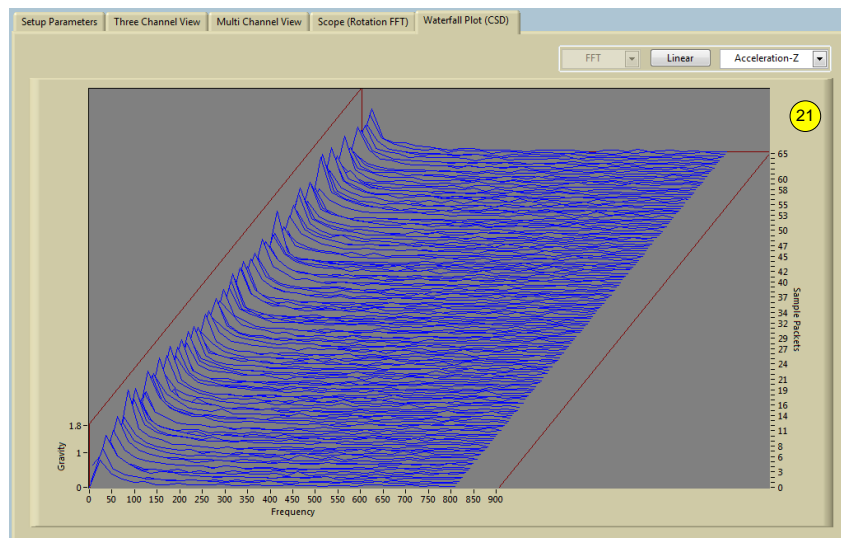
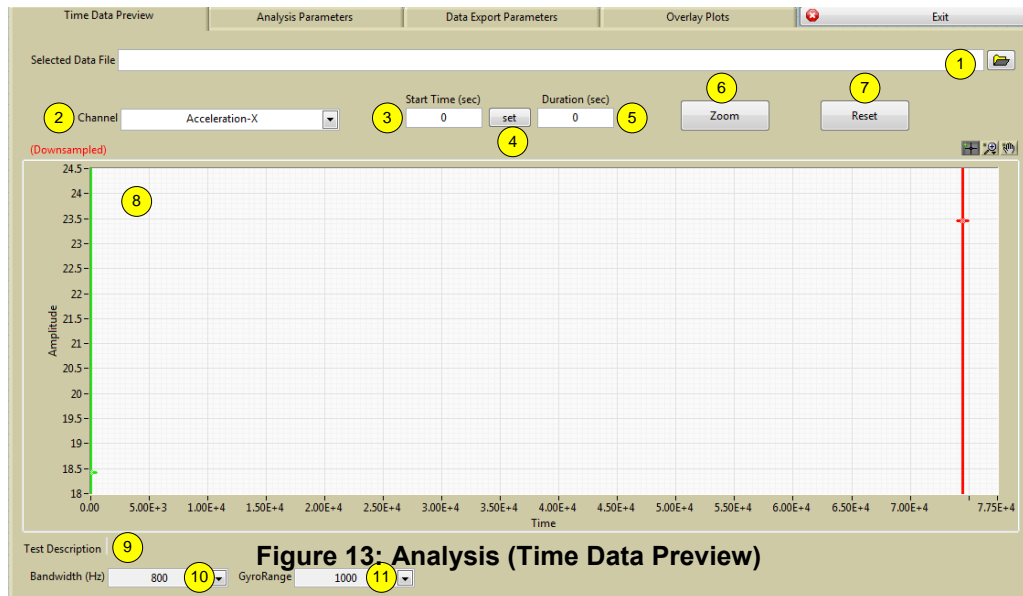

Figure 12: Waterfall Plot (CSD)

5.21. Waterfall Plot (CSD) – displays the waterfall plot of FFT data from the 5 second buffered time data. User can select channel to be displayed as well as scaling of Y-axis.

6. To access the post processor software, on the main control panel press the Analysis button and a window similar to Figure 13 will be displayed.



6.1. Selected Data File – displays the recorded data file name and path to be analyzed. (The file directory is also the starting path where the exported data will be saved to.)

6.2. Channel – allows user to select channel to view for selecting analysis window.

6.3. Start Time (sec) – User can instead of setting the cursor for start time select to type in the value in seconds and cursor will automatically be set to start position on the x-axis.

6.4. Set – Once starting time and duration are inputted, pressing this button will set the cursors at the desired values.

6.5. Duration (sec) – allows user to enter the analysis duration in seconds from starting point.

6.6. Zoom – allows user to zoom in on the dataset being analyzed and set by the red and green cursors. User is to set cursors at desired start and end positions or input values in the start and duration fields and press Zoom to view selected data only.

6.7. Reset – if selected zoom window is not the correct window, user can reset data to display all recorded samples and start over by pressing the Reset button.

- 6.8. Plot – displays the recorded data for the selected channel. The red and green cursors are to set the start and end locations of the data to be analyzed.
- 6.9. Test Description – this is a quick indication of the test description as saved in the recorded file.
- 6.10. Sampling Rate(Hz) – displays the sampling rate at which the selected channel was acquired.
- 6.11. GyroRange – specifies the range at which gyro data was acquired.

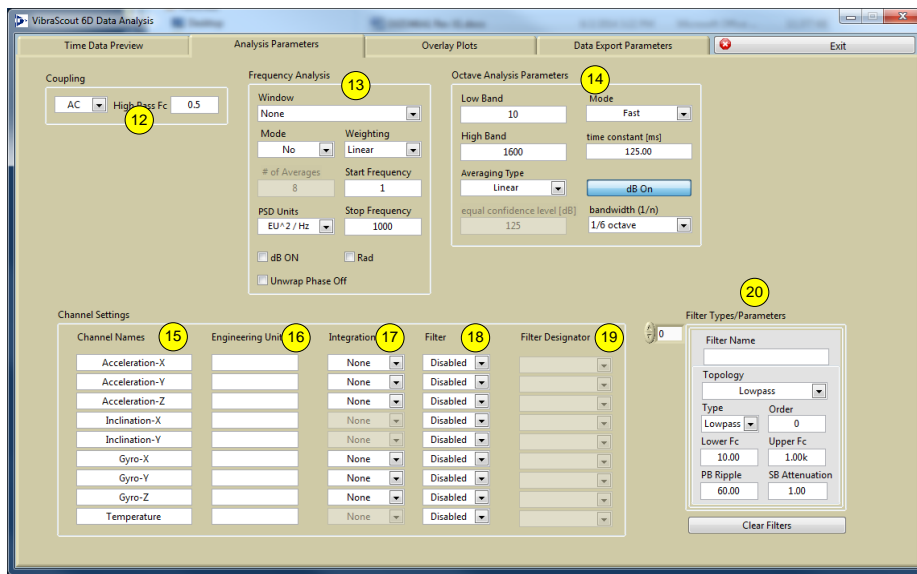

Figure 14: Analysis Parameters

- 6.12. Coupling – user has the option to apply an AC coupling high pass filter at a defined corner frequency to the data to be analyzed.
- 6.13. Frequency Analysis – user can set frequency analysis parameters for the FFT and PSD data. Windowing, averaging mode and PSD units as well as y-axis scaling parameters can be set through this field.
- 6.14. Octave Analysis (CPB) – user can set octave analysis parameters to the data being analyzed.
- 6.15. Channel Names – these channel names are acquired from the recorded data and are not modifiable.
- 6.16. Engineering Units – are units acquired from the recorded data file and are only modifiable via the integration fields. Units will change to reflect the type of integration applied.

- 6.17. Integration – user can choose to apply single or double integration to appropriate channels. If acceleration is integrated once, velocity information can be obtained. If it is integrated twice, displacement information can be obtained. As for gyro, a single integration on gyro will return angular displacement.
- 6.18. Filter – user can choose to apply individual filters to any channel. If this field is enabled, a filter selected from 13.19 will be applied to the corresponding channel.
- 6.19. Filter Designator – these fields will be populated by the types of filters setup from the Filter Types/Parameters field 13.20.
- 6.20. Filter Types/Parameters – Multiple filters can be setup and applied to any channel. (Only one filter can be applied to any single channel at a time.) Once these filters are created, the filter names will automatically be populated in the Filter Designator fields (6.19).

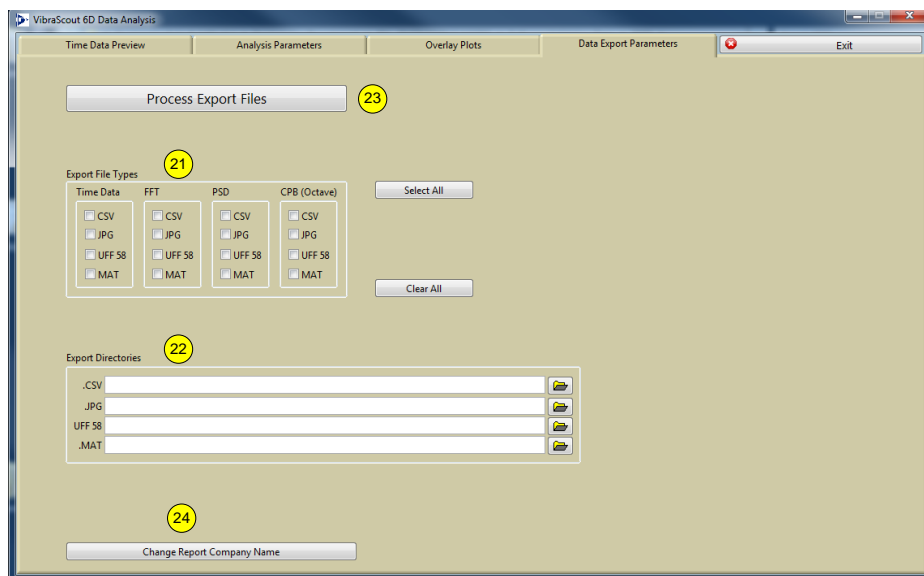

Figure 15: Data Export Parameters

- 6.21. Export File Types – user can select file types for all data generated whether Time, FFT, PSD, or CPB data. (The UFF58 file for Time Data will be limited by the amount of system memory available; whereas the .csv and .mat file will reflect the selected data between the cursors selected in section 6.6.)
- 6.22. Export Data Directory – is the default directory where all data will be exported. User can choose to modify directory location for any *type* of exported file.
- 6.23. Process – Once all export parameters are setup, pressing the Process button will generate all the data and plots selected by the user and store them in the proper directories as selected.

- 6.24. Reports generated by post processor are exported with a pre-formatted template that bears the company name. This company name can be modified/updated by pressing this button and typing the company name. Once name is updated, press save to update the field with the desired value.

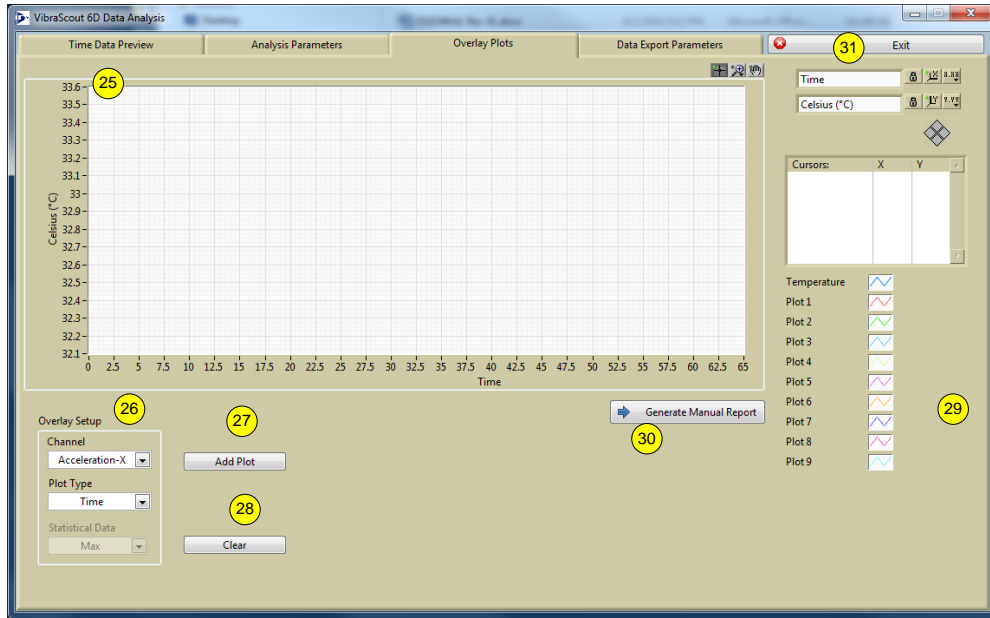

Figure 16: Overlay Plots

- 6.25. Plot Overlay – this graph displays channel graphs to be overlaid. Various types of graphs can be overlaid in this field, as defined by section 6.28.
- 6.26. Overlay Setup – user can select individual channels to overlay onto the plot. The plot type for all channels overlaid will be the same. For example, if X-axis acceleration time history channel was used as the first plot, all consecutive plots will also be in the time domain. For statistical data types, the desired statistical data can be selected from the drop down menu.
- 6.27. Add Plot – once desired channel and plot type are selected, user can press Add Plot to add the channel data onto the graph.
- 6.28. Clear – this will clear all data in the plot display (6.25).
- 6.29. Plot Legend – Each channel/data type added to the graph will create a separate channel and will be displayed next to the data line color indicator.
- 6.30. Generate Manual Report – once channel data is added to the overlay graph, the user can export a screenshot of the overlaid graph to a report file (only works for the first channel).



6.31. Exit – once analysis is completed press this button to exit the post processor.

VII. Custom Applications

An API is available for customers who would like to build custom applications for the 7546A. The API provides support for any .NET-compatible client application - e.g. LabView, C#, etc. Please contact Dytran at sales@dytran.com or **818-700-7818**.

Custom application development is also available.

Please contact Dytran at dchange@dytran.com or **818-700-7818** for more information.



Presented by: Absolute Gauge Technologies
sales@absolute-gauge.com; www.absolute-gauge.com,
Toronto: 416 754 3168, Montreal: 514 695 5147, Toll Free: 1 888 754 7008



VIII. Software License, Restrictions, and Disclaimer

LICENSE: The Dytran Instruments, Inc. (Dytran) VibraScout™ software application (the Software) available for download via the Dytran website, via email, or made available on portable storage devices shipped with Dytran products is a free license for Dytran customers to use with Dytran products. Dytran encourages you to know the possible risks involved in the download and use of Software from the Internet. You are solely responsible for protecting yourself, your data, your systems and your hardware used in connection with the Software. Dytran will not be liable for any damages suffered from the use of the Software.

RESTRICTIONS: Neither the Software Licensee nor any Licensed User may rent or lease the Software. Neither the Software Licensee nor any Licensed User may modify, reverse engineer, decompile or disassemble the Software.

DISCLAIMER: BY USING THE SOFTWARE, YOU EXPRESSLY AGREE THAT ALL RISKS ASSOCIATED WITH THE PERFORMANCE AND QUALITY OF THE SOFTWARE IS ASSUMED SOLELY BY YOU. DYTRAN SHALL NOT BE LIABLE FOR ANY DIRECT, INDIRECT, INCIDENTAL, SPECIAL OR CONSEQUENTIAL DAMAGES ARISING OUT OF THE USE OF OR INABILITY TO USE THE SOFTWARE, EVEN IF DYTRAN HAS BEEN ADVISED OF THE POSSIBILITY OF SUCH DAMAGES.

THE SOFTWARE IS MADE AVAILABLE BY DYTRAN "AS IS" AND "WITH ALL FAULTS". DYTRAN DOES NOT MAKE ANY REPRESENTATIONS OR WARRANTIES OF ANY KIND, EITHER EXPRESS OR IMPLIED, CONCERNING THE QUALITY, SAFETY OR SUITABILITY OF THE SOFTWARE; INCLUDING WITHOUT LIMITATION ANY IMPLIED WARRANTIES OF MERCHANTABILITY, FITNESS FOR A PARTICULAR PURPOSE, OR NON-INFRINGEMENT. IN NO EVENT WILL DYTRAN BE LIABLE FOR ANY INDIRECT, PUNITIVE, SPECIAL, INCIDENTAL OR CONSEQUENTIAL DAMAGES THROUGH THE USE OF THE SOFTWARE HOWEVER THEY MAY ARISE AND EVEN IF DYTRAN HAS BEEN PREVIOUSLY ADVISED OF THE POSSIBILITY OF SUCH DAMAGES.



Presented by: Absolute Gauge Technologies
sales@absolute-gauge.com; www.absolute-gauge.com,
Toronto: 416 754 3168, Montreal: 514 695 5147, Toll Free: 1 888 754 7008