

# Digital I/O board, optically isolated, 32 digital inputs and outputs, 24 V / 12 V

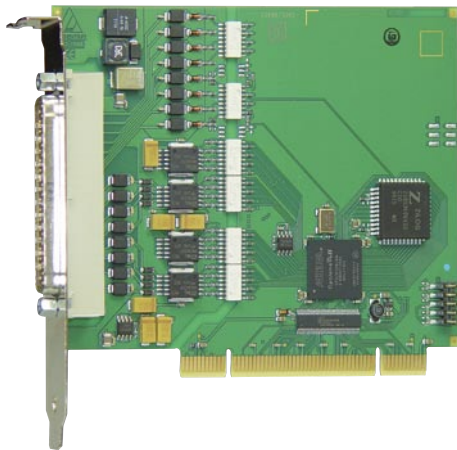

**PCI** 32-bit

**Also for CompactPCI™**  
See CPCI-1500,  
page 176

**Also for PC/104-PLUS**  
See page 172

**Also for**  
**PCI EXPRESS®** see  
page 78



Signed 64-bit drivers  
for Windows 7/Vista/XP



LabVIEW™



LabWindows/CVI™

**DASYLab10**  
Data Acquisition System Laboratory



## Features

- 3 programmable timers
- Connector compatible to the ISA board PA 1500. Connector and software compatible to the digital I/O boards APCLe-1532 for the PCI Express bus and CPCI-1500 for the CompactPCI bus.
- Monitoring program for testing and setting the board functions

## Inputs

- 16 optically isolated digital inputs, 24 V or 12 V (APCI-1500-12V), including 14 interruptible inputs
- Reverse voltage protection
- All inputs are filtered

## Outputs

- 16 optically isolated digital outputs, 10 V to 36 V
- Output current per channel 500 mA
- Timer programmable watchdog for resetting the outputs to „0“
- Diagnostic report through status register at short-circuits, overtemperature, voltage drop or watchdog
- Interrupt triggered through watchdog, timer, error
- At Power-On, reset of the outputs to „0“
- Short-circuit current for 16 outputs ~ 3 A typ.
- Short-circuit current per output ~1.5 A typ.
- Self-resetting fuse (electronic fuse)
- Overtemperature and overvoltage protection
- 24 V power outputs with protection diodes and filters
- Output capacitors against electromagnetic emissions
- External 24 V voltage supply screened and filtered
- Shutdown logic, when the external supply voltage drops below 5 V

## Safety features

- Optical isolation 1000 V
- Creeping distance IEC 61010-1
- Protection against fast transients (burst), overvoltage, electrostatic discharge and high-frequency EMI
- Separate ground lines for inputs and outputs

## APCI-1500 / APCI-1500-12V

16 digital inputs, 24 V or 12 V,  
including 14 interruptible inputs

16 digital outputs, 10-36 V, 500 mA/channel

Optical isolation 1000 V

Input and output filters

Watchdog, timer

At Power-On the outputs are reset to “0”

## Applications

- Industrial I/O control
- PLC coupling
- Reading of encoder values for process control
- Signal switching
- Interface to electromechanical relays
- ON/OFF monitoring of motors, lights...
- Watchdog / Timer
- Machine interfacing, ....

## Software drivers

A CD-ROM with the following software and programming samples is supplied with the board.

### Standard drivers for:

- Linux
- 32-bit drivers for Windows 8 / 7 / Vista / XP / 2000
- Signed 64-bit drivers for Windows 8 / 7 / XP
- Real-time use with Linux and Windows on request
- RTX drivers (real-time)

### Drivers and samples for the following compilers and software packages:

- Microsoft VC++ • Microsoft C
- Borland C++ • Borland C
- Visual Basic • Delphi
- .NET on request
- LabVIEW • LabWindows/CVI • DASYLab • DIAdem

### On request:

Further operating systems, compilers and samples.

Driver download: [www.addi-data.com/downloads](http://www.addi-data.com/downloads)

## Specifications

### Digital inputs

|                                 |   |
|---------------------------------|---|
| Number of inputs:               | 16 (common ground acc. to IEC 1131-2)               |
| Including interruptible inputs: | 14, IRQ line selected through BIOS                  |
| Optical isolation:              | Through opto-couplers, 1000 V from PC to peripheral |
| Compare logic:                  | AND and OR mode; OR priority                        |

### 24 V version (APCI-1500)

|                          |                            |
|--------------------------|----------------------------|
| Nominal voltage:         | 24 V                       |
| Input current at 24 V:   | 6 mA typ.                  |
| Logic input levels:      | U nominal: 24 V            |
| UH max.:                 | 30 V/current 9 mA typ.     |
| UH min.:                 | 19 V/current 2 mA typ.     |
| UL max.:                 | 14 V/current 0.7 mA typ.   |
| UL min.:                 | 0 V/current 0 mA typ.      |
| Signal delay:            | 70 µs (at nominal voltage) |
| Maximum input frequency: | 5 kHz (at nominal voltage) |

### 12 V version (APCI-1500-12V)

|                          |                            |
|--------------------------|----------------------------|
| Nominal voltage:         | 12 V                       |
| Input current at 12 V:   | 4.2 mA typ.                |
| Logic input levels:      | U nominal: 12 V            |
| UH max.:                 | 16 V/current 6.3 mA typ.   |
| UH min.:                 | 9 V/current 2.7 mA typ.    |
| UL max.:                 | 6 V/current 1.2 mA typ.    |
| UL min.:                 | 0 V/current 0 mA typ.      |
| Signal delay:            | 70 µs (at nominal voltage) |
| Maximum input frequency: | 5 kHz (at nominal voltage) |

### Digital outputs

|  |   |
|--|---|
| Number of outputs:   | 16, optically isolated up to 1000 V through opto-couplers |
| Output type:   | High-side (load to ground) acc. to IEC 1131-2             |
| Nominal voltage:   | 24 V / 12 V (APCI-1500-12V)                               |
| Supply voltage:  | 10 V to 36 V, min. 5 V (via front connector)              |
| Max. current for 16 outputs:   | 3 A typ.  |
| Output current/output:   | 500 mA max.   |
| Short-circuit current/output shutdown at 24 V, $R_{load} < 0.1 \Omega$ : | 1.5 A   |
| RDS ON resistance:   | 0.4 Ω max.  |
| Switch-on time:  | $I_{out}=0.5 A$ , load = resistance: 100 µs               |
| Switch-off time:   | $I_{out}=0.5 A$ , load = resistance: 60 µs                |
| Overtemperature (shutdown):  | 170 °C (output driver)                                    |
| Temperature hysteresis:  | 20 °C (output driver)                                     |

### Safety

|                 |  |
|-----------------|--|
| Shutdown logic: | When the ext. 24 V voltage drops below 5 V:<br>The outputs are switched off. |
| Diagnostics:    | Status bit or interrupt to the PC  |
| Timer:          | 3  |
| Watchdog:       | Timer-programmable, 10 µs to 37 s  |

### EMC – Electromagnetic compatibility

The product complies with the European EMC directive. The tests were carried out by a certified EMC laboratory in accordance with the norm from the EN 61326 series (IEC 61326). The limit values as set out by the European EMC directive for an industrial environment are complied with. The respective EMC test report is available on request.

### Physical and environmental conditions

|                      |   |
|----------------------|---|
| Dimensions:          | 131 x 99 mm   |
| System bus:          | PCI 32-bit 3.3/5 V acc. to specification 2.1 (PCISIG) |
| Space required:      | 1 PCI slot  |
| Operating voltage:   | +5 V, ± 5 % from the PC                               |
| Current consumption: | 400 mA typ. ± 10 %                                    |
| Front connector:     | 37-pin D-Sub male connector                           |
| Temperature range:   | 0 to 60 °C (with forced cooling)                      |

### Simplified block diagram

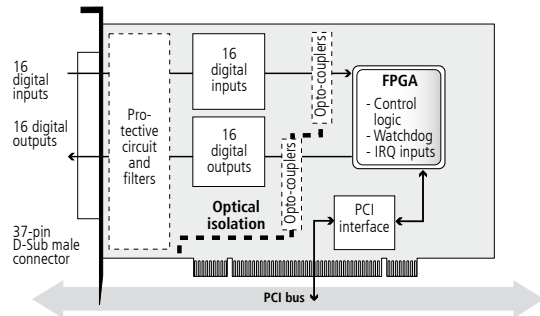

### Pin assignment – 37-pin D-Sub male connector

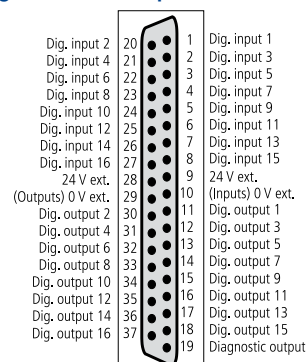

### ADDI-DATA connection

#### Example 1

Connection of the inputs and outputs through screw terminal panels

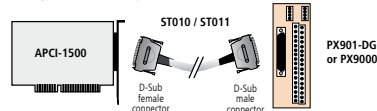

#### Example 2

- Connection of the inputs through screw terminal panel PX901-DG  
- Connection of the outputs through relay output board PX8500-G cascaded in 16 relays

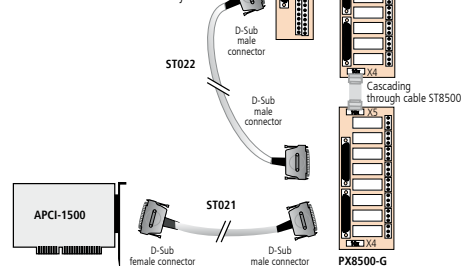

### Ordering information

#### APCI-1500 / APCI-1500-12V

Digital I/O board, optically isolated, 32 digital inputs and outputs, 24 V / 12 V. Incl. technical description, software drivers and monitoring program.

#### Versions

|                       |  |
|-----------------------|--|
| <b>APCI-1500:</b>     | Digital I/O board, opt. isolated, 32 dig. I/O, 24 V inputs, outputs 10 to 36 V |
| <b>APCI-1500-12V:</b> | Digital I/O board, opt. isolated, 32 dig. I/O, 12 V inputs, outputs 10 to 36 V |

#### Accessories

|                  |  |
|------------------|--|
| <b>PX901-D:</b>  | Screw terminal panel, LED status display               |
| <b>PX901-DG:</b> | Screw terminal panel, LED status display, for DIN rail |

|                  |  |
|------------------|--|
| <b>PX9000:</b>   | 3-row screw terminal panel for DIN rail, LED status display              |
| <b>PX8500-G:</b> | Relay output board for DIN rail, cascadable                              |
| <b>ST010:</b>    | Standard round cable, shielded, twisted pairs, 2 m                       |
| <b>ST011:</b>    | Standard round cable, shielded, twisted pairs, 5 m                       |
| <b>ST010-S:</b>  | Same as ST010, for high currents (separate 24 V supply)                  |
| <b>ST021:</b>    | Round cable between APCI-1500 and PX8500-G, shielded, twisted pairs, 2 m |
| <b>ST022:</b>    | Cable between PX8500-G and PX901-DG, shielded, 2 m                       |
| <b>ST8500:</b>   | Ribbon cable for cascading two PX 8500                                   |