

MV-CU013-A0GM/GC

1.3 MP 1/2" CMOS GigE Area Scan Camera



GEN*<i>i>*CAM

GigE
VISION

Introduction

MV-CU013-A0GM/GC camera provides high-quality images. It uses GigE interface to transmit non-compressed images in real time, and its max. frame rate can reach 91.3 fps in full resolution.

Key Feature

- Adopts low consumption design with stable performance.
- Supports auto or manual adjustment of gain, exposure time, and manual adjustment of LUT, Gamma correction, etc.
- Supports hardware trigger, software trigger, free run, etc.
- Adopts GigE interface and max. transmission distance of 100 meters without relay.
- Compatible with GigE Vision V2.0 Protocol, GenICam Standard, and third-party software based on the protocol and standard.

Available Model

- Mono camera: MV-CU013-A0GM
- Color camera: MV-CU013-A0GC

Applicable Industry

Electronics and semiconductor, factory automation, logistics and code reading, medicine package, etc.

Sensor Quantum Efficiency

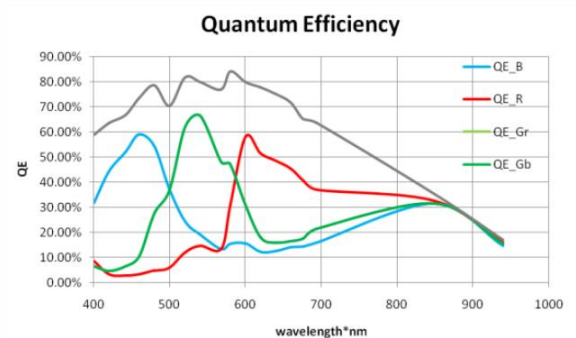

Dimension

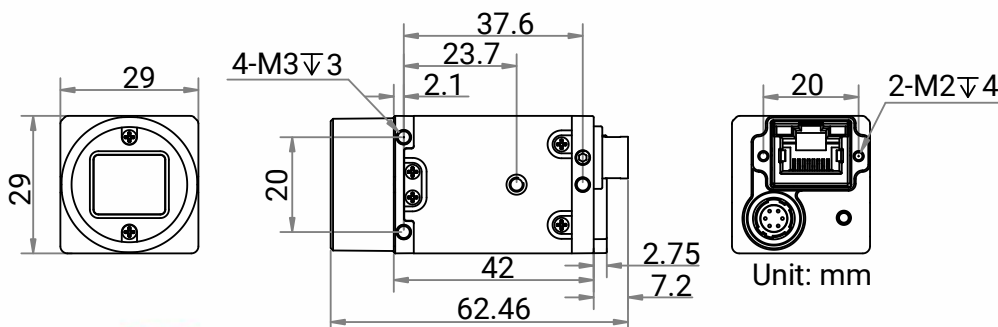

Specification

Model	MV-CU013-A0GM	MV-CU013-A0GC
Performance		
Sensor type	CMOS, global shutter	
Pixel size	4.8 μm \times 4.8 μm	
Sensor size	1/2"	
Resolution	1280 \times 1024	
Max. frame rate	91.3 fps@1280 \times 1024 Mono 8	91.3 fps@1280 \times 1024 Bayer GB 8
Dynamic range	54 dB	
SNR	40.6 dB	
Gain	0 dB to 16 dB	
Exposure time	10 μs to 10 sec	
Exposure mode	Off/Once/Continuous exposure mode	
Mono/color	Mono	Color
Pixel format	Mono 8/10/10Packed/12/12Packed	Bayer GB 8/10/10Packed/12/12Packed
Binning	Supports 1 \times 1, 2 \times 2, 4 \times 4	
Decimation	Supports 1 \times 1, 2 \times 2, 4 \times 4	
Reverse image	Supports horizontal and vertical reverse image output	
Electrical features		
Data interface	Gigabit Ethernet, compatible with Fast Ethernet	
Digital I/O	6-pin P7 connector provides power and I/O, including opto-isolated input \times 1 (Line 0), opto-isolated output \times 1 (Line 1), bi-directional non-isolated I/O \times 1 (Line 2).	
Power supply	9 VDC to 24 VDC, PoE is optional	
Power consumption	Typ. 1.8 W@12 VDC	
Mechanical		
Lens mount	C-mount	
Dimension	29 mm \times 29 mm \times 42 mm (1.1" \times 1.1" \times 1.7")	
Weight	Approx. 100 g (0.2 lb.)	
Ingress protection	IP30 (under proper lens installation and wiring)	
Temperature	Working temperature: 0 $^{\circ}\text{C}$ to 50 $^{\circ}\text{C}$ (32 $^{\circ}\text{F}$ to 122 $^{\circ}\text{F}$) Storage temperature: -30 $^{\circ}\text{C}$ to 70 $^{\circ}\text{C}$ (-22 $^{\circ}\text{F}$ to 158 $^{\circ}\text{F}$)	
Humidity	20% to 95% RH, non-condensing	
General		
Client software	MVS or third-party software meeting with GigE Vision Protocol	
Operating system	32/64-bit Windows XP/7/10, 32/64-bit Linux and 64-bit MacOS	
Compatibility	GigE Vision V2.0, GenICam	
Certification	CE, RoHS, KC	

HIKROBOT

Hangzhou Hikrobot Co., Ltd.
 en.hikrobotics.com

© Hangzhou Hikrobot Co., Ltd. All Rights Reserved.

Hangzhou Hikrobot does not tolerate any infringement. Any organization or individual may not imitate or reproduce in whole or in part of the content. The data herein is based on Hikrobot's internal evaluation. Actual data may vary depending on specific configuration and operating condition. The information herein is subject to change without notice. All the content has been checked conscientiously. Nevertheless, Hikrobot shall not be liable to damages resulting from errors, inconsistencies or omissions.