

Example: Toggle press

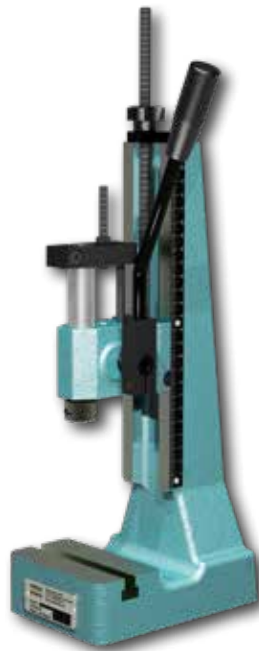

Example: Rack and pinion press



Example: Height-adjustable press head

Capacity range: from 500 N to 30 kN

Manual presses provide great economy for production processes and batch sizes which require no automation. They can be used quickly and flexibly in such applications.

mäder produces two types of hand-operated press with different force characteristics: toggle presses and rack and pinion presses. Almost all mäder hand-operated presses can be provided with round or square rams.

The diagram shows the differing force characteristics of the two systems with a constantly acting manual force on the lever.

- ▶ With toggle presses, the force characteristic rises exponentially to the end of the stroke. The nominal force of the press is therefore not attained until just before bottom dead centre is reached.
- ▶ Rack and pinion presses, by contrast, have a constant force characteristic over the entire stroke. The press force in this type of press is in direct relation to the manual force applied.

Quality features

- ▶ Simple and rapid adjustment of the height of the press head using a threaded spindle
- ▶ Hardened and ground ram
- ▶ Long, honed and therefore high-precision round ram guide
- ▶ High-accuracy square ram guide by means of adjustable jib strips
- ▶ Ground press table
- ▶ **mäder** manual presses are virtually maintenance-free

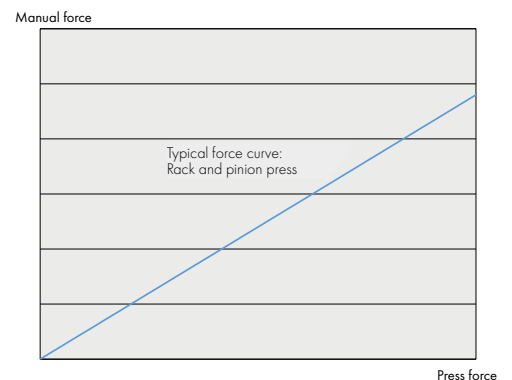
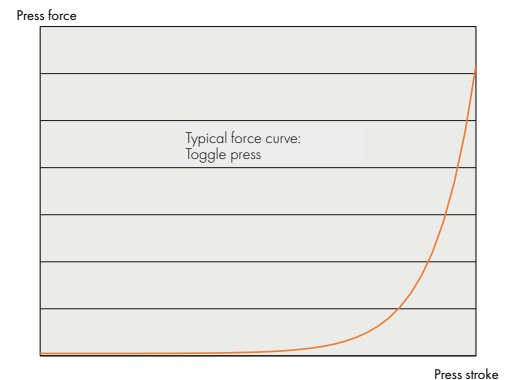

Pictograms in the catalogue show which accessories are possible for which presses.

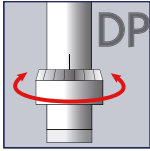

Precision ram adjustment (DP)

As toggle presses do not achieve their maximum force until BDC, adjusting the height of the press head by means of the threaded spindle is often too inaccurate. The precision ram adjustment enables the press pressure point to be precisely set directly at the ram. The scale on the adjustment ring enables the fine setting to be read off to 0.02 mm. The adjustment range is ± 1.5 mm. The precision ram adjustment is used when the utmost precision is required for the press depth. Ideal for prototype manufacture and serial production when accurate and easy adjustment within the tolerance range is required.



Micrometer stop (MICRO)

The micrometer stop is used with rack and pinion presses for high-precision assembly work or for when the tool has to be accurately positioned. This enables the press stroke length to be accurately adjusted to 0.01 mm.

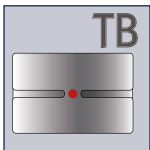
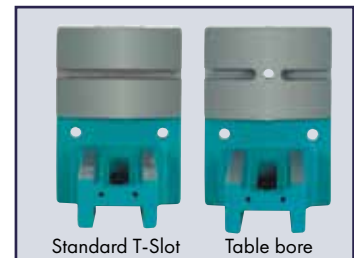

Table bore (TB)

The bottom part of the tool can be mounted in the centric table bore. Fixing is by means of a transverse screw in all models up to 80 mm throat. The table bore enables the tool to be changed quickly and reduces set-up time. The alignment accuracy of the ram bore with the table bore is <0.05 mm.



Standard T-Slot

Table bore

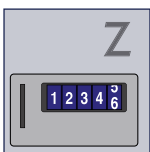

Stroke counter (Z)

A rapid overview of the number of items produced can be obtained with the five-digit stroke counter. The number of items can be reset.



Counter

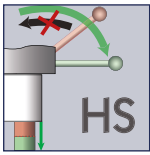

Return travel lock (HS)

The return travel lock for toggle and rack and pinion presses is an effective contribution to quality assurance during production. The return travel lock rules out partial strokes and therefore incomplete operations. Forming, assembly and joining operations are always reliably and completely executed, as the return stroke of the press is blocked on the downward stroke. The interlock is only released and the lever can only be returned when the stroke is complete. The Quick-Release mechanism enables this inhibit to be released and jammed parts to be removed in any position. The Quick-Release is automatically deactivated when the lever is returned.

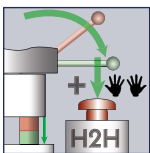
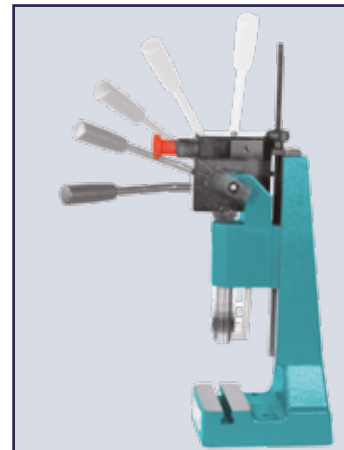

2-hand safeguard for manual toggle presses (H2H) The risk analysis for a manual toggle press workstation may indicate that using a 2-hand safeguard is advisable. This applies particularly when it is used by disabled employees or in work sequences that might induce a subconscious reaction to reach into the pressing process.

This is why mäder is now offering a 2-hand safeguard for manual toggle presses, which are generally used in mass production. The 2-hand safeguard is designed to prevent reaching into the ram movement, as both hands have to be out of the danger zone before the press can be operated. First the left hand has to actuate the 2-hand safeguard by pressing it down, before the right hand pulls down the manual press lever. If the 2-hand safeguard is actuated during the press stroke, the press blocks downward movement, but it can be reset at any time to its starting position.



Practical accessories

ERGO-hand lever for all mäder hand-operated presses.



The ERGO hand lever for mäder hand-operated presses improves their ergonomics. The horizontal and rota-table hand lever permits operation of the press without fully grasping it, and so increases the ease of use.

If your hand-operated press is to remain mobile

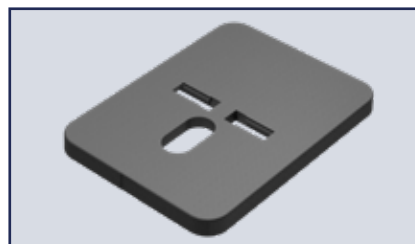

The hand-operated press fastened to a practical **baseplate** stands firm and does not tilt. Rubber stoppers prevent it from slipping. Two movable threaded inserts can be adjusted to the distance between the fixing holes of the press.

The accessories

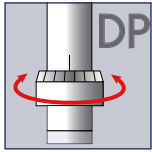

Manual toggle presses with round ram EP range

EP Type toggle presses in 5 kN, 7.5 kN and 12 kN sizes are designed for serial or individual manufacture in manual workstations. As the nominal end force is produced at the end of the stroke, a large force can be exerted at the exact point it is required. The manual force of 120 N to be applied is user-friendly. As many applications require less force, fatigue-free working is possible even with serial production.

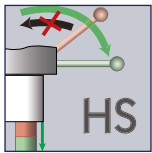

ERGOPRESS® hand lever

- ▶ Ergonomic user comfort.
- ▶ 360° stepless adjustment
- ▶ Lever angled to the side: free view of work area and ergonomically comfortable position.
- ▶ Simple and easy conversion for left-handers (except HS and Z option) without losing the tool setting. Ideal for job sharing on one press.

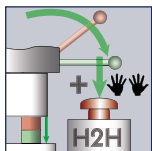
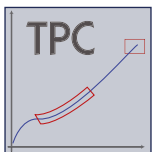
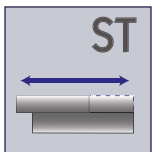
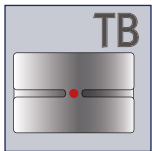
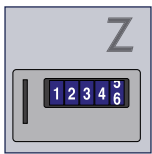

Für
EP 500-40
EP 750-40
VK 500-40
VK 750-40



Manual lever can be refitted for right and left-handers

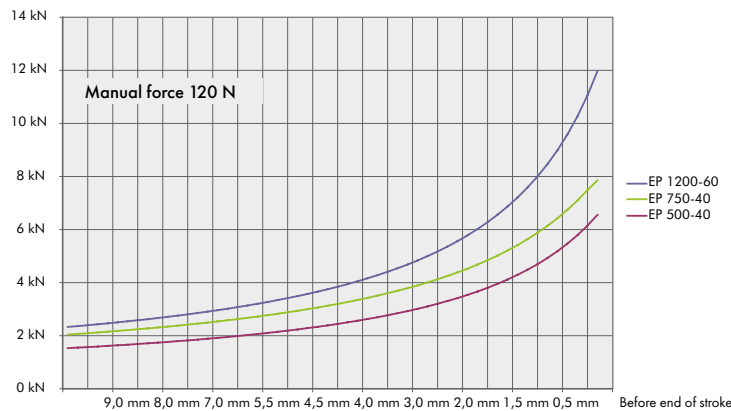

Standard

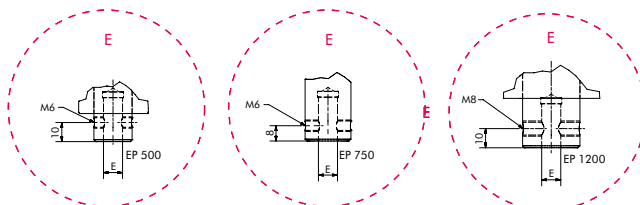

With DP

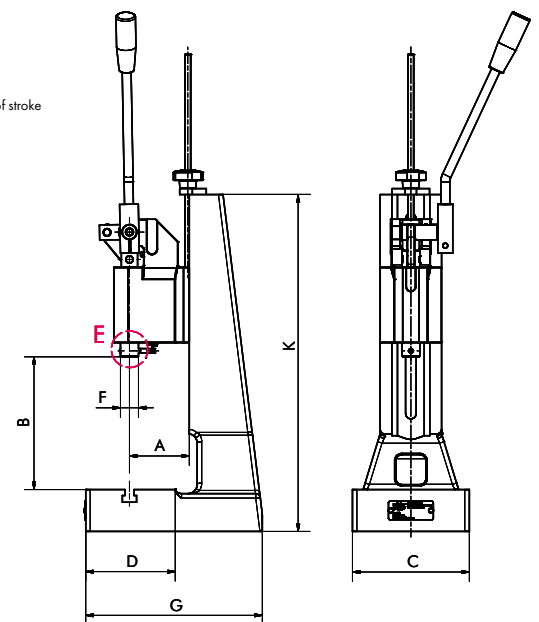
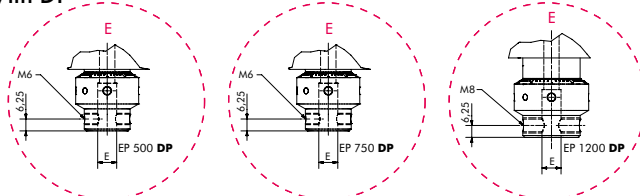

The accessories

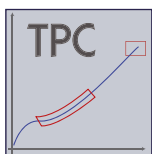
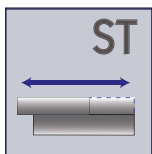
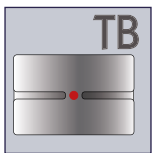
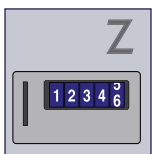
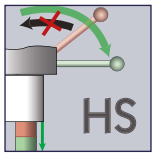
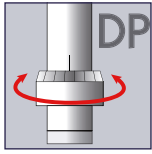

APK T range

The extra-powerful hand-operated toggle presses of the APK T 3 and APK T 4 ranges are especially suitable for the frequently changing applications in modelmaking and in the workshop. Their high forces of up to 30 kN enable them to be flexibly used for widely differing applications.

The advantages:

- ▶ Choice of different stroke lengths
- ▶ Extra-stable press base design
- ▶ Daylight easily adjustable by means of the standard press head threaded spindle height adjustment
- ▶ The nominal force of the press can be achieved with moderate applied force

XL-APK T range with 250 mm throat

A larger throat is required wherever bulky parts are processed, e.g. the processing of printed circuit boards, sheet metal and similar parts. mäder XL presses with 250 mm throat are employed in such cases. The base is a stable welded structure to which different standard press heads can be fitted.

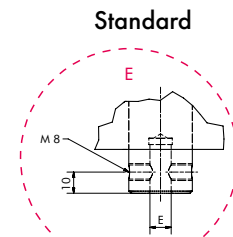
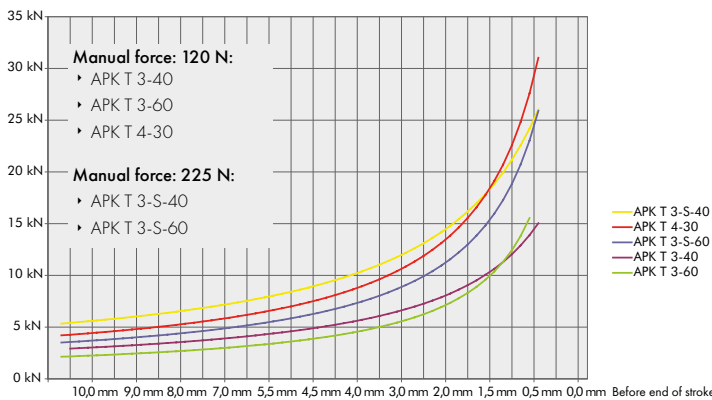

With DP

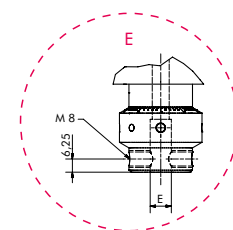

XL models

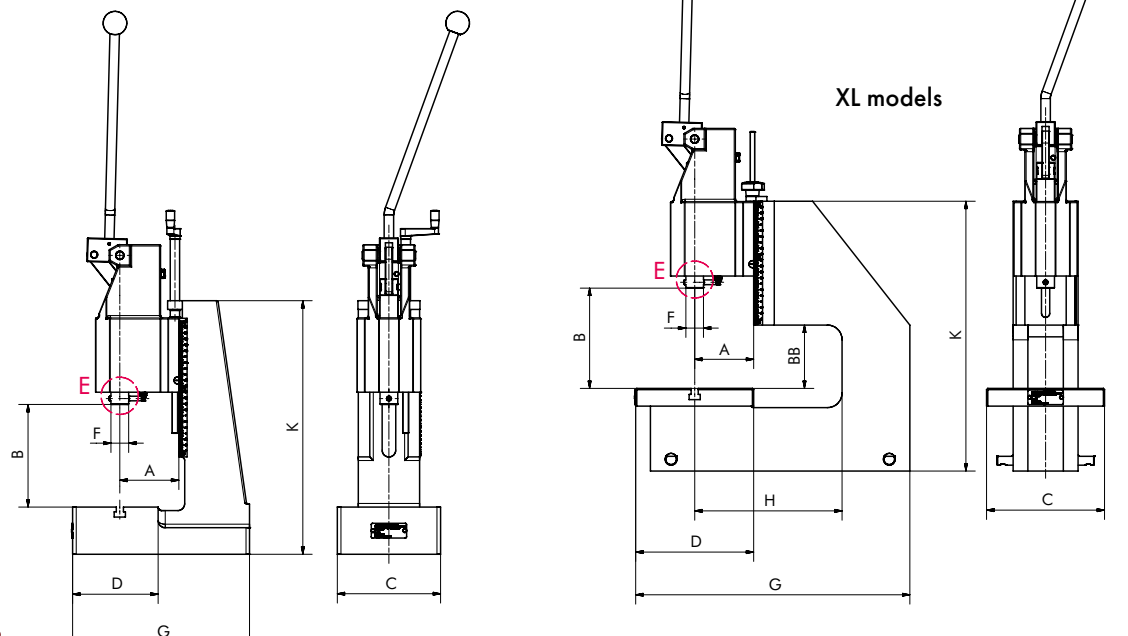

APK T range
XL-APK T range with 250 mm throat



Toggle presses

APK T 3-40
equipped with ERGO hand lever*

APK T 3-S-60

XL-APK T 3-40

Type			APK T3-40	APK T3-60	APK T3-S-40	APK T3-S-60	APK T4-30	XL-APK T3-40	XL-APK T3-60
Capacity		kN	15.0	15.0	25.0	25.0	30.0	15.0	15.0
Working stroke		mm	40	60	40	60	30	40	60
Throat	A	mm	100	100	100	100	100	100	100
Throat C-frame	H	mm	-	-	-	-	-	250	250
Daylight	B	mm	49 - 168	51 - 172	60 - 290	65 - 295	55 - 285	88 - 166	90 - 168
Daylight with DP	B	mm	35 - 154	30 - 151	46 - 274	44 - 274	34 - 264	72 - 150	69 - 147
Daylight C-frame	BB	mm	-	-	-	-	-	100	100
Table size	CxD	mm	175 x 140	175 x 140	185 x 145	185 x 145	185 x 145	200 x 200	200 x 200
T-slot width similar to DIN 650		mm	12	12	12	12	12	12	12
Ram bore Ø x Depth	E	mm	10H7 x 30	10H7 x 30	10H7 x 30	10H7 x 30	10H7 x 30	10H7 x 30	10H7 x 30
Ram bore Ø x Depth with DP			10H7 x 25	10H7 x 25	10H7 x 25	10H7 x 25	10H7 x 25	10H7 x 25	10H7 x 25
Ram Ø	F	mm	30	30	30	30	30	30	30
Space requirement	CxG	mm	175 x 300	175 x 300	185 x 320	185 x 320	185 x 320	200 x 465	200 x 465
Stand height	K	mm	425	425	520	520	520	465	465
Weight		kg	ca. 39	ca. 43	ca. 58	ca. 63	ca. 63	ca. 54	ca. 58

Accessories (see Page 8-9)	Please specify when ordering.							
Precision ram adjustment		DP	DP	DP	DP	DP	DP	DP
Return travel lock		HS	HS	HS	HS	HS	HS	HS
Counter		Z	Z	Z	Z	Z	Z	Z
Table bore 12H7		TB	TB	TB	TB	TB	TB	TB

*Not included. Accessories must be ordered separately.

Presented by: Absolute Gauge Technologies



Absolute Gauge Technologies

sales@absolute-gauge.com; www.absolute-gauge.com,
Toronto: 416 754 3168, Montreal: 514 695 5147, Toll Free: 1 888 754 7008