



8B33

Isolated True RMS Input Modules

Description

Each 8B33 True RMS input module provides a single channel of AC input which is converted to its True RMS DC value, filtered, isolated, amplified, and converted to a standard process voltage output (Figure 1).

The field voltage or current input signal is processed through a pre-amplifier and RMS converter on the field side of the isolation barrier. The converted DC signal is then chopped by a proprietary chopper circuit and transferred across the transformer isolation barrier, suppressing transmission of common mode spikes and surges. The computer side circuitry reconstructs, filters, and converts the signal to an industry standard output of 0 to 5VDC.

Special input circuits provide protection against accidental connection of power line voltages up to 350VAC and against transient events defined by ANSI/IEEE C37.90.1.

► Features

- Interfaces to RMS Voltage (0-300V) or RMS Current (0-1A)
- Designed for Standard Operation with Frequencies of 45Hz to 1000Hz (Extended Range to 10kHz)
- Compatible with Standard Current and Potential Transformers
- Industry Standard Output of 0 to 5VDC
- ±0.25% Factory Calibrated Accuracy
- 1500Vrms Transformer Isolation
- Input Overload Protected to 350Vrms Max (Peak AC & DC) or 2Arms Continuous
- 120dB CMR
- 70dB NMR at 60Hz
- ANSI/IEEE C37.90.1 Transient Protection
- C-UL-US Listed
- CE Compliant
- ATEX Compliance Pending
- Mix and Match Module Types on Backpanel

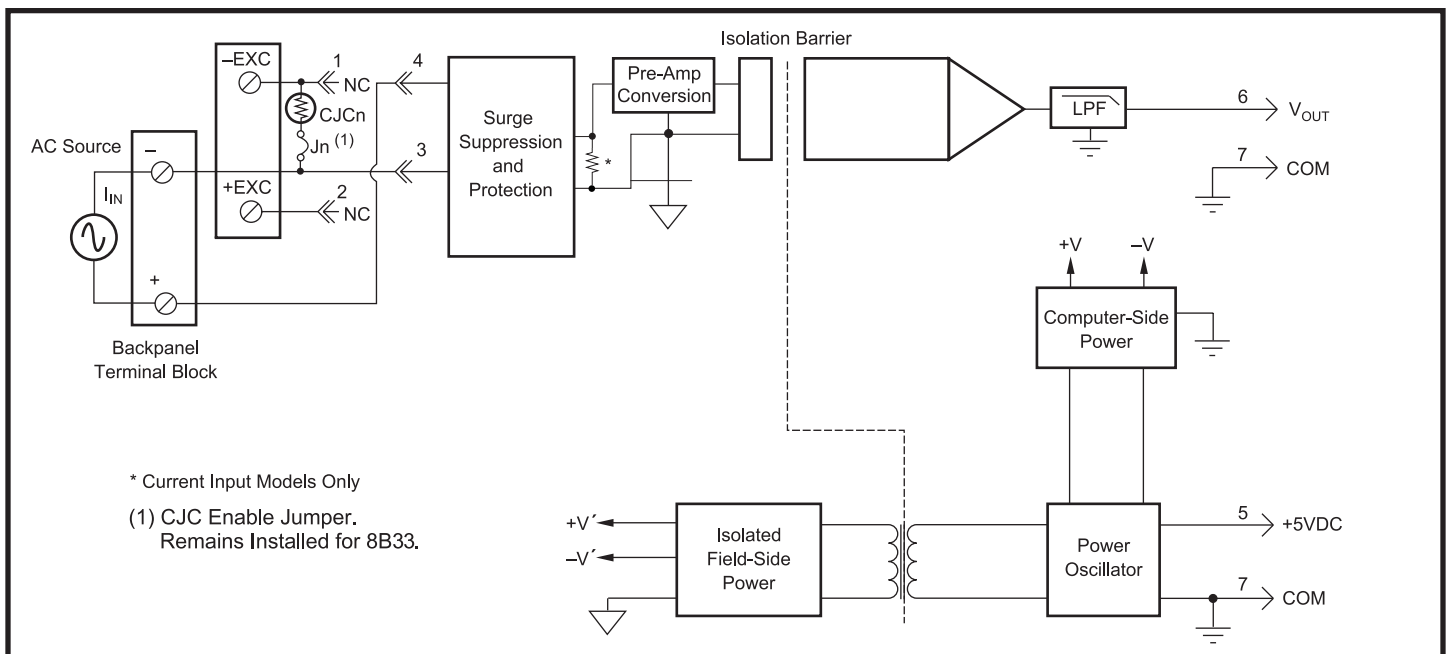

Figure 1: 8B33 Block Diagram

Specifications Typical* at T_A=+25°C and +5VDC power

Module	8B33
Input	
Signal Range	100mV to 300Vrms, 0 to 1Arms
Standard Frequency Range	45Hz to 1000Hz
Extended Frequency Range	1kHz to 10kHz
Impedance	499KΩ (-01, -02) 1MΩ (-03, -04, -05) .05Ω (-06)
Coupling	AC
Protection (1)	
Continuous (-01 thru -05)	350Vrms
Continuous (-06)	2Arms
Transient (-01 thru -05)	ANSI/IEEE C37.90.1
Transient (-06)	See note 2
Output	
Signal Range	0V to 5V
Voltage Limit	±9V
Protection	Continuous Short to Ground
Ripple and Noise	0.0375% Span rms
Accuracy (5-100% Span)^{(3) (4)}	
Sinusoid	
50/60Hz	±0.25% Span
45Hz to 1kHz	±0.625% Span
1kHz to 10kHz	±1.375% Span, ±3.25% Span(-06)
Non-Sinusoid	
Crest Factor = 1	±0.25% Span
Crest Factor = 2	±0.325% Span
Crest Factor = 3	±0.475% Span
Crest Factor = 4	±0.7% Span
Vs. Temperature	±100ppm/°C
Isolation (Common Mode)	
Input to Output, Input to Power	1500Vrms max
Continuous	ANSI/IEEE C37.90.1
Transient	
CMR (50Hz to 60Hz)	120dB
NMR	70dB at 60Hz
Response Time, 90% Span	<120mS
Supply Voltage	+5VDC ±5%
Current	30mA
Sensitivity	±200ppm/%
Mechanical Dimensions	1.11" x 1.65" x 0.40" (28.1mm x 41.9mm x 10.2mm)
Environmental	
Operating Temperature Range	-40°C to +85°C
Storage Temperature Range	-40°C to +85°C
Relative Humidity	0 to 90% Noncondensing
Emissions EN61000-6-4	ISM, Group 1
Radiated, Conducted	Class A
Immunity EN61000-6-2	ISM, Group 1
RF	Performance A ±0.5% Span Error
ESD, EFT, Surge, Voltage Dips	Performance B

NOTES:

* Contact factory or your local Dataforth sales office for maximum values.

- (1) 8B33 and 8BP01, 8BP02, 8BP04, 8BP08, 8BP16, XEV rating only. Backpanels obtained from other sources may have lower ratings.
- (2) For 1 to 25 seconds the max allowable transient current rating is $\sqrt{2500/(\text{event time})}$. For less than 1 second, ANSI/IEEE C37.90.1 applies with a 0.05 Ω load. For greater than 25 seconds, the 2 Arms continuous rating applies.
- (3) At standard 60Hz factory calibration. Consult factory for calibration at other frequencies.
- (4) For 0-5% Span measurements add 1% accuracy error (-02, -03, -04, -05) or 1.5% accuracy error (-01, -06). Accuracy error includes linearity, hysteresis and repeatability but not source or external shunt inaccuracy (if used).

Ordering Information

Model	Input Range	Output Range
8B33-01	0mV to 100mV	0V to +5V
8B33-02	0V to 1V	0V to +5V
8B33-03	0V to 10V	0V to +5V
8B33-04	0V to 150V	0V to +5V
8B33-05	0V to 300V	0V to +5V
8B33-06	0A to 1A	0V to +5V