

High Precision Pressure Transducer

**Series 8201
Version H**

Code:	8201 H EN
Delivery:	ex stock/3 weeks
Warranty:	24 months



- Measuring ranges from 0 ... 30 bar to 0 ... 500 bar
- Accuracy < 0.1 %
- Output 0 ... 5 V, 0 ... 20 mA or 4 ... 20 mA available
- Suitable for liquid and gaseous media
- Can be used for dynamic and static measurements
- Made of stainless steel, reliable and sturdy
- Standardized sensitivity to 1.0 mV/V

Application

High-precision pressure sensors from the 8201 series provide exact measurements while exhibiting very little sensitivity to mechanical stresses. Their application therefore goes well beyond research and development laboratories. They are also outstandingly suited to industrial use in quality assurance or for measurement and control tasks in production. Their robust mechanical and electrical construction guarantees good long-term stability and high reliability, while being resistant to aggressive media – which can be measured in liquid or gaseous states.

The structure of the sensors includes no mechanical moving parts, which is why they show so little sensitivity to impact and vibration.

The pressure sensors can be configured with options to suit the user. Standard types are available ex-stock, and customized customer versions can also be provided.

Areas of application are:

- ▶ Research and development
- ▶ Test rigs
- ▶ Mechanical engineering
- ▶ Plant control and monitoring

Description

The medium reaches the interior of the measuring chamber through the pressure port. This is closed by a membrane which is welded on, and which represents the sensor element itself. The bending of this membrane increases in proportion to the applied pressure. Four strain gauges, interconnected as a Wheatstone bridge, are attached at the rear. The physical magnitude of pressure is converted by the wire strain gauges into a change in electrical resistance. The resulting output signal is standardized to 1.0 mV/V.

The pressure is measured relative to the surrounding air pressure, and the space behind the membrane is therefore connected to the atmosphere through a small, protected opening in the housing.

All the sensors can be supplied with an integrated amplifier having a voltage or current output. The input to the integrated amplifier is protected against reverse polarity connection, and the output is protected against overvoltage.

Technical Data

Order Code (see Order Code)	Measuring Range	Resonance Frequency [kHz]
8201-5030-xxxxx	0 ... 30 bar	5.0
8201-5050-xxxxx	0 ... 50 bar	7.0
8201-5100-xxxxx	0 ... 100 bar	10.0
8201-5200-xxxxx	0 ... 200 bar	12.5
8201-5300-xxxxx	0 ... 300 bar	15.0
8201-5500-xxxxx	0 ... 500 bar	20.0

Electrical values

Bridge resistance: full bridge circuit of foil strain gauge 350 Ω, nominal
 Calibration resistor: 100 kΩ
 The bridge output voltage resulting from a shunt of this value is shown in the test certificate.
 Excitation voltage: recommended 5 V DC maximum 10 V DC
 Nominal sensitivity: standardized; 1.0 mV/V ± 0.25 %

Environmental conditions

Range of operating temperature: - 30 °C ... 120 °C
 Nominal temperature range: 0 °C ... 70 °C
 Influence of temperature on zero: ≤ ± 0.005 % F.S./K
 Influence of temperature on sensitivity: ≤ ± 0.005 % F.S./K

Mechanical values

Measurement accuracy: Combined error consisting of non-linearity, hysteresis and variation: < ± 0.1 % F.S., as specified at BFSL
 Kind of measurement: measurement against atmosphere (relatively)
 Dead volume: 5.8 cm³
 Volume change: negligibly small
 Overload: measuring range ≤ 300 bar 50 % over capacity
 measuring range ≥ 500 bar 25 % over capacity
 Burst pressure: >100 % over capacity
 Dynamic performance: recommended 50 % of capacity maximum 70 % of capacity
 Design: Diaphragm pressure transducer with hermetically sealed measuring chamber (without internal sealing elements).

Material: stainless steel, 1.4548.9
 Pressure port: internal thread M 16 x 1.5
 Sealing: Support ring and O-ring, is included in scope of delivery
 Mounting torque: max. 3 Nm
 Electrical connection: 6 pin bayonet model connector Souriau 851 07A 10 - 6 P
 Wiring code: pins A + B excitation voltage positive
 pins C + D excitation voltage negative
 pins E signal output negative
 pins F signal output positive
 Dimensions: refer to dimensional drawing
 Weight: approx. 420 g ... 650 g
 Protection class acc. to EN 60529: IP65
 Mating plug: model 9945
 Amphenol 62-GB-16F-10-6S or Souriau 851-06E-C-10-6S

Technical Data of the Internal Amplifier

	Voltage output	Current output
Excitation voltage	15 ... 30 V DC	
Current consumption	max. 40 mA	max. 65 mA
Connection technology	3 wire	
Load impedance	-	< 200 Ω + 40 Ω/V (U _{Ref} -15 V DC)
Nominal temperature range	0 °C ... 60 °C	
Range of operating temperature	0 °C ... 60 °C	
Cut-off frequency	(- 3 dB) 1 kHz	
Protection against short-circuit and polarity	yes	
Zero offset and span setting	± 0.25 % F.S.	

Wiring Code

Pin	without Amplifier	Voltage output	Current output
A	excitation +	excitation +	excitation +
B		signal - and excitation -	signal - and excitation -
C	excitation -	signal +	signal +
D		NC	NC
E	signal -	NC	NC
F	signal +	NC	NC

Dimensional drawing model 8201 H

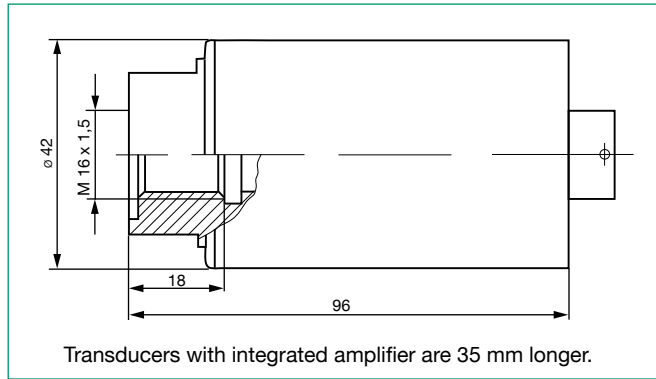

The CAD drawing (3D/2D) for this sensor can be imported online directly into your CAD system.

Download via www.burster.com or directly at www.traceparts.com. For further information about the burster traceparts cooperation refer to data sheet 80-CAD-EN.

Accessories

- Thread adapter, material 1.4571, for following connecting threads
- External thread M 16 x 1.5 **Model 8281**
- External thread G 1/2" A **Model 8283**
- External thread R 1/4" (max. 500 bar) **Model 8285**
- External thread M 20 x 1.5 **Model 8286**
- External thread 3/4 - 16 UNF **Model 82822**
- External thread M 14 x 1.5 **Model 82825**
- Internal thread 3/4 - 16 UNF **Model 82827**
- Internal thread 1/4 - 18 NPT (max. 500 bar) **Model 82829**
- Standard sealing ring set (included in scope of delivery) **Model 82911**
- TFE sealing ring set for critical applications;
- Teflon-coated Viton® thrust and O-ring **Model 82910**
- Mating plug (included in scope of delivery) **Model 9945**

Test and Calibration Certificate

Included in delivery, et al. with specification of zero output, sensitivity and shunt calibration factor.

Connecting Cables

for transducers plug-in connection and bridge output, completely with connector and socket, 6 wire, shielded PVC isolated cable, bending radius > 5 mm, standard length of 3 m.
 to burster desktop indicators with 12 pin connection **Model 9911**
 to SENSORMASTER 9163 **Model 99209-545D-0160030**
 with open, color coded and tinned cable ends **Model 9986**
 for transducers with internal amplifier; with open, color coded and tinned cable ends **Model 99545-000D-0160030**
 Other cable lengths or customized cables on request.

Order Code

High precision pressure transducer	8201-XXXX-H	1A
without amplifier	02	
integrated amplifier with voltage output 0 ... 5 V	33	
integrated amplifier with current output 0 ... 20 mA	37	
integrated amplifier with current output 4 ... 20 mA	39	

Order Information

High precision pressure transducer, measuring range 0 ... 200 bar, integrated amplifier for 0 ... 5 V **8201-5200-H331A**

DAkS Calibration Certificate

According to standard DKD-R 6-1 with 21 measuring points in 10 % increments for rising and falling pressure. **Order Code 82DKD-XX**

Factory Calibration Certificate (WKS)

Calibration of a pressure transducer separately as well as connected to an indicator. Standard is a certificate with 11 points, starting at zero, running up and down in 20% increments and covering the complete measuring range. Special calibrations on request. Calculation of costs by base price plus additional costs per point.

Order Code 82WKS-82XX